

(12) STANDARD PATENT
(19) AUSTRALIAN PATENT OFFICE

(11) Application No. **AU 2006285501 B2**

(54) Title
Cell for testing fluids at elevated pressures

(51) International Patent Classification(s)
G01N 1/10 (2006.01) **G01N 33/28** (2006.01)

(21) Application No: **2006285501** (22) Date of Filing: **2006.08.31**

(87) WIPO No: **WO07/027099**

(30) Priority Data

(31) Number	(32) Date	(33) Country
60/712,419	2005.08.31	US

(43) Publication Date: **2007.03.08**

(44) Accepted Journal Date: **2011.11.10**

(71) Applicant(s)
Sinvent AS

(72) Inventor(s)
Lindeberg, Erik Gosta Bruno

(74) Agent / Attorney
Davies Collison Cave, 1 Nicholson Street, Melbourne, VIC, 3000

(56) Related Art
WO 2002/001211 A1
GB 2346669 A
US 5126058 A
EP 0180844 A1

(12) INTERNATIONAL APPLICATION PUBLISHED UNDER THE PATENT COOPERATION TREATY (PCT)

(19) World Intellectual Property Organization
International Bureau



(43) International Publication Date
8 March 2007 (08.03.2007)

PCT

(10) International Publication Number
WO 2007/027099 A1

- (51) International Patent Classification:
G01N 1/10 (2006.01) G01N 33/28 (2006.01)
- (21) International Application Number:
PCT/NO2006/000307
- (22) International Filing Date: 31 August 2006 (31.08.2006)
- (25) Filing Language: English
- (26) Publication Language: English
- (30) Priority Data:
60/712,419 31 August 2005 (31.08.2005) US
- (71) Applicant (for all designated States except US): SIN-
VENT AS [NO/NO]; S P Andersens Vei 5, N-7465
Trondheim (NO).
- (72) Inventor; and
- (75) Inventor/Applicant (for US only): LINDEBERG, Erik,
Gøsta, Bruno [NO/NO]; Klostergata 62, N-7030 Trond-
heim (NO).
- (74) Agent: BRYN AARFLOT AS; P.O. Box 449 Sentrum,
N-0104 Oslo (NO).
- (81) Designated States (unless otherwise indicated, for every
kind of national protection available): AE, AG, AL, AM,
AT, AU, AZ, BA, BB, BG, BR, BW, BY, BZ, CA, CH, CN,
CO, CR, CU, CZ, DE, DK, DM, DZ, EC, EE, EG, ES, FI,
GB, GD, GE, GH, GM, HN, HR, HU, ID, IL, IN, IS, JP,
KE, KG, KM, KN, KP, KR, KZ, LA, LC, LK, LR, LS, LT,
LU, LV, LY, MA, MD, MG, MK, MN, MW, MX, MY, MZ,
NA, NG, NI, NO, NZ, OM, PG, PH, PL, PT, RO, RS, RU,
SC, SD, SE, SG, SK, SI, SM, SV, SY, TJ, TM, TN, TR,
TT, TZ, UA, UG, US, UZ, VC, VN, ZA, ZM, ZW.
- (84) Designated States (unless otherwise indicated, for every
kind of regional protection available): ARIPO (BW, GH,
GM, KE, LS, MW, MZ, NA, SD, SL, SZ, TZ, UG, ZM,
ZW), Eurasian (AM, AZ, BY, KG, KZ, MD, RU, TJ, TM),
European (AT, BE, BG, CH, CY, CZ, DE, DK, EE, ES, FI,
FR, GB, GR, HU, IE, IS, IT, LT, LU, LV, MC, NL, PL, PT,
RO, SE, SI, SK, TR), OAPI (BF, BJ, CF, CG, CI, CM, GA,
GN, GQ, GW, ML, MR, NE, SN, TD, TG).
- Published:
— with international search report

[Continued on next page]

(54) Title: CELL FOR TESTING FLUIDS AT ELEVATED PRESSURES

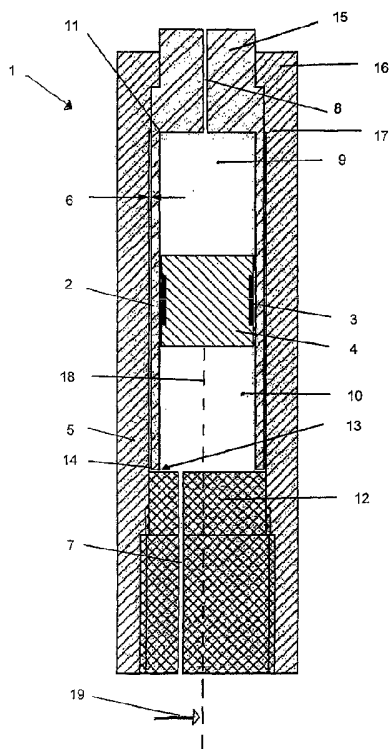

(57) Abstract: An apparatus for a burst safe pressure-neutral high pressure cylinder in pVT and condensate cells is described. The dimensions of an outer cylinder are such as to prevent plastic flow of the inner cylinder wall caused by elevated inside pressure and/or temperature.

WO 2007/027099 A1

WO 2007/027099 A1



For two-letter codes and other abbreviations, refer to the "Guidance Notes on Codes and Abbreviations" appearing at the beginning of each regular issue of the PCT Gazette.

2006285501 19 Oct 2011

- 1 -

CELL FOR TESTING FLUIDS AT ELEVATED PRESSURES

The present invention relates to a test cell for testing fluids at elevated pressures.

5 A test cell embodying the present invention comprises a pressure-neutral cylinder for use in pressure, volume and temperature (pVT) studies of reservoir fluids and their properties in the laboratory and in the field.

10 In pVT cells and condensate cells, petroleum fluids can be studied at varying pressure and temperature simulating the conditions in oil reservoirs before and during production. Typically, these fluids contain gas. The change in fluid density (compressibility) and the tendency for the gas to come out of solution at decreasing pressure, are of particular interest.

15 pVT cells are optimised to study oils with dissolved gas, while condensate cells are optimised to study light oils with a high gas to oil ratio. In the following, they are both denoted pVT cells.

20 Until the late eighties, the method for controlling the pressure in these pVT cells was to pump mercury in and out of the cell, mercury being considered as inert with respect to the petroleum fluids.

25 There were however some health risks involved in the handling of mercury at high pressure and temperature, and this method has to a large extent been replaced by other methods for changing the volume in pVT cells. Several of the new designs are based on cylindrical cells with a sealed piston that can be moved by either direct mechanical drive or hydraulic drive.

A problem with the piston solution is that the diameter of the cell will change with pressure, and thus the clearance between piston and wall will change, which makes rather high demands on the seals.

In order to solve the problem of varying clearance with pressure, a relatively thin inner cylinder, which is in contact with a dynamic seal on the piston and with the fluids, is enclosed in a thick-walled high pressure cylinder. The space between the cylinders is filled with hydraulic fluid, and is connected to the same line that provides such fluid under high pressure to hydraulically control the piston position. Thus it is ensured that the (differential) pressure across the inner cylinder is negligible.

This solution gives the following advantages:

1. The material of the inner cylinder can be selected independently to meet various specifications. The material of the inner cylinder can be selected to be chemically compatible with the fluids (e.g. Hastelloy C, glass, Inconel) while the outer cylinder needs only to be strong enough to meet pressure specification (e.g. high strength steel) or a combination of weight and strength specifications (e.g. Ti-6Al-4V).
2. The diameter of the inner tube does not change with pressure, and the volume of the test fluid chamber is therefore only dependent on the position of the piston which can be monitored directly.

This solution is applied in the so-called "DBR Jefri" cells with utilisation of a pressure-neutral inner cylinder made of a glass material, and with external connection for the pressure outside the inner cylinder and the pressure behind the piston.

If the piston position accidentally is at the bottom of the cylinder, a pressure difference across the inner cylinder wall may occur due to elevated pressure in the inside test fluid (caused by temperature increase or charging with more test fluid), or by a falling pressure in the hydraulic system. This pressure difference might burst or cause plastic flow of the inner cylinder wall, depending on the cylinder material being brittle or ductile.

2006285501 19 Oct 2011

- 3 -

While the DBR solution provides a pressure-neutral inner cylinder and chemical compatibility with test fluids, both material deformation properties and clearances are such as to allow the inner cylinder to deform and/or break.

5 Hence, an alternative apparatus from those described above is needed to perform pVT studies without the risk and inconvenience of bursting or deforming the inner cylinder.

The invention provides a test cell for testing fluids at elevated pressures,
10 comprising:

an inner cylinder inside which a piston is movable axially by hydraulic means to control pressure and volume of a fluid contained at a test fluid side of the piston, said inner cylinder having a thin cylinder wall and being closed at an end at said test fluid side; and

15 an outer cylinder coaxially arranged outside said inner cylinder, thereby forming an annular space between said cylinders, said outer cylinder having a thick and sturdy construction, and at least one port for introducing hydraulic fluid to a hydraulic side of said piston opposite said test fluid side, and to said annular space,

wherein said annular space has a radial dimension less than a maximum elastic expansion range of said inner cylinder, whereby rupture of said inner cylinder from a high
20 differential pressure across the cylinder wall can be avoided, due to restriction by said outer cylinder.

Preferred embodiments of the present invention provide an improved pVT cell.

25 In order to provide a favourable and effective mounting procedure, as well as a simple layout for the hydraulic port arrangement for a test cell in accordance with the invention, the following preferable embodiment of the invention is provided: the outer cylinder is closed by a sealing plug having an axial clearance to an open end of the inner cylinder, thereby providing fluid communication between the hydraulic side inside the
30 inner cylinder and the annular space. Hence, only one port for hydraulic fluid is necessary.

- 4 -

Further, in order to provide simple and effective means for measuring the test fluid volume, there is in another preferable embodiment provided an axially arranged piston rod attached to the piston and extending out of the cell through a sealed opening in an end closure, and past a measurement device for piston position.

5

In the following, a more detailed explanation of the invention will be given, by way of non-limiting example only, with reference to fig. 1 , which shows a cross-section through a schematic (idealized) embodiment of a pVT cell in accordance with the present invention.

10

In fig. 1 appears a pVT cell 1 in accordance with an embodiment of the present invention. A relatively thin inner cylinder 2 which is in contact with a dynamic seal 3 on a piston 4 and with a fluid 9 to be tested as well as a hydraulic fluid 10, is enclosed by a thick-walled high pressure cylinder 5. An annular space 6 between cylinders 2 and 5 is filled with hydraulic fluid, by connection to the same line 7 that controls the piston position. High pressure fluids 9 that are subjected to study are fed through a high pressure port 8 at the top of the cell 1.

The gap 6 between the inner and outer cylinders 2, 5 is so small that it is less than the limit for elastic deformation of the inner cylinder 2, so that the inner cylinder, on sudden expansion, will rest on the outer cylinder 5 before being damaged. The cell is therefore robust, and will not be damaged by deformation caused by inner pressure, even if the outer pressure drops significantly.

The reason for expansion of the inner cylinder 2, may be an inside overpressure, contained fluid elevated temperature or elevated temperature of

25

2006285501 19 Oct 2011

fluid and/or surrounding outer cylinder material transferring heat to increase the temperature of the inner cylinder wall.

With further reference to fig. 1, it appears that the test cell embodiment provides a burst-safe and pressure-neutral pVT cell with a cylindrical design.

5 Innermost there is a slideable piston 4 that divides the inner cylinder space into an upper compartment for receiving high-pressure test fluid 9 therein, and a lower compartment for receiving hydraulic fluid 10 therein. The piston 4 can move inside a relatively thin-walled fluid container 2 that has a substantially uniform inside diameter and concentrically an equally uniform outside diameter. At the top end, 10 this inner cylinder 2 is closed at a position 11 by an end closure 15 that is preferably integral with the thin-walled cylinder 2. There is a fluid port 8 through the end closure 15 for letting test fluid in and out of the test chamber above piston 4. When port 8 is closed, the volume and pressure of a fluid inside the top chamber is determined by the position of piston 4.

15 An outer cylinder 5 surrounds the thin-walled inner cylinder 2. The outer cylinder needs not necessarily have an outer shape that is cylindrical, but the inside shape must be a cylinder coaxial with the inner cylinder and with an inside diameter only somewhat larger than the outside diameter of the inner cylinder. Hence, what is essential is that there is a substantially uniform and coaxial 20 circumferential clearance 6 between the two cylinders. This clearance 6 has the shape of an annular channel. This annular channel extends all the way along the length of the inner cylinder. In the embodiment shown, the outer cylinder 5 is provided with a small shoulder at the position indicated by reference numeral 17. Above that position, the outer cylinder 5 is joined tightly to the end closure 15 of 25 the inner cylinder 2.

It is important that the radial dimension of the annular channel 6 is less than the elastic range of deformation of the inner cylinder 2. If the inner cylinder 2 is exposed to an overpressure from the inside, compared to the outside pressure, the wall of the inner cylinder 2 will tend to expand. The inner wall of the outer 30 cylinder 5 will then restrict further expansion of the inner cylinder and save it from rupture.

In order to provide the same hydraulic pressure to fluid 10 both in the annular channel 6 and in the hydraulic pressure chamber underneath piston 4, it is possible to provide fluid communication between these two spaces such as indicated in the embodiment shown in fig. 1, namely by providing a small axial clearance 13 between the lower end of inner cylinder 2 and a sealing plug 12 just therebelow. The sealing plug 12 is a tightening member entered from below and fastened inside the outer cylinder 5.

In this embodiment, it is only necessary with one port 7 for hydraulic fluid from a hydraulic pressure source (not shown), because the hydraulic fluid will enter the annular space 6 from the lower part of the cylinder interior.

However, in another embodiment, a closure element at the lower end of the cylinder interior may be attached to the inner cylinder 2 itself, or there may be no clearance between a sealing plug like plug 12 and the inner cylinder 2. In such a case, at least one further port for hydraulic fluid must be provided through outer cylinder 5 to the annular channel 6.

In principle, one might consider a further embodiment in which the end closure part 15 of the inner cylinder would be integrated with the outer cylinder 5 at area 16, so that the inner and outer cylinders would actually be in one piece, i.e. with the annular space 6 machined out from one "start cylinder" piece. However, such an operation is rather difficult, so the preferred embodiment is to have a separate inner cylinder 2 such as shown in the drawing, joined tightly together with the outer cylinder at top end 15, 16 by a thread connection. It appears that in a mounting operation, one would then preferably screw together the outer cylinder 5 and the inner cylinder 2 in the top area (15, 16, 17), and thereafter piston 4 would be entered into the inner space from below. Finally, an end plug 12 might be screwed tightly into the lower end of the outer cylinder. At the top end 16 of the outer cylinder, there is a shoulder inside for defining a stop for the first part of the mounting operation. Another shoulder at reference numeral 17 provides the axial dimension of the important annular channel 6.

Fig. 1 also shows an indication regarding a measurement apparatus for determining the position of the piston 4, and hence the volume of test fluid 9 in the top chamber. A dotted line represents a piston rod 18 attached to the underside of

2006285501 19 Oct 2011

- 7 -

piston 4 and extending all the way out through the sealing plug 12. Hence, there is of course a thin through channel in plug 12, with seals so as to avoid leakage therethrough. The piston rod is sufficiently long to extend to a marker or reading device 19 even when the piston 4 is in a top position. The reading device 19 cooperates with markings on the
5 piston rod 18 to establish piston position.

As regards materials, the material of the inner cylinder 2 would be selected not so much for strength, as for being chemically compatible with the fluids. Hence the previously mentioned materials Hastelloy C, glass or Inconel are candidate materials. The
10 outer cylinder needs only be sufficiently strong to meet pressure specifications, e.g. high strength steel, or specifications regarding a combination of strength and weight, for instance Ti-6Al-4V.

In a practical example, the length dimension of a pVT cell such as appearing in fig.
15 1, would be approximately 500 mm, the outer diameter would be variable within wide limits (as previously mentioned, the outer shape needs not even be cylindrical), but the outer diameter of the inner cylinder 2 might be approximately 50 mm while the wall of the inner cylinder 2 would be about 2 mm. The radial dimension of the annular channel 6 may typically be in the range 0.05 mm - 1.0 mm. A typical axial dimension of the inner
20 cylindrical space would be 200 mm, and the axial dimension of the piston 4 might be approximately 50 mm.

Neither the materials given as examples here, nor the dimensions given, should be construed as limitative regarding the scope of the present invention.
25

While various embodiments of the present invention have been described above, it should be understood that they have been presented by way of example only, and not by way of limitation. It will be apparent to a person skilled in the relevant art that various changes in form and detail can be made therein without departing from the spirit and scope
30 of the invention. Thus, the present invention should not be limited by any of the above described exemplary embodiments.

2006285501 19 Oct 2011

- 8 -

Throughout this specification and the claims which follow, unless the context requires otherwise, the word "comprise", and variations such as "comprises" and "comprising", will be understood to imply the inclusion of a stated integer or step or group of integers or steps but not the exclusion of any other integer or step or group of integers or steps.

The reference in this specification to any prior publication (or information derived from it), or to any matter which is known, is not, and should not be taken as an acknowledgment or admission or any form of suggestion that that prior publication (or information derived from it) or known matter forms part of the common general knowledge in the field of endeavour to which this specification relates.

2006285501 19 Oct 2011

- 9 -

CLAIMS

1. A test cell for testing fluids at elevated pressures, comprising:
an inner cylinder inside which a piston is movable axially by hydraulic means to
5 control pressure and volume of a fluid contained at a test fluid side of the piston, said inner
cylinder having a thin cylinder wall and being closed at an end at said test fluid side; and
an outer cylinder coaxially arranged outside said inner cylinder, thereby forming an
annular space between said cylinders, said outer cylinder having a thick and sturdy
construction, and at least one port for introducing hydraulic fluid to a hydraulic side of said
10 piston opposite said test fluid side, and to said annular space,
wherein said annular space has a radial dimension less than a maximum elastic
expansion range of said inner cylinder, whereby rupture of said inner cylinder from a high
differential pressure across the cylinder wall can be avoided, due to restriction by said
outer cylinder.
15
2. The test cell of claim 1, wherein said outer cylinder is closed by a sealing plug
having an axial clearance to an open end of said inner cylinder, thereby providing fluid
communication between said hydraulic side inside said inner cylinder and said annular
space.
20
3. The test cell of claim 1 or 2, further comprising an axially arranged piston rod
attached to said piston and extending out of said cell through a sealed opening in an end
closure, and past a device for measuring piston position.
- 25 4. A test cell substantially as hereinbefore described with reference to the drawings
and/or Examples.

1/1

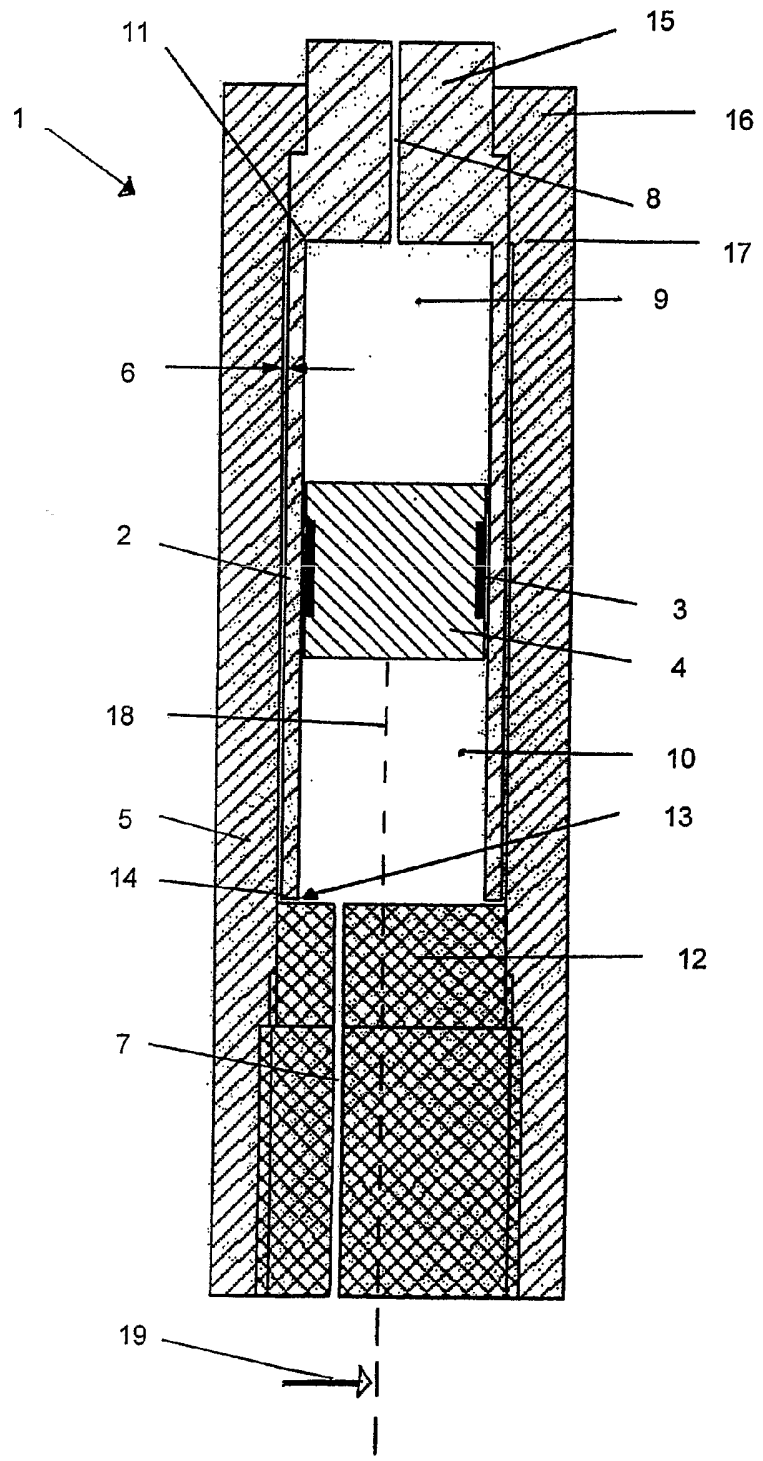

FIG. 1