



US007896761B2

(12) **United States Patent**
Tucker, Sr. et al.

(10) **Patent No.:** **US 7,896,761 B2**
(45) **Date of Patent:** ***Mar. 1, 2011**

(54) **LACROSSE HEAD HAVING A FLEXIBLE STRINGING MEMBER AND A RECESSED SCOOP**

(75) Inventors: **Richard B. C. Tucker, Sr.**, Ruxton, MD (US); **Joel F. Price**, Chevy Chase, MD (US)

(73) Assignee: **WM. T. Burnett IP, LLC**, Baltimore, MD (US)

(*) Notice: Subject to any disclaimer, the term of this patent is extended or adjusted under 35 U.S.C. 154(b) by 3 days.

This patent is subject to a terminal disclaimer.

4,034,984 A	7/1977	Crawford et al.	
D248,679 S *	7/1978	Rule	D21/724
4,153,251 A	5/1979	Pond	
4,657,260 A *	4/1987	Brine, Jr.	473/513
4,938,480 A	7/1990	Lods	
5,037,112 A	8/1991	Brine, III et al.	
5,566,947 A	10/1996	Tucker et al.	
5,938,550 A	8/1999	Hexemer et al.	
6,213,901 B1	4/2001	Collinson	
6,447,410 B2	9/2002	Crawford	
6,506,132 B1	1/2003	Brine, III et al.	
6,520,875 B1	2/2003	Crawford	
6,676,547 B1	1/2004	Morrow et al.	
6,852,047 B2	2/2005	Tucker, Sr.	

(21) Appl. No.: **12/426,559**

(22) Filed: **Apr. 20, 2009**

(65) **Prior Publication Data**

US 2009/0203474 A1 Aug. 13, 2009

Related U.S. Application Data

(63) Continuation of application No. 11/345,321, filed on Feb. 2, 2006, now Pat. No. 7,520,828.

(51) **Int. Cl.**

A63B 59/02 (2006.01)

A63B 65/12 (2006.01)

(52) **U.S. Cl.** **473/513; D21/724**

(58) **Field of Classification Search** **473/505, 473/512, 513; D21/724**

See application file for complete search history.

(56) **References Cited**

U.S. PATENT DOCUMENTS

534,996 A *	3/1895	Cundy	473/511
2,075,372 A	3/1937	Taylor	
2,710,753 A	6/1955	Lockwood	
3,507,495 A	4/1970	Tucker et al.	

(Continued)

Primary Examiner—Gene Kim

Assistant Examiner—M Chambers

(74) *Attorney, Agent, or Firm*—Paul, Hastings, Janofsky & Walker LLP

(57) **ABSTRACT**

A lacrosse head having at least one of a flexible stringing member and a recessed scoop is provided. In one embodiment, a slot is formed in a head along a stop member, a sidewall, and/or a scoop to provide the flexible stringing member. In another embodiment, the flexible stringing member is a flexible stringing bar that extends from a stop member to a scoop. In another embodiment, the flexible stringing member is more flexible in one direction than another. Through these embodiments, a flexible stringing member can dampen and dynamically narrow the pocket, enhance ball retention, increase pass/shot accuracy, and satisfy pocket-forming preferences. In another embodiment, a scoop has a recess that curves toward a stop member to increase the amount of surface area that contacts a ball when scooping.

11 Claims, 18 Drawing Sheets

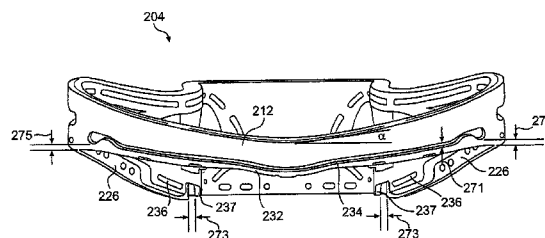
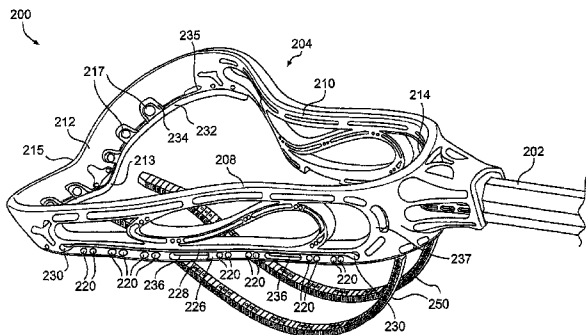

US 7,896,761 B2

Page 2

U.S. PATENT DOCUMENTS						
			2002/0160865	A1 *	10/2002	Brine et al. 473/513
6,916,259	B2	7/2005	Kohler et al.			
6,929,572	B2 *	8/2005	Morrow et al.			473/513
7,520,828	B2 *	4/2009	Tucker et al.			473/513
						* cited by examiner

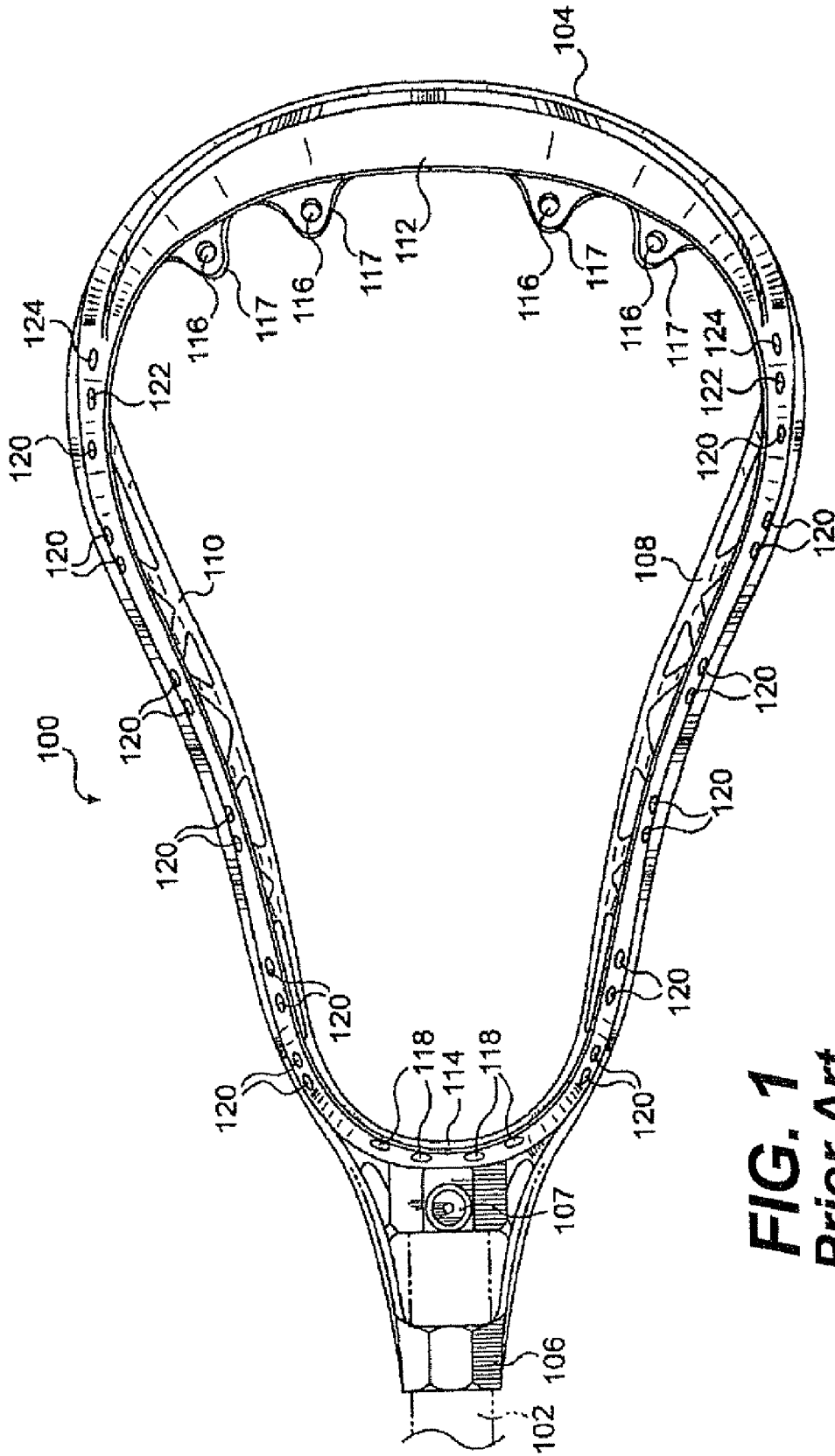

FIG. 1
Prior Art

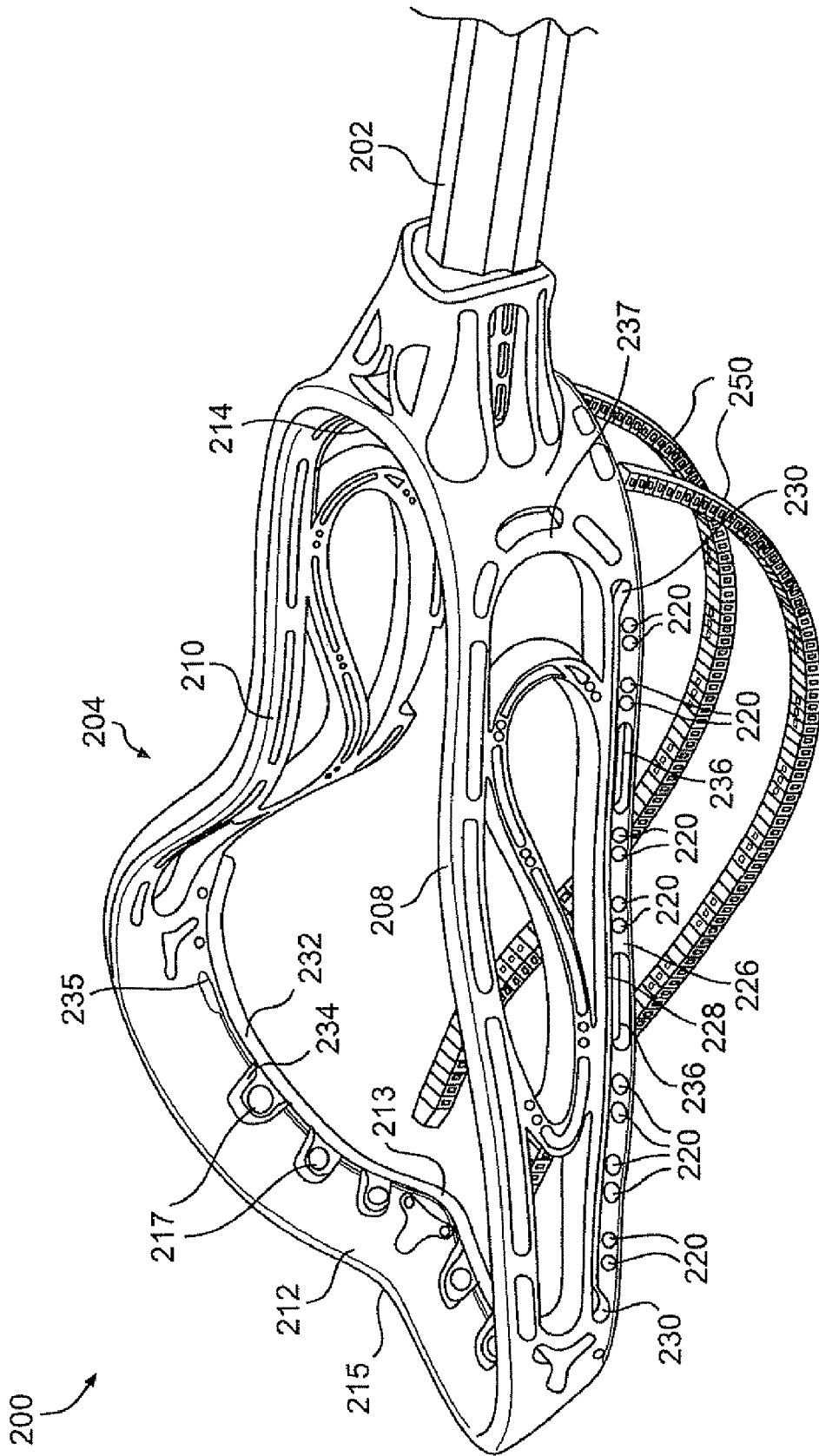

FIG. 2

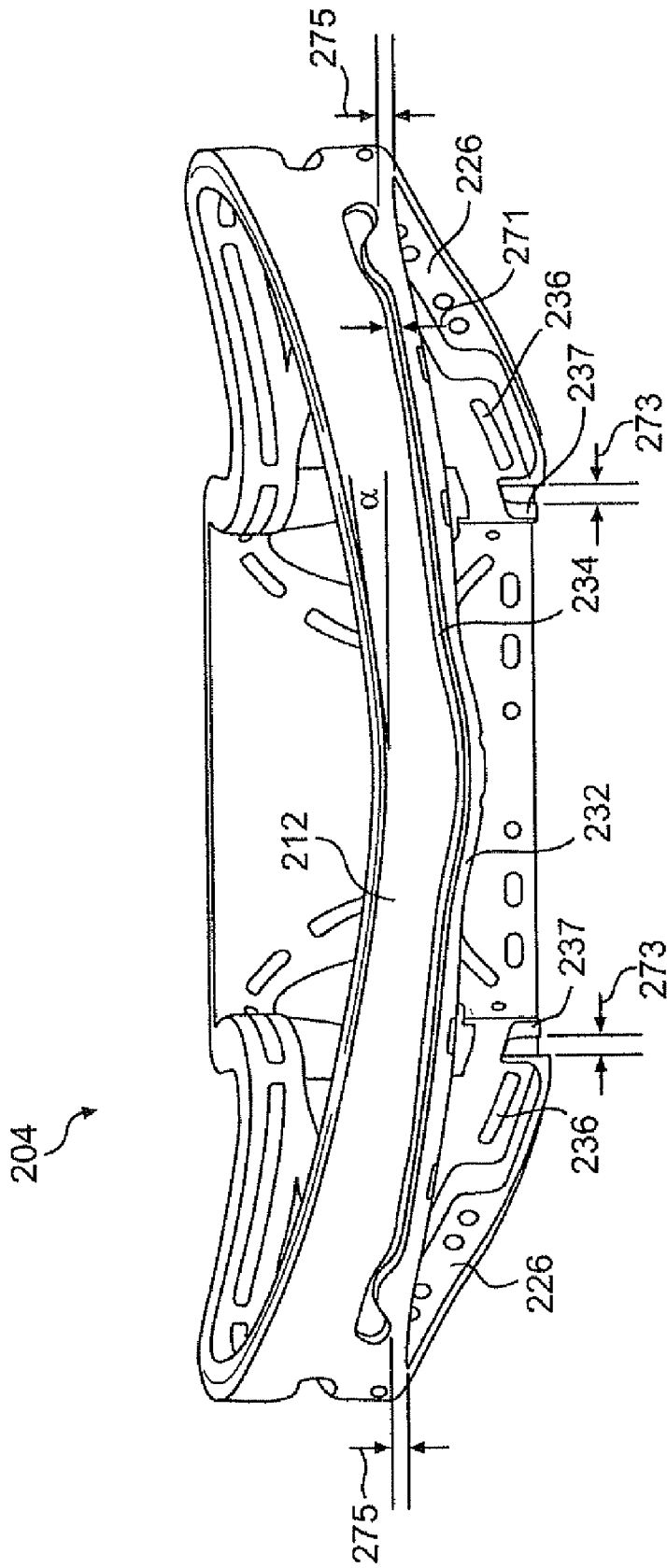

FIG. 3

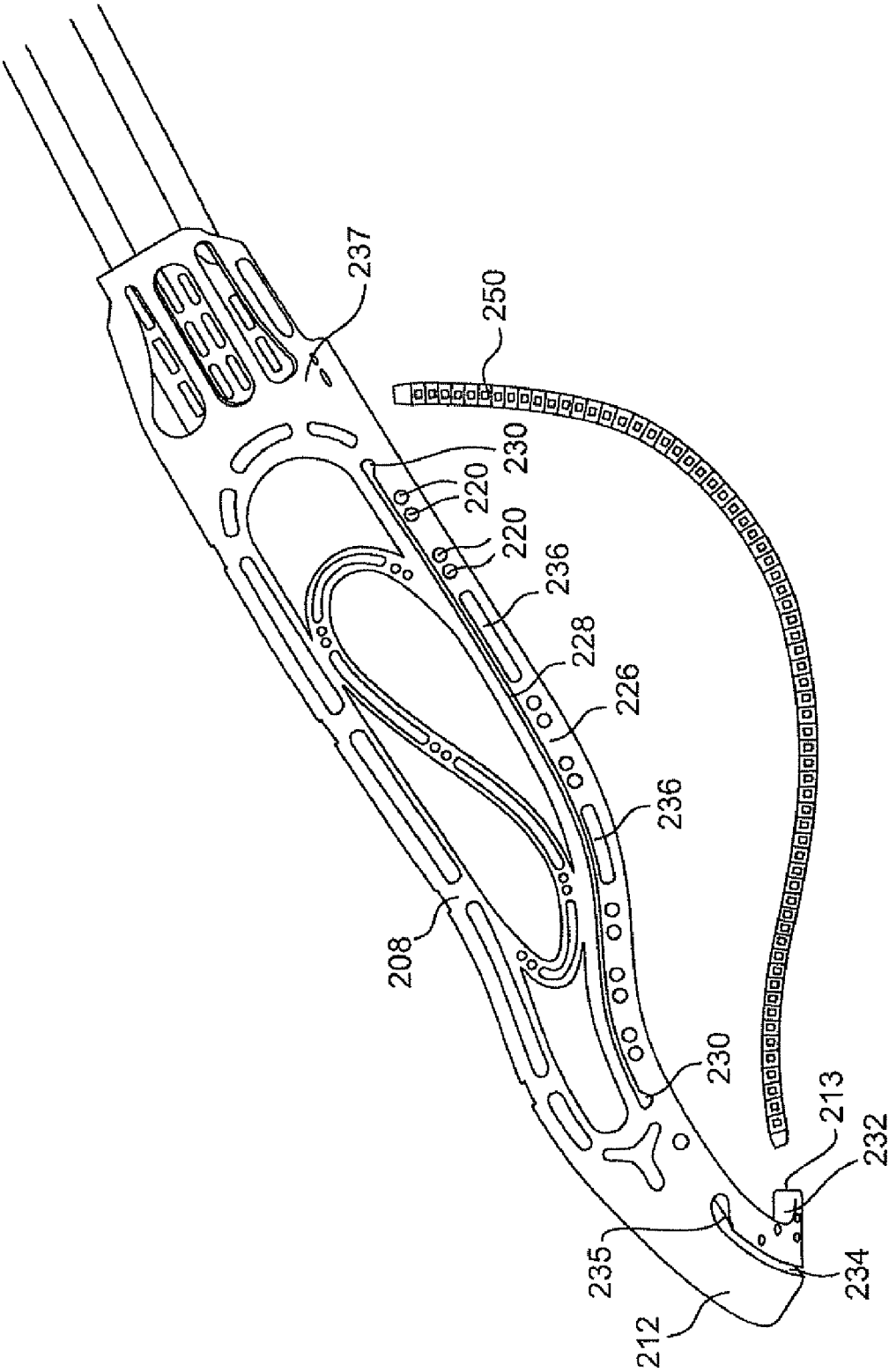

FIG. 4

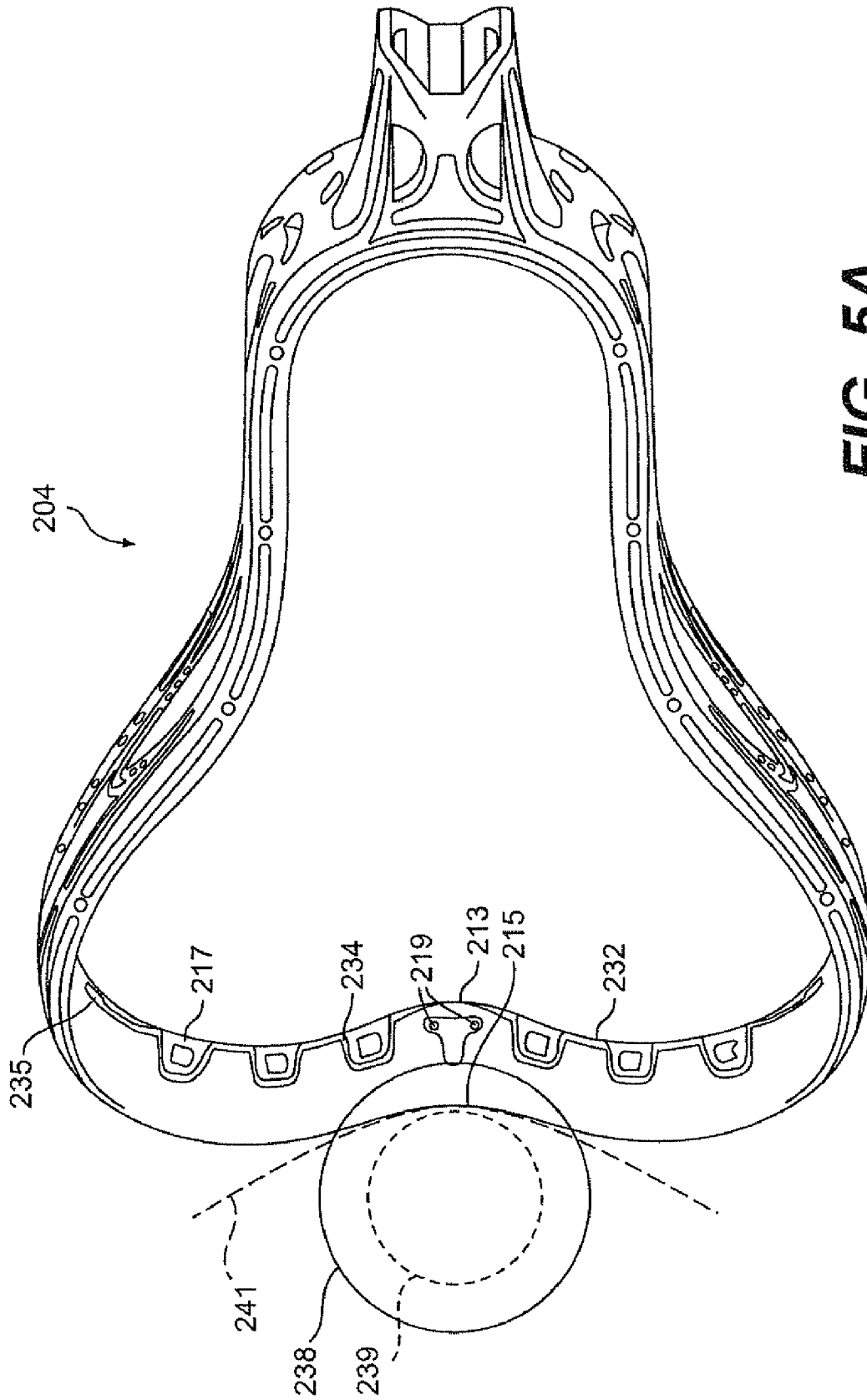

FIG. 5A

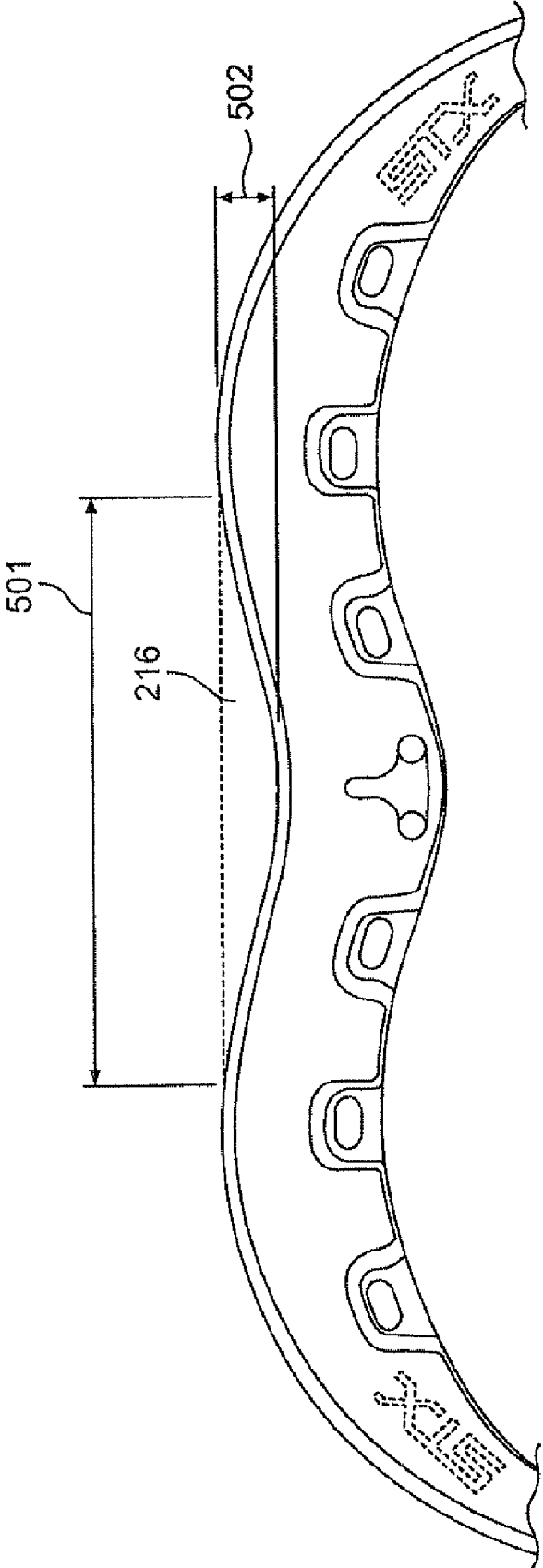

FIG. 5B

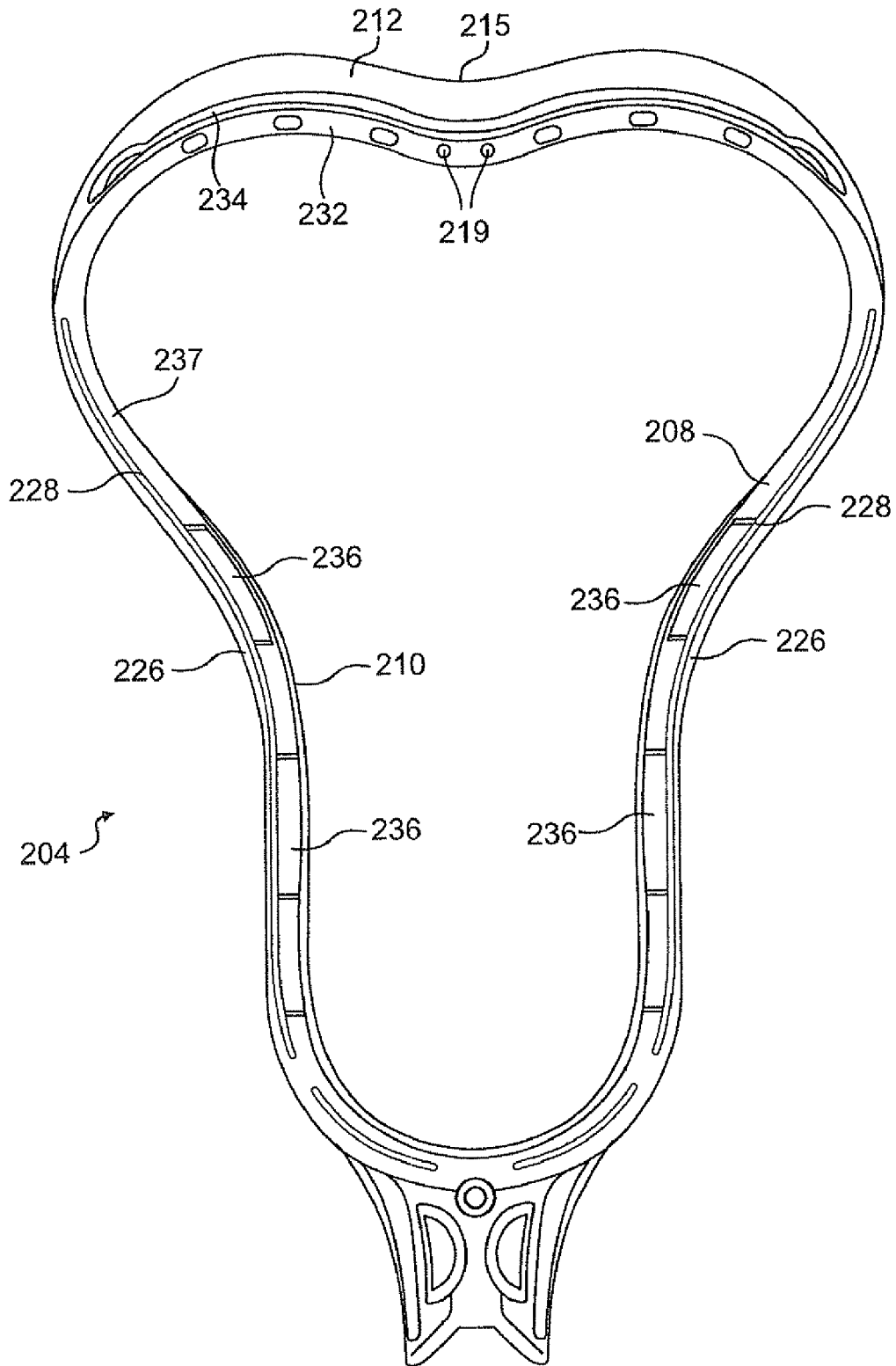

FIG. 6

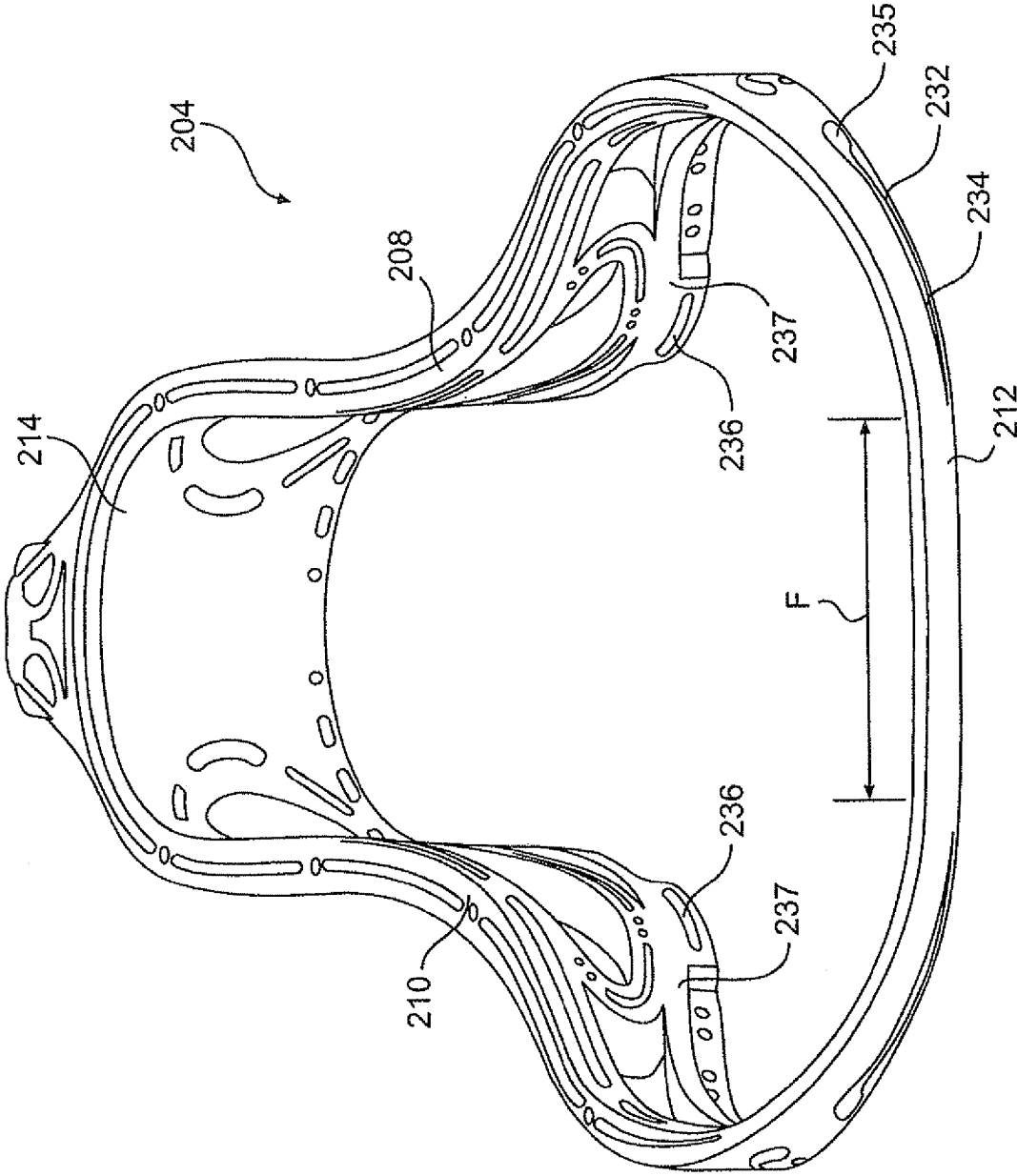

FIG. 7

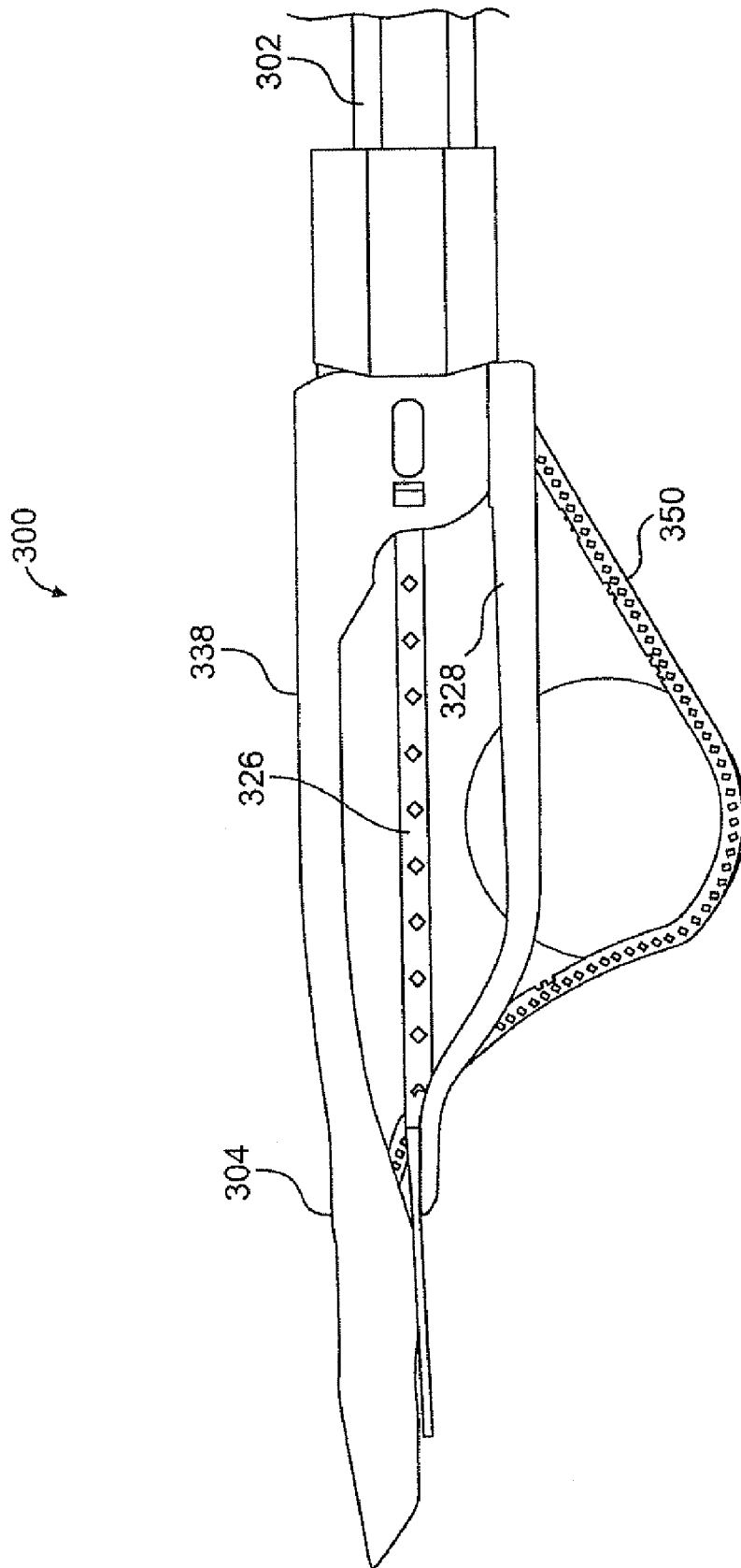

FIG. 9

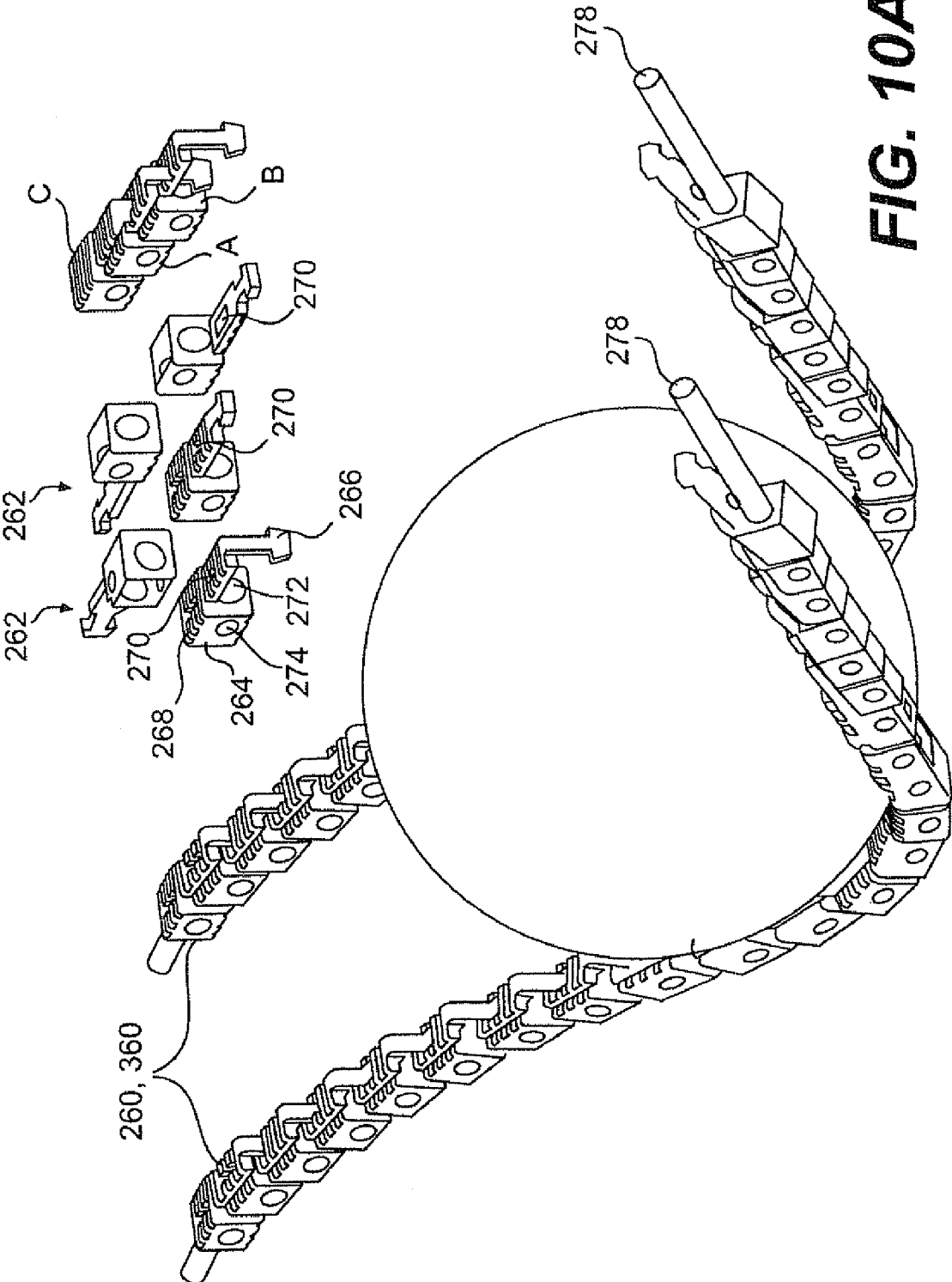

FIG. 10A

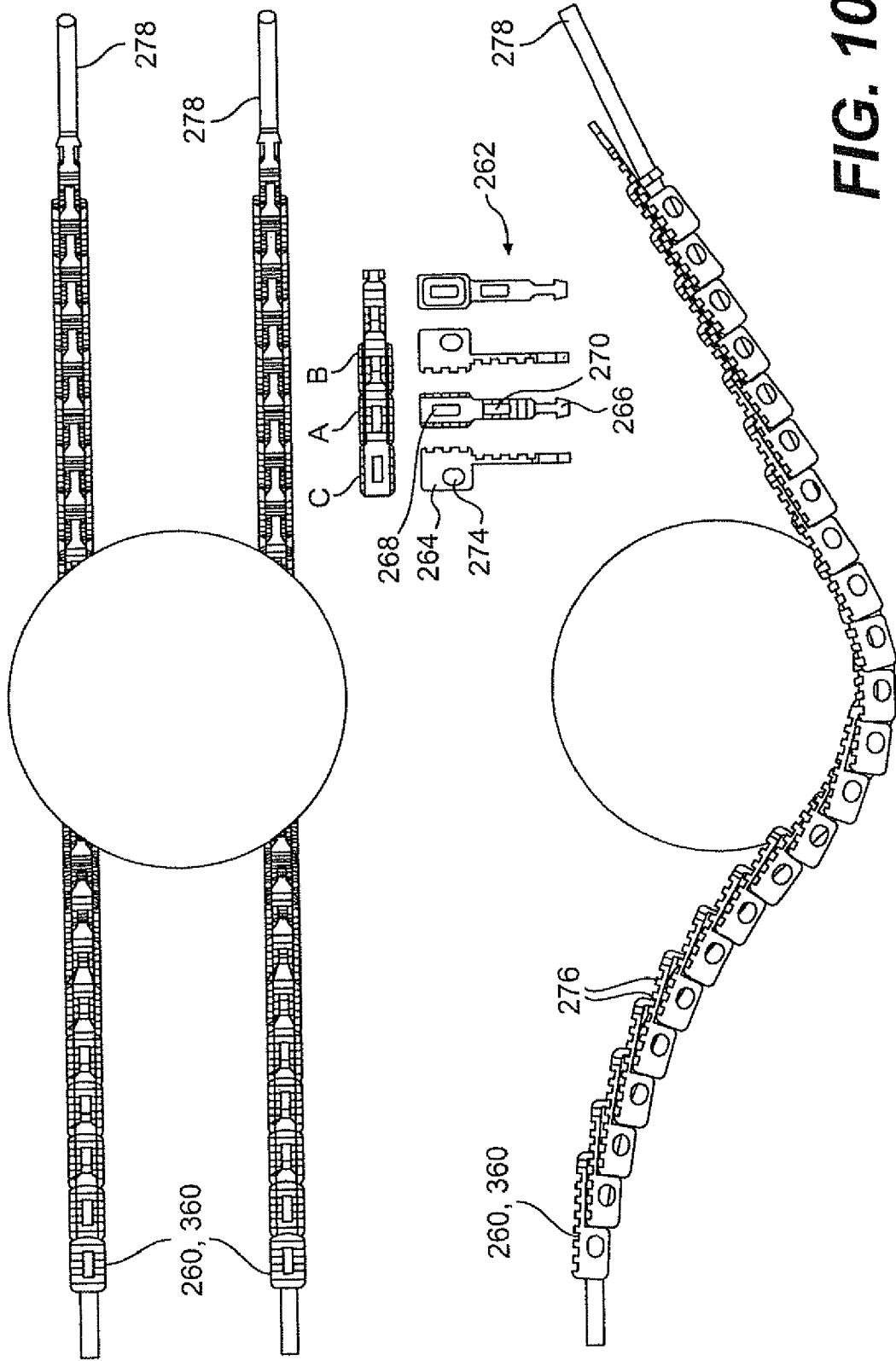

FIG. 10B

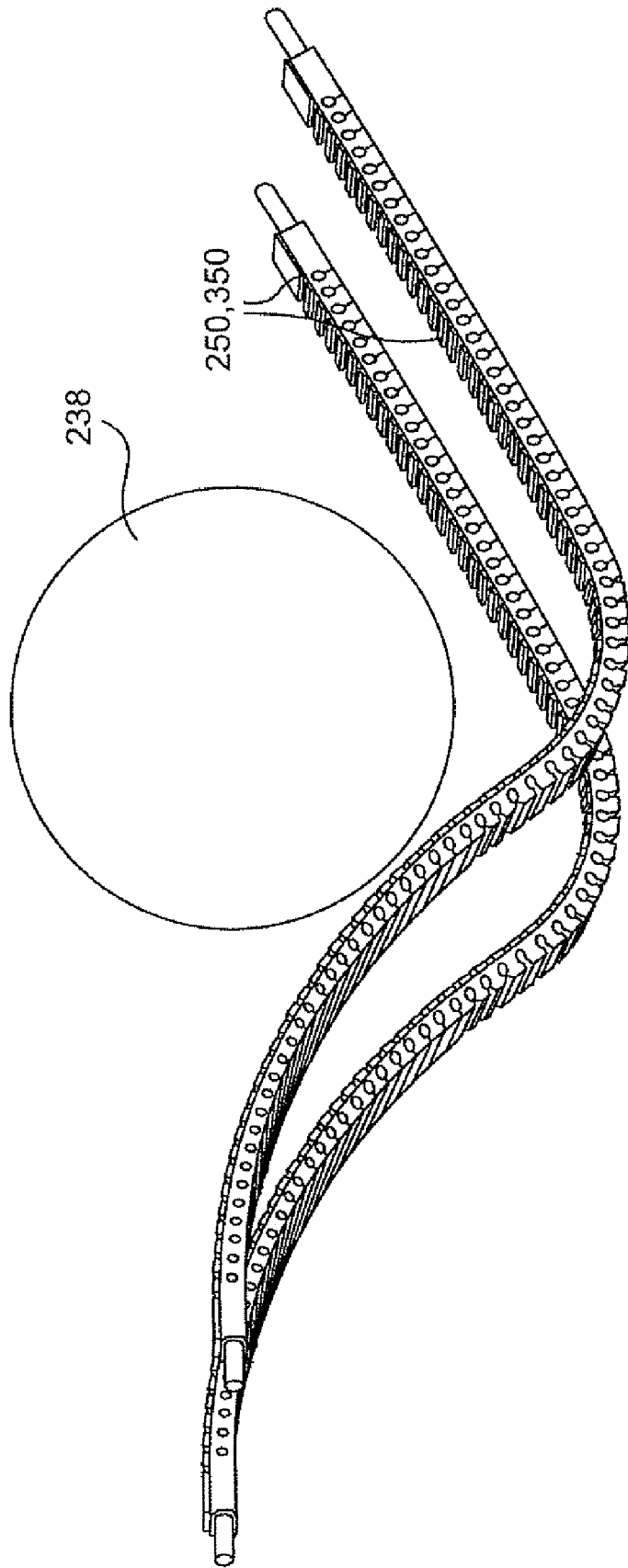

FIG. 11

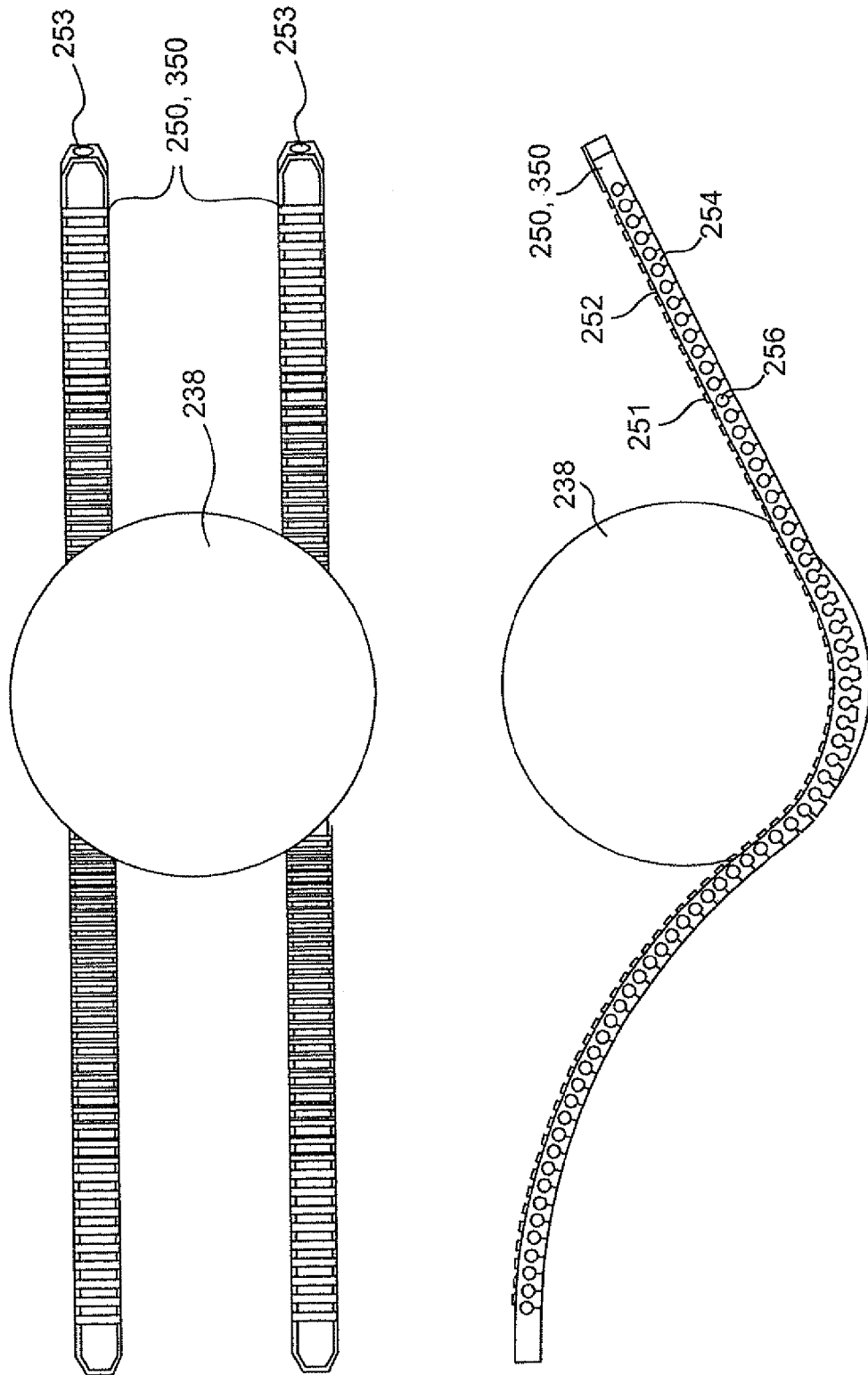

FIG. 12

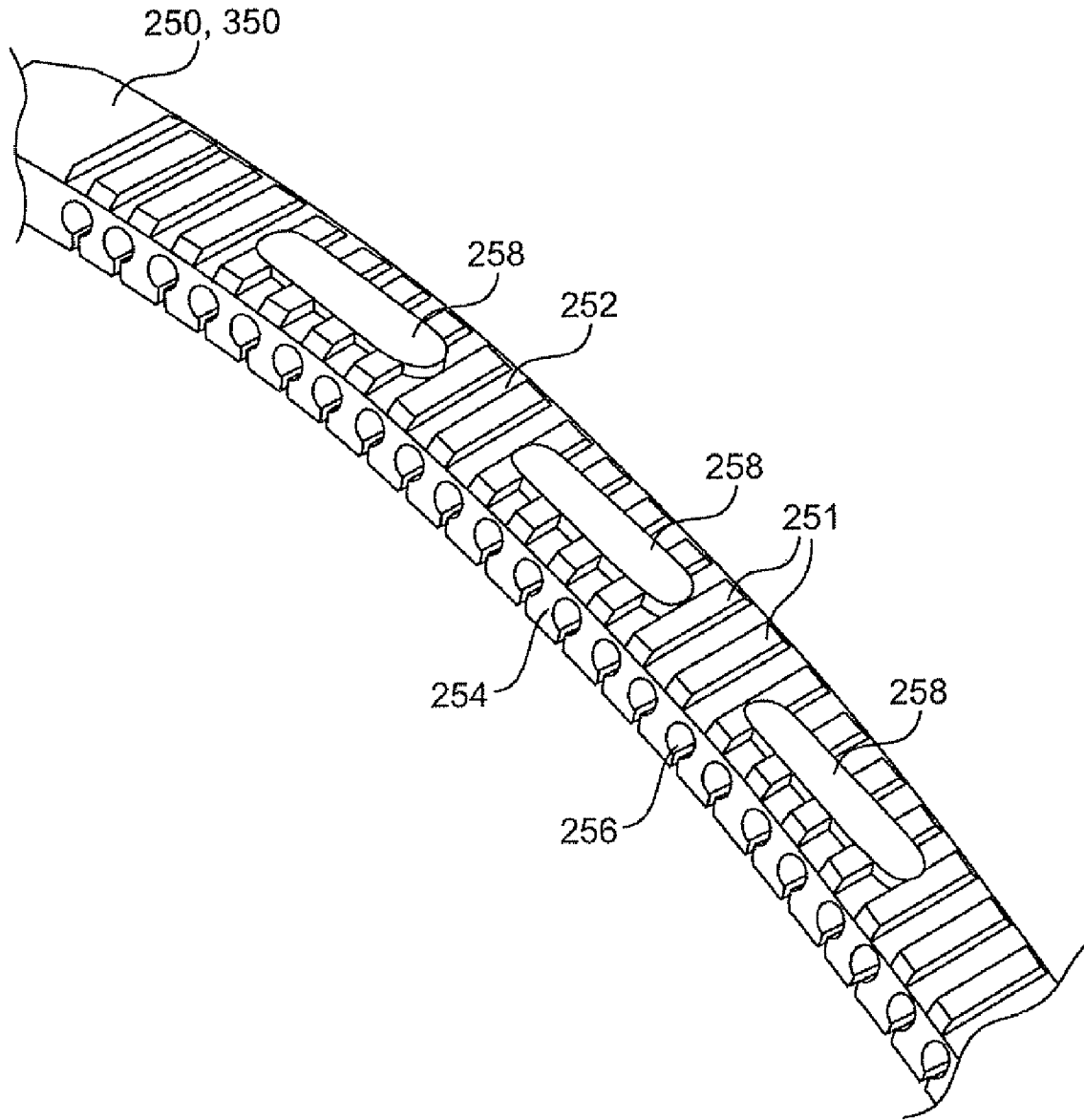

FIG. 13

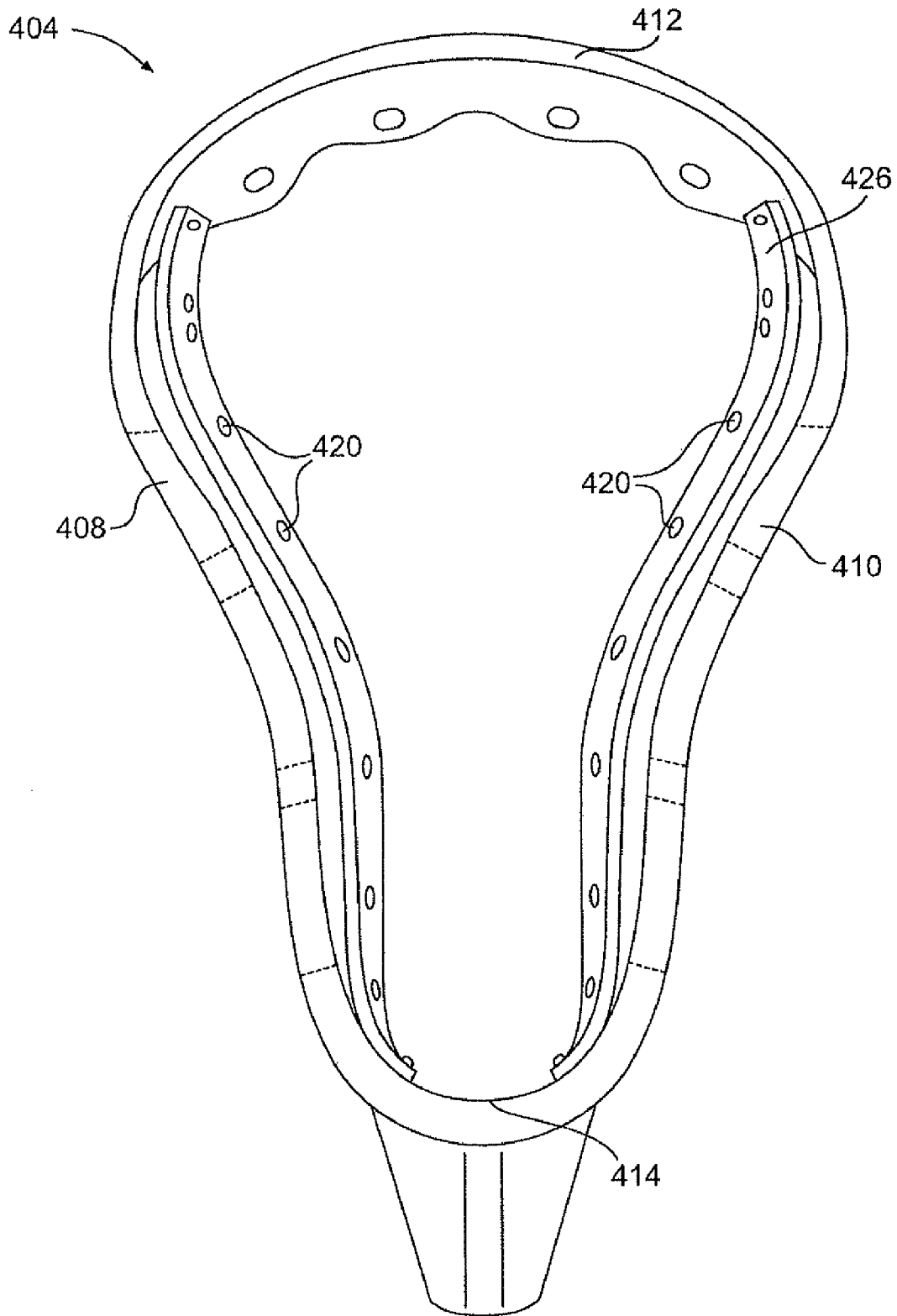

FIG. 14

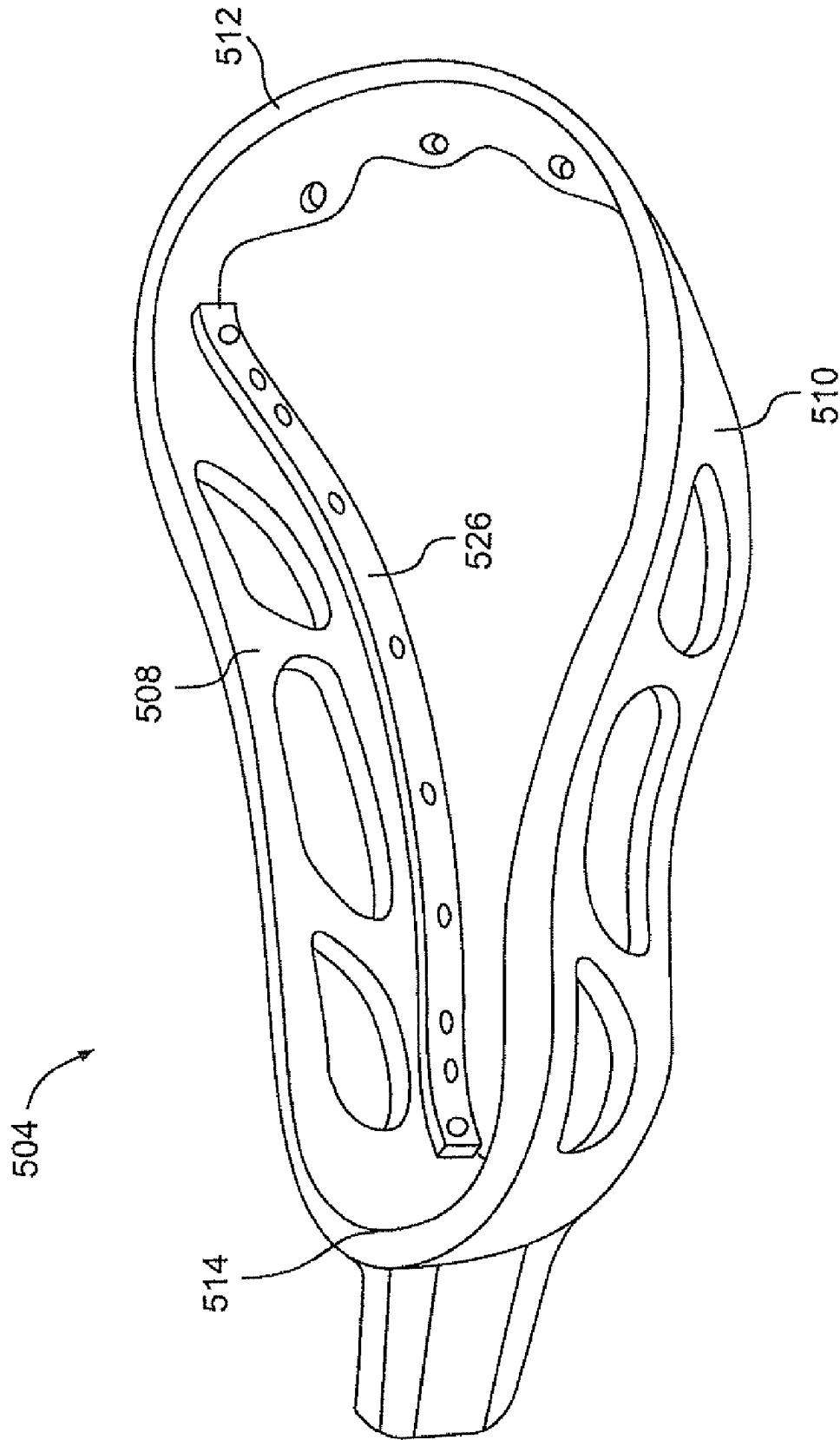

FIG. 15

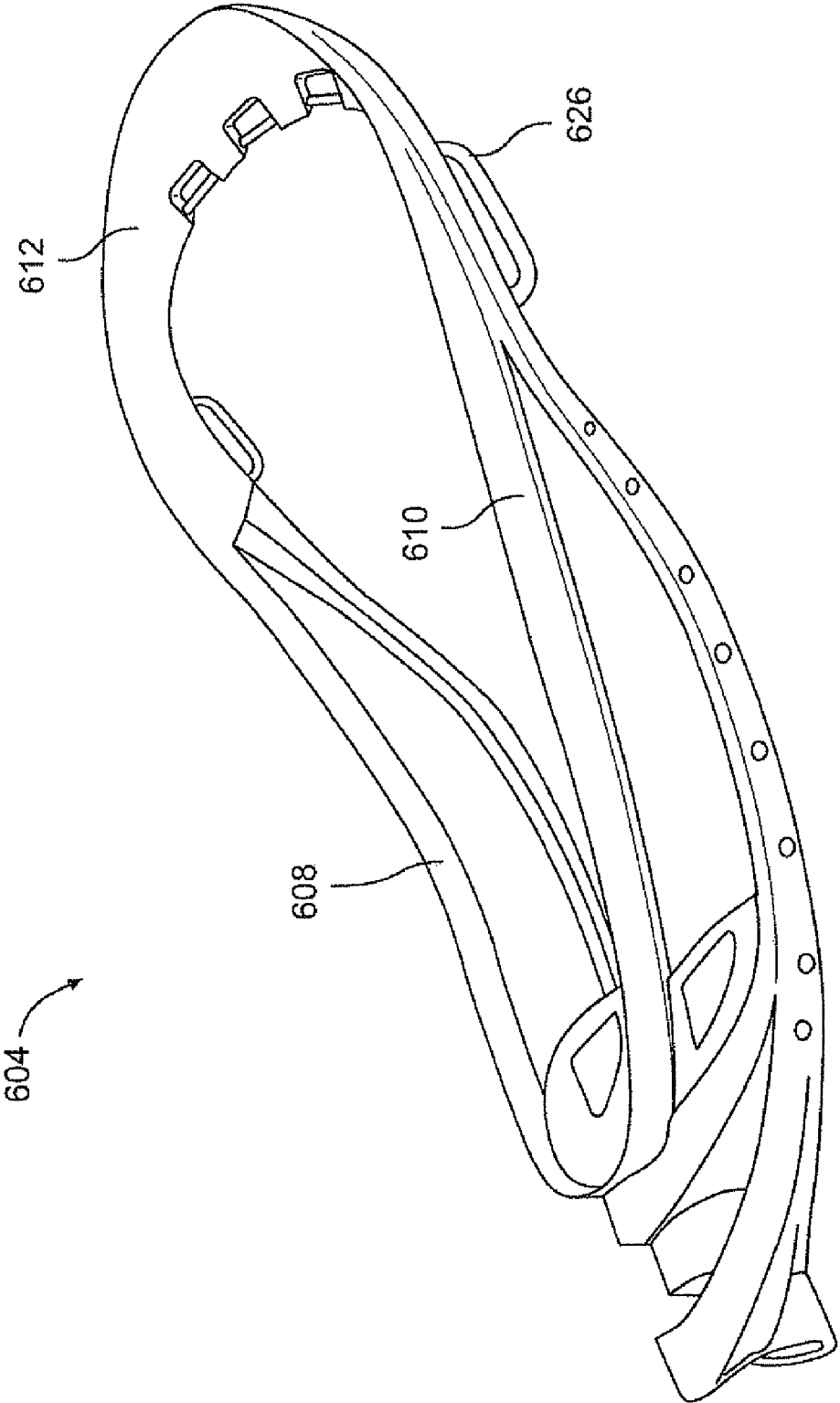

FIG. 16

LACROSSE HEAD HAVING A FLEXIBLE STRINGING MEMBER AND A RECESSED SCOOP

This application is a continuation of U.S. patent applica- 5
tion Ser. No. 11/345,321, filed Feb. 2, 2006, which claims the
benefit of U.S. Provisional Application No. 60/648,688, filed
Feb. 2, 2005, both of which are incorporated herein by refer-
ence in their entirety.

BACKGROUND

1. Field of the Invention

The present invention relates generally to lacrosse sticks,
and more particularly, to a lacrosse stick head having at least 15
one of a flexible stringing member and a recessed scoop.

2. Background of the Invention

FIG. 1 illustrates a conventional lacrosse stick **100** having
a handle **102** shown in dotted lines and a double-wall syn-
thetic head **104**. Head **104** comprises a generally V-shaped
frame having a juncture **106**, sidewalls **108** and **110**, a trans-
verse wall (or "scoop") **112** joining the sidewalls at their ends
opposite juncture **106**, and a stop member **114** joining side-
walls **108** and **110** at their ends nearest juncture **106**. As
shown, handle **102** fits into and through juncture **106**, and
abuts stop member **114**. A screw or other fastener placed
through opening **107** secures handle **102** to head **104**.

For traditionally-strung pockets (which have thongs and
string instead of mesh), thongs (not shown) made of leather or
synthetic material extend from upper thong holes **116** in
transverse wall **112** to lower thong holes **118** in stop member
114. In some designs, such as the design shown in FIG. 1,
upper thong holes **116** are located on tabs **117** of the scoop
112. On other designs, upper thong holes **116** are located
directly on the scoop **112**. FIG. 1 shows four pairs (**116**, **118**)
of thong holes that accept four thongs. To complete the pocket
web, nylon strings are threaded around the thongs and string
is laced through string holes **120** in sidewalls **108** and **110**,
forming any number of diamonds (crosslacing). Finally, one
or more throwing or shooting strings extend transversely
between the upper portions of sidewalls **108** and **110**, attach-
ing to throwing string holes **124** and a string laced through
string holes **122**. A handle or shaft **102** is disposed in juncture
106 of head **104** and is secured to head **104** with a screw or
similar fastener placed in opening **107**. The typical features of
a lacrosse stick are shown generally in Tucker et al., U.S. Pat.
No. 3,507,495, Crawford et al., U.S. Pat. No. 4,034,984, and
Tucker et al., U.S. Pat. No. 5,566,947, which are all incorpo-
rated by reference herein.

Conventional rigid lacrosse heads that string the pocket
directly to the rigid frame frustrate a manufacturer's ability to
satisfy divergent performance characteristics. For example,
to provide better ball control during face-offs or when scoop-
ing ground balls, a player may prefer a strong but deformable
lacrosse head that returns to its original shape once the
deforming force is removed. At the same time, a player may
desire a less rigid, vibration-dampening lacrosse head that
absorbs impacts to the lacrosse head by other sticks to help
prevent a ball from being jarred from the head. With a con-
ventional rigid head that strings the pocket directly to the rigid
frame, the manufacturer must choose a material that serves
both of these disparate purposes. Although the manufacturer
can compensate somewhat for this performance tradeoff by
using structural elements (e.g., increasing the thickness of the
sidewalls), the practical result of the tradeoff is a lacrosse
head that satisfies neither purpose optimally.

There are many other examples of these types of tradeoffs
in choosing a material for a conventional rigid lacrosse head.
For example, providing the necessary rigidity in a lacrosse
head can compromise the ability to provide a dampening
pocket. In an effort to deepen a pocket as much as possible,
some conventional men's lacrosse heads maximize the height
of the sidewalls to the upper limit of 2 inches that is mandated
by applicable rules. Unfortunately, maximizing the height of
the traditional rigid sidewall does not enhance the flexibility
of the pocket in any way. The rigid frame of the traditional
lacrosse head can make the overall catching area stiff and
unforgiving. Indeed, the only non-rigid component of the
conventional men's lacrosse head is the pocket. A sharp jolt to
the stick, as often happens when a player is checked, can
cause the stiff frame to jerk the pocket and propel the ball out
of the lacrosse head. Players would therefore prefer a less
rigid lacrosse head that better dampens the pocket to keep a
ball in the lacrosse head.

Another example of a performance tradeoff concerns the
rigidity of the lacrosse head frame in relation to the tightness
of the pocket strings. With conventional rigid lacrosse heads
that attach the pocket directly to the rigid frame, the stiffer the
material of the head, the less the head flexes or "gives" in
response to tension on the pocket. As a result, the pocket in a
women's lacrosse head can become excessively tight, such
that impact with the ball causes a trampoline effect that makes
the ball hard to catch and control. In essence, the pocket,
strung on a rigid unforgiving frame, acts like the strings of a
tennis racquet and rebounds the ball out of the pocket. This
trampoline effect is especially troublesome for women's
lacrosse sticks, which have shallower and more tightly strung
pockets than men's lacrosse sticks. Again, restricted to a rigid
head that attaches the pocket directly to the rigid frame, a
manufacturer could use a more energy absorbing material to
reduce the trampoline effect. However, using a more energy
absorbing material can make the head less rigid and less
suitable for accurate passing and shooting, and for protecting
against ball-jarring hits.

Thus, there remains a need for a lacrosse head that better
satisfies the divergent performance requirements discussed
above. In particular, there remains a need for a lacrosse head
that possesses the necessary structural support while also
satisfying preferences for pocket dampening, ball control and
retention, protective cushioning, and light weight.

SUMMARY OF THE INVENTION

An embodiment of the present invention provides a
lacrosse stick having at least one of a flexible stringing mem-
ber and a recessed scoop.

In one embodiment of the present invention, a slot is
formed in a lacrosse head along a stop member, a sidewall,
and/or a scoop to provide the flexible stringing member.
When provided at the scoop, the scoop and the flexible string-
ing member can overlap each other such that no through
passage is visible through the slot when viewed in a direction
facing a ball receiving side of the head. The flexible stringing
member and lacrosse head frame can also have aligned holes
separated by a gap, with the holes configured to receive an
attachment member that adjusts the size of the gap. The
flexible stringing member provided by the slot can move in
multiple directions relative to the lacrosse head frame to
provide both dampening and narrowing of the pocket.

In another embodiment, the flexible stringing member is a
flexible stringing bar that extends from a stop member to a
scoop. A flexible stringing bar can be provided adjacent to
each sidewall, with the pocket attached to the bars. In this

manner, when a ball is received into the pocket the flexible stringing bars can move toward each other to dynamically narrow the pocket, while also dampening the pull of the pocket. This dampening and narrowing greatly enhances ball control and retention.

In another embodiment, the flexible stringing member is more flexible in one direction than another. For example, the flexible stringing member can flex more in a first direction generally from the ball receiving side of the lacrosse head toward the ball retaining side of the lacrosse head than in a second direction generally from the ball retaining side of the lacrosse head toward the ball receiving side of the lacrosse head. The greater flexibility in the first direction dampens the pocket and improves ball control. The lesser flexibility in the second direction improves passing and shooting accuracy by providing a contoured pocket against which the ball can rise and release.

Another embodiment of the present invention provides upper sidewalls that are independent of a flexible lower sidewall member. The lower sidewall member can have a cross-piece that connects two lower sidewall members. The flexible stringing member can lie over the crosspiece for further support and/or flexibility. The lower sidewall member can be disposed outwardly of the upper sidewalls to absorb impacts before the upper sidewalls.

In another embodiment of the present invention, a lacrosse head has a recess in the scoop that curves toward the stop member to increase the amount of surface area that underlies and contacts a ball when scooping.

BRIEF DESCRIPTION OF THE DRAWINGS

FIG. 1 is a schematic diagram of a lacrosse stick.

FIG. 2 is a schematic diagram illustrating a perspective view of an exemplary lacrosse stick having flexible stringing rails, a recessed scoop, and flexible pocket members, according to an embodiment of the present invention.

FIG. 3 is a schematic diagram illustrating an end view of an exemplary lacrosse head having a flexible stringing rail along a recessed scoop according to an embodiment of the present invention.

FIG. 4 is a schematic diagram illustrating a side view of an exemplary lacrosse stick having flexible stringing rails, a recessed scoop, and a flexible pocket member, according to an embodiment of the present invention.

FIG. 5A is a schematic diagram illustrating a top view of a ball receiving side of an exemplary lacrosse head having a flexible stringing rail along a recessed scoop, according to an embodiment of the present invention.

FIG. 5B is a schematic diagram illustrating an exemplary recessed scoop, according to an embodiment of the present invention.

FIG. 6 is a schematic diagram illustrating a top view of a ball retaining side of an exemplary lacrosse head having a flexible stringing rail along a recessed scoop, according to an embodiment of the present invention.

FIG. 7 is a schematic diagram illustrating a perspective end view of an exemplary lacrosse head having flexible stringing rails and a recessed scoop, according to an embodiment of the present invention.

FIG. 8 is a schematic diagram illustrating a perspective view of an exemplary lacrosse stick having a recessed scoop, flexible stringing bars, flexible side rails, and flexible pocket members, according to another embodiment of the present invention.

FIG. 9 is a schematic diagram illustrating a side view of the lacrosse stick shown in FIG. 8, according to an embodiment of the present invention.

FIGS. 10A and 10B are schematic diagrams illustrating a perspective view of flexible pocket members, along with an exploded view of components of the flexible pocket members, according to an embodiment of the present invention.

FIG. 11 is a schematic diagram illustrating a perspective view of flexible pocket members, according to another embodiment of the present invention.

FIG. 12 is a schematic diagram illustrating top and side views of the flexible pocket members shown in FIG. 11, according to an embodiment of the present invention.

FIG. 13 is a schematic diagram illustrating a perspective view of flexible pocket members having additional slots, according to another embodiment of the present invention.

FIG. 14 is a schematic diagram illustrating a top view of the ball receiving side of an exemplary lacrosse head having flexible stringing bars from the stop member to the scoop, according to another embodiment of the present invention.

FIG. 15 is a schematic diagram illustrating a perspective side view of another exemplary lacrosse head having a flexible stringing bar disposed along a sidewall, according to an embodiment of the present invention.

FIG. 16 is a schematic diagram illustrating a perspective side view of an exemplary lacrosse head having flexible stringing bars disposed on the lower edge of the upper sidewalls and near the scoop, according to another embodiment of the present invention.

DETAILED DESCRIPTION OF THE INVENTION

An embodiment of the present invention provides a lacrosse head having a flexible stringing member, for example, in at least one of the stop member, the sidewalls, and the scoop. The flexible stringing member provides additional “spring” or “give,” especially while catching and cradling, but without sacrificing too much movement in the reverse shooting direction. As used herein, a flexible stringing member refers to a member that, in response to a force such as the pull of a pocket from catching or cradling a regulation lacrosse ball, moves a greater distance than the main lacrosse head frame.

FIGS. 2-7 show an exemplary lacrosse stick 200 with a head 204 having flexible stringing rails 226 in the sidewalls 208, 210 and a flexible stringing rail 232 in the scoop 212. Both of these flexible rails 226, 232 in the sidewalls 208, 210 and the scoop 212 can be limited in their motion toward the ball receiving side of the head 204 by the main frame 237 (e.g., about 0.020 inches toward the inside taper ends of the slot openings 228, 234), but are able to flex or move away much farther (e.g., greater than 0.090 inches) from the main frame 237 when, for example, pulled by the pocket strings (not shown) in a direction toward the ball retaining side of head 204.

In an alternative embodiment, the motion of the flexible rails 226, 232 is not limited in any direction, which can be accomplished, for example, by providing a larger slot opening 228, 234. In another alternative embodiment, the flexible rails 226 can be disposed inwardly of the main frame 237, rather than outwardly as is shown in FIG. 3, so that the flexible rails 226 are unimpeded in a direction toward the interior of head 204.

The ends of the slot openings 228, 234 may be teardrop shaped 230, 235 so as to minimize the stress points during flexure of the plastic material at the end points where the flexible stringing rails 226, 232 are attached to the main frame

237. In one embodiment, in the scoop 212, the slot opening 234 is about 7.2 inches long and about 0.05 inches wide (as represented by dimension 271 in FIG. 3), with a 2 degree taper inward (toward the interior of head 204) and rounded edges, as is best shown in FIG. 3. The teardrop shapes 230, 235 at the ends of the slot are approximately 0.3 inches in diameter and the amount of material between the bottom of the teardrop shapes 230, 235 and the outside of the scoop 212 is approximately 0.12 inches (as represented by dimension 275). This amount of material can be increased or decreased, as desired, to permit more or less flexure of the material at those end points respectively.

In another embodiment, in the sidewall, the slot opening 228 is about 7 inches long measured along a straight line from end point to end point and is about 0.03 inches wide, with a 2 degree taper inward (toward the interior of the head), when viewed from a side elevation as in FIG. 4. When viewed from the bottom as in FIG. 6, the slot 228 is about 0.05 inches wide with a 2 degree taper toward the ball receiving side of the lacrosse head frame. The teardrop shapes 230 (see FIG. 4) at the ends of the slot 228 are approximately 0.18 inches in diameter and the amount of material between the bottom of the teardrop shapes 230 and the outside of the main frame 237 is approximately 0.12 inches. This amount of material can be increased or decreased, as desired, to permit more or less flexure of the material at those end points respectively.

As shown best in FIG. 5A, on the flexible rail 232 of the scoop 212, floating string attachments 217 (six in this example, but could be two or more) can be below the surface of the main scoop 212 even during full closure of the slot opening 234. The floating string attachments 217 can be constructed as described in U.S. Pat. No. 6,852,047, issued to Tucker, Sr., which is herein incorporated by reference in its entirety. The slot opening 234 at the 30 degree scooping plane is mainly behind the front scoop surface 212 so as to minimize the potential of catching a lip of the moving flexible rail 234 during ball retrieval on the ground. For example, as shown in FIG. 7, within a flat section F (e.g., 2.5 inches in width) of the scoop 212, the slot opening 234 can be "hidden" from the ground contact surface. In addition, as shown best in FIG. 5A, the scoop 212 and flexible rail 234 can overlap each other such that no through passage is visible through the slot when viewed in a direction facing a ball receiving side of the head.

As shown in FIG. 7, the flat section F may define a plane that forms an angle with the shaft axis of the head 204 of between approximately 20 to 40 degrees. Thus, the flat section F would lie flat against the ground when a player approaches a ball with the stick held at that angle, the approach angle depending on the specific size of the player and their playing style.

As shown, for example, in FIGS. 4 and 5A, the recessed or scalloped scoop 212 having recessed edge 215 and inwardly extending edge 213 enables the main scoop 212 to be farther underneath a ball 238 during the natural scooping motion. This configuration facilitates easier ball retrieval, as compared to the traditional scoop shape 112 (as shown in FIG. 1) in which the uppermost point of the scoop (farthest from the base) contacts the ball, and the portions of the scoop adjacent to the uppermost point curve back away from the ball. Indeed, with the traditional scoop 112 only a limited portion of the scoop is under the ball during scooping.

As shown in FIGS. 4 and 5A, with the scalloped scoop 212 design, upon initial contact with the ball 238, the scoop itself, and especially all of the surfaces to the left and right of the low point on the recess 215 or scalloped portion, are further underneath the ball 238. As an example, with a 2.5 inch diameter ball 238, 30 degree scoop plane, and approximately 1 inch

wide scoop, the scoop 212 may contact the ball 238 at a diameter on the ball of about 1.62 inches (represented by the dotted contact diameter line 239), roughly 0.3 inches above the surface on which the ball 238 is resting. At this location, the recessed shape 215 of the scoop 212 approximates the curve of the ball 238 and a significant portion of the scoop 212 is underneath the ball 238. This recessed shape is generally represented by the dotted line 241, representing a compound curve, with a diameter greater than 2.5 inches. Thus, with a simple (shorter) downward motion on the handle 202 (or upward motion of the scoop end), the ball 238 is more easily controlled during entry into the head 204.

In addition, given that a player may not scoop a ball with the center of the ball perfectly on center with the head 204, the scalloped scoop design 212 can provide at least two points of contact with the ball 238 (and can provide more scoop initially farther underneath the ball) for easier pickup and control during entry into the head 204. For example, if the radius of curvature of the recessed scoop 212 is smaller than the radius of curvature of the contact diameter of the ball 238, then the recessed scoop 212 can contact the ball 238 at least at two points. Relative to the exemplary embodiment described above in which a representative contact diameter is approximately 1.62 inches (FIG. 5A), a radius of curvature of the recess could be approximately 0.9 inches or less. As a skilled artisan would appreciate, the appropriate radius of curvature of the recess would depend on the height at which the scoop contacts the ball, as determined by, for example, the angle and width of the scoop and the angle at which the stick is held relative to the ground when scooping the ball.

FIG. 3 illustrates dimensions of an exemplary lacrosse head having a recessed scoop, according to an embodiment of the present invention. As shown, when viewed in a direction along the shaft axis, the angle of incline α of the scoop 212 from the center point of the scoop preferably is a maximum of approximately 30 degrees. As shown in FIG. 5B, when viewing the ball receiving side of the head, the recess area 216 can be about 0.2 to about 1.32 square inches. The width 501 of the recess area 216 could be about 0.3 to about 2.4 inches. The depth 502 of the recess area 216 (center point of scallop recess distance) could be about 0.2 inches to about 1.4 inches. The approximate area of the scoop 212 under a ball 238 (total left and right combined) could be about 0.02 to about 4.5 square inches.

As shown, for example, in the bottom view of FIG. 6 and in FIGS. 4 and 7, the flexible rails 232, 226 on the scoop 212 and sidewalls 208, 210 can also have aligned holes or slots 219, 236 through both the main frame 237 and the flexing rails 232, 226 to provide additional pocket adjustment. As shown best in FIG. 3, in this area, the main frame 237 and the flexible rails 226, 232 can be spaced apart by a gap of approximately 0.05 inches (as represented by dimensions 273) with a 2 degree taper toward the ball receiving side of head 204 and rounded edges. The spring wall adjustment string holes and slots 219, 236 can be used to connect the main frame 237 to the moving flexible rails 232, 226, to accommodate desired performance characteristics. On the scoop 212, there may be two holes 219 at the center that can be strung through either loosely, tightly, or not at all to adjust the permissible motion of the entire flexible scoop member 232. The flexible side rails 226 are shown with two similar slots 236 (could also be holes) that serve the same adjustability function with respect to the main frame 237 itself.

The flexible scoop rail 232 can be limited in motion toward the ball receiving side of the head by the more rigid main frame 237. Similarly, movement of the flexible side rails 226 may be limited toward the interior of head 204 by the main

frame 237, limiting the potential for fracture during stick or body checks regularly delivered to the outside frame during lacrosse play. There are also openings 220 for attaching string members solely to the flexing side rail members 226.

As shown in FIGS. 2 and 4, an exemplary lacrosse head in accordance with an embodiment of the present invention may include flexible pocket members 250 either in addition to or instead of the flexible stringing rails 226, 232. The flexible pocket members 250 may be configured to provide additional flexure upon impact with a ball being caught, thrown, or cradled. The flexible pocket members 250 can be formed of a material or a series of elements that is configured to be more flexible when forced in one direction (e.g., toward the ball retaining side of a head) and less flexible when forced in an opposite direction (e.g., toward the ball receiving side of a head). The flexible pocket members further provide a channel that guides the travel of the ball in and out of the pocket, to enable better ball control and more accurate throwing.

To provide flexible pocket members 250 that are more flexible in one direction and less in the opposite direction, the members 250 may be made of a continuous length of material such as that shown in FIGS. 11-13. As shown in FIG. 12, the member 250 is constructed such that the top portion 252 of member 250 is continuous while the bottom portion of member 250 comprises a plurality of separated protrusions 254 that extend downwardly from the top portion 252 and are in contact but not attached to one another. The protrusions 254 are shaped to just be in contact with one another when the flexible pocket member 250 is oriented in a straight line. Alternatively, the protrusions 254 can be configured to be oversized such that, instead of a straight line, the natural orientation (in the absence of other forces) of the flexible pocket member is to be concave when viewing a head from a side elevation. In another alternative, the protrusions 254 can be configured to be undersized such that the natural orientation of the flexible pocket member is convex when viewing a head from a side elevation.

In another embodiment, the protrusions may not touch each other when the member is in its natural orientation (e.g., concave, straight, or convex), to allow more flexibility when forced in a direction toward the ball receiving side of the head. In other words, when forced in a direction toward the ball receiving side of the head, the member would flex, and the protrusions would come together and eventually touch each other and prevent further flexing of the member.

In any of the above described embodiments of continuous flexible pocket member 250, lateral through-holes 256 may be provided that extend across the width of the member that allow strings to be threaded transversely through member 250 in order to form a pocket in the lacrosse head 204. Further, as shown in FIG. 13, slots 258 may be provided in the continuous flexible pocket members 250 transverse to through-holes 256. Slots 258 may be cut out of the top portion 252 of the flexible pocket members 250 and contribute to overall weight reduction and increased flexibility due to the removal of material. In addition, it is possible to thread pocket strings through the slots 258 and therefore provide additional stringing configurations.

As an alternative or in addition to continuous flexible pocket member 250, a lacrosse head may include adjustable length flexible pocket members 260, as shown in FIGS. 10A-B. Adjustable length flexible pocket members 260 may comprise a length of inter-engaging elements 262. In a similar manner to the protrusions 254 of continuous flexible pocket member 250, the elements 262 of adjustable length flexible pocket member 260 provide more flexibility to member 260 when member 260 is forced in a direction toward the ball

retaining side of the head and less flexibility when member 260 is forced in a direction toward the ball receiving side of the head. This variable flexibility is provided by the interlocking of tab 266 and notch 268, 270 elements on the top portion of the member 260 and the separability of body elements 264 on the bottom portion of the member 260.

Each of the inter-engaging elements 262 may include a body 264, a tab 266, a body notch 268, a tab notch 270, a longitudinal through-hole 272, and a lateral through-hole 274. To assemble the adjustable length flexible pocket member 260, a tab 266 of a first inter-engaging element A is inserted into a tab notch 270 of a second inter-engaging element B, as shown in FIGS. 10A-B. In so doing, the length of the tab 266 of the element A is aligned with the length of the tab notch 270 of the element B when it is inserted, and the element A is then rotated to lock the tab 266 of element A in the notch 270 of element B and to align the elements A and B. The first element A is then positioned so that its tab notch 270 lies over the body notch 268 of the second element B. A third inter-engaging element C is then provided and its tab 266 is simultaneously inserted into both the tab notch 270 of the first element A and the body notch 268 of the second element B. The third element C is then rotated to lock the tab 266 into the two notches 268, 270 of the elements B, A, respectively, and to align the body longitudinally. The process is then repeated for a fourth element (not shown) and so on until the adjustable length flexible pocket member 260 has reached a desired length.

FIGS. 10A-B also show strings 278 that are threaded through the series of longitudinal through-holes 272 formed by successive inter-engaging elements 262. These optional strings 278 may be inserted into the flexible pocket member 260 for added stability, form, or strength, as the user may find necessary. The lateral through-holes 274 may be used for cross-strings (not shown) or throwing strings (not shown) that may form the rest of the pocket. The flexible pocket members 260, cross-strings, and throwing strings may all be configured according to the specific needs of a user in order to achieve the ideal shape for the pocket.

As shown in FIG. 12, the flexible pocket members 250 may also include longitudinal through-holes 253 and lateral through-holes 256 to enable pocket strings to be threaded through the flexible members 250 in a similar manner as described above with respect to adjustable length flexible pocket members 260.

While the figures show an exemplary lacrosse head having flexible pocket members 250, 260 extending from the stop member 214 area to the scoop 212 area, the present invention also contemplates the flexible pocket members 250, 260 extending in other directions across the frame, such as laterally across the pocket. The flexible members 250, 260 may be attached to each of the sidewalls 208, 210 or any other appropriate member (e.g., stop or scoop) of the head to run across the width of the pockets. Such a configuration may provide the pocket with additional flexural capabilities, thus improving the catching and throwing characteristics of the lacrosse head.

The present invention further contemplates an embodiment in which the flexible members 250, 260 do not extend continuously from stop member 214 to scoop 212 or from sidewall 208 to sidewall 210. The flexible pocket members 250, 260 in accordance with this aspect of the invention may extend only partially across the pocket with one end attached to either the stop member 214, the scoop 212, or a sidewall 208, 210, or the flexible pocket member 250, 260 may not be attached to any part of the frame and may instead be wholly strung into the pocket. Alternatively, a lacrosse head may comprise a plurality of flexible pocket members 250, 260 that

extend intermittently across a pocket such that more than one piece of the flexible pocket member **250**, **260** extends along a single string line.

Additionally, flexible pocket members **250**, **260**, may include bumps, ridges, grooves, or nubs that may enhance ball grip. For example, as shown in FIG. **12**, flexible pocket member **250** may include nubs **251** disposed along the length of the top portion **252** of the member **250**. Likewise, individual inter-engaging elements **262** that form adjustable length flexible pocket member **260**, as shown in FIGS. **10A-B**, may include raised ridges **276** that enhance ball grip.

The adjustable length flexible pocket members **260** and the continuous flexible pocket members **250** may be formed of any suitably flexible material, such as urethane or an elastomer.

FIGS. **8** and **9** illustrate an exemplary lacrosse stick **300** with a head **304** having a recessed scoop **312**, flexible stringing bars **326**, upper sidewalls **338**, a flexible lower sidewall member **328**, and flexible pocket members **350**. The recessed scoop **312** has characteristics similar to the recessed scoop **212** in the embodiment of the invention depicted in FIGS. **2-7**.

The flexible pocket members **350** may have the same characteristics as flexible pocket members **250** and are labeled as equivalents in FIGS. **11-13**. Alternatively, adjustable length flexible pocket members **360**, as shown in FIGS. **10A-B**, are equivalent to the previously described adjustable length flexible pocket members **260** and may be used in addition to or instead of flexible pocket members **350** in the same way as is described above with reference to the interchangeability of adjustable length flexible pocket members **260** and continuous flexible pocket members **250**. In either case, flexible pocket members **350** or **360**, when oriented longitudinally (from stop member **314** to scoop **312**), provide a guide track that may increase the accuracy and speed of a thrown ball, among other advantages.

FIG. **8** illustrates a rigid upper frame on the ball receiving side of head **304** comprised of upper sidewalls **338** and scoop **312**, according to an embodiment of the present invention. Upper sidewalls **338** extend from stop member **314** and are connected on their sides opposite stop member **314** by scoop **312**. Upper sidewalls **338** may have a cross-section that helps maximize rigidity and overall strength of the head **304**, such as the triangular shape shown in FIG. **8**. The scoop **312** may have a cross-section designed to accommodate the flexibility desired in scooping balls, such as a somewhat flat or oval shaped cross-section as shown in FIG. **8**. The rigid triangular cross-section of upper sidewalls **338** gradually transitions into the flat or oval shaped cross-section of the scoop **312**. This transition may be at the widest portion of the lacrosse head **304** or may be located at any other location along the head **304**, such as at a location halfway between the stop member **314** and scoop **312**. In this manner, this embodiment of the present invention can optimize the strength, rigidity, and flexibility of the upper frame of head **204** by combining rigid upper sidewalls **338** in the rear portion of the head (i.e., toward the stop member **314**) with a more flexible scoop **312** in the forward portion of the head (i.e., toward the scoop **312**). Such optimization can satisfy desired performance characteristics of the head **304**, such as the ability to withstand and deliver checks while also allowing for flexibility in scooping balls.

The embodiment of the present invention shown in FIGS. **8** and **9** additionally includes a flexible lower sidewall member **328**. The lower sidewall member **328** includes a left member **330** extending from stop member **314**, a right member **332** extending from stop member **314**, and a crosspiece **334** joining the left and right members **330**, **332** at their ends opposite

stop member **314**. The lower sidewall member **328** enhances the ability of the lacrosse head to absorb shock imparted by a check from another stick, or from some other impact, and to better protect the ball **238** during catching, throwing, or cradling, as described in more detail below. The crosspiece **334** of the lower sidewall member **328** extends beneath the strung pocket and may act as a “throwing” or “shooting” bar, similar to a “throwing” or “shooting” string as used in traditional lacrosse pockets to increase the speed and accuracy of a thrown ball.

In one embodiment, lower sidewall member **328** is conveniently interchangeable with head **304**. The lower sidewall member **328** may be interchangeable in that no pocket strings **336** are fixed to it and that the lower sidewall member **328** does not connect to the upper sidewall **338** except for their mutual connection to a stop member **314**. The lower sidewall member **328** may be connected to the stop member **314** by a snap-in fitting, a set screw, or any other suitable fastening device.

To reduce the force imparted to the pocket of the lacrosse head **304**, the width between the left and right members **330**, **332** of lower sidewall member **328** may be larger than the width between upper sidewalls **338** such that a stick or other object moving toward the head **304** from the side or back will contact the lower sidewall member **328** first before contacting the upper sidewall **338**. In this way, the lower sidewall member **328** may take an initial hit and flex to greatly reduce or eliminate the force transferred to the pocket and ball, since no strings **336** are attached to lower sidewall member **328** and there is a space between lower sidewall member **328** and the pocket, as seen in FIG. **8**.

The head **304** may include flexible stringing bars **326** that support the pocket strings **336** and provide form to the pocket. The flexible stringing bars **326** may extend from an attachment point close to the stop member **314** to an attachment point located on or close to the scoop **312**. In one embodiment, the flexible stringing bars **326** are disposed inwardly (toward the center of the head) of the upper sidewalls **338** and/or the lower sidewall member **328**, which can provide, for example, a more narrow ball retaining structure in comparison to the wider ball receiving structure provided by the upper sidewalls **338**. The flexible stringing bars **326** can also provide additional cushioning and flexure in the pocket when a ball is caught, thrown, or cradled, thus making the lacrosse head **304** more maneuverable and forgiving. The flexible stringing bars **326** may extend and lie over the crosspiece **334** in order to take advantage of their combined flexibility and guide track-forming characteristics. The flexible stringing bars **326** can be made of any suitably durable and flexible material, such as urethane or an elastomer.

In the embodiment shown in FIGS. **8** and **9**, flexible pocket members **350** extend from stop member **314** to scoop **312** and the cross strings **336** extend from side to side and attach to the stringing bars **326** at string holes **320**. In this manner, a ball guide track is formed by the flexible pocket members **350**, which hang over the free-floating crosspiece **334** of the lower sidewall **328**, and the amount of strings used is minimized. A further advantage of this arrangement is that the strings **336** are placed between the ball **238** and the lower sidewall member **328** so that rattling is reduced.

The present invention also contemplates an embodiment in which the flexible pocket members **350** extend from side to side and the cross strings **336** extend from stop member **314** to scoop **312**. In either case, the cross strings **336** may be configured to pass through string holes in flexible pocket members **350** or **360** as described above with regard to flexible pocket members **250** and **260**.

11

In alternative embodiment of the head **304** shown in FIGS. **8** and **9**, lower sidewall member **328** does not include cross-piece **334**, and instead includes only left and right members **330**, **332** extending from stop member **314**. In this embodiment, left and right members **330**, **332** may terminate at a free end in the forward portion of head **204** near scoop **312**.

FIG. **14** is a schematic diagram of an exemplary lacrosse head **404** having flexible stringing bars **426** from the stop member **414** to the scoop **412**, according to an embodiment of the present invention. As shown by this example, each stringing bar **426** can be attached to the scoop **412** and the stop member **414**, and can span the lacrosse head frame **404** for substantially the length of a sidewall **408**, **410**. In spanning the frame **404**, the stringing bars **426** can be inside the sidewalls **408**, **410**, i.e., the stringing bars **426** are above the lower edge (at the ball retaining side) and below the upper edge (at the ball receiving side) of the sidewalls **408**, **410** when viewed from a side elevation. The stringing bars **426** can include thread holes **420** to which a pocket can be strung.

The stringing bars **426** can connect to the lacrosse head frame **404** in any number of ways including, for example, Christmas tree-type fasteners in two or more locations (e.g., lower and higher). In another embodiment, a stringing bar **426** could be part of a mesh pocket, with the stringing bar **426** attaching to the frame **404**.

In one implementation, the stringing bar **426** is part of the manufactured head frame **404**. In another implementation, the stringing bar **426** can be separately attached to the head frame **404** in different positions to enable customization. In another implementation, the flexible stringing bar **426** can hang below portions of the head frame **404** so that, in a strung head, the ball may be carried, for example, lower in the rear portion of the head (closer to the stop member) than in the forward portion of the head (closer to the scoop).

A lacrosse head **404** according to this embodiment could be adapted for men's lacrosse in that at least a portion of a ball resting in the pocket can be disposed above the lower edge of the frame **404** for compliance with the widely accepted rules of lacrosse.

FIG. **15** is a schematic diagram of another exemplary lacrosse head **504** having a flexible stringing bar **526** along a sidewall **508**, according to an embodiment of the present invention. In comparison to the head **404** of FIG. **14**, the head **504** of FIG. **15** illustrates slightly different attachment points and positioning. A flexible stringing bar **526** may be disposed on one or both of the sidewalls **508**, **510**.

FIG. **16** is a schematic diagram of an exemplary lacrosse head **604** having flexible stringing bars **626** disposed on the lower edge of the upper sidewalls **608**, **610**, in the forward portion of head **604** near the scoop **612**, according to an embodiment of the present invention. The stringing bars **626** may be formed of a stiff material that allows little deflection or they may be formed of a material having relatively more flexibility, which would allow for greater deflection and, thus, a greater ability to absorb impact.

In an important aspect of the present invention, embodiments of the invention can both dampen and narrow a pocket to greatly enhance ball control. The dampening can occur primarily in response to a force directed toward the ball retaining side of the head, for example, when a ball is received into the head and hits the pocket. The dampening can also occur in other directions or combinations of directions within the head, such as laterally from sidewall to sidewall as the pocket is pulled during cradling. The flexible frame and pocket members described above, such as flexible stringing rails **226**, **232**, flexible stringing bars **326**, and flexible pocket members **250**, **350**, **260**, **360**, can provide this dampening.

12

The dampening prevents a trampoline effect that would propel the ball out of the pocket. In other words, in response to the pull of the pocket, the flexible members can flex, dampen the pull of the pocket, and then gradually recover to their original position without excessive rebound.

The narrowing of the pocket occurs as flexible members of the frame or pocket move in a direction generally toward the interior of the head. For example, with reference to FIG. **8**, the flexible stringing bars **326** can flex toward each other (e.g., toward the centerline of head **304**) when a ball is received in the pocket and can effectively narrow the pocket and help retain the ball within the pocket. The distance between the flexed bars **326** would be less than both the distance between the bars **326** in their non-flexed position and also the distance between the upper sidewalls **338**. This narrowing can occur simultaneously with the dampening of the pocket in response to a force in the direction from the ball receiving side of the head toward the ball retaining side of the head (e.g. a force from a ball entering the head and pocket). As another example, the flexible stringing rails **226** in FIG. **2** could also be configured to flex toward the interior of the head and effectively narrow the pocket. Thus, the present invention can dampen the force of a ball entering a head, as well as narrow the pocket to retain the ball in the head.

As one of ordinary skill in the art would appreciate, any of the heads **204**, **304**, **404**, **504**, or **604** depicted in the figures may be strung with either a traditional thong and cross-string type pocket or a mesh pocket, and may in either case retain the advantages of the disclosure.

In addition, although the above embodiments of the present invention describe flexible members (e.g., flexible pocket members, flexible stringing rails, and flexible stringing bars) as disposed in certain locations of the head, one of ordinary skill in the art would appreciate that these flexible members could be provided in any location of a head appropriate for providing the desired performance characteristics. For example, a flexible stringing rail similar to the rails **232**, **226** of FIG. **2** could be provided in the stop member of head **204**. Likewise, a flexible stringing bar similar to the bars **326** of FIG. **8** could be provided at the stop member of head **304**, for example, attaching both ends of the bar to two different locations on the stop member. As another example, a flexible stringing bar similar to the bars **326** of FIG. **8** could be provided at the scoop of head **304**, for example, attaching both ends of the bar to two different locations on the scoop.

Examples of suitable materials for a lacrosse head according to the present invention include nylon, composite materials, elastomers, metal, urethane, polycarbonate, polyethylene, polypropylene, polyketone, polybutylene terephthalate, acetals (e.g., Delrin™ by DuPont), acrylonitrile-butadiene-styrene (ABS), acrylic, acrylic-styrene-acrylonitrile (ASA), alcryn (partially crosslinked halogenated polyolefin alloy), styrene-butadiene-styrene, styrene-ethylene-butylene styrene, thermoplastic olefinic (TPO), thermoplastic vulcanizate (TPV), ethylene-propylene rubber (EPDM), and polyvinyl chloride (PVC).

The foregoing disclosure of the preferred embodiments of the present invention has been presented for purposes of illustration and description. It is not intended to be exhaustive or to limit the invention to the precise forms disclosed. Many variations and modifications of the embodiments described herein will be apparent to one of ordinary skill in the art in light of the above disclosure. The scope of the invention is to be defined only by the claims, and by their equivalents.

Further, in describing representative embodiments of the present invention, the specification may have presented the method and/or process of the present invention as a particular

13

sequence of steps. However, to the extent that the method or process does not rely on the particular order of steps set forth herein, the method or process should not be limited to the particular sequence of steps described. As one of ordinary skill in the art would appreciate, other sequences of steps may be possible. Therefore, the particular order of the steps set forth in the specification should not be construed as limitations on the claims. In addition, the claims directed to the method and/or process of the present invention should not be limited to the performance of their steps in the order written, and one skilled in the art can readily appreciate that the sequences may be varied and still remain within the spirit and scope of the present invention.

What is claimed is:

1. A lacrosse head comprising:
 - a stop member;
 - a first sidewall extending from the stop member;
 - a second sidewall extending from the stop member;
 - a scoop connecting the first sidewall and the second sidewall opposite to the stop member, wherein the stop member, the first and second sidewalls, and the scoop form a frame that encloses an interior of the lacrosse head;
 - a first flexible stringing member integrally formed with the frame and extending along the first sidewall;
 - a second flexible stringing member integrally formed with the frame and extending along the second sidewall, wherein, at rest, the first flexible stringing member is separated from the second flexible stringing member by a non-flexed distance; and
 - a pocket attached to the first flexible stringing member and the second flexible stringing member,
 - wherein, in response to a force applied to the pocket in a direction from a ball receiving side of the lacrosse head to a ball retaining side of the lacrosse head, the first and second flexible stringing members move toward each other in a direction toward the interior of the lacrosse head such that the first and second flexible stringing members are separated by a flexed distance that is less than the non-flexed distance, thereby narrowing the pocket wherein the first flexible stringing member comprises a flexible stringing rail having a first end and a second end, wherein the first end is connected to the frame and the second end is connected to the frame, and wherein the flexible stringing rail is separated from the frame by a slot.
2. The lacrosse head of claim 1, wherein the first flexible stringing member is attached to the stop member and the scoop and disposed inwardly of the first sidewall, and wherein the second flexible stringing member is attached to the stop member and the scoop and disposed inwardly of the second sidewall.
3. The lacrosse head of claim 1, wherein the first end of the flexible stringing rail is connected to a first portion of the first sidewall proximate to the stop member and wherein the second end of the flexible stringing rail is connected to a second portion of the first sidewall proximate to the scoop.
4. The lacrosse head of claim 1, wherein the first end of the flexible stringing rail is connected to a first portion of the scoop proximate to the first sidewall and wherein the second end of the flexible stringing rail is connected to a second portion of the scoop proximate to the second sidewall.

14

5. The lacrosse head of claim 1, wherein the slot has a teardrop shape at the first end and the second end of the flexible stringing rail to minimize stress points during flexure of the flexible stringing rail.

6. The lacrosse head of claim 1, wherein the slot is formed between the flexible stringing rail and the scoop, and wherein the scoop and the flexible stringing rail overlap each other such that no through passage is visible through the slot when viewed in a direction facing the ball receiving side of the head, and wherein the slot tapers inwardly toward the interior of the lacrosse head.

7. The lacrosse head of claim 1, wherein the first flexible stringing member defines a first hole and the first sidewall defines a second hole,

15 wherein the first hole and the second hole are aligned, wherein the first hole and the second hole are separated by a gap, and wherein the lacrosse head further comprises an attachment member threaded through the first hole and the second hole to selectively adjust the size of the gap.

8. A lacrosse head comprising:

- a stop member;
- a first sidewall extending from the stop member;
- a second sidewall extending from the stop member;
- 25 a scoop connecting the first sidewall and the second sidewall opposite to the stop member, wherein the stop member, the first and second sidewalls, and the scoop form a frame that encloses an interior of the lacrosse head;

- a first flexible pocket member connected to the frame;
- a second flexible pocket member connected to the frame, wherein each of the first flexible pocket member and the second flexible pocket member is disposed inwardly of both the first sidewall and the second sidewall, wherein the first flexible pocket member and the second flexible pocket member extend in a direction generally parallel to a shaft axis of the lacrosse head when viewed in a direction facing a ball receiving side of the lacrosse head,

- 40 wherein the first flexible pocket member and the second flexible pocket member are disposed approximately equal distances from the shaft axis on opposite sides of the shaft axis to form a ball guide track, and

- 45 wherein the first flexible pocket member and the second flexible pocket member are configured to flex more in a first direction generally from the ball receiving side of the lacrosse head toward the ball retaining side of the lacrosse head than in a second direction generally from the ball retaining side of the lacrosse head toward the ball receiving side of the lacrosse head such that the first flexible pocket member and the second flexible pocket member flex more when a ball is caught in the lacrosse head than when a ball is thrown from the lacrosse head.

9. The lacrosse head of claim 8, wherein the first flexible pocket member and the second flexible pocket member each comprises a string longitudinally threaded therein.

10. The lacrosse head of claim 9, further comprising a string laterally threaded through the first flexible pocket member and the second flexible pocket member.

60 11. The lacrosse head of claim 8, wherein a side of the first flexible pocket member facing in the second direction and a side of the second flexible pocket member facing in the second direction have a textured surface to enhance ball grip.

* * * * *