



US00D948639S

(12) **United States Design Patent**
Ach et al.

(10) **Patent No.:** **US D948,639 S**
(45) **Date of Patent:** **** Apr. 12, 2022**

(54) **REHABILITATION DEVICE**
(71) Applicant: **ROM TECHNOLOGIES, INC.**,
Brookfield, CT (US)
(72) Inventors: **Samuel Marcus Ach**, Portland, OR
(US); **Doug Golenz**, Littleton, CO (US)

1,784,230 A 12/1930 Freeman
3,081,645 A 3/1963 Bergfors
3,100,640 A 8/1963 Weitzel
3,137,014 A 6/1964 Meucci
3,143,316 A 8/1964 Shapiro
3,713,438 A 1/1973 Knutsen
3,744,480 A 7/1973 Gause et al.
(Continued)

(73) Assignee: **ROM TECHNOLOGIES, INC.**,
Brookfield, CT (US)

FOREIGN PATENT DOCUMENTS

(**) Term: **15 Years**

JP 6573739 B1 9/2019
KR 20160093990 A 8/2016
(Continued)

(21) Appl. No.: **29/764,219**

(22) Filed: **Dec. 29, 2020**

OTHER PUBLICATIONS

Related U.S. Application Data

HCI Fitness PhysioTrainer Upper Body Ergonometer, <https://www.amazon.com/HCI-Fitness-PhysioTrainer-Upper-Ergonometer/dp/B001P5GUGM>.

(62) Division of application No. 29/717,404, filed on Dec. 17, 2019, now Pat. No. Des. 907,143.

(Continued)

(51) **LOC (13) Cl.** **21-02**

Primary Examiner — Khawaja Anwar

(52) **U.S. Cl.**

Assistant Examiner — Julice Seung Eun Oum

USPC **D21/663**

(74) *Attorney, Agent, or Firm* — Dickinson Wright, PLLC; Stephen A. Mason; Michael E. Noe, Jr.

(58) **Field of Classification Search**

USPC D21/419, 432, 435, 667, 666, 668, 690,
D21/676, 691, 662, 675, 686, 694, 663,
D21/697; D6/552; D12/108, 109, 111,
D12/112, 113, 124, 178, 345

(57)

CLAIM

See application file for complete search history.

The ornamental design for a rehabilitation device, substantially as shown and described.

(56) **References Cited**

DESCRIPTION

U.S. PATENT DOCUMENTS

59,915 A 11/1866 Lallement
363,522 A 5/1887 Knous
446,671 A 2/1891 Elliott
610,157 A 8/1898 Campbell
631,276 A 8/1899 Bulova
823,712 A 6/1906 Uhlmann
1,149,029 A 8/1915 Clark
1,227,743 A 5/1917 Burgedorfp

FIG. 1 is a top isometric view of a rehabilitation device. FIG. 2 is a front view of the device of FIG. 1. FIG. 3 is a rear view of the device of FIG. 1. FIG. 4 is right side view of the device of FIG. 1. FIG. 5 is a left side view of the device of FIG. 1; and, FIG. 6 is a top view of the device of FIG. 1. The dashed lines form no part of the claimed design.

1 Claim, 6 Drawing Sheets

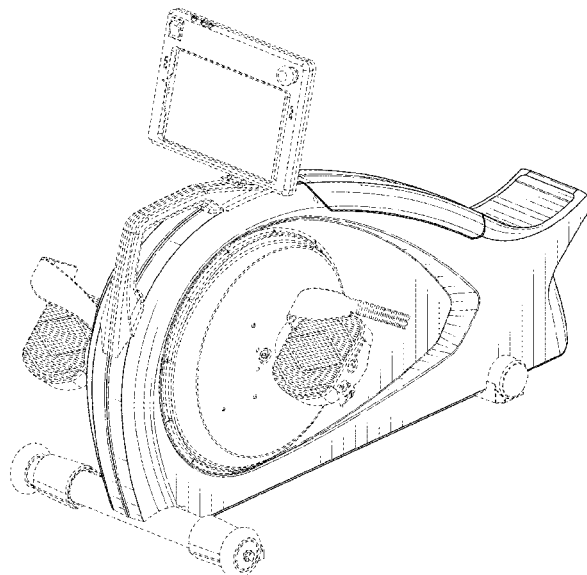

(56)

References Cited

U.S. PATENT DOCUMENTS

3,888,136	A	6/1975	Lapeyre	8,672,812	B2	3/2014	Dugan
4,079,957	A	3/1978	Bleuse	8,751,264	B2	6/2014	Beraja et al.
4,408,613	A	10/1983	Relyea	8,784,273	B2	7/2014	Dugan
4,436,097	A	3/1984	Cunningham	8,823,448	B1	9/2014	Shen
4,446,753	A	5/1984	Nagano	8,979,711	B2	3/2015	Dugan
4,477,072	A	10/1984	DeCloux	D744,050	S	11/2015	Colburn
4,499,900	A	2/1985	Petrofsky et al.	9,272,185	B2	3/2016	Dugan
4,509,742	A	4/1985	Cones	9,311,789	B1	4/2016	Gwin
4,606,241	A	8/1986	Fredriksson	9,409,054	B2	8/2016	Dugan
4,611,807	A	9/1986	Castillo	9,480,873	B2	11/2016	Chuang
4,616,823	A	10/1986	Vang	9,566,472	B2	2/2017	Dugan
4,648,287	A	3/1987	Preskitt	D793,494	S *	8/2017	Mansfield D21/668
4,673,178	A	6/1987	Dwight	D794,142	S	8/2017	Zhou
4,824,104	A	4/1989	Bloch	9,914,053	B2	3/2018	Dugan
4,850,245	A	7/1989	Feamster et al.	9,937,382	B2	4/2018	Dugan
4,858,942	A	8/1989	Rodriguez	9,939,784	B1	4/2018	Berardinelli
4,869,497	A	9/1989	Stewart et al.	10,155,134	B2	12/2018	Dugan
4,915,374	A	4/1990	Watkins	10,576,331	B2	3/2020	Kuo
4,930,768	A	6/1990	Lapcevic	11,040,238	B2 *	6/2021	Colburn A63B 21/225
4,961,570	A	10/1990	Chang	2002/0160883	A1	10/2002	Dugan
5,161,430	A	11/1992	Febey	2003/0036683	A1	2/2003	Kehr et al.
5,202,794	A	4/1993	Schnee et al.	2003/0083596	A1	5/2003	Kramer et al.
5,247,853	A	9/1993	Dalebout	2003/0092536	A1	5/2003	Romanelli et al.
5,282,748	A	2/1994	Little	2003/0109814	A1	6/2003	Rummerfield
5,316,532	A	5/1994	Butler	2004/0106502	A1	6/2004	Sher
5,324,241	A	6/1994	Artigues et al.	2004/0172093	A1	9/2004	Rummerfield
5,336,147	A	8/1994	Sweeney, III	2004/0194572	A1	10/2004	Kim
5,338,272	A	8/1994	Sweeney, III	2005/0020411	A1	1/2005	Andrews
5,361,649	A	11/1994	Slocum, Jr.	2005/0049122	A1	3/2005	Vallone et al.
D353,421	S *	12/1994	Gallivan D21/667	2005/0085346	A1	4/2005	Johnson
5,458,022	A	10/1995	Mattfeld et al.	2005/0085353	A1	4/2005	Johnson
5,487,713	A	1/1996	Butler	2005/0274220	A1	12/2005	Reboullet
5,566,589	A	10/1996	Buck	2006/0003871	A1	1/2006	Houghton
5,580,338	A	12/1996	Scelta et al.	2006/0064329	A1	3/2006	Abolfathi et al.
5,676,349	A	10/1997	Wilson	2006/0247095	A1	11/2006	Rummerfield
5,685,804	A	11/1997	Whan-Tong et al.	2008/0161166	A1	7/2008	Lo
5,860,941	A	1/1999	Saringer et al.	2009/0011907	A1	1/2009	Radow et al.
5,950,813	A	9/1999	Hoskins et al.	2009/0070138	A1	3/2009	Langheier et al.
6,053,847	A	4/2000	Stearns et al.	2009/0211395	A1	8/2009	Mul ³ e
6,077,201	A	6/2000	Cheng	2010/0248905	A1	9/2010	Lu
6,102,834	A	8/2000	Chen	2010/0268304	A1	10/2010	Matos
6,155,958	A	12/2000	Goldberg	2011/0172059	A1	7/2011	Watterson et al.
6,182,029	B1	1/2001	Friedman	2011/0218814	A1	9/2011	Coats
D438,580	S	3/2001	Shaw	2011/0275483	A1	11/2011	Dugan
6,253,638	B1	7/2001	Bermudez	2012/0065987	A1	3/2012	Farooq et al.
D450,100	S	11/2001	Hsu	2012/0167709	A1	7/2012	Chen et al.
D450,101	S	11/2001	Hsu	2012/0190502	A1	7/2012	Paulus et al.
D451,972	S	12/2001	Easley	2012/0310667	A1	12/2012	Altman et al.
D452,285	S	12/2001	Easley	2013/0123667	A1	5/2013	Komatireddy et al.
D454,605	S *	3/2002	Lee D21/694	2013/0296987	A1	11/2013	Rogers et al.
6,371,891	B1	4/2002	Speas	2014/0006042	A1	1/2014	Keefe et al.
D459,776	S *	7/2002	Lee D21/697	2014/0011640	A1	1/2014	Dugan
6,430,436	B1	8/2002	Richter	2014/0155129	A1	6/2014	Dugan
6,474,193	B1	11/2002	Farney	2014/0188009	A1	7/2014	Lange et al.
6,491,649	B1	12/2002	Ombrellaro	2014/0194250	A1	7/2014	Reich et al.
6,543,309	B2	4/2003	Heim	2014/0257837	A1	9/2014	Walker et al.
D475,424	S *	6/2003	Lee D21/694	2014/0309083	A1	10/2014	Dugan
6,589,139	B1	7/2003	Butterworth	2014/0322686	A1	10/2014	Kang
D482,416	S *	11/2003	Yang D21/663	2015/0088544	A1	3/2015	Goldberg
6,640,662	B1	11/2003	Baxter	2015/0151162	A1	6/2015	Dugan
D484,931	S *	1/2004	Tsai D21/694	2015/0161331	A1	6/2015	Oleynik
6,820,517	B1	11/2004	Farney	2015/0339442	A1	11/2015	Oleynik
6,865,969	B2	3/2005	Stevens	2016/0023081	A1	1/2016	Popa-Simil
6,895,834	B1	5/2005	Baatz	2016/0140319	A1	5/2016	Stark et al.
7,169,085	B1	1/2007	Killin et al.	2016/0151670	A1	6/2016	Dugan
7,204,788	B2	4/2007	Andrews	2016/0166881	A1	6/2016	Ridgel et al.
7,209,886	B2	4/2007	Kimmel	2016/0275259	A1	9/2016	Nolan et al.
7,226,394	B2	6/2007	Johnson	2016/0302721	A1	10/2016	Wiedenhofer et al.
7,406,003	B2	7/2008	Burkhardt et al.	2016/0317869	A1	11/2016	Dugan
D575,836	S *	8/2008	Hsiao D21/668	2017/0004260	A1	1/2017	Moturu et al.
7,594,879	B2	9/2009	Johnson	2017/0014671	A1 *	1/2017	Burns, Sr. A63B 22/0046
7,726,034	B2	6/2010	Wixey	2017/0106242	A1	4/2017	Dugan
8,506,458	B2	8/2013	Dugan	2017/0113092	A1	4/2017	Johnson
8,556,778	B1	10/2013	Dugan	2017/0143261	A1	5/2017	Wiedenhofer et al.
8,607,465	B1	12/2013	Edwards	2017/0147789	A1	5/2017	Wiedenhofer et al.
				2017/0181698	A1	6/2017	Wiedenhofer et al.
				2017/0243028	A1	8/2017	LaFever et al.
				2017/0265800	A1	9/2017	Auchinleck et al.
				2017/0278209	A1	9/2017	Olsen et al.

(56)

References Cited

U.S. PATENT DOCUMENTS

2017/0300654 A1 10/2017 Stein et al.
 2017/0329917 A1 11/2017 McRaith et al.
 2017/0344726 A1 11/2017 Duffy et al.
 2017/0360586 A1 12/2017 Dempers et al.
 2018/0052962 A1 2/2018 Kojik et al.
 2018/0071565 A1 3/2018 Gomberg et al.
 2018/0071566 A1 3/2018 Gomberg et al.
 2018/0071569 A1 3/2018 Gomberg et al.
 2018/0071570 A1 3/2018 Gomberg et al.
 2018/0071571 A1 3/2018 Gomberg et al.
 2018/0071572 A1 3/2018 Gomberg et al.
 2018/0102190 A1 4/2018 Hogue et al.
 2018/0200577 A1 7/2018 Dugan
 2018/0240552 A1 8/2018 Tuyl et al.
 2018/0271432 A1 9/2018 Auchinleck et al.
 2018/0330824 A1 11/2018 Athey et al.
 2019/0019578 A1 1/2019 Vaccaro
 2019/0066832 A1 2/2019 Kang et al.
 2019/0076701 A1 3/2019 Dugan
 2019/0304584 A1 10/2019 Savolainen
 2019/0307983 A1 10/2019 Goldman
 2019/0354632 A1 11/2019 Mital et al.

2020/0005928 A1 1/2020 Daniel
 2020/0051446 A1 2/2020 Rubinstein et al.
 2020/0093418 A1 3/2020 Kluger et al.
 2020/0143922 A1 5/2020 Chekroud et al.
 2020/0151595 A1 5/2020 Jayalath et al.
 2020/0152339 A1 5/2020 Pulitzer et al.
 2020/0160198 A1 5/2020 Reeves et al.
 2020/0176098 A1 6/2020 Lucas et al.
 2020/0289878 A1* 9/2020 Arn A63B 22/0605
 2020/0289881 A1 9/2020 Hacking et al.
 2020/0289889 A1* 9/2020 Hacking A61B 5/681
 2020/0293712 A1 9/2020 Potts et al.

FOREIGN PATENT DOCUMENTS

WO 2021021447 A1 2/2021
 WO 2021138620 A1 7/2021

OTHER PUBLICATIONS

HCI Fitness PhysioTrainer PRO Electronically Controlled UBE,
<https://www.amazon.com/HCI-Fitness-PhysioTrainer-Electronically-Controlled/dp/B0759YMW78>.

* cited by examiner

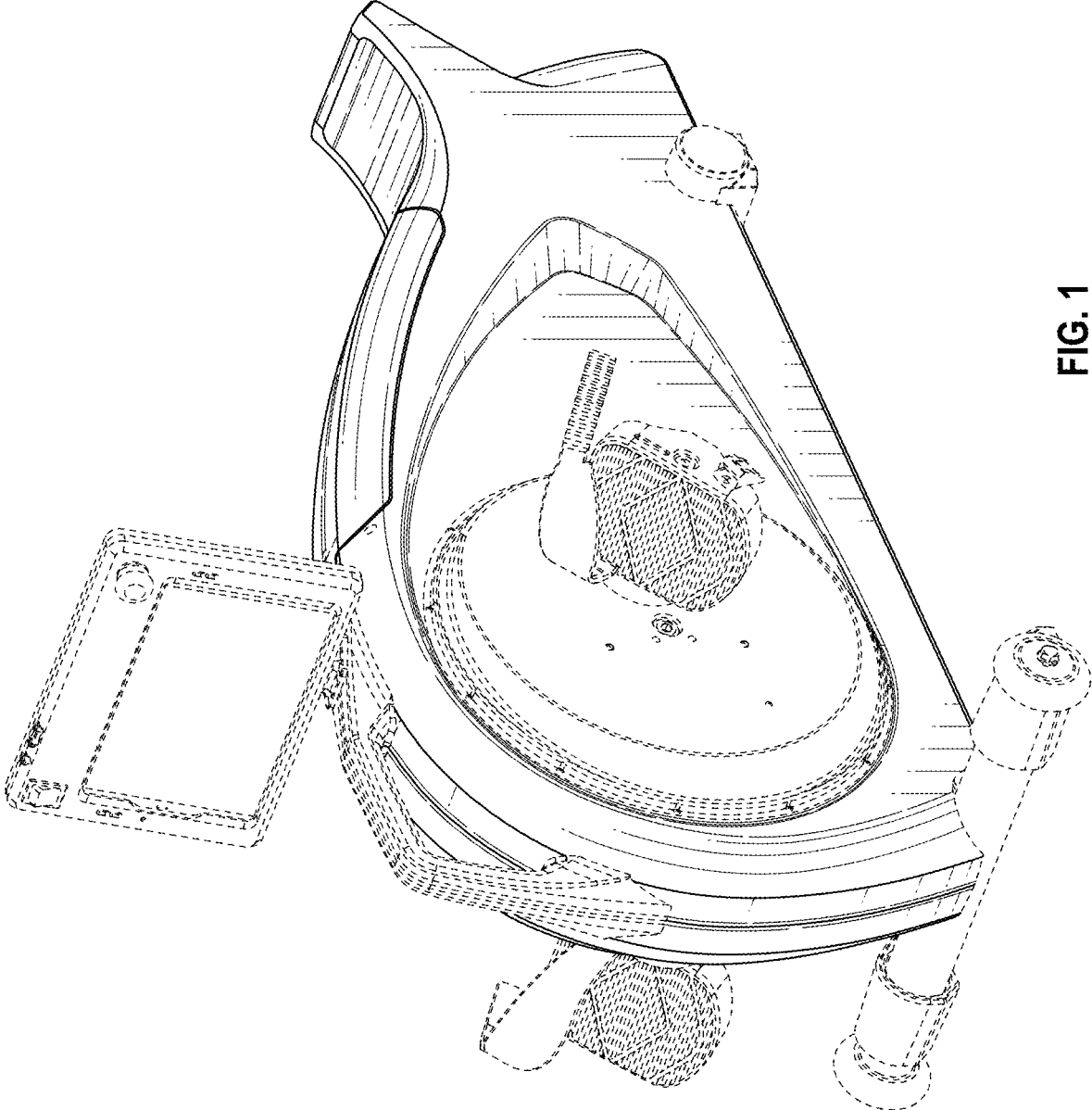

FIG. 1

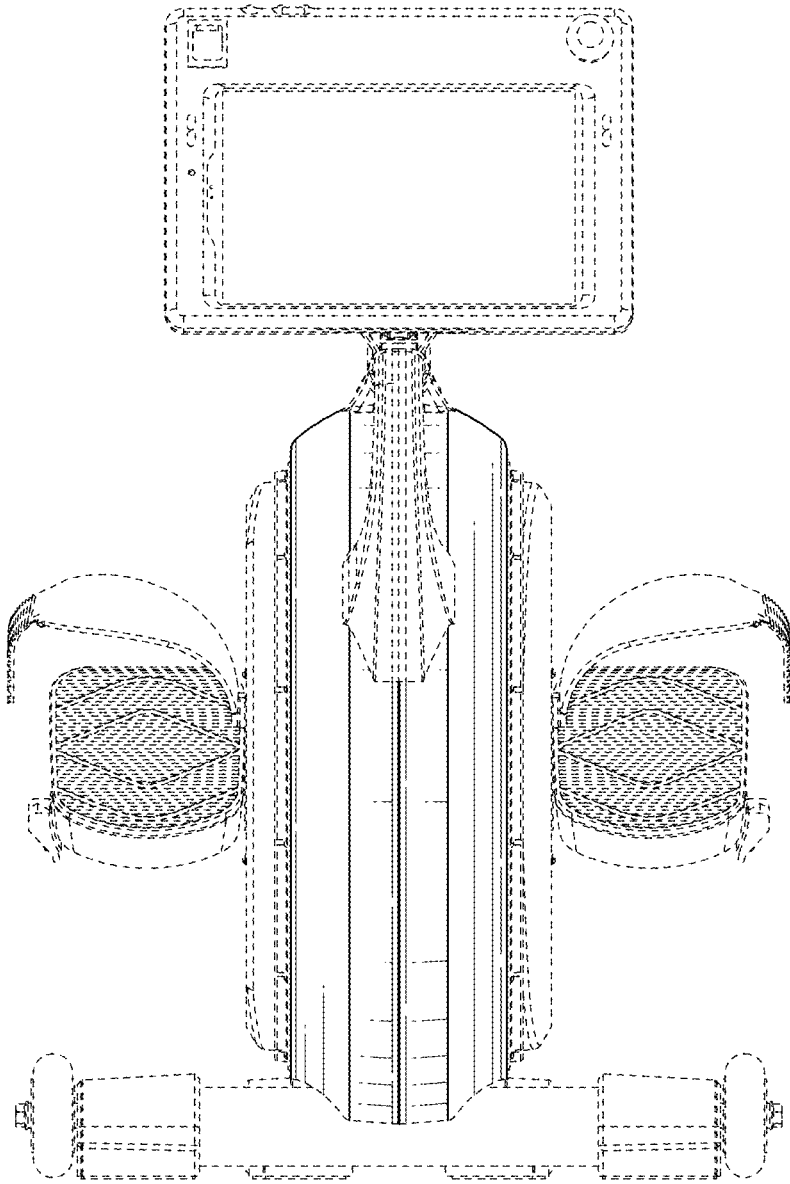

FIG. 2

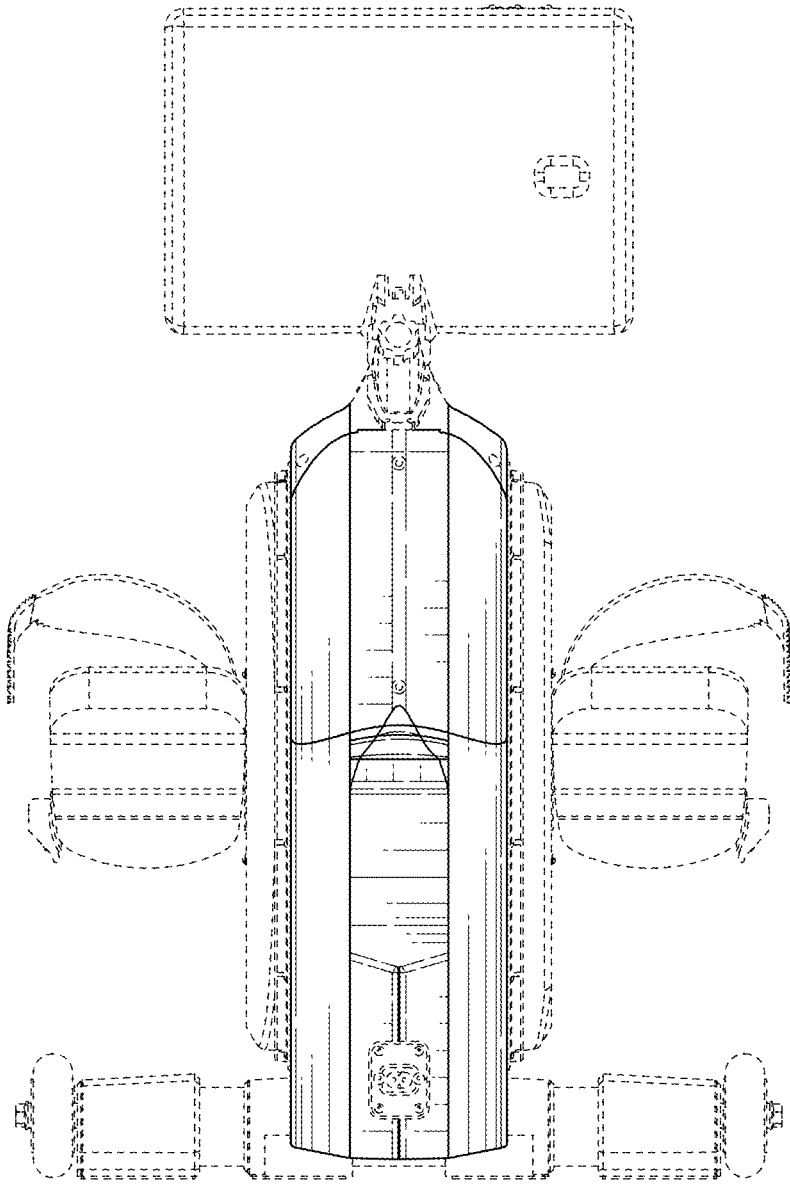

FIG. 3

FIG. 4

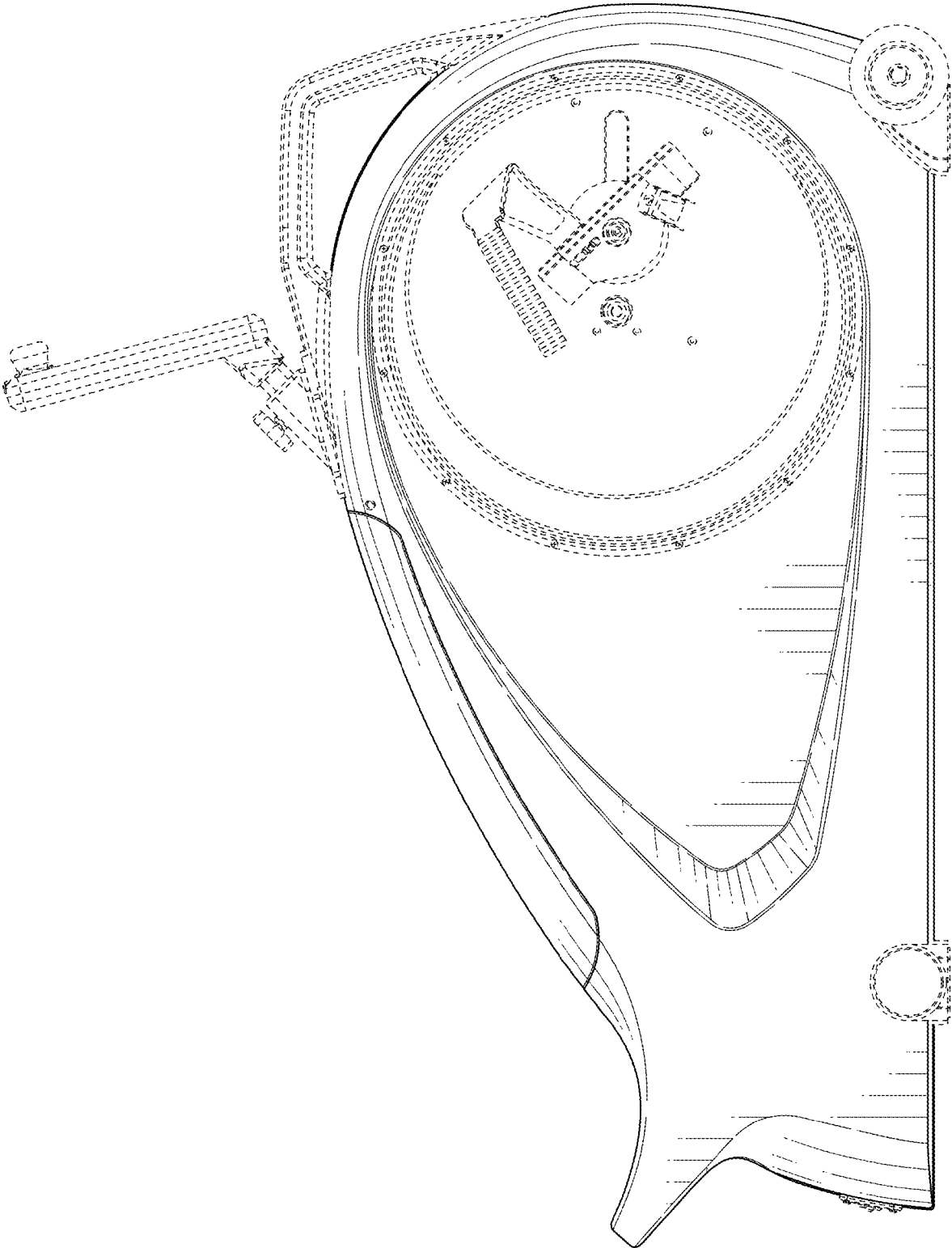
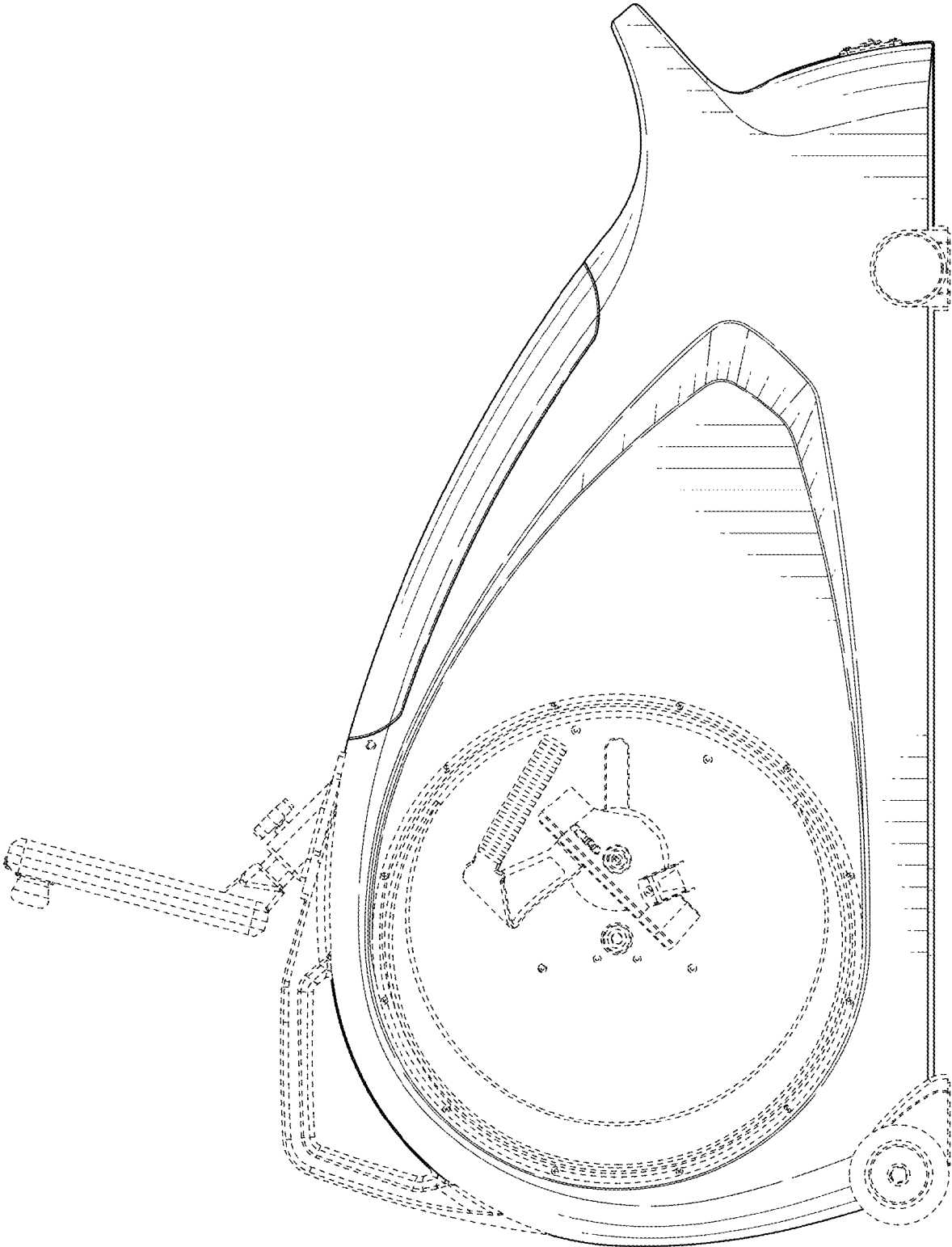

FIG. 5



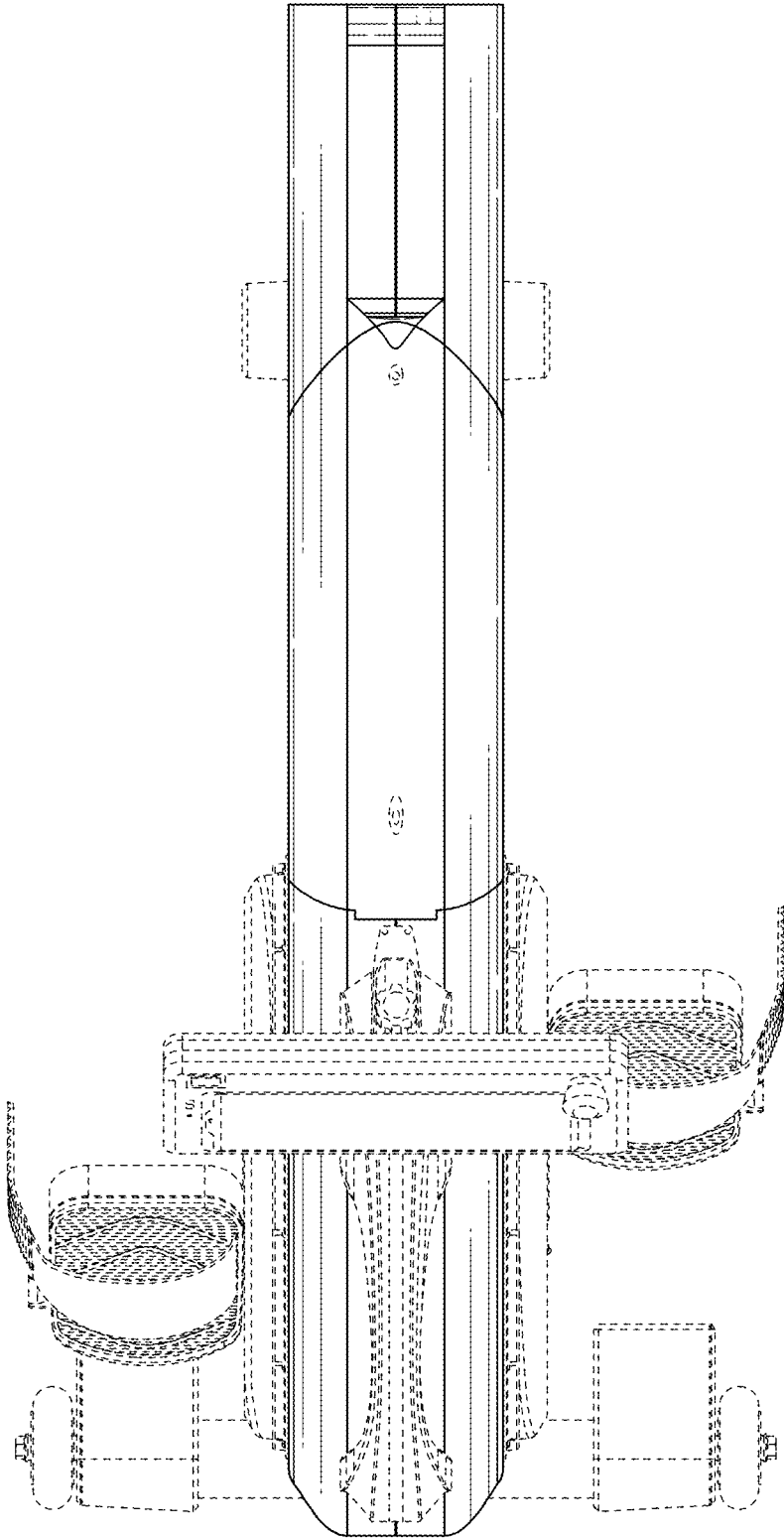

FIG. 6