

(19) World Intellectual Property Organization  
International Bureau



(43) International Publication Date  
1 March 2007 (01.03.2007)

PCT

(10) International Publication Number  
**WO 2007/025019 A2**

(51) International Patent Classification:  
A61M 5/178 (2006.01)

(74) Agent: GRAFE, V., Gerald; P.O. Box 2689, Corrales, NM 87048 (US).

(21) International Application Number:  
PCT/US2006/033033

(81) Designated States (unless otherwise indicated, for every kind of national protection available): AE, AG, AL, AM, AT, AU, AZ, BA, BB, BG, BR, BW, BY, BZ, CA, CH, CN, CO, CR, CU, CZ, DE, DK, DM, DZ, EC, EE, EG, ES, FI, GB, GD, GE, GH, GM, HN, HR, HU, ID, IL, IN, IS, JP, KE, KG, KM, KN, KP, KR, KZ, LA, LC, LK, LR, LS, LT, LU, LV, LY, MA, MD, MG, MK, MN, MW, MX, MY, MZ, NA, NG, NI, NO, NZ, OM, PG, PH, PL, PT, RO, RS, RU, SC, SD, SE, SG, SK, SL, SM, SV, SY, TJ, TM, TN, TR, TT, TZ, UA, UG, US, UZ, VC, VN, ZA, ZM, ZW.

(22) International Filing Date: 24 August 2006 (24.08.2006)

(25) Filing Language: English

(26) Publication Language: English

(30) Priority Data:  
60/711,279 24 August 2005 (24.08.2005) US  
11/316,775 23 December 2005 (23.12.2005) US

(84) Designated States (unless otherwise indicated, for every kind of regional protection available): ARIPO (BW, GH, GM, KE, LS, MW, MZ, NA, SD, SL, SZ, TZ, UG, ZM, ZW), Eurasian (AM, AZ, BY, KG, KZ, MD, RU, TJ, TM), European (AT, BE, BG, CH, CY, CZ, DE, DK, EE, ES, FI, FR, GB, GR, HU, IE, IS, IT, LT, LU, LV, MC, NL, PL, PT, RO, SE, SI, SK, TR), OAPI (BF, BJ, CF, CG, CI, CM, GA, GN, GQ, GW, ML, MR, NE, SN, TD, TG).

(71) Applicants and

(72) Inventors: SIBBITT, Wilmer, L. [US/US]; 338 Amhart Drive NE, Albuquerque, NM 87106 (US). SIBBITT, Randy, R. [US/US]; 71 Clover View Drive, Helena, MT 59601 (US).

[Continued on next page]

(54) Title: VASCULAR CLOSURE METHODS AND APPARATUSES

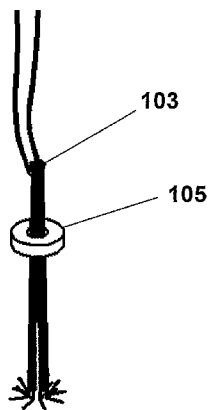
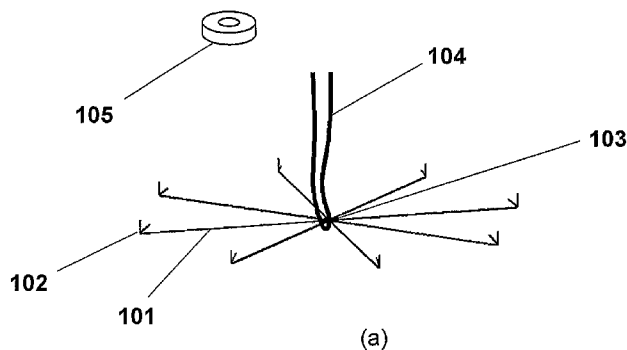

(57) Abstract: A vascular closure device comprised of a sheath-delivered expandable, umbrella-like device with structural radial members with terminal and non-terminal hooks that engage the vessel wall. Unlike other vascular closure umbrella-type devices that effect closure by opening of the umbrella to cover an opening, the present invention effects closure of the aperture with closure of the umbrella. The closure can be maintained by a retainer lock that slides down the members, causing contraction, bringing the members into a compressed configuration (e.g., a parallel orientation of linear members) and the wound edges together, permitting immediate vascular closure and healing of the blood vessel. The device can be delivered and recovered by an intravascular sheath.

WO 2007/025019 A2



**Declaration under Rule 4.17:**

— *of inventorship (Rule 4.17(iv))*

**Published:**

— *without international search report and to be republished upon receipt of that report*

*For two-letter codes and other abbreviations, refer to the "Guidance Notes on Codes and Abbreviations" appearing at the beginning of each regular issue of the PCT Gazette.*

## Vascular Closure Methods and Apparatuses

### Technical Field

[0001] The present invention relates to methods and apparatuses for closing punctures and apertures in human and animal tissue and to methods and apparatuses for inserting such an apparatus into such tissue to perform such closure functions.

### Background Art

[0002] This application is related to U.S. provisional application 60/711,279, filed 8/25/2005, and U.S. utility application 11/316,775, filed 12/23/2005, each of which is incorporated herein by reference. During angiography and related procedures, catheters are inserted through an incision or puncture in the skin and underlying tissues to access an artery or vein, typically in the groin, neck, or subclavian areas of a patient. The catheter can be inserted through a puncture in the blood vessel and guided to the desired site to perform interventional procedures such as angiography, angioplasty, plaque removal, and infusion of a therapeutic substance. After the procedure is completed and the catheter is removed from the patient, the access hole must be closed to prevent massive hemorrhage. This is conventionally achieved by applying pressure over the blood vessel manually and then by applying a pressure bandage, compressive weight, or clamp device. With conventional methods, the rate of post-puncture hemorrhage is high, which causes considerable complications. This complication is exacerbated by the concomitant use of anticoagulant medications such as heparin or warfarin and by antiplatelet drugs, which are commonly used to treat vascular disease.

[0003] Sutures have been used to close access puncture wounds in blood vessels. US05613974 describes a device and method for applying sutures to a vascular puncture. US2004/0093027A1 describes barbed suture-like material that apposes the puncture site. US 2005/0121042 A1 describes a device and method for applying suture to a vascular puncture. Difficulties with these methods include the large number of steps necessary to deploy the needles, capture the suture, withdraw the suture, tie the knot, and cut the suture. In addition, the hole in the blood vessel is often widened by insertion of the instrument, and the suture remains intravascularly on the endothelial surface, and thus can be a nidus for thrombus or intravascular mural hyperplasia with later spontaneous and catastrophic closure of the vessel.

[0004] Extravascular plugs have also been proposed for closure of vascular punctures. US05254105 and US05330445 describe an extravascular plug which is slid down the external surface of the catheter or introducer and is placed into the puncture site in this manner. US05643318 relates to a similar device that has its own vessel locator device. US22022822A1 and US2004/0158287A1 describe an extravascular plug that is delivered with a specialized system. US24215232A1 describes an extravascular plug with an intravascular anchor set with a sheath with a detection port. US2005/0085855A1 describes an extravascular collagen plug, held in place with an intravascular anchor, and a device that locks over a piece of suture. US05906631 describes a plug made of hydrophilic material. US06126675 describes an intravascular anchor and a bioabsorbable extravascular plug. US06623509 describes a bioabsorbable plug. US06296657 and US06743195 describe an inflatable balloon that puts pressure on the puncture site. US06569185 describes an injectable vascular plug. US06663655 describes a plug that screws in the puncture tract. US2004/0143290 A1 describes a

combination of an intraluminal balloon and injectable sealant. Disadvantages to these methods are related to the high likelihood of thrombosis associated with the intravascular plug or anchor, and the presence of collagen or other bioabsorbable materials which cause inflammation, activate the clotting cascade, and increase the likelihood of thrombosis, which, in an arterial system, is catastrophic.

[0005] Vascular patches have also been used for repairing blood vessels, but usually only for large areas of damage. US05100422 describes a vascular patch that is sutured to the external surface of the damaged blood vessel. US05100422 describes a vascular patch achieved by instilled adhesives and the device for doing such. These are generally impractical for catheter-based methods. US06248124 and US05507744 describe devices and methods that use electrocautery for sealing vascular punctures. This also requires a complicated device, and perforation and thrombosis are very real possibilities.

[0006] Vascular clips or staples delivered through a catheter device have also been proposed. These devices have penetrating members that bring the edges of the tissue together. US06695867 describes a clip or staple that is delivered by a specialized device. US06749622 describes a number of different clips with sharpened barbs or ends that include both intra- and extravascular portions, made of metal with memory characteristics. US05861005 describes an arterial staple that is delivered with a specialized device. US05919207 describes a stapling system based on long hooked wires that appose the surfaces, with a small staple gun to close the lesion. US06022372 describes a similar staple gun. US06296657, US06663655, and US06749621 describe a clip that is external to the vessel, but clips the two sides of the puncture together, and a device for achieving such. US 5782861 and US 5964782 describe clip devices composed of two or more prongs or hooks that, depending on the direction of the prongs, can clip together the puncture site from the intra- or extra-vascular position, through the use of a collar which forces the prongs together or other mechanisms. These clip devices are composed of thick semi-rigid material, and can be placed only with a specialized instruments, and because of the rigidity have great potential to injure or cut the blood vessel. Disadvantages of these clip devices in general include difficulty in retrieving the device if misplaced, excessive manipulation required, the thickness of the clip material which tends to cut or shear the blood vessel, the large forces that must be used to curve the staples and fix the clips, the increased possibility of tearing the blood vessel, and the general lack of control of the forces being applied to the blood vessel.

[0007] Accordingly, there is a need for methods and apparatuses that are suitable for closure of vascular punctures or other openings, and that do not suffer from the drawbacks of conventional approaches.

#### **Disclosure of Invention**

[0008] The present invention provides methods and apparatuses that are suitable for closure of vascular punctures or other openings, and that do not suffer from the drawbacks of conventional approaches.

[0009] The present invention comprises a tissue closure device, comprising a plurality of tissue engagement elements, mounted with each other such that in a first compressed configuration the tissue engagement elements can pass through a tissue opening to be closed, and such that in a second compressed configuration the tissue engagement elements bring the edges of the opening into apposition, and such that in an expanded configuration the tissue engagement elements span the opening, wherein the tissue engagement elements engage the tissue in the compressed configuration and in the expanded configuration.

[0010] The present invention also comprises methods for closing tissue openings, comprising passing a device while in the first compressed condition through a sheath that penetrates the proximal surface of the tissue; expelling the device from the sheath into space beyond the proximal surface of the tissue such that the device assumes the expanded configuration; c) manipulating the device such that the tissue engagement elements engage the tissue; d) causing the device to assume the second compressed configuration, bringing the edges of the opening into apposition.

[0011] The present invention can provide a catheter-delivered umbrella-like device comprising fine, strong, flexible material that after delivery expands in a blood vessel so that the individual members extend beyond the catheter edges and/or puncture dimensions. The device can be viewed as analogous in structure and design as contemporary expandable vascular filters and closure umbrellas, although its purpose and function is completely different. As the catheter is withdrawn, the device is pulled against the interior of the blood vessel and the hooks or grasping devices on the ends of the members seize the interior of the vessel wall. Because of the very fine and flexible nature of the members and their multiplicity, there is minimal shear force applied to the blood vessel. While pulling on the retaining suture to keep the device against the blood vessel, a retaining lock is then advanced distally starting at the proximal portion of the members, which causes the members to first angle the device into a conical shape and then force the individual members together in a linear parallel direction, which because the members are engaged with the vessel wall, brings the edges of the punctured tissue together into apposition. The retainer lock is then locked onto the parallel members and can keep tension on the wound externally, and can prevent intravascular migration of the device. If there is no blood leakage through the closure and the device is properly positioned and stable, then the guidewire can be removed and the retaining suture or string loop cut, resulting in complete and rapid closure, which can then heal.

[0012] Since this device brings the puncture edges together, there is true blood vessel healing with little endothelial disruption, reducing the chances of thrombosis or intimal hyperplasia. The device can be supplied in different diameters (e.g., french) to accommodate different sizes of catheters and different sizes of puncture holes.

[0013] The present invention can comprise a device with umbrella-like structure, which can be viewed as analogous to the various designs of intravascular filters and aperture seals, which are delivered in a folded or compressed form, and then expanded to their filter shapes. US 4969891 describes a self-expanding removable filter device that is placed with a sheath. US 5634942 and US 5634942 describe a similar device but with two sets of arms which protrude in opposite directions. US 6241746 B1 is a similar version that can be converted to a vascular stent. US 6361546 is a version with a central guidewire lumen. US 6428559 describes a variable-diameter vascular filter system. US 6485501 B1 also describes a filter with a guidewire. US 2003/0208227 describes different construction configurations of a filter. US 2004/0087999 A1 reveals various types of structures to retain the filter in the vessel. US 5709707 describes a typical umbrella-type closure device used to close apertures. Each of the preceding patents and applications are incorporated herein by reference. The present device, analogous to many of the vascular filters and umbrella closure devices noted above, is both expandable like an umbrella and retrievable if it had to be retrieved because of misplacement. Unlike previous umbrella closure devices, the present device engages the tissue in both the expanded and compressed configurations, and

functions by bringing tissue edges into apposition rather than by providing a patch that covers the opening. In addition, although the embodiments shown here generally have linear members, these members, like the structure of the intravascular filters and umbrella-type devices, need not be strictly linear, but can assume a number of complex geometrical shapes and structural patterns.

[0014] The present device, like some contemporary vascular filters, can utilize an expanding material, preferably with memory characteristics, that opens up spontaneously within the blood vessel. The device also, like some contemporary filters, can have tissue hooks or penetrators, in order to seize the vessel wall and stabilize the device. However, unlike an umbrella-style vascular filter, the device uses this opening-closing quality to seize the edges of the puncture site, and close them, resulting in a complete vascular closure. Although the device can be viewed as analogous to some contemporary self-expanding and retractable vascular filters, it is unlike them in that in certain embodiments it has a retaining lock to force the umbrella to reassume its folded state.

#### **Brief Description of Drawings**

[0015] The invention is explained by using embodiment examples and corresponding drawings, which are incorporated into and form part of the specification.

Figure 1(a,b) is a schematic depiction of a vascular closure apposition device according to the present invention.

Figure 2(a,b) is a schematic depiction of a vascular closure apposition device according to the present invention.

Figure 3(a,b) is a schematic depiction of a vascular closure apposition device with a guidewire lumen, according to the present invention.

Figure 4 is a schematic depiction of a vascular closure apposition device according to the present invention.

Figure 5 is a schematic depiction of a vascular closure apposition device according to the present invention.

Figure 6(a,b,c) are schematic depictions of example embodiments of vascular closure apposition devices according to the present invention.

Figure 7(a,b,c,d,e,f) is a schematic illustration of a method of closing a vascular opening according to the present invention.

Figure 8(a,b,c,d) is a schematic depiction of a double-action vascular closure apposition device according to the present invention.

Figure 9(a,b,c) is a schematic depiction of a double-action vascular closure apposition device according to the present invention.

#### **Modes for Carrying Out the Invention, and Industrial Applicability**

[0016] The present invention provides apparatuses and methods for closing a vascular puncture wound or any tissue aperture, for example those resulting from the insertion of a vascular catheter or surgical instrument, trauma or disease. The present invention embraces both apparatus and method aspects of devices for closing a vascular puncture, and the methods for delivering such a device. The present device can be closed in the delivery system (catheter or sheath) and when discharged, be open in the blood vessel. In some embodiments, at least a portion of the device can be formed of a memory metal or

similar material, as is currently done in vascular filters. The stress free state corresponds to the state at which the apparatus has opened in a blood vessel, and the stressed state in the catheter and when a retaining lock is put into position. Example embodiments of tissue closure apposition devices according to the present invention are shown in Figures 1, 2, 3, 4, 5, 6, and 8. The descriptions refer to "vessels" for convenience; the present invention is applicable to facilitate closure of various types of tissue openings.

[0017] Figure 1(a,b) is a lateral view of a vascular closure apposition umbrella. A plurality of members 101 are disposed substantially radially about a central junction 103. Each of the members 101 comprise a tissue hook 102, in the figure a double hook. The central junction 103 is adapted to engage a closed loop of string or suture 104. The hooks 102 engage the tissue, and are brought and maintained together by operation of a retaining lock 105. In Figure 1b, the device is shown in a closed position, where the central junction 103 has passed through the retaining lock 105.

[0018] The vascular closure apposition umbrella of Figure 1(a,b) comprises 2 or more members 101 placed in apposition to each other, shown in the figure as disposed substantially radially. The members 101 in the figure are shown as straight wires, but can be curved or have a wave structure or other design, for example a design to engage a retaining lock. The members are flexible for manipulation in tissue and delivery, yet rigid enough when extended to push the tissue engagement structures against the vessel wall. The tissue engagement structures 102 in this example comprise double hooks, allowing engagement of the tissue in 102 different directions simultaneously. The tissue engagement structures can also comprise multiple hooks, a single hook, or straight engaging devices. The tissue engagement structures can be sharp in order to penetrate in one direction, but not to cut, thus, would generally not have a cutting surface other than the point. The members join in a central junction 103 which can be continuous with each of the members or can be joined to the members by any suitable method. The central junction 103 comprises an eyelet or recovery loop in which initially a closed loop of string or suture 104 engages. The eyelet or recovery loop can be used to recover the device into a catheter in the event of misplacement. A retaining lock 105 can encourage closure of the device, and can also prevent unintended intravascular migration of the device. The retaining lock 105 is shown in the figure as a washer-like device, but can take a number of different shapes and can comprise a number of different materials. For example, the retaining lock 105 can comprise plastic, metal, or composite.

[0019] In operation, the tissue closure apposition umbrella is closed within the catheter or sheath, corresponding to the illustration of Figure 1(b). Once placed within the blood vessel, the umbrella can be opened within the blood vessel, corresponding to the illustration of Figure 1(a), so that the hooks on the members engage the vessel wall. The umbrella can then be closed with the retaining lock. As the umbrella closes with the retaining lock, the hooks hold the edges of the puncture wound and, as they align with each other, bring the puncture wound edges in apposition. Undulations or excrescences on the members or central junction can engage corresponding locking surfaces on the retaining lock. More specific locking devices such as angled dentates, peg and hole, and male-female locking surfaces can also be suitable. A guidewire can go between the members in this particular embodiment without a specific lumen for the guidewire.

[0020] Figure 2(a,b) is a lateral view of a vascular closure apposition double umbrella. A plurality of members 201 are disposed substantially radially about a central junction 203. Each member comprises a

tissue engagement structure 202, shown in the figure as a hook on the end of the member. The central junction can comprise a structure compatible with a string or suture 204 to facilitate deployment and removal. A retaining lock 205, in the figure an umbrella oriented opposite the umbrella formed by members 201, closes the device. Figure 2(b) shows the device with the umbrella formed by members 201 closed, bringing tissue sides in apposition, and the retaining lock 205 open, maintaining the closed position of the umbrella and providing tissue stability on the opposite side of the vessel wall.

[0021] The radial members 201 in Figure 2(a,b) are shown as straight, but can have dentates or other devices compatible with engagement of the retaining lock. The string or suture 204 can be engaged with the central junction 203 to urge the central junction 203 through the retaining lock 205, encouraging the members 201 into apposition. The retaining lock of the device of Figure 2(a,b) comprises another expanding umbrella, but facing the opposite direction. In the figure, the retaining lock umbrella has straight members with hooks on the ends. The retaining lock umbrella can also comprise a variety of configurations, including bent or curved members, members with various hooks or no hooks, web-like structures, and film-like members. This retaining lock comprise more complicated structure members, as examples like many constructions of intravascular stents and filters. The members 201 close and bring the tissue together as in Figure 2(b); the retaining lock can provide for tissue stability in the extravascular tissues. A guidewire in this embodiment can go between the members without a specific lumen for the guidewire.

[0022] Figure 3(a,b) is a lateral view of a vascular closure apposition umbrella with a guidewire lumen. The device comprises members 301 disposed substantially radially about a central junction 303. Each arm 301 comprises a tissue engagement structure 302, in the figure shown as a double hook on the end of the arm 301. The central junction 303 comprises a columnar guidewire lumen with a recovery loop or device for engaging a closed loop of string or suture 304. A retaining lock 305 that closes the device. Figure 3(b) shows the device in a closed position with the retaining lock 305 engaged.

[0023] The embodiment of Figure 3(a,b) comprises a closure apposition umbrella with a guidewire lumen. Inclusion of a guidewire lumen can reduce interference of the guidewire with placement of the umbrella, and allows the guidewire to remain in place in case the seating of the device is not optimal and then the device must be retrieved. The device can be delivered and placed with a guidewire in place. The apposed tissue might close the lumen once the guidewire is withdrawn. If desired, a soft one-way flap valve (not shown) or other structure can be placed in the lumen to occlude any blood flow that might occur when the wire is withdrawn.

[0024] Figure 4 is a lateral view of a vascular closure apposition umbrella comprising members 401 disposed substantially radially about a central junction 403, forming an overall conical shape. The members have tissue engagement structures 402, shown in the figure as hooks at the ends of the members 401. The members also have reversed barbs or feathers 406 to prevent intravascular migration of the device and to maintain the members in a closed state by engaging the tissue, a retaining lock, or both. In operation, the embodiment of Figure 4 is similar to those discussed previously.

[0025] Figure 5 is a lateral view of a vascular closure apposition umbrella. A plurality of members 501 are disposed substantially radially about a central junction 503. The members have tissue engagement structures 502, shown in the figure as a hook at the end of the member 502. The central junction 503 can



have a recovery loop or device, and can engage a string or suture 504 for delivery, placement, and recovery. A retaining lock 505 can engage the members 501, the central junction 503, or both, to encourage the device to and maintain the device in a closed position. A backing or coating 507 can be mounted with the members as a fabric, web, or film. The backing can carry, or be made of, a material that can elute drug to prevent coagulation or to prevent endothelial hyperplasia or can be hemostatic initially, and fill the puncture track later.

[0026] Figure 6(a,b,c) are lateral views of example embodiments of vascular closure apposition devices according to the present invention. In Figure 6(a), members 601 comprise elongated diamond shapes (rather than the straight wires depicted previously), which shape can have advantages in manufacture and in operation. The members 601 have tissue engagement structures 602, in the figure shown as hooks mounted with members at various locations. In Figure 6(b), a device having a reduced number of members 611 is shown. A reduced number of members can provide for a simpler device, which can have manufacturing advantages and can be suitable for certain applications. In Figure 6(c), members 621 comprise a non-linear geometry, and are connected by intermember struts 628. The non-linear geometry and intermember struts can allow specific opening and closing trajectories, and can allow optimization of forces when opening and closing. A wide variety of specific geometries and structures can be suitable with the present invention, as examples including geometries and structures currently used in vascular filters and stents.

[0027] Figure 7(a,b,c,d,e,f) is a schematic illustration of a method of closing a vascular opening according to the present invention. A blood vessel 701 is penetrated by a sheath 702 and a guidewire 703. In Figure 7(a), an apposition device 704, for example as described previously, is in a closed configuration within the sheath, with the loop of string or suture 705 engaged. In Figure 7(b) the device 704 has been extruded from the sheath 702 and is in the expanded configuration within the vessel 701. In Figure 7(c), the device 704 has been positioned against the wall of the vessel 701, seating the tissue engagement structures 706 in the tissue 701. The sheath 702 has been partially removed to facilitate seating of the device. The lock can be pre-seated on the device (not shown) or can be placed on the device after intravascular placement of the device by threading the lock down the guidewire or suture onto a central junction of the device after the device has been positioned in the blood vessel, or positioned by a separate sheath). In Figure 7(d), a retaining lock 707 has been advanced over the members of the apposition device, forcing them into the closed configuration, and bringing the edges of the opening 709 together. If no bleeding occurs, then the guidewire 703 can be removed as shown in Figure 7(e). The loop of string or suture 705 can be cut and removed, leaving the device 704 safely seated and locked with the opening closed, as shown in Figure 7(f).

[0028] Delivery of the device can be done sequentially, or can be done with a dedicated device. For sequential delivery of the device, the following sequence of steps are suitable: 1) the guidewire and sheath are in place, 2) the device is pushed down the sheath, either next to the guidewire or with the guidewire in the lumen of the umbrella; 3) the umbrella is extruded, and then using the thread or suture, pulled tight against the lumen of the vessel; 4) the retaining lock is pushed down the thread and/or guidewire, and is pushed onto the umbrella while applying traction (the sheath can be removed partially at this stage); 5) after the retaining lock is seated, the sheath is observed for bleeding; 6) if there is no

bleeding, then the sheath and guidewire are removed. For a dedicated device, there can be a sheath with the umbrella, a pushing device to push the umbrella out (another sheath), a sheath to push the retaining lock, and a thread/suture to oppose the other sheaths and to retrieve the umbrella if it is misplaced.

[0029] Figure 8 (a,b,c,d) is a lateral view of a double-action vascular closure apposition device. In Figure 8a, the unassembled device is in the closed position. The device comprises a plurality of umbrella members 801 disposed substantially radially about a central junction 803. Each umbrella member 801 can comprise a tissue hook 802, in the figure a double hook, spaced from the junction of the member and the central junction 803. The central junction 803 can include a central lumen for a guidewire, and is adapted to engage a plurality of opposite facing members 804, which opposite facing members can optionally have hooks, tissue penetrators, or feet. The opposite facing members can comprise memory material, and be configured such that they force a retaining lock 805 over the open umbrella members 1 (shown open in Figure 8c) forcing them to close (as shown in Figure 8d).

[0030] A closed loop of string or suture (not shown) can be joined to the device by ways of a lumen or loop. Figure 8a shows the device preassembly. In Figure 8b, the device is in assembled form and in a closed position, where the central junction 3 has passed through the retaining lock 805. In this form the double action vascular closure apposition device can reside within a delivery catheter before being placed in the puncture wound of a blood vessel. Figure 8c shows the device partially expelled from the sheath (not shown), where the umbrella members 801 have opened and engaged the vessel wall, analogous to the embodiments previously described. In the arrangement of Figure 8c, the opposite facing members 804 are retained in the sheath so that they are prevented from forcing the lock 805 over the umbrella members 801. Figure 8d shows the device completely expelled from the delivery sheath, where the opposite facing members 804 are now forcing the retaining collar or lock 805 down the umbrella members 801, causing the portions of the umbrella members 801 with tissue engagement features (hooks in the figure) together (i.e., closing of the umbrella). The opposite facing members 804 are shown for ease of illustration as wire-like; they can be configured as coiled or semi-coiled structures, strut-like, multiple angles, spring-like, curled in an opposite direction, single or multiple members, elbow-like, or other geometrical or curvilinear shapes that when extended are neutral to the retaining lock, but when expelled, force the lock over the umbrella members, initiating closure.

[0031] Accordingly, the double action vascular closure apposition device of Figure 8 is first closed, then opens, and then closes again, the second closure occurring spontaneously by contraction of the opposite facing members against the retaining lock. After the device has been delivered and vascular closure is complete, then the guidewire can be removed.

[0032] Figure 9 (a,b,c,) is a lateral view of a collarless double-action vascular closure apposition device. Figure 9a shows the device in the closed position. A plurality of umbrella members 901 are disposed substantially radially about a central junction 905, which can have a lumen for a guidewire. The central junction can comprise a retaining ring which permits the members to flex along their length. Each of the umbrella members 901 has a tissue engagement feature spaced apart from the central junction 905, in the figure a double hook 902. The central junction is adapted to engage a plurality of opposite facing members 903, which optionally can have hooks, tissue penetrators, or feet 904. The opposite facing members 904 can be composed of memory material, and can be directly joined to a corresponding

umbrella member, with the memory forces in the opposite facing members dominant over the memory forces in the umbrella members. Figure 9a depicts the form that the collarless double action vascular closure apposition device would have while within a delivery catheter before being placed in the puncture wound of the blood vessel.

[0033] Figure 9b shows the device partially expelled from the sheath (not shown). The umbrella members 901 have opened and engaged the vessel wall, analogous to embodiments described previously. The opposite members are still in the closed form, restrained there by the sheath. Figure 9c shows the device completely expelled from the delivery sheath, where the opposite facing members 903 have curled or contracted. Since the opposite facing members are directly joined to the umbrella members and have dominant memory characteristics, they force the umbrella members 901 to close. The opposite facing members are shown in figure as wire-like for ease of illustration; they can be configured as coiled or semi-coiled structures, strut-like, multiple angles, spring-like, curled in an opposite direction, more than two members, elbow-like, or other geometrical or curvilinear shapes that when extended are neutral to the umbrella members, but when expelled, dominate over the umbrella members, and force closure of the umbrella members, initiating puncture wound closure.

[0034] Accordingly, the collarless double action vascular closure apposition device is first closed, then opens, and then closes again, with the second closure occurring spontaneously, by contraction of the opposite facing members which have dominant memory characteristics over the umbrella members. The central junction can be loose enough (e.g., made of a flexible polymer) to permit the forces from the contraction of the opposite facing members to be exerted on the umbrella members. In some embodiments each opposite facing member can be continuous with a corresponding umbrella member (i.e., a first portion of a single wire comprises an umbrella member, a second portion of the same wire comprising an opposite facing member). For simplicity, only two opposing members are shown in the figure; in embodiments where an umbrella member and a opposite facing member are formed from a single wire, the number of umbrella members can equal the number of opposite facing members, and each opposing member-umbrella member can be an integrated piece of memory material. After the device has been delivered and vascular closure is complete, then the guidewire can be removed.

[0035] In any of the embodiments described, the umbrella-like structure, members of this structure or components of the umbrella can be made from any number of suitable materials, including radioopaque materials and materials coated to be made radioopaque, including bioabsorbable polymers or compounds, non-absorbable alloys and compounds including stainless steel, MP35, Nitinol, Nickel-Titanium alloy, Kevlar, nylon polyester acrylic, gold, platinum, tantalum, niobium, molybdenum, rhodium, palladium silver, hafnium, tungsten, iridium. Materials with memory would also be preferable to allow the umbrella to spontaneously open after placement by the sheath. These can be made in the form of wires, fibers, filaments, small beams, and other extruded, woven, or formed shapes. Piano wire, super elastic memory wire, chromium alloys, alloys of titanium and nickel, and other elastic memory materials previously mentioned as well as others can be used as well. The umbrella fabric can be made from a number of suitable materials, including flexible polymeric materials with elastomeric properties including polyurethane, polyethylene, polyestereurethane, polyimide, polyethereimide, polycarbonate, polysiloxane, polyvinyls, hydroxyethylmethacrylate, related polymers, co-polymers of these or other polymers, or drug-

embedded or drug-eluting polymers to prevent coagulation or intimal hyperplasia (such as Taxol), also which can be made radioopaque by markers and addition of appropriate radioopaque materials.

#### Example Embodiments

[0036] The present invention can comprise a device to close puncture wounds caused by catheter procedures and especially angiography comprised of an expandable umbrella-like device that in the compressed state resides in a sheath, and after being expelled from the sheath assumes a planar or conical or other shape, engages vessel wall by means of tissue hooks or penetrators, is collapsed, analogous to umbrella tines, and brings the edges of the vessel wound or puncture into apposition. The device can have a retaining locking device that prevents the umbrella-like structure from reopening. This locking can be achieved by mechanical means including deformable enlargements on the members, dentates, male-female connectors, peg and hole, or other directional mating/locking devices on the members and retaining locking device. This locking device can have a washer like appearance, but can also take a number of different forms, including an inverted umbrella device made of metal, plastic, composites, or biodegradable material.

[0037] The device can have single or multiple hooks and penetrating devices to engage and seize the vessel wall. Each hook can be a single or multiple hook. The device can have members (or tines) of the umbrella-like structure that are linear, curvilinear, spiral, leaf-like, diamond shaped, woven, or other complex shapes, but still function as an opening-closing structure that can accommodate a retaining lock. The device when expanded can have a planar or conical or reverse conical geometry, or other complex shape that can collapse into near-linear form with traction and locking of the retaining lock. The device can have a retrieval fitting, usually a loop, fitted with a closed loop thread, string, or suture in order to apply traction to the device. The device can have a lumen for a guidewire.

[0038] The device can have members that are coated or backed with a fabric or membrane, either completely or partially. The device can elute therapeutic material to prevent thrombogenesis, hemorrhage, inflammation, and intimal hyperplasia with vascular closure. The device can be used in angiography, angioplasty, vascular puncture, tissue biopsy, or trauma that cause a puncture wound that should be closed. The device can comprise materials with memory, so that the device spontaneously assumes its therapeutic shape when expelled from the sheath. The device can comprise at least 2 or more members; 3 or more members can be preferable in some applications. The device can have members with angled dentates or tissue penetrators to prevent movement or migration of the device into the lumen of the blood vessel. These can also be used to retain the retaining lock.

[0039] A tissue opening can be closed according to the present invention by a) introducing a guidewire and sheath, b) penetrating the proximal surface of the blood vessel by the sheath and the guidewire, c) placing a device in the closed form in the sheath, with the loop of string or suture, d) extruding the device from the sheath and expanding while in the tissue (e.g., while inside a blood vessel), e) pulling the device against the tissue wall (e.g., the blood vessel wall), seating the hooks in the tissue, f) partially removing the sheath to seat the device while a retaining lock is advanced, g) advancing the retaining lock over the members of the device while applying traction with the string, forcing them in the closed position, h) bringing the edges of the puncture wound together; if no bleeding occurs, i) then removing the guidewire, j) cutting the loop of string, leaving the device safely seated and locked with the puncture repaired.

[0040] A tissue opening can be closed according to the present invention with sequential delivery of a device. For example, the following steps can be taken 1) first the guidewire and sheath are in place, 2) next the umbrella is pushed down the sheath, either next to the guidewire or with the guidewire in the lumen of the umbrella; 3) the umbrella is extruded, and then using the thread or suture, pulled tight against the lumen of the vessel; 4) next the retaining lock is pushed down the thread and/or guidewire, and is pushed onto the umbrella while applying traction (the sheath can be removed partially at this stage, 5) after the retaining lock is seated, the sheath is observed for bleeding, 6) if there is no bleeding, then the sheath and guidewire are removed.

[0041] A tissue opening can be closed according to the present invention employing a dedicated device consisting of a sheath containing a device, a pushing device to push the device out (e.g., another sheath), a sheath to push the retaining lock, and a thread/suture to oppose the movement of the other sheaths and to retrieve the umbrella if it is misplaced.

[0042] The particular sizes and equipment discussed above are cited merely to illustrate particular embodiments of the invention. It is contemplated that the use of the invention may involve components having different sizes and characteristics. It is intended that the scope of the invention be defined by the claims appended hereto.

**Claims**

We claim:

- 1) A tissue closure device, comprising:
  - a) A junction body;
  - b) A plurality of tissue engagement elements, each having first and second ends, each mounted with the junction body near its first end in a manner that allows the tissue engagement elements to assume first and second configurations, and each comprising a portion spaced from the first end adapted to engage the tissue in both the first and second configurations, wherein:
    - i) In the first configuration, the second ends of the tissue engagement elements are spaced from each other by at least a first distance;
    - ii) In the second configuration, the second ends of the tissue engagement elements are spaced from each other by no more than a second distance, where the second distance is less than the first distance.
- 2) A tissue closure device, comprising a plurality of tissue engagement elements, mounted with each other such that in a first compressed configuration the tissue engagement elements can pass through a tissue opening to be closed, and such that in a second compressed configuration the tissue engagement elements bring the edges of the opening into apposition, and such that in an expanded configuration the tissue engagement elements span the opening, wherein the tissue engagement elements engage the tissue in both the compressed configuration and in the expanded configuration.
- 3) A device as in Claim 2, wherein the tissue engagement elements comprise hooks.
- 4) A device as in Claim 2, wherein the tissue engagement elements comprise wires each having a hook at a first end and slidably mounted with a lock device at a second end, wherein the wires assume the expanded configuration when not constrained by the lock device and assume the compressed configuration when constrained by the lock device.
- 5) A device as in Claim 4, wherein the wires mount together at their second ends with a string receiving element adapted to engage a string such that tension on the string opposed to force on the lock device urges the wires through the lock device substantially along the direction of the tension on the string.
- 6) A tissue closure device, comprising:
  - a) A junction element, having a string engagement portion;
  - b) A plurality of members, where each member has a tissue engagement feature at a first end, and mounted with the junction element such that the members extend away from the junction element defining a truncated cone;
  - c) A lock element comprising a collar defining an interior passage, wherein passage of the junction element through the interior passage manipulates the members such that the area of the base of the truncated cone defined by the members is reduced.
- 7) A device as in Claim 6, wherein the members comprise wires each having a hook at its first end.

- 8) A device as in Claim 6, wherein the members comprise wires each having a plurality of hooks at its first end.
- 9) A device as in Claim 6, wherein the lock element comprises a tissue engagement portion adapted to engage tissue over an area more than three times the area of the interior passage.
- 10) A device as in Claim 6, wherein the junction element comprises a collar defining an interior passage suitable for passage of a guidewire therethrough.
- 11) A device as in Claim 6, wherein each member further comprises one or more secondary tissue engagement features mounted with the member not at the first end.
- 12) A device as in Claim 6, wherein the secondary tissue engagement members comprise projections from the member oriented toward the first end.
- 13) A device as in Claim 6, further comprising a covering extending between the members.
- 14) A device as in Claim 6, wherein the covering comprises a therapeutic material eluted when the device is placed in tissue.
- 15) A device as in Claim 6, wherein the members comprise elongated diamond shaped elements.
- 16) A device as in Claim 6, wherein the members are connected to each other by intermember struts.
- 17) A tissue closure device, comprising:
  - a) A junction element, having a string engagement portion;
  - b) A plurality of members, where each member has a tissue engagement feature at a first end, and mounted with the junction element such that the members extend away from the junction element defining a truncated cone, and having one or more secondary tissue engagement features mounted with the member and oriented toward the first end.
- 18) A device to close openings in blood vessels comprising an expandable umbrella-like device that in the compressed state resides in a sheath; after being expelled from the sheath assumes a planar or conical shape; after being brought into contact with a vessel wall engages the vessel wall; and can be collapsed to bring the edges of the opening into apposition.
- 19) A method of closing an opening in tissue, comprising:
  - a) passing a device, as in Claim 2, while in the first compressed condition through a sheath that penetrates the proximal surface of the tissue;
  - b) expelling the device from the sheath into space beyond the proximal surface of the tissue such that the device assumes the expanded configuration;
  - c) manipulating the device such that the tissue engagement elements engage the tissue;
  - d) causing the device to assume the second compressed configuration, bringing the edges of the opening into apposition.
- 20) A method as in Claim 19, further comprising configuring the device such that it will remain in the second compressed configuration.
- 21) A method as in Claim 19, wherein causing the device to assume the second compressed configuration comprises applying traction to the device.

- 22) A device as in Claim 6, wherein the junction element defines a lumen suitable for passage of a guidewire therethrough.
- 23) A device as in Claim 2, wherein the tissue engagement elements comprise a shape memory material such that the tissue engagement elements assume the expanded configuration unless forced to another configuration.
- 24) A method of as in Claim 19, wherein:
- a) The device comprises a string attachment portion, to which a string is attached;
  - b) Manipulating the device such that the tissue engagement elements engage the tissue comprises pulling the string to encourage the device towards the tissue;
  - c) Causing the device to assume the second compressed configuration comprises passing the string through a central passageway of a locking element, passing the locking element down the string to the device, pulling the string such that a portion of the device engages the locking element, which engagement causes the device to assume the second compressed configuration.
- 25) A tissue closure device as in Claim 2, wherein
- a) the tissue engagement elements comprise elongated members, where each elongated member defines a first portion and a second portion along the length of the member, and are mounted with each other near the boundaries of the first and second portions of the members;
  - b) each tissue engagement element is shaped such that, absent external restraining force, the first portion and second portion of the member form an angle less than 180 degrees to each other, and the mounting of the tissue engagement elements is such that, when the first portions of the members are substantially parallel to each other, the second portions extend approximately radially outward from the mounting, defining the expanded configuration;
  - c) each tissue engagement element comprises a resilient material, such that the members can be forced to a configuration where the first portions of the members and the second portions of the members can be contemporaneously contained within a sheath, defining the compressed configuration.



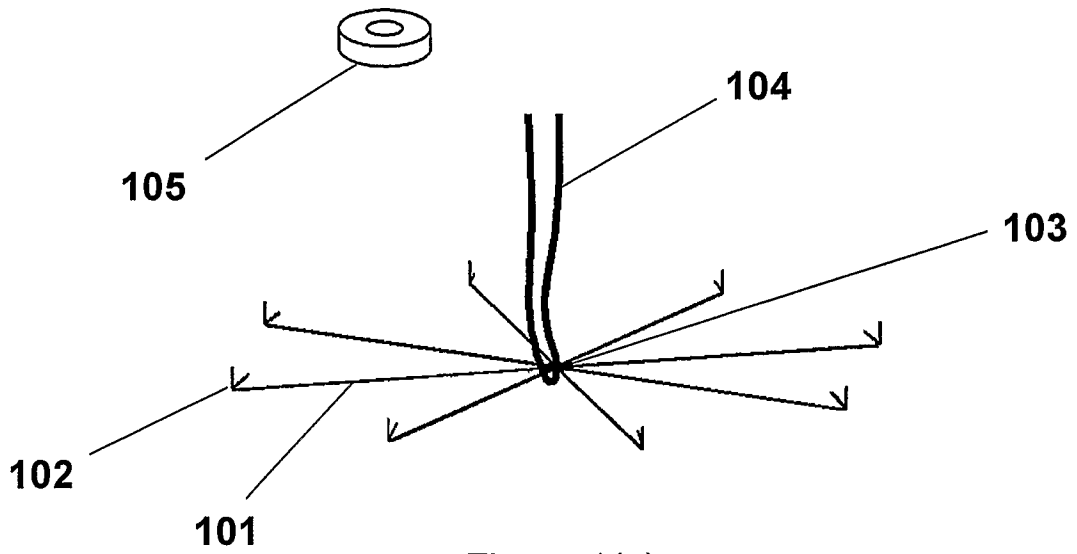

Figure 1(a)

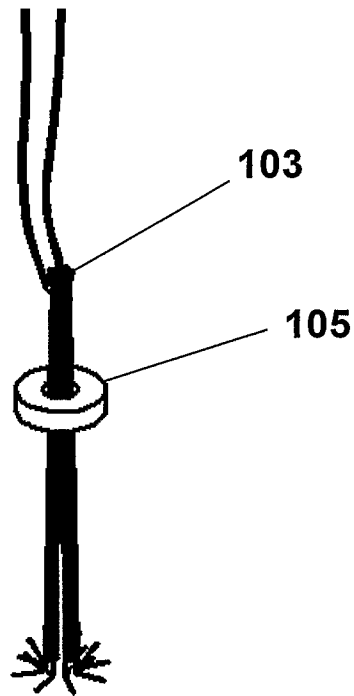

Figure 1(b)

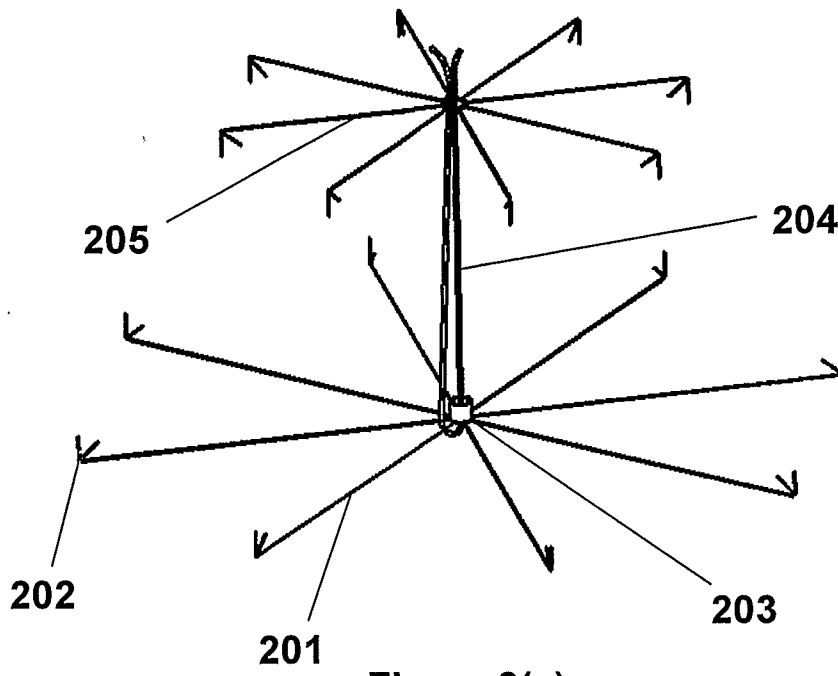

Figure 2(a)

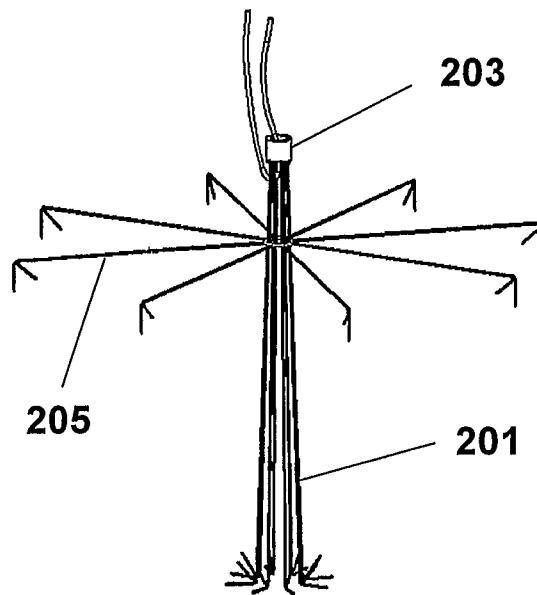

Figure 2(b)

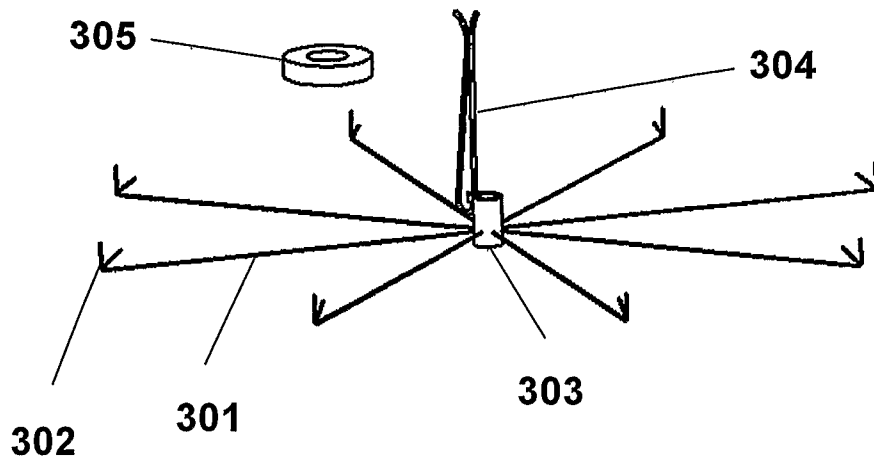

Figure 3(a)

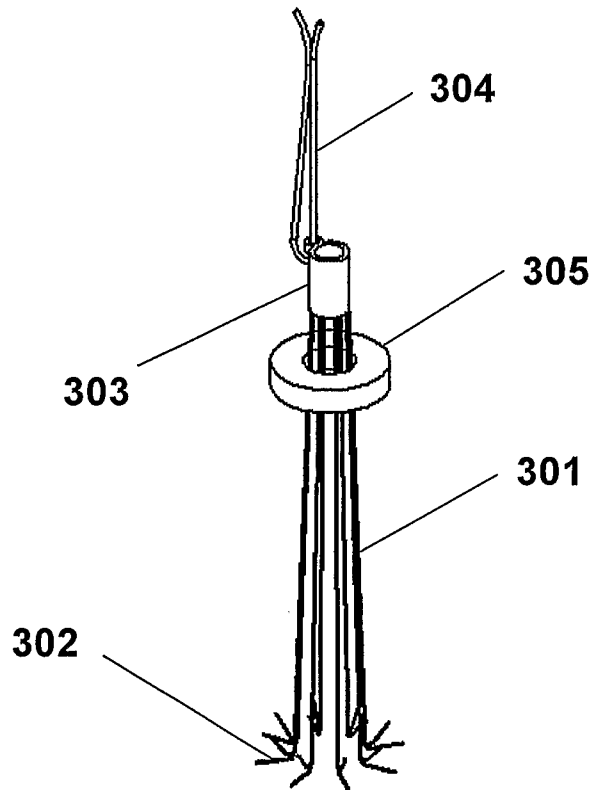

Figure 3(b)

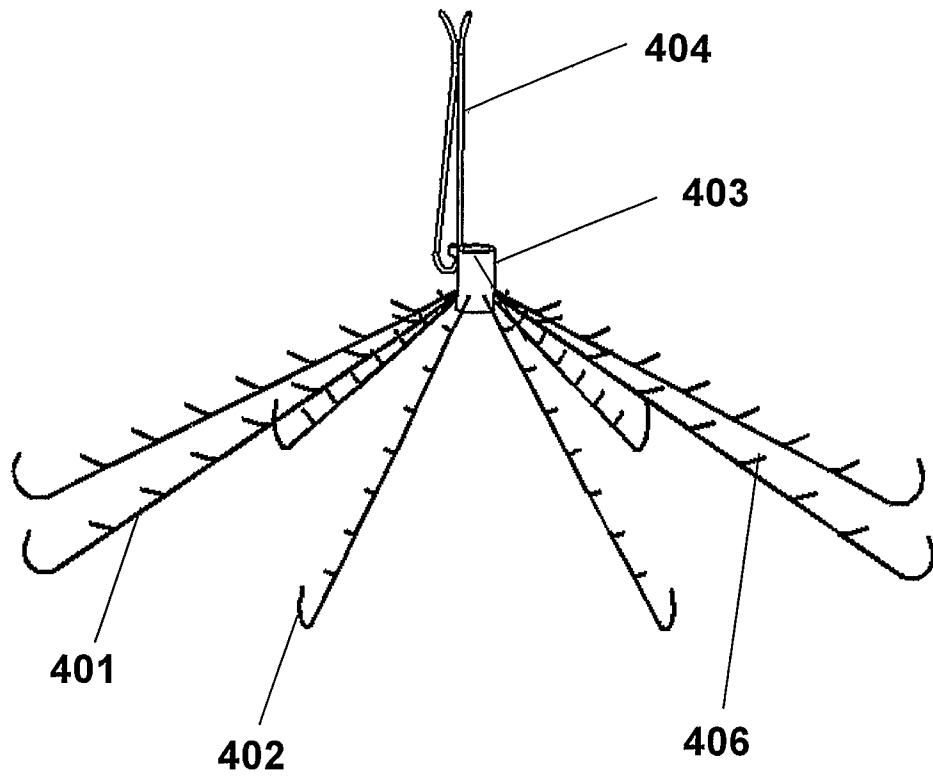

Figure 4

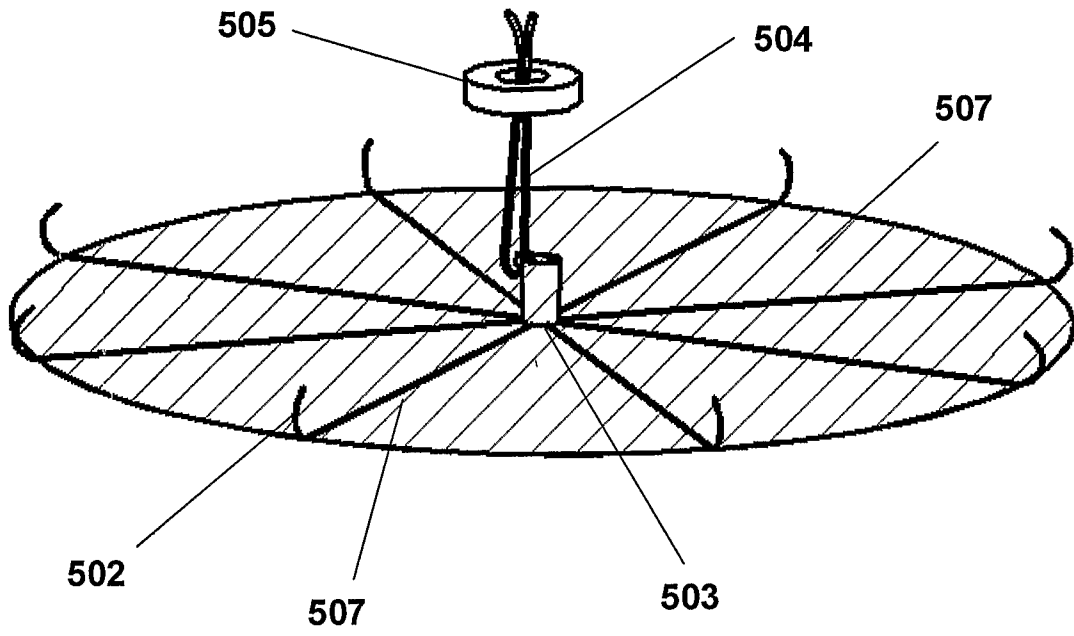

Figure 5

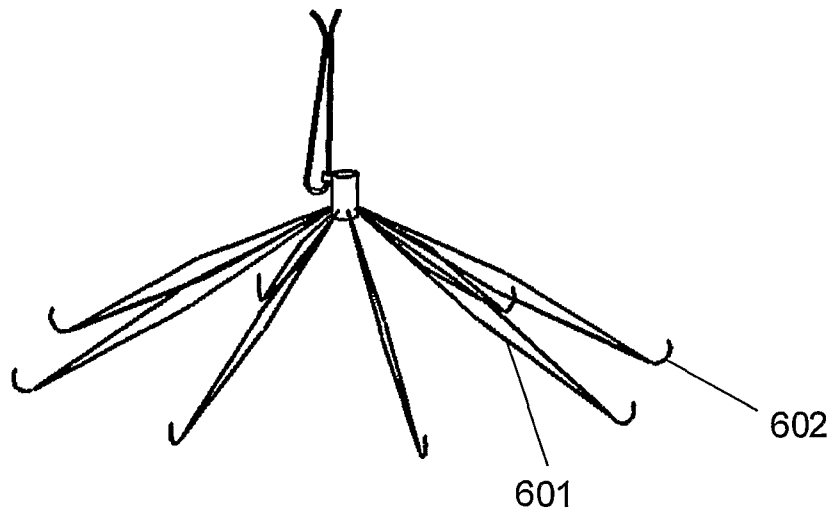

Figure 6(a)

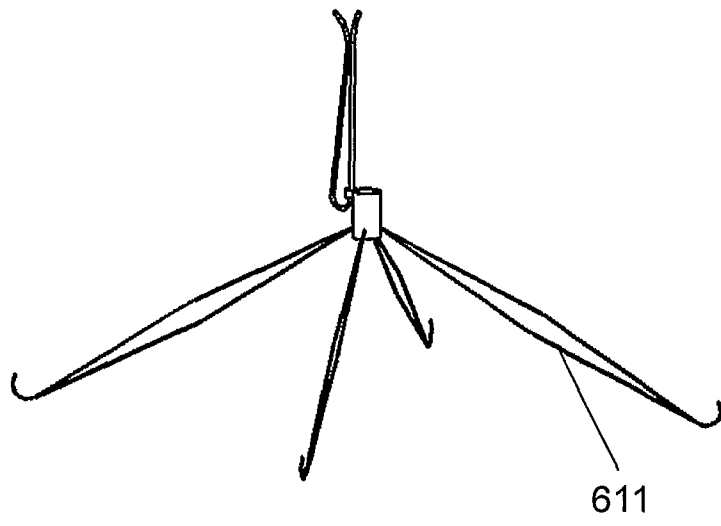

Figure 6(b)

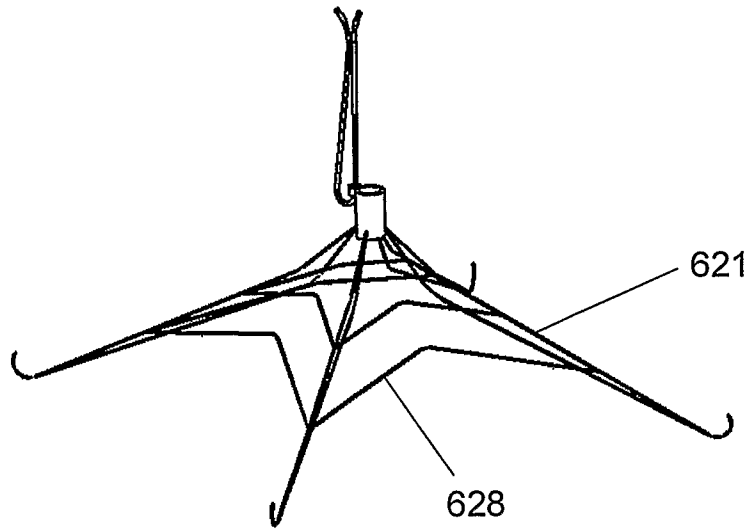

Figure 6(c)

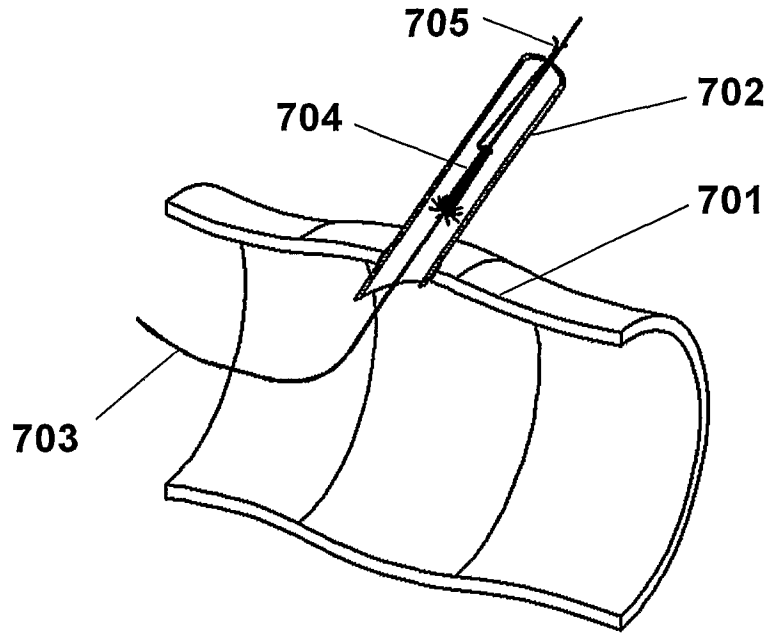

Figure 7(a)

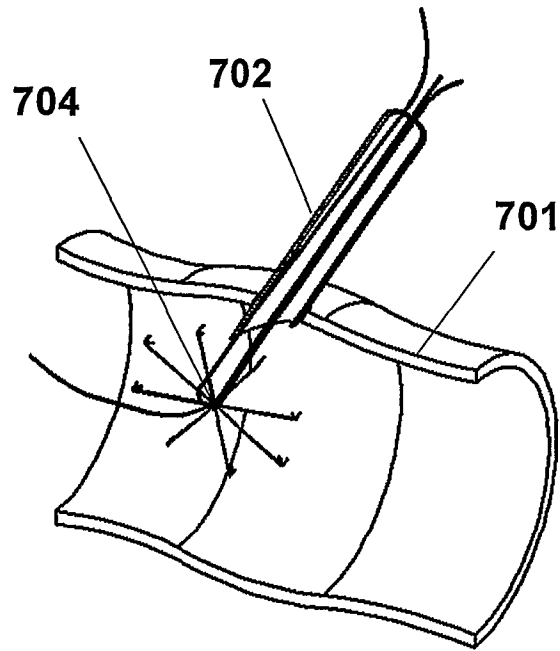

Figure 7(b)



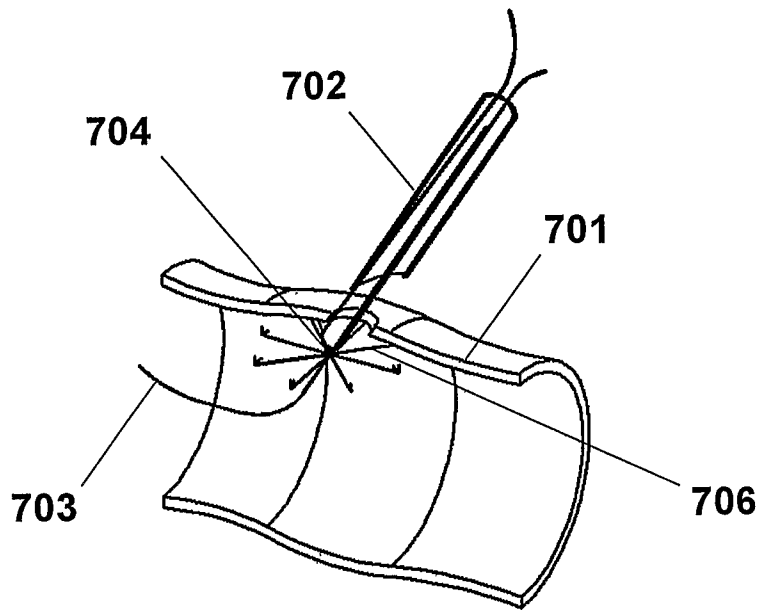

Figure 7(c)

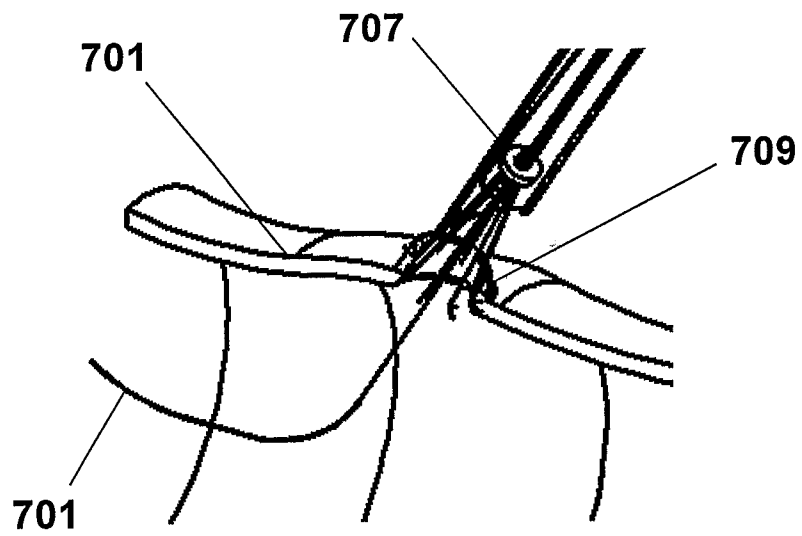

Figure 7(d)

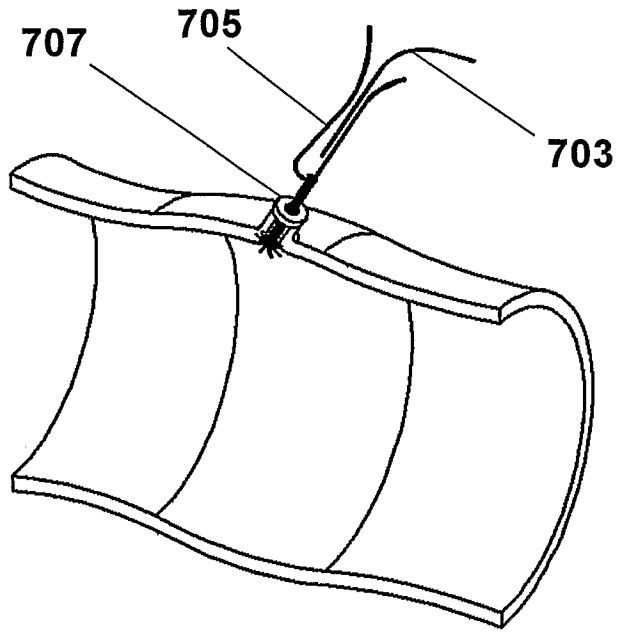

Figure 7(e)

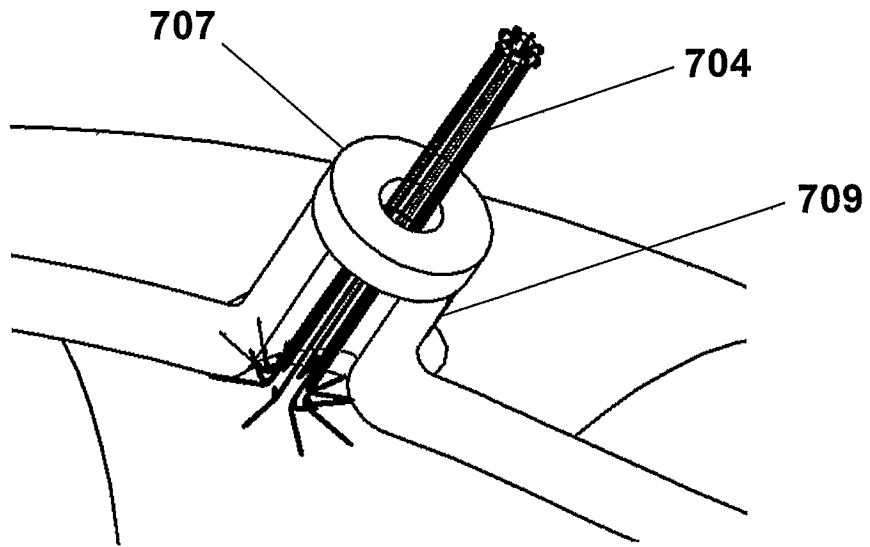

Figure 7(f)