

(19)



(11)

EP 4 003 089 B1

(12)

EUROPEAN PATENT SPECIFICATION

(45) Date of publication and mention of the grant of the patent:
06.11.2024 Bulletin 2024/45

(51) International Patent Classification (IPC):
A45D 1/04 ^(2006.01) **A45D 2/00** ^(2006.01)
A45D 20/10 ^(2006.01)

(21) Application number: **20765062.3**

(52) Cooperative Patent Classification (CPC):
A45D 1/04; A45D 2/002; A45D 20/10; A45D 1/14; A45D 20/50; A45D 2001/004

(22) Date of filing: **29.07.2020**

(86) International application number:
PCT/GB2020/051818

(87) International publication number:
WO 2021/019239 (04.02.2021 Gazette 2021/05)

(54) **APPARATUS AND METHOD FOR DRYING AND STYLING HAIR**

VORRICHTUNG UND VERFAHREN ZUM TROCKNEN UND FRISIEREN VON HAAREN

APPAREIL ET PROCÉDÉ POUR SÉCHER ET COIFFER LES CHEVEUX

(84) Designated Contracting States:
AL AT BE BG CH CY CZ DE DK EE ES FI FR GB GR HR HU IE IS IT LI LT LU LV MC MK MT NL NO PL PT RO RS SE SI SK SM TR

- **HONE, Tim**
London W1D 3SP (GB)
- **STONE, Adam**
London W1D 3SP (GB)
- **SURRIDGE, Ed**
London W1D 3SP (GB)
- **SARGEANT, Anthony**
London W1D 3SP (GB)
- **MOORE, Timothy**
London W1D 3SP (GB)

(30) Priority: **30.07.2019 GB 201910869**

(43) Date of publication of application:
01.06.2022 Bulletin 2022/22

(73) Proprietor: **Jemella Limited**
London W1D 3SP (GB)

(74) Representative: **Pitchford, James Edward Mathys & Squire**
The Shard
32 London Bridge Street
London SE1 9SG (GB)

- (72) Inventors:
- **HARRISON, Alex**
London W1D 3SP (GB)
 - **WEATHERLY, Robert**
London W1D 3SP (GB)
 - **GOLD, Richard**
London W1D 3SP (GB)
 - **WRIGHT, Liam**
London W1D 3SP (GB)

(56) References cited:
WO-A1-2012/033392 WO-A1-2017/046588
WO-A2-2013/104903 US-A1- 2006 191 554
US-A1- 2013 247 407

EP 4 003 089 B1

Note: Within nine months of the publication of the mention of the grant of the European patent in the European Patent Bulletin, any person may give notice to the European Patent Office of opposition to that patent, in accordance with the Implementing Regulations. Notice of opposition shall not be deemed to have been filed until the opposition fee has been paid. (Art. 99(1) European Patent Convention).

Description

Field of the Invention

[0001] The present invention relates to an apparatus for drying and styling the hair of a person (or conceivably an animal), for example after washing the hair or as part of a styling process. That is to say, the hair is wet (or "towel-dry") prior to use of the invention, and may then be dried and styled using the invention. Such drying and styling of the hair may be performed by a user in respect of their own hair, for example, or by a hair stylist. It should also be noted that the term "wet" as used herein should be interpreted broadly, to encompass not only hair wetted by water, but also hair wetted by liquids other than water. For example, hair may be wetted by a solvent-based colourant, which the invention may be used to dry.

Background to the Invention

[0002] Conventional handheld hairdryers, that incorporate an electrically-powered motorised fan to blow a current of cool or hot air in order to dry a person's hair, are well known. The fan draws ambient air into the body of the hairdryer and blows the current of air towards the hair to be dried. When hot air is to be blown, typically an electric heating element, incorporated within the body of the hairdryer, is used to heat the current of air before it leaves the hairdryer. Optionally, the hairdryer may be equipped with a concentrator nozzle attachment to intensify and direct the current of air, or a diffuser attachment to deliver the air more gently.

[0003] However, conventional hairdryers can often be noisy, heavy and bulky. Moreover, they can be awkward to use, and it can be difficult for a user (in particular a domestic user attending to their own hair) to achieve desired results, particularly in respect of styling the hair whilst drying it. For instance, a hairdryer will often be used simultaneously with a hairbrush or comb, or another piece of styling equipment, to style the hair during drying. The styling process may be, for example, to straighten the hair, or to provide "body and volume" to the hair (if necessary, preceded or succeeded by the application of styling products such as mousse, gel, wax, hairspray, etc.). Simultaneously manoeuvring a hairdryer and a brush (or a comb, etc.) around the head can be awkward for the user, and often requires a degree of skill to achieve the desired results.

[0004] Thus, whilst using a conventional hairdryer is the fastest method to dry hair, it can be very difficult and/or time-consuming to create a desired end result in respect of styling. To do this the user has to use a brush and/or additional hair styling tools.

[0005] As an alternative to conventional hairdryers, some people may use products such as hot air brushes or hot air paddle brushes when styling their hair. However, such products, whilst being easy to use, are slow in drying the hair.

[0006] A further category of products, that are both quick and easy to use, are so-called "wet to straight" hair straighteners. These are used to both dry and straighten hair, by drawing wet hair between a pair of heated plates mounted on opposing arms of the device. These devices tend to use conductive heating at high temperatures on wet hair (typically 185-230°C) but can be damaging to hair, and/or may be perceived to be damaging to hair, due to sounds of cavitation (sizzle) or the use of elevated temperatures around the denaturation temperature of wet hair.

[0007] Background art is provided in US 2013/247407 A1, which discloses a hair styling and drying apparatus having a pair of pivotally connected arms, styling surfaces on the arms, air suction and discharge orifices in the styling surfaces, and a blower for blowing air through the air orifices and recycling air between the arms. At least some suction orifices of one styling surface can align with at least some discharge orifices of the other styling surface. The blowers blow air out the discharge orifices and suck air into the suction orifices, thereby recycling much of the blown air. The apparatus can include heaters for heating the blown air and for heating the styling surfaces.

Summary of the Invention

[0008] The present invention aims to provide alternative apparatus and methods to those of conventional handheld hairdryers in order to dry hair, by combining the functionality and benefits of a conventional hairdryer with those of a hair straightener, within one grip-sized device. Thus, advantageously, embodiments of the present invention provide, as a single handheld device, means for both drying and styling the hair, which is simple to use, and less awkward than manoeuvring a conventional hairdryer around the head simultaneously with a brush, comb or other piece of styling equipment.

[0009] More particularly, the present invention provides apparatus as defined in Claim 1 of the appended claims, for drying and styling hair. Details of certain embodiments are set out in the dependent claims. Also provided is a method of drying hair using such apparatus, as defined in Claim 15.

[0010] According to a first aspect of the present invention there is provided apparatus for drying and styling hair, comprising:

first and second mutually-opposing arms adapted for movement between an open configuration for receiving a length of wet hair therebetween and a closed configuration adjacent the hair, such that, in use, when the arms are in the closed configuration they form an inter-arm chamber across which the hair passes, and wherein an airflow conduit is provided within and along at least one of the first and second arms; and
means for delivering a flow of air along the conduit in the at least one of the first and second arms, and

subsequently into the inter-arm chamber.

[0011] The term "chamber" as used herein should be interpreted broadly, to encompass chambers that are partially open on at least one side, as well as those that are enclosed.

[0012] By virtue of the configuration of the present apparatus, including the at least one airflow conduit and the inter-arm chamber formed by the arms when in the closed configuration, this enhances the delivery of air to the hair, enabling the hair to be dried/styled in a quick and easy manner, and also enabling improved energy efficiency to be achieved.

[0013] One or both of the arms further comprises an airflow guide structure arranged to receive the flow of air from the respective conduit and to direct the flow of air from a first direction that is substantially parallel to the length of the respective arm, to a second direction that is from the respective arm towards the opposing arm, into the inter-arm chamber. The provision of such an airflow guide structure further enhances the delivery of air to the hair, further facilitating the drying/styling process, and enabling a further improvement in energy efficiency to be achieved.

[0014] Moreover, according to the invention, first and second plates are disposed on the first arm, and respective opposing first and second plates are disposed on the second arm, wherein the opposing plates disposed on the first and second arms are arranged to come together when the first and second arms are in the closed configuration. Moreover, according to the invention, the inter-arm chamber is located between the first and second plates of the first and second arms when the arms are in the closed configuration and at least one of said plates comprises means for applying heat to said length of hair in use, when the first and second arms are in the closed configuration.

[0015] In a particular embodiment each of the first and second arms comprises a respective conduit and a respective airflow guide structure, and the means for delivering the flow of air is arranged to deliver the air along the conduit in each of the first and second arms and thence through the respective airflow guide structure and into the inter-arm chamber. This enables air to be delivered to the hair in the device simultaneously from above and below, enhancing the drying/styling process.

[0016] Each airflow guide structure may be offset from an imaginary centreline midway between the first and second arms when in the closed configuration. Such an offset advantageously creates an airflow restriction between the air and hair in use, to increase the speed of the airflow around the hair, to increase drying. In a particular embodiment the offset of each airflow guide structure from the imaginary centreline is about 2 mm (i.e. the airflow guide structures are separated from one another by a distance of about 4 mm).

[0017] The conduit in the or each arm may advantageously act as a plenum chamber through which the air

flows into the respective airflow guide structure and thence into the inter-arm chamber. This promotes uniformity of airflow from the or each arm through the respective airflow guide structure and into the inter-arm chamber.

[0018] Preferably the airflow guide structure in the or each arm comprises a cellular structure configured to direct the flow of air from the first direction to the second direction, the cellular structure comprising a plurality of cell walls which extend along the second direction into the respective plenum chamber.

[0019] The depth of the cells into the respective plenum chamber may progressively increase with distance along the respective arm. Such a configuration advantageously causes the incoming airflow in the first direction to turn and exit from the plenum chamber in the second direction and enter the inter-arm chamber with uniform airspeed.

[0020] Alternatively, or in addition, the diameter of the cells of the airflow guide structure in the or each arm may progressively decrease with distance along the respective arm. Such a configuration has been found to provide a more even distribution of airflow along the airflow guide structure.

[0021] In presently-preferred embodiments the cellular structure has a hexagonal (honeycomb) structure. The inventors have found this to be beneficial in maximising the open area through the guide structure whilst minimising the area occupied by the cell walls, and thereby minimising airflow resistance due to the cell walls.

[0022] The or each airflow guide structure may further comprise a plurality of airflow redirecting channels configured to convey the flow of air from the second direction to third and fourth directions that are outward from the apparatus, substantially perpendicular to the length of the arms. By expelling air in these third and fourth directions, this enables air to be easily directed towards the roots of the hair, to dry the roots and enable root lift to be created.

[0023] In presently-preferred embodiments the airflow redirecting channels extend between longitudinal edges and corresponding longitudinal sides of the airflow guide structure.

[0024] Airflow conduits may be provided that extend behind the first and second plates of the respective arm, to receive air from said airflow redirecting channels and to direct airflow behind the first plate and outward through vents along the edge of the apparatus in substantially the third direction, and to direct airflow behind the second plate and outward through vents along the edge of the apparatus in substantially the fourth direction.

[0025] In certain embodiments the airflow guide structure including the cellular structure and the airflow redirecting channels, and the outward vents in the third and fourth directions, may be formed as a unitary structure (e.g. by 3D printing).

[0026] Advantageously the outward vents may be oriented at an angle of about 45° relative to the plane of said plates, to enhance the degree of root lift created.

[0027] The device may further comprise an airflow splitter arranged to divide airflow into the conduits in the first and second arms in the first direction. Optionally the airflow splitter may comprise a flexible member.

[0028] The means for delivering the flow of air may comprise a fan. The fan may advantageously incorporate a brushless motor designed to operate at high speeds (e.g. over 30,000 revolutions per minute) and low power (e.g. 15 W maximum, 3 W during normal operation), and may driven by a DC power supply. Such high-speed low-power parameters of the fan have been found to provide excellent drying performance, drying hair as quickly as a 2000 W conventional hairdryer, but using significantly less power.

[0029] Presently-preferred embodiments further comprise means for heating said airflow, such as one or more heating elements or electrical heating coils, for example.

[0030] Advantageously, the apparatus may further comprise an airflow splitter arranged to direct incoming airflow towards said heating coils, thereby enhancing the efficiency of heat transfer from the coils to the incoming airflow during use. For example, the airflow splitter may be tapered or conical in shape.

[0031] Moreover, the apparatus may further comprise means for performing pulse width modulation in respect of electrical power applied to said means for heating said airflow. This can advantageously be used to regulate the thermal output of the means for heating, irrespective of variations in the power supply voltage (e.g. due to local variations in mains voltage around the world).

[0032] To promote a generally uniform air temperature profile across the air stream, the apparatus may further comprise means for causing turbulence in the heated airflow (such as one or more baffles within the airflow, or a conical or tapered airflow mixing member) prior to the airflow reaching the inter-arm chamber. Alternatively, the means for heating said airflow may comprise the airflow guide structure, the airflow guide structure being formed of a material that generates heat on application of an electric current thereto.

[0033] Optionally the apparatus may further comprise one or more sets of flexible bristles on the first and/or second arms, outside or within the inter-arm chamber, arranged to promote the application of uniform tension to the hair passing across the inter-arm chamber in use.

[0034] Advantageously, to prevent the escape of air past the end of each of the first and second arms, the apparatus may further comprise mutually-opposing spring-loaded sealing elements at the distal tip of said arms.

[0035] Moreover, the apparatus may further comprise at least one airflow deflector on the outer surface of at least one of said arms, shaped and positioned to deflect any rearward-flowing escaping air away from the user's hand. Such an airflow deflector may advantageously be ramp-shaped.

[0036] According to a second aspect of the present invention there is provided a method of drying hair using

the apparatus of the first aspect.

[0037] The method may further comprise using the apparatus to style the hair substantially simultaneously with drying the hair.

Brief Description of the Drawings

[0038] Embodiments of the invention will now be described, by way of example only, and with reference to the drawings in which:

Figure 1 is a perspective overview of a combined hair dryer/styler device comprising means for blowing and heating air, an airflow splitter, and mutually-opposing drying/styling arms in an open configuration, with each arm incorporating a pair of heater plates and an airflow guide structure;

Figure 2 shows the device of Figure 1 with the arms in a closed configuration;

Figure 3 illustrates the device of Figure 1 in use;

Figure 4 is a perspective longitudinal cross-sectional view of the device of Figure 1, showing some exemplary internal components;

Figure 5 is a plan longitudinal cross-sectional view of the device of Figure 1;

Figure 6 is a close-up perspective view of the arms of the device of Figure 1 in the open configuration;

Figure 7 is a side cross-sectional view of the arms of the device of Figure 1 in the open configuration, through the airflow guide structure, showing the airflow guide structure of each arm as having a cellular structure in which the depth of the cells progressively increases with distance along the respective arm;

Figure 8 is a side cross-sectional view as in Figure 7 but with the arms in the closed configuration, and also illustrating directions of airflow along and between the arms;

Figure 9 is a perspective view of the arms of the device of Figure 1 closed around a representation of multiple strands of wet hair;

Figure 10 is a transverse cross-sectional view through the arms of the device of

Figure 1 in the closed configuration, and also illustrating directions of airflow;

Figure 11 is a transverse cross-sectional view corresponding to that of Figure 10, through the arms of the device in the closed configuration (around hair) and showing more detail;

Figure 12 is a perspective longitudinal cross-sectional view along the arms of the device of Figure 1 in the closed configuration around hair, illustrating airflow directional changes due to the airflow guide structure in each arm;

Figure 13 is a perspective transverse cross-sectional view through the arms of the device of Figure 1 in the closed configuration around hair, again illustrating airflow directional changes;

Figure 14 is a perspective view of an arm component

of the device of Figure 1, without plates, again illustrating airflow directional changes;

Figure 15 is a perspective longitudinal cross-sectional view of the arm component shown in Figure 14, again showing the airflow guide structure as having a cellular structure (with hexagonal cells) in which the depth of the cells progressively increases with distance along the structure;

Figure 16 is a perspective longitudinal cross-sectional view of an alternative embodiment of a cellular airflow guide structure, in this case having rectangular cells in one linear dimension (again with the depth of the cells progressively increasing with distance along the structure);

Figure 17 is a perspective longitudinal cross-sectional view of another alternative embodiment of a cellular airflow guide structure, in this case having rectangular cells in two linear dimensions (again with the depth of the cells progressively increasing with distance along the structure);

Figure 18 is a perspective longitudinal cross-sectional view of the airflow splitter of the device of Figures 1-15 in close-up, and also showing a plurality of baffles and a diffuser grille;

Figure 19 is another view of part of the device of Figure 1, showing *inter alia* the plurality of baffles between the fan and the arms;

Figure 20 is a graph of hair sample temperature against drying time, useful for understanding background principles;

Figure 21 is a plan view of an example of an arm component in which the cells of the airflow guide structure are equal in diameter;

Figure 22 illustrates the airflow distribution along the length of the airflow guide structure of Figure 21;

Figure 23 is a plan view of another example of an arm component, in which the cells of the airflow guide structure decrease in diameter along the structure;

Figure 24 illustrates the airflow distribution along the length of the airflow guide structure of Figure 23;

Figure 25 provides exemplary dimensions of the hexagonal cells of the airflow guide structure of Figure 23, by way of example only;

Figure 26 is a side cross-sectional view of an example of an arm component in which heated air and cool air are not mixed prior to reaching the airflow guide structure;

Figure 27 is a side cross-sectional view of another example of an arm component, in which heated air and cool air pass over an airflow mixer prior to reaching the airflow guide structure;

Figure 28 is a perspective view of a heater assembly having an airflow mixer (in the form of an airflow splitter) in the centre;

Figure 29 is a transverse plan view of the heater assembly of Figure 28;

Figure 30 is a transverse cross-sectional view through the arms of a variant of the device of Figure

1 in a closed configuration, and illustrating directions of airflow (with the airflow originating from one arm only);

Figure 31 is a perspective view of a sealing element at one end of an arm of a variant of the present device;

Figure 32 is a side cross-sectional view of the two opposing arms of a combined hair dryer/styler device in a closed configuration, where each arm has a sealing element as in Figure 31 that meet to prevent the escape of air from the end of the device;

Figure 33 is a side cross-sectional view of the two opposing arms of a combined hair dryer/styler device, having a ramp feature behind the heater plate on one of the arms (in this case the top arm) to deflect airflow away from the user's hand;

Figure 34 is a close-up perspective view of the ramp feature of Figure 33;

Figure 35 is a side cross-sectional view of an air heater of a combined hair dryer/styler device, showing (using solid black fill to the left of the figure) an airflow mixer (airflow splitter) as per Figures 27 and 28, to mix the air prior to reaching the airflow guide structure; and (using solid black fill to the right of the figure) an initial airflow splitter to direct incoming airflow towards the device's heating coils;

Figure 36 shows, in relation to the device of Figure 35, plots of internal air temperature over time, in the region of a thermostat (lower line) and a thermal fuse (upper line) within the device, spanning the point when the device is switched from on to off and the internal fan stops; and

Figure 37 shows, by way of comparison, corresponding plots to those of Figure 36, but without the presence of the initial airflow splitter of Figure 35.

[0039] In the figures, like elements are indicated by like reference numerals throughout.

Detailed Description of Preferred Embodiments

[0040] The present embodiments represent the best ways known to the applicants of putting the invention into practice. However, they are not the only ways in which this can be achieved.

Overview of combined hair dryer/styler device

[0041] Figure 1 is a perspective overview of a combined hair dryer/styler device 10 according to a first embodiment, with arms 14, 16 in an open configuration, and Figure 2 shows the same device with the arms 14, 16 closed (as in use, e.g. as shown in Figure 3). Figures 4-15 show further views of parts of the device 10, with Figures 8-14 showing parts of the device in use.

[0042] Referring initially to Figures 1 and 2, the device 10 is an all-in-one handheld device that can be used to dry hair in a quick and easy manner, whilst also enabling

styling of the hair (e.g. to straighten the hair, or to add "body and volume" to it).

[0043] The device 10 comprises a body part 12, and first and second mutually-opposing arms 14, 16 arranged in a broadly similar manner to the arms of a handheld hair styler. The first and second arms 14, 16 are adapted for movement between an open configuration (as shown in Figure 1) for receiving a length of wet hair therebetween, and a closed configuration (as shown in Figure 2) adjacent the hair, to create tension in the hair, such that, in use, when the arms 14, 16 are in the closed configuration they form an inter-arm plenum chamber (13, Figure 10) across which the hair passes.

[0044] Turning briefly to Figure 7, a first airflow conduit 15 is provided within and along the first arm 14, and a second airflow conduit 17 is provided within and along the second arm 16. In alternative embodiments (e.g. as illustrated in Figures 27, 30 and 35) only one of the arms may incorporate such an airflow conduit.

[0045] Referring to Figures 4 and 5, the device further comprises a fan assembly 38 within the body part 12, for delivering a flow of air along the first and second conduits 15, 17 in the first and second arms 14, 16. The fan assembly 38 has an impeller and is typically also provided with a filter.

[0046] As shown for example in Figures 1, 4, 5, 7 and 8, each of the first and second arms 14, 16 further comprises a respective airflow guide structure 24 arranged to receive the flow of air from the respective first or second conduit 15, 17 and to direct (i.e. steer) the flow of air from a first direction (D1, Figure 8) that is substantially parallel to the length of the respective arm (i.e. incoming air, lengthways along the device), to a second direction (D2, Figure 8) that is from the respective arm towards the opposing arm, i.e. inwards into the inter-arm plenum chamber 13 formed by the arms 14, 16 in the closed position. In alternative embodiments, only one of the arms 14, 16 may be provided with such an airflow guide structure 24, if only one of the arms incorporates an airflow conduit. The configuration and function of the airflow guide structure 24 are described in greater detail below. In yet other variants, the airflow guide structure(s) 24 may be omitted altogether.

[0047] As illustrated for example in Figure 1, the first arm 14 is a continuation of the body part 12, and the second arm 16 is coupled to the body part 12 by means of a hinge 18, by virtue of which the first and second arms 14, 16 are movable relative to one other (in the illustrated embodiment, by moving the second arm 16 towards the first arm 14). Thus, the first and second arms 14, 16 can be brought together, into the closed configuration (as shown in Figure 2), or moved apart, into the open configuration (as shown in Figure 1), by a user in use. In the illustrated embodiment, each of the arms 14, 16 widens relative to the body part 12 to form a "head" of the device 10, distal from the body part 12, although other embodiments are possible in which the head does not widen in the illustrated manner.

[0048] The hinge 18 can incorporate any suitable means for allowing the first and second arms 14, 16 to be moved relative to one other.

[0049] Preferably the hinge 18 also incorporates spring means configured to bias the first and second arms 14, 16 into the open configuration, such that the user is required to apply pressure to the arms to close them together (overcoming the effect of the spring means), and such that the arms 14, 16 automatically open, under the effect of the spring means, once the pressure is removed. For example, the hinge 18 may incorporate a leaf spring or a coiled spring.

[0050] The hinge 18 and the spring means can be one and the same. For example, the spring means itself can be used to couple the second arm 16 to the body part 12, thereby avoiding the need to provide a separate mechanical hinge and simplifying the overall construction of the device.

[0051] As shown in Figure 1, and in close-up in Figure 6, in the illustrated embodiment the inner surface of the first arm 14 incorporates first and second elongate heater plates 20a, 20b, parallel to each other and to the length of the arm 14. The second arm 16 also incorporates first and second elongate heater plates 22a, 22b (not visible in Figures 1 and 6, but shown for example in Figures 10 and 11) in corresponding positions to heater plates 20a and 20b. Each of the heater plates is provided with a respective electrical heating element, operable to cause the respective heater plates to heat up. In the illustrated embodiment the operating temperature of the heater plates is typically around 120-130°C.

[0052] The first and second arms 14, 16 and the first and second heater plates on each arm are arranged such that, when the device 10 is in the closed configuration, the first and second heater plates 20a, 20b of the first arm 14 come into contact with the first and second heater plates 22a, 22b of the second arm 16. Preferably the heater plates 20a, 20b, 20c, 20d are made of a material having relatively high thermal conductivity, and are preferably provided with one or more temperature sensors (e.g. a temperature sensor for each plate, or one or more temperature sensors that each serves a plurality of heater plates).

[0053] Optionally, flexible bristles may be provided alongside the heater plates 20a, 20b, 20c, 20d. More particularly, flexible bristles may be positioned on either or both sides of the first arm 14, and/or on either or both sides of the second arm 16, adjacent to the inlet/outlet of the hair to/from the heater plates 20a, 20b, 20c, 20d. Alternatively, or in addition, flexible bristles may be provided within or around the airflow guide structure 24, between the heater plates. Such bristles enable more uniform tension to be applied to the hair fibres within a section of hair passing through the chamber 13 formed by the arms 14, 16 in the closed position.

[0054] As shown in Figure 1, a control button or switch 23 may be provided on the device 10, to enable it to be turned on or off, together with an indicator light to show

whether the power is on. A sound can also be played by a sound generator (not illustrated) when the device 10 is switched on and ready to use.

[0055] As shown in the cross-sectional views in Figures 4 and 5, a fan assembly 38 is mounted towards an end of the body part 12, distal from the first arm 14. The fan 38, driven by an electric motor, is operable to draw in air from the surrounding environment and to deliver a flow of air along the inside of the body part 12; and then into and along the conduits 15, 17 in the arms 14, 16; and then into and through the inter-arm plenum chamber 13 formed by the arms 14, 16 in the closed position, around and through the hair to be dried.

[0056] Advantageously the fan 38 may incorporate a brushless motor designed to operate at high speeds (e.g. over 30,000 revolutions per minute) and low power (e.g. 15 W maximum, 3 W during normal operation), and may be driven by a DC power supply. Such high-speed low-power parameters of the fan have been found to provide excellent drying performance, drying hair as quickly as a 2000 W conventional hairdryer, but using significantly less power.

[0057] An electrically-powered heating coil (or other electrical heating elements), operable to heat the air drawn in by the fan 38, is provided in part 30, towards the end of the body part 12 proximal to the first arm 14.

[0058] The heater plates 20a, 20b, 22a, 22b serve a number of purposes during use of the device 10. Firstly, with the user having sandwiched a length of wet hair between opposing plates 20a and 22a, and between opposing plates 20b and 22b (i.e. transversely across the plenum chamber 13 formed by the first and second arms 14, 16 in the closed configuration), and by drawing the device along the length of wet hair, the heater plates 20a, 20b, 22a, 22b subject the wet hair to a squeeze effect, removing excess unbound water, and also heat the hair to promote subsequent evaporation of the water. Secondly, the heating provided by the heater plates 20a, 20b, 22a, 22b causes the walls of the plenum chamber 13 to be heated (via thermal conduction), and also helps maintain the temperature of the airflow delivered through the plenum chamber 13 by the fan 38. Thirdly, the heater plates 20a, 20b, 22a, 22b can be used to style the hair, as an integral part of the drying process.

[0059] The heater plates 20a, 20b, 22a, 22b are preferably configured as ceramic float plates with springs having a low spring rate or stiffness, thereby giving good control of hair tension.

[0060] Allowing for the airflow heating coil (or other heater elements) and the heater plates 20a, 20b, 22a, 22b, as well as the fan 38, the overall power consumption of the device 10 is around 600-800 W, which is significantly less than a 2000 W conventional hairdryer.

[0061] As shown in Figures 4 and 5, the electrical and electronic circuitry of the device 10 is housed within the body part 12 and the first and second arms 14, 16 (although predominately within the body part 12 and the first arm 14). In the example illustrated, a printed circuit

board assembly 36 is provided within the body part 12. Electrical power is provided to the device 10 by means of a power supply located at the end of the body part 12 distal from the first arm 14. In the illustrated embodiment the power supply is an AC mains power supply. However, in an alternative embodiment the power supply may comprise one or more DC batteries or cells (which may be rechargeable, e.g. from the mains or a DC supply via a charging lead), thereby enabling the device 10 to be a cordless product.

[0062] Amongst other things, the circuit board assembly 36 includes four TRIACs 37, each for powering a respective one of the heater plates 20a, 20b, 22a, 22b.

15 *Airflow guidance*

[0063] The device 10 incorporates a number of features that guide the airflow from the fan 38 to the user's hair 11 so as to enable the hair to be both dried and styled. These features will now be described in detail with particular reference to Figures 7-15.

[0064] As mentioned above, and as shown for example in Figure 7, in the illustrated embodiment each of the first and second arms 14, 16 (at the head of the device 10 distal from the body part 12) comprises a cellular airflow guide structure 24 in airflow communication with a respective first or second conduit 15, 17. The first and second conduits 15, 17 act as plenum chambers to supply air through the guide structure 24 of each of the first and second arms 14, 16.

[0065] Air is supplied to the first and second conduits 15, 17 by the action of the fan 38, via cylindrical part 30. Part 30 includes a heating element to heat the air, and, as shown in close-up in Figure 18, a set of elongate baffles 32 (at a plurality of angles, essentially star-shaped in cross-section), an airflow splitter 34, and a diffuser grille 31.

[0066] The elongate baffles 32 are arranged to mix the air, to reduce hotspots from the heater in the region between the inlet of the air heater and the outlet from the cellular airflow guide structure 24. This is of importance to achieve uniform air temperatures at the outlet of the cellular airflow guide structure 24, thereby achieving uniform drying across the hair section within the chamber 13. It also prevents the formation of hot spots in the air, which could damage the hair. Accordingly, without such baffles it may be necessary to reduce the hair heating power and therefore reduce the drying speed of the device.

[0067] The airflow splitter 34, which is aligned across the diameter of the cylindrical part 30, is arranged to split the incoming airflow into separate upper and lower airflows, which feed directly into the first and second conduits 15, 17. Advantageously, the shape of the airflow splitter 34 is such as to guide the air into the first and second conduits 15, 17 without causing whistling from the air, thereby providing acoustic benefits.

[0068] More particularly, part 30 has a circular cross-

section, the lower half of which (beneath the airflow splitter 34) corresponds with the cross-sectional geometry of the first conduit 15. The upper half of part 30 (above the airflow splitter 34) corresponds with the cross-sectional geometry of the second conduit 17. As shown in cross-section in Figure 8, as the second arm 16 is brought into the closed position the second conduit 17 fits snugly around the upper half of part 30, so that airflow can pass through the part 30, below and above the airflow splitter 34, into the first and second conduits 15, 17, without leaking.

[0069] Thus, as shown in Figure 8, the air enters the first and second conduits 15, 17 in a first direction D1 that is substantially parallel to the length of each of the first and second arms 14, 16.

[0070] As also shown in Figure 8, and in perspective longitudinal cross-section in Figure 15, the airflow guide structure 24 in each of the first and second arms 14, 16 includes a cellular structure comprising a plurality of cell walls. In the illustrated embodiment the cellular structure has a hexagonal (honeycomb) structure, although such a geometry is not essential and other geometries (for example as illustrated in Figures 16 and 17) may be used instead. However, a hexagonal (honeycomb) structure has been found to be beneficial in maximising the open area through the guide structure 24 whilst minimising the area occupied by the cell walls, and thereby minimising airflow resistance due to the cell walls. In the illustrated embodiment the cell width is about one tenth the cell length.

[0071] It should be noted that the depth of the cells of the airflow guide structure 24 into the respective conduit/plenum chamber 15, 17 progressively increases with distance along the respective arm 14, 16, in the direction away from the hinge 18, towards the distal tip of the device. By virtue of this arrangement, incoming air in the first direction D1 is steered from the first direction D1 to a second direction D2 that is substantially perpendicular to the first direction D1, inwardly towards the inter-arm chamber 13 that is formed by the arms 14, 16 in the closed position.

[0072] More particularly, the gradual change in the depth of the cells of the airflow guide structure 24 into the respective plenum chamber 15, 17 advantageously causes the incoming airflow in direction D1 to turn and exit from the plenum chamber in direction D2 and enter the inter-arm chamber 13 with uniform airspeed.

[0073] Figure 8 also shows that, when the arms 14, 16 are in the closed position, the inner face of each airflow guide structure 24 is offset from an imaginary centreline midway between the first and second arms 14, 16 by a distance of 0.5 mm - 4 mm (preferably about 2 mm). The position of the imaginary centreline is where hair 11 under tension will span the inter-arm chamber 13 in use (e.g. as shown in Figure 9). This offset of each airflow guide structure 24 from this imaginary centreline creates an airflow restriction between the air and hair in use, to increase the speed of the airflow around the hair, to in-

crease drying.

[0074] The airflow guide structure 24 also includes a plurality of airflow redirecting channels 28, which extend between longitudinal edges and corresponding longitudinal sides of the airflow guide structure 24, as shown most clearly in Figure 14. These channels 28 are configured to convey the flow of air from the second direction D2 to third and fourth directions D3, D4 that are outward from the apparatus, substantially perpendicular to the length of the arms 14, 16, the fourth direction D4 being opposite to the third direction D3. Figure 13 also illustrates airflow directions D3 and D4. Incidentally, as shown in Figure 14, the airflow guide structure 24 including the cellular (e.g. honeycomb) structure and the airflow redirecting channels 28, along with the outward vents 26 in the third and fourth directions D3, D4, may be integrally formed as a unitary structure, e.g. by 3D printing.

[0075] Turning now to Figure 10, this illustrates further directions of airflow though the arms 14, 16 of the device 10 when viewed in transverse cross-section, facing towards the body part 12 of the device.

[0076] Starting in the centre of Figure 10, the air flowing in direction D2 can be seen entering the inter-arm chamber 13 from the plenum chambers 15, 17 via the cells of the airflow guide structures 24.

[0077] The air is then spread sideways and enters the airflow redirecting channels 28, from which the air then passes along airflow conduits 19a, 19b, 21a and 21b to leave the device via vents 26 in opposing directions D3 (via conduits 19a and 21a) and D4 (via conduits 19b and 21b). As shown in Figure 10, airflow conduits 19a, 19b, 21a and 21b respectively extend behind the heater plates 20a, 20b, 22a and 22b that are mounted on the first and second arms 14, 16.

[0078] For completeness, it should be noted that, although the directions of the airflow D3 and D4 upon leaving vents 26 may be said to be "substantially perpendicular" to the length of the arms 14, 16, the overall path followed by the air as it passes through the airflow redirecting channels 28 and along airflow conduits 19a, 19b, 21a and 21b, and then through the vents 26, is not linear.

[0079] Advantageously, the vents 26 direct the outgoing air towards the roots of the hair, to dry the roots and create root lift.

[0080] Figure 11 is a transverse cross-sectional view corresponding to that of Figure 10, through the arms 14, 16 of the device 10 in the closed configuration (around hair 11) and facing towards the body part 12 of the device. Looking along channels 15 and 17 in the direction of the body part 12, features of the cylindrical part 30 can be seen, including the diffuser grille 31 and the elongate baffles 32 end-on. Other features of Figure 11 correspond to those identified in Figure 10 and described above.

[0081] Figures 12 and 13 illustrate (in perspective longitudinal and transverse cross-sectional views respectively) airflow directional changes due to the airflow guide structure 24 and other features in each of the arms 14,

16 of the device 10.

[0082] As noted above, the first airflow direction D1 is substantially parallel to the length of each of the first and second arms 14, 16, as the air passes the baffles 32 and enters the first and second conduits (plenum chambers) 15, 17 in the respective first and second arms 14, 16. Then the cellular airflow guide structure 24 directs (i.e. steers) the flow of air from the first direction D1 to the second direction D2 inwards into the inter-arm chamber 13 that is formed by the arms 14, 16 in the closed position, through which the hair 11 passes in use.

[0083] The air is then spread sideways and enters the airflow redirecting channels 28, from which the air then passes along airflow conduits 19a, 19b, 21a and 21b behind the heater plates to leave the device via vents 26 in opposing directions D3 and D4.

Technical principles

[0084] The expressions "to dry hair", "drying hair" and the like, as used herein, should be taken to refer primarily to the removal of "unbound" water that exists on the outside of hair when wet. Such "unbound" water should be contrasted with "bound" water, which exists inside individual hairs, and which can be interacted with when heat styling hair. There is no requirement to remove this "bound" water when drying hair in the context of the present invention, although removal of some bound water may occur during the drying process. Further removal of bound water usually occurs during the styling process.

[0085] Figure 20 is a graph of hair sample temperature against drying time, useful for understanding the technical principles associated with the present work. As the temperature of the hair is increased, the hair goes through a warming-up period and then first and second drying periods, as set out below. The first drying period relates primarily to the removal of unbound water, and the second drying period relates primarily to the removal of bound water.

- The "warming-up period": In this phase the ceramic heater plates are used to raise the temperature of the hair to that of the drying period where phase change of the liquid occurs (points A-B). The plates' surface cannot operate over 100-135°C (nominally 120°C) before water cavitation (sizzle) occurs on the plate.
- The "drying period 1": This phase is supported by heated airflow to dry unbound water on the hair (points B-C). Without a freshly heated airflow supporting the evaporation the hair will quickly cool and the drying rate will slow.
- The "drying period 2": This phase (points C-E) occurs when bound water on the hair evaporates and bound water is driven off from within the hair fibre.

- Styling/straightening can be achieved when forces are applied to the fibres and the bound and unbound water is driven off.

5 Problems and solutions provided by the present work

[0086] In the present work the inventors have considered the following problems (amongst others) and have provided the following solutions thereto:

Problem 1 - reducing volume of fan airflow and air heating power to fit within the grip of the user's hand

[0087] The inventors have determined that, in general, drying hair with heated air is an inefficient use of energy, although traditional hair dryer technology is efficient at converting electrical energy to a high temperature airflow. Moreover, using heated air alone to dry hair is very inefficient, with most of the energy being lost in hot air to the atmosphere. To dry hair faster, traditional hair dryers have used higher air pressures and large volume flow rates by employing increasingly high speed motor and fan technologies with air heating to increase drying rates. However, this leads to reduced energy inefficiency, increased unit costs and increased noise levels.

[0088] On the other hand, using conductive heating plates is a very efficient way of heating water and hair to dry, helping to increase a quick-drying, compact and quiet product. However over temperatures of ~100-143°C (nominally) liquid water in contact with the metal plates causes an audible sound of cavitation (sizzle), which causes a perception of damage. Hair temperatures over 143°C can lead to the denaturation of hair.

[0089] A possible solution to this would be to combine heated air blowing through conductive heater plates, but this would present an additional challenge by creating very high airflow resistance. This would require inefficient high-speed motor technologies to achieve the airflow pressures needed to pass hair through the hair and plates).

[0090] The solution provided by the present work is to enclose hair within a heated air plenum chamber 13 between conductive heater plates 20a, 20b, 22a, 22b. This enables the hair to be efficiently heated to evaporate more quickly toward the phase change temperatures of water with plate temperatures of ~100-143°C (nominally 120°C) to avoid cavitation and damage. Moreover, heated plenum temperatures of 125-175°C (nominally 150°C) enables us to efficiently support and maintain phase change and evaporation without cavitation.

Problem 2 - minimising the range of air temperatures and air heating power, due to large variations in airflow resistance of hair

[0091] The inventors have determined that hair, and wet hair in particular, has a large variation in airflow re-

sistance, depending on the size and water content of the section. A solution is therefore needed to avoid excessive temperature rise (hair damage) and large variations in air heater power and fan pressure requirements.

[0092] The solution provided by the present work is that the plenum chamber 13 enclosed around the hair enables heated air to pass around the hair (not just through the hair section), reducing the range of airflow resistance of the system. This helps to reduce the heater power and range in power requirements to regulate the air temperature, thereby increasing energy efficiency and reducing product size and cost.

[0093] By reducing the range of resistance in the airflow requirements of the system this also in turn enables lower speed motors/fans to be used, helping to increase the energy efficiency of the fan, and to reduce sound and cost.

[0094] Moreover, by designing system resistance to accurately meet the airflow and temperature requirements to dry hair when closed, this enables the product's air temperature when open to be cooler, thereby helping to improve the drying experience to the user and reducing losses of energy, and reducing the physical size of the air heater which would otherwise make the product bigger and less easy to use.

Problem 3 - achieving uniform air speed and changing air direction at the hair to air interface

[0095] The inventors have determined that achieving uniform air temperature and speed across the hair-to-air interface is beneficial to maintain drying efficiency. However to achieve this within the context of the present product form requires a method to turn the air, with uniform air speed and pressure at the hair-to-air interface.

[0096] The solution provided by the present work is the provision of an airflow path that incorporates various features for guiding or steering the airflow, as follows:

- The airflow splitter 34, which separates the airflow to the first and second arms 14, 16. It also prevents an excessive or uneven temperature rise on the edge of the section. It should be noted that the airflow splitter 34 can also be made larger and of a flexible material to vent air to the second arm 16 when the device is in the open condition. This prevents air blowing hair off the heater plates 20a, 20b, 22a, 22b when the device is in the open condition and prevents hair restricting the air outlet in the open condition that could lead to increased airflow restriction and resistance in the system, that could otherwise cause overheating and hair damage.
- A plenum chamber 15, 17 within each of the arms 14, 16 that is shaped to allow airflow to fill each of the arms 14, 16, enabling more uniform airflow out of the cells of the cellular airflow guide structure 24.

- The cellular airflow guide structure 24 being of reduced cross-sectional width relative to the width of the arm 14, 16 in which it is located.
- The airflow guide structure 24 of each arm 14, 16 having a cellular (e.g. honeycomb or louvered) structure that extends into the plenum chamber 15, 17 within the respective arm, with the depth of the cells increasing in depth from the end of the arm proximal to the hinge 18, to the end of the arm distal from the hinge 18. This gradual change in the depth of the cells causes the airflow to turn and exit from the plenum chambers 15, 17 with uniform airspeed.
- An open offset distance from the nozzle outlet of the airflow guide structure 24 to the hair (when the first and second arms are in the closed configuration) of 0.5 mm - 4 mm (nominally 2 mm) to create an airflow restriction between the air and hair, to increase the speed of the airflow around the hair, to increase drying. The open cross section between these features allows the air to pass around the hair to the plenum chamber outlet, without having to passing through the hair (which can otherwise restrict the airflow).

Problem 4 - achieving uniform air temperatures in the air stream

[0097] The inventors have determined that achieving uniform air temperature across the air stream can be difficult if air heater windings are placed on the outer perimeter of an air duct (as is conventional practice). This causes the air temperature to be higher on the outer perimeter of the air stream relative to the centre of the air stream, giving a non-uniform distribution of heat across the air stream.

[0098] The solution provided by the present work is to place features in the air stream on the outside of the ring of the heater outlet, or inside the airflow, such as the baffles 32, to cause turbulence in the heated airflow and promote better mixing of air in the air stream before passing the airflow splitter 34. As a result, a more uniform air temperature profile across the air stream can be achieved.

Problem 5 - drying the hair roots and creating root lift

[0099] The inventors have determined that it is desirable to dry hair at the roots, e.g. with a view to creating root lift.

[0100] The solution provided by the present work is to provide air outlet vents 26 at the side and/or rear of the conductive heater plates 20a, 20b, 22a, 22b. These vents 26 direct the outgoing air towards the roots of the hair, to dry the roots and create root lift.

Problem 6 - limitation of plate cavitation (sizzle) with very wet hair over around 100-125°C

[0101] The inventors have determined that plate cavitation (sizzle) with very wet hair over around 100-125°C is a limitation to drying speed.

[0102] The solution provided by the present work is based on the realisation that as the unbound water on the hair evaporates, the plate temperature can be elevated to higher temperatures, to heat and dry hair faster and more efficiently.

[0103] Accordingly, a method is provided to measure the level of unbound water on the hair (moisture sensing), to enable the plate and/or air temperatures to be increased to accelerate the drying rate further. This may be done by providing temperature sensors in the device 10, for example in the following locations:

- location "A" - upstream of the air to hair interface
- location "B" - downstream of the air to hair interface
- location "C" - to sense the temperature of the conductive heater plates, and/or power sensing

[0104] A very large temperature difference between these sensors will indicate the arms 14, 16 are open, as the air will not be channelled past location B. The state of the arms 14, 16 being open can also be sensed by measuring the electrical power needed to elevate the air temperature, as the airflow system resistance will also change between the states of being open, closed, and closed with hair in.

[0105] The thermal loading of the plates in location C will indicate that hair is in the product (from power and/or temperature sensing).

[0106] A high temperature difference between the sensors will indicate water is evaporating (drying hair) and thus the hair is wet. On the other hand, a low temperature difference between the plates will indicate minimal phase change is occurring, so the hair is "dry".

Problem 7 - increasing the cooling rate of the heater plates

[0107] As noted above, the inventors have determined that increasing the heater plate temperature in response to the presence of unbound water in hair enables faster drying. However if the user moves the device to a wetter section of hair the product's plates will ideally need to cool very quickly to prevent cavitation (sizzle) and or hair damage.

[0108] The present work provides a solution to this problem based on actively cooling the heater plates with air (from the fan) that passes over the plates. This enables accelerated cooling of the plates back down to 100-125°C. The air temperature can be controlled for example using an NTC (negative temperature coefficient) device and TRIAC control of the air heater.

[0109] A PTC (positive temperature coefficient) heater

may also be beneficial to enabling a simple and compact conductive heater with an air heat sink.

Problem 8 - regulating the air temperature contacting the hair in open position

[0110] The inventors have determined that it can be advantageous to regulate the maximum temperature rise to hair when the air outlet is restricted with hair during loading, to prevent hair damage, and/or to minimise energy losses to the atmosphere, to deliver cooler feeling air to the user. It is also desirable to regulate the air temperature to achieve fast drying and minimal hair damage.

[0111] The present work provides a solution to this problem by placing a NTC (negative temperature coefficient) device at the air heater outlet, between the air heater and hair contact surface, with a preferred location closest to the hair interface at the outlet nozzle. This enables the NTC to respond to changes in airflow resistance caused by hair restriction or increased temperature differences caused by increased airflow resistance when the arms are open. TRIAC control can be used to regulate the power to the air heater if an upper temperature limit is reached.

Problem 9 - to refresh hair on days when the hair is not washed

[0112] The inventors have determined that users may wish to get a freshly washed and blow dry feeling to their hair on days when they do not have the time, ability or inclination to wash and dry their hair.

[0113] The present work provides a solution to this problem by enabling a fragrance to be emitted into the air stream generated by the device 10, to give the hair a fresh smell. To achieve this, a user-replaceable piezoatomiser and/or a simpler fragrance reservoir and wick may be used to enable phase exchange (liquid to gas) into the air stream and thence onto the user's hair.

Problem 10 - to create a compact air heater to make a compact overall product form

[0114] The inventors have determined that mains powered electrical air heaters are typically heated wire resistors formed to maximise the heated surface area in the air stream. This also adds complexity, size and cost, due to the requirement for a thermal fuse.

[0115] The present work provides a solution to this problem by recognising that a PTC (positive temperature coefficient) heater can enable a new form of air heater that merges the cellular (e.g. honeycomb) airflow guide structure 24 with an air heater, as a single product part. Thus, this merges the functionality of the two parts, making the overall product smaller and more compact. Moreover, because of the PTC effect, this can also negate the need for an additional thermal fuse (and the associated cost).

Problem 11 - portability

[0116] The inventors have determined that consumers desire products that are suitable for "on the go" use, e.g. away from home, or in any event away from plug sockets (e.g. in the bathroom).

[0117] By virtue of the above-described energy savings, the present work enables a low voltage (LV) device 10 to be used for safe operation in the bathroom, and/or enables the device 10 to be used cordlessly (e.g. with a rechargeable battery) and/or a compact isolated power supply.

Modifications and alternatives

[0118] Detailed embodiments and some possible alternatives have been described above. As those skilled in the art will appreciate, a number of modifications and further alternatives can be made to the above embodiments whilst still benefiting from the inventions embodied therein. It will therefore be understood that the invention is not limited to the described embodiments and encompasses modifications apparent to those skilled in the art lying within the scope of the claims appended hereto.

[0119] In the embodiments described above, each of the first and second arms 14, 16 contains a respective airflow conduit 15, 17 and is provided with a respective airflow guide structure 24. However, in alternative embodiments, only one of the arms 14, 16 may be provided with an airflow conduit and airflow guide structure 24. Examples of such variants will be described below and are illustrated by way of example in Figures 27, 30 and 35. In yet other variants, the airflow guide structure(s) 24 may be omitted altogether.

[0120] In the embodiments described above, heater plates are provided symmetrically on either side of each arm 14, 16. However, as those skilled in the art will appreciate, it is not necessary that both these plates be heated, and in alternative embodiments only one plate may be heated, or neither of the plates may be heated. The squeegee effect of the plates may be sufficient in some circumstances to dry the hair in combination with the airflow, without either or both the plates being heated. Furthermore, unheated plates may be used to apply tension to the hair to provide a degree of styling. However, having at least one heater plate is preferred as it helps with the drying/styling process. Moreover, using a pair of heater plates, as in the embodiments described above, advantageously allows for bidirectional/ambidextrous use of the device.

[0121] In the embodiments described above, the airflow guide structure 24 in each of the first and second arms 14, 16 comprises a cellular structure having hexagonal (honeycomb) cells, configured to direct the flow of air from the first direction D1 to the second direction D2. However, in alternative embodiments, the cells of the airflow guide structure may be different shapes. For example, Figure 16 shows an perspective longitudinal

cross-sectional view of an alternative cellular airflow guide structure 24a, in this case having rectangular cells in one linear dimension (with the depth of the cells progressively increasing with distance along the structure, in the same manner as the hexagonal cells described above). As another example, Figure 17 shows a perspective longitudinal cross-sectional view of another alternative cellular airflow guide structure 24b, in this case having rectangular cells in two linear dimensions (again with the depth of the cells progressively increasing with distance along the structure).

[0122] In the embodiments described above, the airflow is heated, e.g. by a heater element in the body 12 of the device, downstream of the fan 38. However, in alternative embodiments the means for heating the airflow may comprise the airflow guide structure 24 itself, the airflow guide structure being formed of a material that generates heat on application of an electric current thereto. In other alternative embodiments the device may not heat the air, relying instead on delivering air at a sufficiently high flow rate to dry the hair.

[0123] Throughout the description and claims of this specification, the words "comprise" and "contain" and variations of the words, for example "comprising" and "containing", means "including but not limited to", and is not intended to (and does not) exclude other components, integers or steps.

[0124] Further alternative features in relation to the embodiments described above have been developed to address particular additional problems or to provide particular additional functionality. These further alternative features (and, as applicable, the particular problems they address or the additional functionality they provide) will now be described in detail.

[0125] To begin with, in order to achieve rapid drying but also a high quality of styling (i.e. high levels of shine, colour retention and style longevity), hair tresses passing through the active styling area (i.e. the head of the styler) should be subjected to even drying and heating across the width of the tress. To do this well, the following five considerations have been found to be important:

- (1) Airflow distribution across the active styling area (i.e. the head of the styler) should be as even as possible.
- (2) The temperature distribution of the air passing through the styling area should be as even as possible.
- (3) The root lifting vents should be arranged to optimise their functionality.
- (4) Air should not be allowed to escape from the tip of the styler when the styler is closed around hair and is being used.
- (5) The styler should perform equally well in any country. Typically there are minor differences in mains voltage between countries which can lead to changes in motor speed and power available to the air heater, hence the energy transferred to the hair

can be different. This should be resolved such that in any country and regardless of mains voltage the energy transfer is the same, to ensure consistent and even performance across the world.

[0126] Safety and quality of the product are also extremely important, of course, and hence the following issues have also been considered and addressed:

- (6) Hot air should not be allowed to flow onto the hand of the user when the styler is being operated.
- (7) A build-up of residual heat in the air heating components (and associated electronics) should be avoided, to prevent inadvertent shutdown or failure of temperature-sensitive components such as a thermal fuse, particularly at the time when the device is switched from on to off.

[0127] The above points (1) to (7) have been addressed through the following further features, as follows:

Further feature 1 - to provide more even airflow distribution across the active styling area (i.e. the head of the styler)

[0128] In the embodiments described above, the design of the cellular airflow guide structure 24 seeks to provide even airflow by using a honeycomb (or other cellular) structure in which the depth of the cells progressively increases towards the distal tip of the device, to effectively "scoop up" more air as it progresses down the length of the head in a direction perpendicular to the depth direction of the cells. While this technique is helpful, with the above-described cellular airflow guide structure 24 it has nevertheless been found that a disproportionate amount of the airflow is still emitted near the distal tip of the device.

[0129] To illustrate this, Figure 21 shows the above-described cellular airflow guide structure 24 of the lower arm 14 of the device, in which the hexagonal cells are equal in diameter. Aligned with Figure 21, Figure 22 illustrates the airflow distribution along the length of the airflow guide structure 24 - i.e. the average emitted air velocity at each longitudinal position along the airflow guide structure 24, from the tip end to the handle end along the head of the device. From Figure 22 it can indeed be seen that a disproportionate amount of the airflow leaves the airflow guide structure 24 near to the distal tip of the device, due to a build-up of airflow towards the tip of the device. This is not conducive to even styling, and will lead to less shine on the hair, and individual strands of hair being blown in unwanted directions (so-called "fly away" hair strands), especially near the tip of the device, due to the greater velocity of the emitted air in that location.

[0130] To resolve this issue, and with reference now to Figure 23, in an alternative (improved) airflow guide structure 24 the diameter of the honeycomb cells is pro-

gressively reduced towards the distal tip of the device, to restrict the airflow. The depth of the cells also progressively increases towards the distal tip of the device, as described above. Figure 24 shows the resulting airflow distribution along the length of the airflow guide structure 24, from which it can be seen that a more even distribution of airflow is achieved, with a peak in airflow located around the midpoint of the airflow guide structure 24, i.e. midway between the tip end and the handle end of the head of the device. Such an airflow distribution leads to more even styling, more shine on the hair, and fewer occurrences of individual strands of hair being blown in unwanted directions.

[0131] Figure 25 provides exemplary dimensions of the hexagonal cells of this alternative airflow guide structure 24. It can be seen that the cells proximal to the handle of the styler have a diameter of 4.2 mm, the cells around the midpoint of the airflow guide structure 24 have a diameter of 3.9 mm, and the cells near to the distal tip of the device have a diameter of 3.3 mm. These dimensions are by way of example only, and may be different in other implementations (whilst still progressively reducing the diameter of the cells towards the distal tip of the device). For the sake of completeness, it should be noted that the progressive reduction in the diameter of the cells need not be continuous along the length of the airflow guide structure 24, but may decrease in a stepwise manner, i.e. in discrete stages.

Further feature 2 - to provide a more even temperature distribution of the air passing through the styling area (i.e. the head of the styler)

[0132] The temperature of the air being passed through the head of the styler should be as even as possible to ensure that drying is even across the tress, to result in better hair fibre alignment and improved shine and style longevity. The above-described structure (e.g. with reference to Figure 7) whereby air passes from part 30 into the first airflow conduit 15 (provided within and along the first arm 14) and into the second airflow conduit 17 (provided within and along the second arm 16) has been found to not provide as even a temperature distribution as would be desirable. This is due to the manner in which the airflow into the conduits 15, 17 is created, and the design of the heater - particularly the annular configuration of the heating element which leads to a cooler centre core of the airflow.

[0133] The result of this issue is that a difference of over 30°C in the temperature of the emitted air may be observed from one end of the airflow guide structure 24 to the other. For instance, in representative experimental tests, an emitted air temperature of 51°C was measured near to the proximal end of the airflow guide structure 24 (i.e. close to the handle), a temperature of 71°C was measured around the midpoint of the airflow guide structure 24, and a temperature of 86°C was measured near to the distal end of the airflow guide structure 24, near to

the tip of the device.

[0134] A similar situation is illustrated in Figure 26, in which heated air is emitted near the distal end of the airflow guide structure 24, and cool air is emitted at the proximal end of the airflow guide structure 24. This is due to the annular configuration of the heating element 40 (within a heater assembly 44) which causes regions of heated air to be generated adjacent to the heating element 40, and a cooler central core of air to be generated between the heated regions.

[0135] In passing, it should also be noted that Figure 26 (and subsequently Figures 27, 30 and 35) show a variant of the first arm 14 in which all the incoming airflow is directed along the first airflow conduit 15, and thence through the airflow guide structure 24. That is to say, in this example, the second arm 16 does not comprise a second airflow conduit for delivering air to the head of the styler (but may nevertheless comprise an airflow guide structure in communication with the inter-arm chamber 13, for receiving the air emitted from the first arm 14). Conversely, in another variant, all the incoming airflow may be directed along the second airflow conduit 17, within the second arm 16, and none along the first arm 14. Such variants may enable easier manufacture of the overall device, and may also improve airflow performance, as they avoid having opposing airflows from the first and second conduits 15, 17 coming into conflict with one another and causing turbulence within the inter-arm chamber 13, and moreover provide a well-defined "escape route" for moisture-laden air.

[0136] With reference to Figure 27, the above issue of uneven temperature distribution may be addressed by providing an airflow mixer 42, in this case in the form of an airflow diverter or splitter, near to the end of the heater assembly 44, before the airflow conduit 15. The airflow mixer 42 causes the heated air (from adjacent to the heating element) to mix with the cooler central core of air, to provide a more evenly heated flow of air along the airflow guide structure 24. The airflow mixer 42 may be generally tapered or conical in shape, as illustrated, or some other shape so as to cause turbulence and mixing of the air within the airstream.

[0137] By virtue of the airflow mixer 42 removing or reducing the cool core of air, the temperature difference of the emitted air from one end of the airflow guide structure 24 to the other can be considerably reduced. For instance, in comparative experimental tests in which the airflow mixer 42 was present, an emitted air temperature of 68°C was measured near to the proximal end of the airflow guide structure 24 (i.e. close to the handle), a temperature of 82°C was measured around the midpoint of the airflow guide structure 24, and a temperature of 80°C was measured near to the distal end of the airflow guide structure 24, near to the tip of the device. Accordingly, in this case, the difference in temperature from one end of the airflow guide structure 24 to the other was only 12°C.

[0138] Figure 28 is a perspective view of the heater

assembly 44 as present within Figure 27, showing the airflow mixer 42 in the centre. Similarly, Figure 29 is a transverse plan view of the heater assembly 44 of Figure 28, and also showing a representation of the heating coils 40.

Further feature 3 - to improve the functionality of the root lifting vents

[0139] In the embodiments described above and as illustrated in Figure 10, for example, the root lifting vents 26 are located along either side of the head of the styler head and extend parallel to the plane of the heater plates 20a, 20b, 22a, 22b.

[0140] However, with reference now to Figure 30, further development work has found that improved lifting of the roots of the hair may be achieved if the air leaves the vents 26 at around 45° to the plane of the heater plates 20a, 20b, 22a, 22b, in directions D3' and D4', rather than parallel to the plane of the heater plates. This means the air flow direction D4' is not opposite to D3' on either side of the styler head (unlike directions D3 and D4 shown in Figure 10). Rather, the air flow directions D3' and D4' are at around 90° to each other, on either side of the styler head. Other angles between the air flow directions D3' and D4', emitted from the roof lifting vents, are also possible.

[0141] Having the root lifting vents 26 oriented at an angle that is not parallel to the plane of the heater plates 20a, 20b, 22a, 22b has been found to be beneficial, as when the root lifting air flow is parallel to the heater plates, it has been found to create "fly away" hair strands and reduces alignment of the hair fibres, thus reducing the end result of shine and style longevity. It has therefore been found that an angle of around 45° reduces the creation of "fly away" hair strands, while still providing an angle of flow which makes it easy for the user to create root lift. If the angle is substantially larger than 45°, creating root lift becomes more difficult.

[0142] From the cross-sectional illustration of Figure 30, it should also be noted that, in this variant of the head of the styler, the incoming airflow is only along the first airflow conduit 15, from which it passes (in direction D2) through the airflow guide structure 24 and into the inter-arm chamber 13. Thus, in this variant, the second arm 16 does not comprise a second airflow conduit for delivering air to the head of the styler, but nevertheless includes airflow redirecting channels 28 for receiving some of the air emitted from the first arm 14 and delivered via the airflow guide structure 24 through the inter-arm chamber 13.

[0143] From the inter-arm chamber 13, the air is then spread sideways (e.g. by means of angled surfaces 46 incorporated within the second arm 16) and enters the airflow redirecting channels 28, from which the air then passes along airflow conduits 19a, 19b, 21a and 21b to leave the device via vents 26 in 45° directions D3' (via conduits 19a and 21a) and D4' (via conduits 19b and

21b). As shown in Figure 30, airflow conduits 19a, 19b, 21a and 21b respectively extend behind the heater plates 20a, 20b, 22a and 22b that are mounted on the first and second arms 14, 16.

Further feature 4 - to reduce instances of escaped air from the distal tip of the styler

[0144] In the embodiments described above, it has been found that, when the styler is closed with hair between the heater plates, it is possible for air to escape from the distal end of the styler, particularly at the end of the heater plates. This has been found to reduce the drying rate, since less air passes through the hair tress, and also to lead to fibre alignment issues.

[0145] However, with reference now to Figures 31 and 32, following further development work this issue of escaped air from the distal tip of the styler has been resolved by providing mutually-opposing spring-loaded non-thermally-conductive (e.g. plastic) sealing elements 48 on both the top and bottom styler arms 14, 16, at the distal tip of the device. The sealing element 48 is flat and also stands proud of the adjacent heater plates (e.g. 20a, 20b) to ensure that, when the heater plates are loaded with hair, the top and bottom sealing elements 48 come together to create a seal which prevents air escaping from the tip of the styler along the heater plates. A spring, by means of which each sealing element 48 is mounted, allows for varying amounts of hair to be placed between the heater plates and for a seal to still be maintained.

Further feature 5 - to enable consistent performance around the world

[0146] It is desirable that the styler product should have substantially the same performance wherever it is used around the world, even though mains voltages may vary from country to country. Mains voltage variation particularly impacts the temperature of the heated air within the device, since the air is heated using a standard resistive wire heater, and the electrical power consumed by such a heater and converted to heat is a function of voltage. It is therefore desirable to ensure that the energy transferred to the air is the same, regardless of the location of the device around the world, to ensure that the drying rate is the same and the product does not damage the hair fibre.

[0147] Control of energy transfer to the air can be achieved in various ways - for example, by varying the fan speed (which is undesirable since it affects the amount of airflow), or by using a variable resistor in the heater (which is also undesirable). Another option, which we have found to work well, is to control the temperature of the heater by means of an electrical switching technique, whilst keeping the fan speed constant. For instance, the number of mains cycles across the heater per second may be controlled using a standard zero-crossing switching technique employing triacs, essential-

ly performing pulse width modulation of the electrical power supplied to the heater. In such a manner the thermal output of the heater element, and the device more generally, can be controlled irrespective of variations in local mains voltage.

Further feature 6 - to prevent hot air from flowing onto the hand of the user when the styler is being operated

[0148] For the sake of safety and comfort, air should not be able to flow back onto the user's hand, given that the temperature of the air can be in excess of 100°. In internal tests using an early prototype of the styler, it was found that, when styling, it was possible for hot air to escape from the end of the heater plates closest to the handle/hinge, and that this risked causing discomfort to the user.

[0149] To address this issue, and with reference to Figures 33 and 34, a ramp-like airflow deflector feature 50 (also shown in Figure 32) has been developed for inclusion at the proximal end (i.e. handle end) of each of a pair of heater plates, i.e. either plates 20a and 20b, or plates 22a and 22b, to prevent hot air from escaping backwards towards the user's hand. The ramp-like shape of the deflector 50 is important for two reasons: it stops the air from passing backwards, and does not trap the user's hair during styling. In comparison, a standard "block" form would risk creating pinch points that would pull and trap the user's hair. The ramp design of deflector 50 prevents this from happening, and also redirects the back-flowing air (that would otherwise escape towards the user) towards the opposing arm of the device, to prevent discomfort to the user's hand.

Further feature 7 - to avoid the build-up of residual heat in the air heating components (and associated electronics), particularly at the time when the device is switched from on to off

[0150] For safety reasons, the styler device will ordinarily contain a thermostat and a thermal fuse, either of which will cause the device to stop working when tripped (or, in the case of the thermal fuse, when blown). The thermostat is resettable and is designed to protect against accidental blockage of the air inlet to the device, or lack of filter cleaning. If the thermostat is tripped, the device can be used again once it has cooled back down.

[0151] However, the thermal fuse blowing is a more permanent issue (requiring the fuse to be replaced), and is designed to protect the device against an uncontrollable catastrophic failure, such as a commutation failure in the triacs driving the air heater. The thermal fuse failing would render the product unusable until the fuse is replaced. Hence, it is not desirable for the fuse to fail during normal and safe use.

[0152] In internal tests using an early prototype of the styler, it was found that, when the unit is switched from on to off (i.e. at the end of a period of use) and the internal

fan consequently stops, the temperature of the air heating components in the area of the thermostat and thermal fuse could peak to high temperatures. After a number of cycles of operation and an extended period of time, such temperature peaks could cause either the thermostat to trip or the thermal fuse to blow, particularly in the extreme case of blocked filters. (Also both components have a high variance in activation temperature from the nominal activation temperature, and degrade with age.) Such tripping of the thermostat or blowing of the thermal fuse would cause an undesirable fail in a safe device that is otherwise working normally.

[0153] One way of addressing this is to cause the internal fan to continue to operate in a so-called "ramp-down" mode when the device is switched from on to off. Accordingly, the fan would continue to run for a short period of time to reduce the residual heat in the heating components and associated electronics. That is to say, the fan in ramp-down mode would remove the residual heat from the system by causing the passage of a flow of air over said components.

[0154] However, it was found that, should someone unplug the device rather than simply switch off the product using its on/off switch, the temperature would peak as previously, since the fan would not enter its ramp-down mode.

[0155] With reference to Figure 35, this issue has been resolved by providing an initial airflow splitter 52 at the entrance to the heater assembly 44. The airflow splitter 52 has a generally tapered or conical shape, to direct incoming airflow from the fan towards the heating coils 40 (rather than simply passing along the centre of the heater assembly 44). By specifically directing the incoming airflow over the heating coils 40 in this manner, this provides more efficient transfer of heat from the coils 40 to the incoming airflow during use. Moreover, since the coils 40 are run more efficiently, with more of the heat being transferred from the coils to the incoming airflow, there is less build-up of heat in the coils (and associated electronics) themselves, thus keeping them generally cooler. As a consequence, when the device is switched from on to off, there is less residual heat in the heating system. Accordingly, even if the fan is suddenly turned off, components such as the thermostat and thermal fuse are exposed to less severe peaks in temperature, such that they do not trip or blow.

[0156] To illustrate this further, Figure 36 shows plots of internal air temperature over time, in the region of the thermostat (lower line) and the thermal fuse (upper line) within a styler device having an airflow splitter 52. The plots span the point when the device is switched from on to off and the internal fan stops. It can be seen that, at the point when the device is switched off and the fan stops, a modest thermal spike of about 80°C is experienced in the vicinity of the thermostat and thermal fuse, reaching a maximum temperature of about 140°C. This thermal spike is within the permitted operating temperatures of those components and causes neither compo-

nent to trip or blow.

[0157] By way of comparison, Figure 37 shows corresponding plots of internal air temperature over time, in the region of the thermostat (lower line) and the thermal fuse (upper line) within a test styler device that does not have an airflow splitter 52. Again, the plots span the point when the device is switched from on to off and the internal fan stops. It can be seen that, at the point when the device is switched off and the fan stops, a more pronounced thermal spike of about 100°C is experienced in the vicinity of the thermostat and thermal fuse. A maximum temperature of about 160°C is reached in the vicinity of the thermal fuse, which may in some cases be sufficient to cause this component to blow. Accordingly, such an issue is prevented by the provision of the airflow splitter 52.

[0158] Figure 35 also shows the airflow mixer 42 from Figures 42-47, although the airflow mixer 42 and the airflow splitter 52 need not necessarily both be present. However, synergistic advantages can be realised if the airflow mixer 42 and the airflow splitter 52 are both present - i.e. in respect of more efficiently heating the incoming air, and delivering the heated air more evenly to the user's hair.

[0159] Indeed, a well-functioning styler device with numerous synergistic advantages may be obtained by implementing all of the above "further features" 1 to 7 in a single device. However, any of the "further features" 1 to 7 may be omitted if desired. Indeed, none of the "further features" 1 to 7 should be considered essential to the present invention in its broadest sense, the scope of which is defined by the appended claims.

Claims

1. Apparatus (10) for drying and styling hair, comprising:

first and second mutually-opposing arms (14, 16) adapted for movement between an open configuration for receiving a length of wet hair therebetween and a closed configuration adjacent the hair, such that, in use, when the arms are in the closed configuration they form an inter-arm chamber (13) across which the hair passes, and wherein an airflow conduit (15, 17) is provided within and along at least one of the first and second arms (14, 16);
 means (38) for delivering a flow of air along the conduit (15, 17) in the at least one of the first and second arms (14, 16), and subsequently into the inter-arm chamber (13); and
 first and second plates (20a, 20b) disposed on the first arm (14), and respective opposing first and second plates (22a, 22b) disposed on the second arm (16), wherein the opposing plates (20a, 20b, 22a, 22b) disposed on the first and second arms (14, 16) are arranged to come to-

- gether when the first and second arms (14, 16) are in the closed configuration; wherein the inter-arm chamber (13) is located between the first and second plates (20a, 20b, 22a, 22b) of the first and second arms (14, 16) when the arms are in the closed configuration; wherein at least one of said plates (20a, 20b, 22a, 22b) comprises means for applying heat to said length of hair in use, when the first and second arms (14, 16) are in the closed configuration; and wherein one or both of the arms (14, 16) further comprises an airflow guide structure (24) arranged to receive the flow of air from the respective conduit (15, 17) and to direct the flow of air from a first direction (D1) that is substantially parallel to the length of the respective arm (14, 16), to a second direction (D2) that is from the respective arm (14, 16) towards the opposing arm (16, 14), into the inter-arm chamber (13).
2. Apparatus according to claim 1, wherein the conduit (15, 17) in the or each arm (14, 16) acts as a plenum chamber through which the air flows into the respective airflow guide structure (24) and thence into the inter-arm chamber (13), and wherein the airflow guide structure (24) in the or each arm (14, 16) comprises a cellular structure configured to direct the flow of air from the first direction (D1) to the second direction (D2), the cellular structure comprising a plurality of cell walls which extend along the second direction (D2) into the respective plenum chamber.
 3. Apparatus according to claim 2, wherein the depth of the cells into the respective plenum chamber progressively increases with distance along the respective arm (14, 16), or wherein the diameter of the cells progressively decreases with distance along the respective arm (14, 16).
 4. Apparatus according to claim 2 or claim 3, wherein the cellular structure has a honeycomb structure.
 5. Apparatus according to any of claims 2 to 4, wherein the or each airflow guide structure (24) further comprises a plurality of airflow redirecting channels (28) configured to convey the flow of air from the second direction (D2) to third and fourth directions (D3, D4) that are outward from the apparatus, substantially perpendicular to the length of the arms (14, 16), and preferably wherein the airflow redirecting channels (28) extend between longitudinal edges and corresponding longitudinal sides of the airflow guide structure (24).
 6. Apparatus according to claim 5, further comprising airflow conduits (19a, 19b, 21a, 21b) that extend behind the first and second plates (20a, 20b, 22a, 22b) of the respective arm (14, 16), arranged to receive air from said airflow redirecting channels (28) and to direct airflow behind the first plate (20a, 22a) and outward through vents (26) along the edge of the apparatus in substantially the third direction (D3), and to direct airflow behind the second plate (20b, 22b) and outward through vents (26) along the edge of the apparatus in substantially the fourth direction (D4).
 7. Apparatus according to claim 6, wherein the airflow guide structure (24) including the cellular structure and the airflow redirecting channels (28), and the outward vents (26) in the third and fourth directions (D3, D4), are a unitary structure, and/or wherein the outward vents (26) are oriented at an angle of about 45° relative to the plane of said plates (20a, 20b, 22a, 22b).
 8. Apparatus according to any preceding claim, wherein the means for delivering the flow of air comprises a fan (38).
 9. Apparatus according to any preceding claim, further comprising means (40) for heating said airflow.
 10. Apparatus according to claim 9, wherein said means for heating said airflow comprises electrical heating coils (40), and preferably further comprising an airflow splitter (52) arranged to direct incoming airflow towards said heating coils (40), and preferably wherein the airflow splitter (52) is tapered or conical in shape.
 11. Apparatus according to claim 9 or claim 10, further comprising means for performing pulse width modulation in respect of electrical power applied to said means (40) for heating said airflow.
 12. Apparatus according to any of claims 9 to 11, further comprising means (32, 42) for causing turbulence in the heated airflow prior to the airflow reaching the inter-arm chamber (13), and preferably wherein the means for causing turbulence comprises an airflow mixing member (42) disposed between said means (40) for heating said airflow and said conduit (15, 17) in the or each arm.
 13. Apparatus according to any preceding claim, further comprising mutually-opposing sealing elements (48) at the distal tip of each of the first and second arms (14, 16), for preventing the escape of air past said tip.
 14. Apparatus according to any preceding claim, further comprising at least one airflow deflector (50) on the outer surface of at least one of said arms (14, 16), shaped and positioned to deflect any rearward-flowing escaping air away from the user's hand, and pref-

erably wherein said airflow deflector (50) is ramp-shaped.

15. A method of drying hair using apparatus according to any preceding claim, and preferably further comprising using the apparatus to style the hair substantially simultaneously with drying the hair.

Patentansprüche

1. Vorrichtung (10) zum Trocknen und Frisieren von Haaren, die aufweist:

einen ersten und einen zweiten Arm (14, 16), die einander gegenüberliegen, ausgelegt für die Bewegung zwischen einer offenen Stellung zum Aufnehmen eines Strangs langer Haare dazwischen und einer geschlossenen Stellung angrenzend an die Haare, so dass im Gebrauch, wenn die Arme in der geschlossenen Stellung sind, sie eine Kammer zwischen den Armen (13) bilden, über die die Haare verlaufen, und wobei eine Luftstromleitung (15, 17) innerhalb und an mindestens einem von dem ersten und dem zweiten Arm (14, 16) entlang bereitgestellt ist; ein Mittel (38) zum Zuführen eines Luftstroms entlang der Leitung (15, 17) in dem mindestens einen von dem ersten und dem zweiten Arm (14, 16) und anschließend in die Kammer zwischen den Armen (13); und

eine erste und eine zweite Platte (20a, 20b), die an dem ersten Arm (14) positioniert sind, und eine jeweilig gegenüberliegende erste und zweite Platte (22a, 22b), die an dem zweiten Arm (16) positioniert sind, wobei die einander gegenüberliegenden Platten (20a, 20b, 22a, 22b), die an dem ersten und dem zweiten Arm (14, 16) positioniert sind, so angeordnet sind, dass sie nebeneinander liegen, wenn der erste und der zweite Arm (14, 16) in der geschlossenen Stellung sind;

wobei die Kammer zwischen den Armen (13) sich zwischen den ersten und zweiten Platten (20a, 20b, 22a, 22b) des ersten und des zweiten Arms (14, 16) befindet, wenn die Arme 20 in der geschlossenen Stellung sind;

wobei mindestens eine der genannten Platten (20a, 20b, 22a, 22b) ein Mittel zum Anwenden von Wärme auf den genannten Haarstrang im Gebrauch, wenn der erste und der zweite Arm (14, 16) sich in der geschlossenen Stellung befinden, aufweist; und

wobei einer der Arme (14, 16) oder beide ferner eine Luftstromführungsstruktur (24) aufweist bzw. aufweisen, die zum Aufnehmen des Luftstroms aus der jeweiligen Leitung (15, 17) und zum Leiten des Luftstroms von einer ersten

Richtung (D1), die im Wesentlichen parallel zur Länge des jeweiligen Arms (14, 16) ist, in eine zweite Richtung (D2), die von dem jeweiligen Arm (14, 16) zu dem gegenüberliegenden Arm (16, 14) hin verläuft, in die Kammer zwischen den Armen (13) angeordnet ist.

2. Vorrichtung nach Anspruch 1, wobei die Leitung (15, 17) in dem oder jedem Arm (14, 16) als Luftkammer wirkt, durch die die Luft in die jeweilige Luftstromführungsstruktur (24) und von dort zwischen die Arme fließt, und wobei die Luftstromführungsstruktur (24) in dem oder jedem Arm (14, 16) eine zelluläre Struktur aufweist, die zum Leiten des Luftstroms von der ersten Richtung (D1) in die zweite Richtung (D2) konfiguriert ist, wobei die zelluläre Struktur eine Vielzahl von Zellwänden umfasst, die sich entlang der zweiten Richtung (D2) in die jeweilige Luftkammer erstrecken.

3. Vorrichtung nach Anspruch 2, wobei die Tiefe der Zellen in die jeweilige Luftkammer mit zunehmendem Abstand am jeweiligen Arm (14, 16) entlang nach und nach größer wird oder wobei der Durchmesser der Zellen mit zunehmendem Abstand am jeweiligen Arm (14, 16) entlang nach und nach kleiner wird.

4. Vorrichtung nach Anspruch 2 oder Anspruch 3, wobei die zelluläre Struktur eine Wabenstruktur hat.

5. Vorrichtung nach einem der Ansprüche 2 bis 4, wobei die oder jede Luftstromführungsstruktur (24) ferner eine Vielzahl von Luftstrom-umleitenden Kanälen (28) aufweist, die zum Weiterleiten des Luftstroms aus der zweiten Richtung (D2) in eine dritte und eine vierte Richtung (D3, D4), die von der Vorrichtung nach außen verlaufen, im Wesentlichen lotrecht zu der Länge der Arme (14, 16), angeordnet sind, und, vorzugsweise, wobei die Luftstrom-umleitenden Kanäle (28) sich zwischen Längsrändern und entsprechenden Längsseiten der Luftstromführungsstruktur (24) befinden.

6. Vorrichtung nach Anspruch 5, die ferner Luftstromleitungen (19a, 19b, 21a, 21b), die sich hinter den ersten und zweiten Platten (20a, 20b, 22a, 22b) des jeweiligen Arms (14, 16) erstrecken, zum Aufnehmen von Luft aus den genannten Luftstrom-umleitenden Kanälen (28) und zum Leiten des Luftstroms hinter der ersten Platte (20a, 22a) und nach außen durch Luftlöcher (26) am Rand der Vorrichtung entlang in im Wesentlichen der dritten Richtung (D3) und zum Leiten des Luftstroms hinter der zweiten Platte (20b, 22b) und nach außen durch Luftlöcher (26) am Rand der Vorrichtung entlang in im Wesentlichen der vierten Richtung (D4) aufweist.

7. Vorrichtung nach Anspruch 6, wobei die Luftstromführungsstruktur (24) die zelluläre Struktur und die Luftstrom-umleitenden Kanäle (28) aufweist und die nach außen gerichteten Luftlöcher (26) in der dritten und der vierten Richtung (D3, D4) eine einstückige Struktur sind und/oder wobei die nach außen gerichteten Luftlöcher (26) in einem Winkel von etwa 45° relativ zu der Ebene der genannten Platten (20a, 20b, 22a, 22b) ausgerichtet sind.
8. Vorrichtung nach einem der vorhergehenden Ansprüche, wobei das Mittel zum Zuführen des Luftstroms einen Ventilator (38) aufweist.
9. Vorrichtung nach einem der vorhergehenden Ansprüche, die ferner ein Mittel (40) zum Erwärmen des genannten Luftstroms aufweist.
10. Vorrichtung nach Anspruch 9, wobei das genannte Mittel zum Erwärmen des genannten Luftstroms elektrische Heizspulen (40) aufweist und, vorzugsweise, ferner einen Luftstromteiler (52) aufweist, der zum Leiten von einströmendem Luftstrom zu den genannten Heizspulen (40) hin angeordnet ist, und, vorzugsweise, wobei der Luftstromteiler (52) eine abgeschrägte oder kegelförmige Form hat.
11. Vorrichtung nach Anspruch 9 oder Anspruch 10, die ferner ein Mittel zum Durchführen von Pulsbreitenmodulation in Bezug auf elektrische Leistung, die zum Erwärmen des genannten Luftstroms auf das genannte Mittel (40) angewendet wird, aufweist.
12. Vorrichtung nach einem der Ansprüche 9 bis 11, die ferner ein Mittel (32, 42) zum Bewirken einer Verwirbelung in dem erwärmten Luftstrom, bevor der Luftstrom die Kammer zwischen den Armen (13) erreicht, aufweist und, vorzugsweise, wobei das Mittel zum Bewirken einer Verwirbelung ein Luftstrommischelement (42) aufweist, das zwischen dem genannten Mittel (40) zum Erwärmen des genannten Luftstroms und der genannten Leitung (15, 17) in dem oder jedem Arm positioniert ist.
13. Vorrichtung nach einem der vorhergehenden Ansprüche, die ferner einander gegenüberliegende Dichtelemente (48) an der distalen Spitze von jedem des ersten und des zweiten Arms (14, 16) zum Verhindern des Entweichens von Luft an der genannten Spitze vorbei aufweist.
14. Vorrichtung nach einem der vorhergehenden Ansprüche, die ferner wenigstens einen Luftstromabweiser (50) an der Außenfläche von wenigstens einem der genannten Arme (14, 16) aufweist, der so geformt und positioniert ist, dass er nach hinten strömende entweichende Luft von der Hand des Benutzers weg abweist, und, vorzugsweise, wobei der ge-

nannte Luftstromabweiser (50) rampenförmig ist.

15. Verfahren zum Trocknen von Haaren unter Verwendung der Vorrichtung nach einem der vorhergehenden Ansprüche und das vorzugsweise ferner das Verwenden der Vorrichtung zum Frisieren der Haare im Wesentlichen gleichzeitig mit dem Trocknen der Haare aufweist.

Revendications

1. Appareil (10) pour sécher et coiffer les cheveux, comprenant :

des premier et second bras (14, 16) mutuellement opposés, conçus pour se déplacer entre une configuration ouverte pour recevoir une longueur de cheveux mouillés et une configuration fermée adjacente aux cheveux, de telle sorte que, lors de l'utilisation, lorsqu'ils sont dans la configuration fermée, les bras forment une chambre inter-bras (13) par laquelle les cheveux passent, un conduit d'écoulement d'air (15, 17) étant situé à l'intérieur et le long d'au moins un des premier et second bras (14, 16) ; un moyen (38) permettant de délivrer un écoulement d'air le long du conduit (15, 17) dans l'au moins un des premier et second bras (14, 16), puis dans la chambre inter-bras (13) ; et des première et seconde plaques (20a, 20b) disposées sur le premier bras (14) et des première et seconde plaques (22a, 22b) opposées respectives disposées sur le second bras (16), les plaques opposées (20a, 20b, 22a, 22b) disposées sur les premier et second bras (14, 16) étant agencées pour se rejoindre lorsque les premier et second bras (14, 16) sont dans la configuration fermée ; la chambre inter-bras (13) étant située entre les première et seconde plaques (20a, 20b, 22a, 22b) des premier et second bras (14, 16) lorsque les bras sont dans la configuration fermée ; au moins une desdites plaques (20a, 20b, 22a, 22b) comprenant un moyen permettant d'appliquer de la chaleur à ladite longueur de cheveux lors de l'utilisation, lorsque les premier et second bras (14, 16) sont dans la configuration fermée ; et un ou deux des bras (14, 16) comprenant en outre une structure de guidage d'écoulement d'air (24) conçue pour recevoir l'écoulement d'air en provenance du conduit (15, 17) respectif et pour diriger l'écoulement d'air d'une première direction (D1) qui est sensiblement parallèle à la longueur du bras (14, 16) respectif vers une deuxième direction (D2) qui va du bras (14, 16) respectif vers le bras opposé (16, 14), dans la

- chambre inter-bras (13).
2. Appareil selon la revendication 1, dans lequel le conduit (15, 17) dans le ou chaque bras (14, 16) agit comme une chambre de plénum par laquelle l'air s'écoule dans la structure de guidage d'écoulement d'air (24) respective et de là dans l'inter-bras, et dans lequel la structure de guidage d'écoulement d'air (24) dans le ou chaque bras (14, 16) comprend une structure cellulaire configurée pour diriger l'écoulement d'air de la première direction (D1) vers la deuxième direction (D2), la structure cellulaire comprenant une pluralité de parois cellulaires qui s'étendent le long de la deuxième direction (D2) dans la chambre de plénum respective.
 3. Appareil selon la revendication 2, dans lequel la profondeur des cellules dans la chambre de plénum respective augmente progressivement avec la distance le long du bras (14, 16) respectif, ou dans lequel le diamètre des cellules diminue progressivement avec la distance le long du bras (14, 16) respectif.
 4. Appareil selon la revendication 2 ou 3, dans lequel la structure cellulaire a une structure en nid d'abeille.
 5. Appareil selon l'une quelconque des revendications 2 à 4, dans lequel la ou chaque structure de guidage d'écoulement d'air (24) comprend en outre une pluralité de canaux de redirection d'écoulement d'air (28) configurés pour acheminer l'écoulement d'air de la deuxième direction (D2) vers des troisième et quatrième directions (D3, D4) qui sont dirigées vers l'extérieur de l'appareil, sensiblement perpendiculaires à la longueur des bras (14, 16), les canaux de redirection d'écoulement d'air (28) s'étendant de préférence entre des bords longitudinaux et des côtés longitudinaux correspondants de la structure de guidage d'écoulement d'air (24).
 6. Appareil selon la revendication 5, comprenant en outre des conduits d'écoulement d'air (19a, 19b, 21a, 21b) qui s'étendent derrière les première et seconde plaques (20a, 20b, 22a, 22b) du bras (14, 16) respectif, agencés pour recevoir de l'air en provenance desdits canaux de redirection d'écoulement d'air (28), pour diriger l'écoulement d'air derrière la première plaque (20a, 22a) et vers l'extérieur par des événements (26) le long du bord de l'appareil dans sensiblement la troisième direction (D3) et pour diriger l'écoulement d'air derrière la seconde plaque (20b, 22b) et vers l'extérieur par les événements (26) le long du bord de l'appareil dans sensiblement la quatrième direction (D4).
 7. Appareil selon la revendication 6, dans lequel la structure de guidage d'écoulement d'air (24), comprenant la structure cellulaire et les canaux de redirection d'écoulement d'air (28), ainsi que les événements (26) vers l'extérieur dans les troisième et quatrième directions (D3, D4) constituent une structure unitaire, et/ou dans lequel les événements (26) vers l'extérieur sont orientés à un angle d'environ 45° par rapport au plan desdites plaques (20a, 20b, 22a, 22b).
 8. Appareil selon l'une quelconque des revendications précédentes, dans lequel le moyen permettant de délivrer l'écoulement d'air comprend un ventilateur (38).
 9. Appareil selon l'une quelconque des revendications précédentes, comprenant en outre un moyen (40) permettant de chauffer ledit écoulement d'air.
 10. Appareil selon la revendication 9, dans lequel ledit moyen permettant de chauffer ledit écoulement d'air comprend des serpentins de chauffage électriques (40), et comprenant de préférence en outre un répartiteur d'écoulement d'air (52) agencé pour diriger l'écoulement d'air entrant vers lesdits serpentins de chauffage (40), le répartiteur d'écoulement d'air (52) étant de préférence de forme conique ou effilée.
 11. Appareil selon la revendication 9 ou 10, comprenant en outre un moyen permettant d'effectuer une modulation d'impulsions en largeur en ce qui concerne la puissance électrique appliquée audit moyen (40) permettant de chauffer ledit écoulement d'air.
 12. Appareil selon l'une quelconque des revendications 9 à 11, comprenant en outre un moyen (32, 42) permettant de provoquer des turbulences dans l'écoulement d'air chauffé avant que l'écoulement d'air n'atteigne la chambre inter-bras (13), le moyen permettant de provoquer des turbulences comprenant de préférence un élément de mélange d'écoulement d'air (42) disposé entre ledit moyen (40) permettant de chauffer ledit écoulement d'air et ledit conduit (15, 17) dans le ou chaque bras.
 13. Appareil selon l'une quelconque des revendications précédentes, comprenant en outre des éléments d'étanchéité (48) s'opposant mutuellement au niveau de l'extrémité distale de chacun des premier et second bras (14, 16) pour limiter l'échappement de l'air au-delà de ladite extrémité.
 14. Appareil selon l'une quelconque des revendications précédentes, comprenant en outre au moins un déflecteur d'écoulement d'air (50) sur la surface extérieure d'au moins un desdits bras (14, 16), façonné et positionné de manière à dévier de la main de l'utilisateur tout air s'échappant vers l'arrière, ledit déflecteur d'écoulement d'air (50) ayant de préférence la forme d'une rampe.

15. Procédé permettant de sécher les cheveux au moyen d'un appareil selon l'une quelconque des revendications précédentes, et de préférence consistant en outre à utiliser l'appareil pour coiffer les cheveux de manière sensiblement simultanée au séchage des cheveux. 5

10

15

20

25

30

35

40

45

50

55

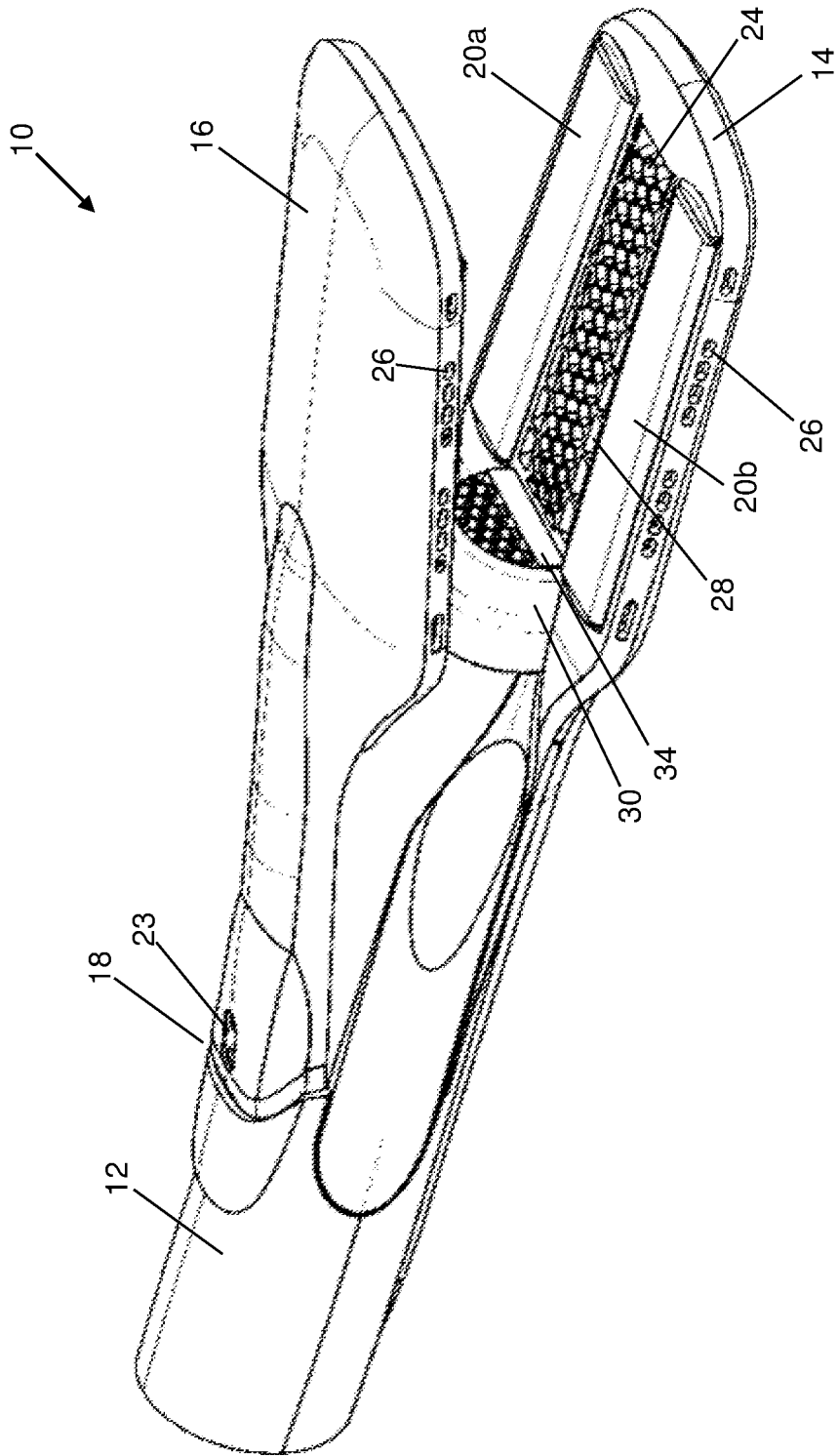

Figure 1

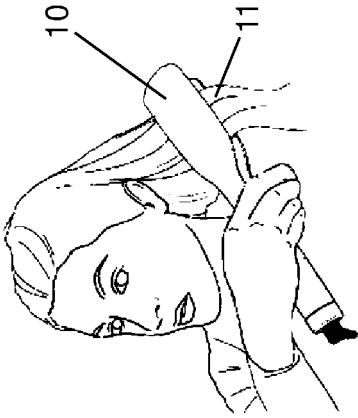

Figure 3

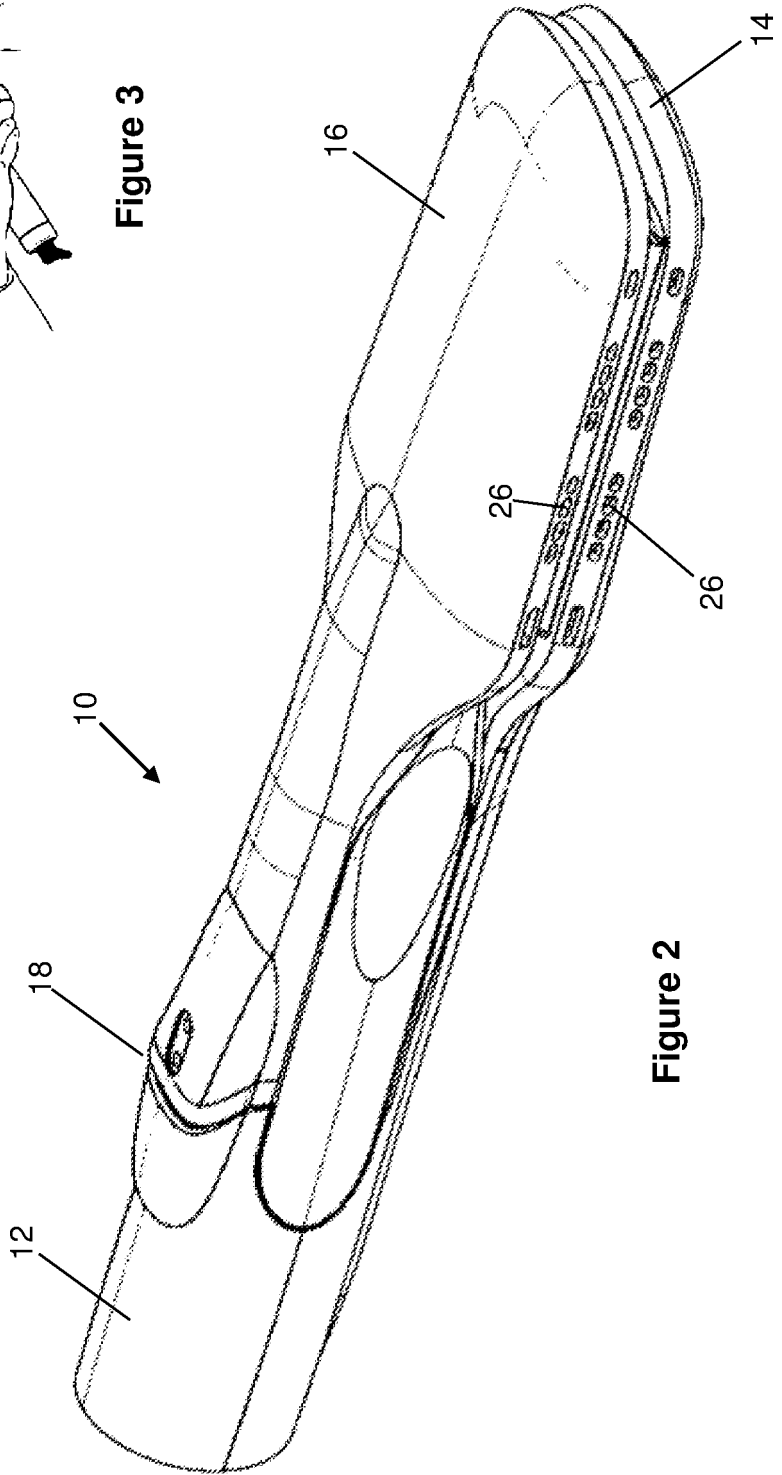

Figure 2

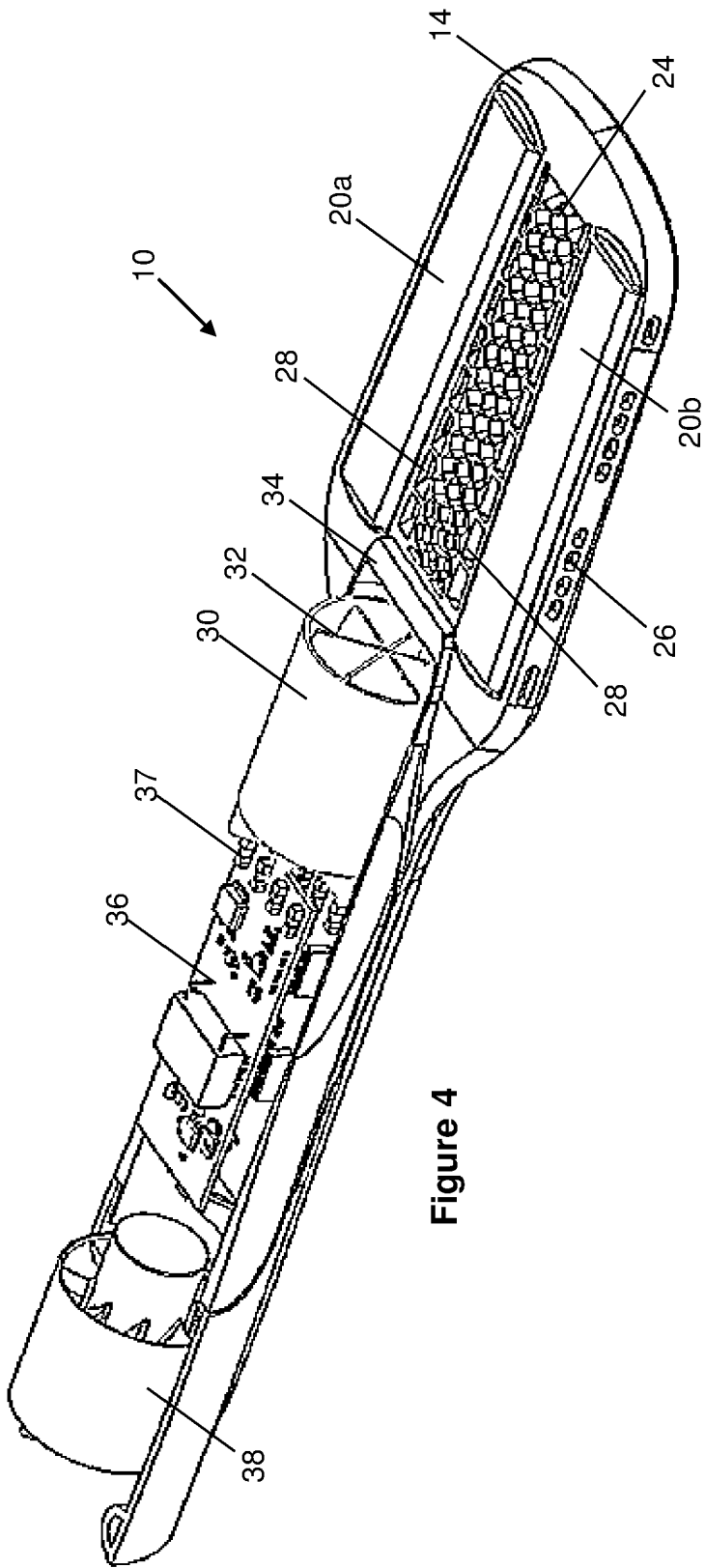

Figure 4

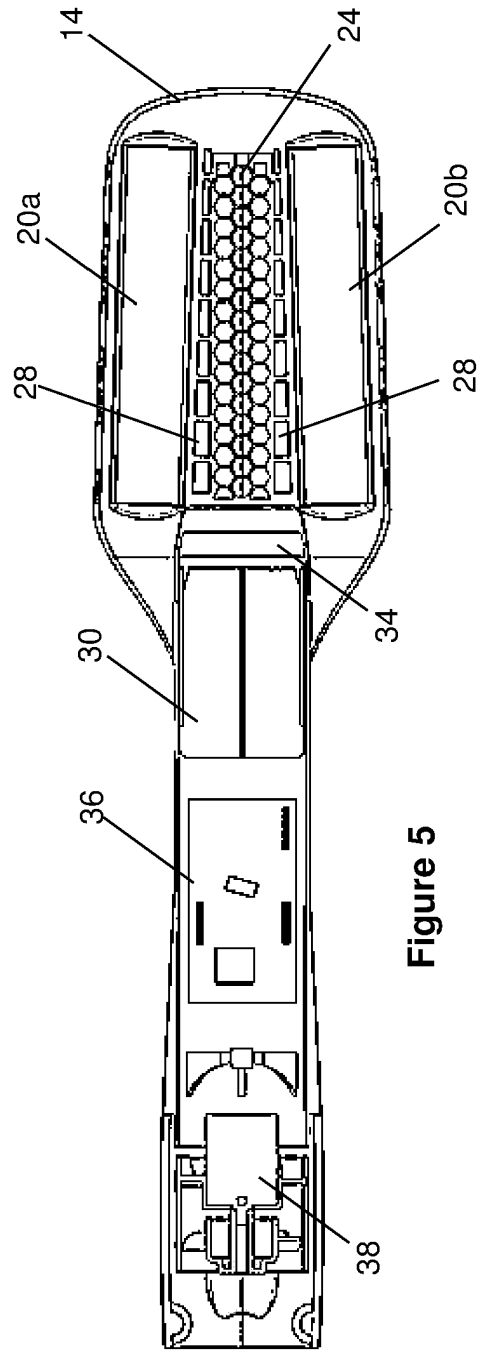

Figure 5

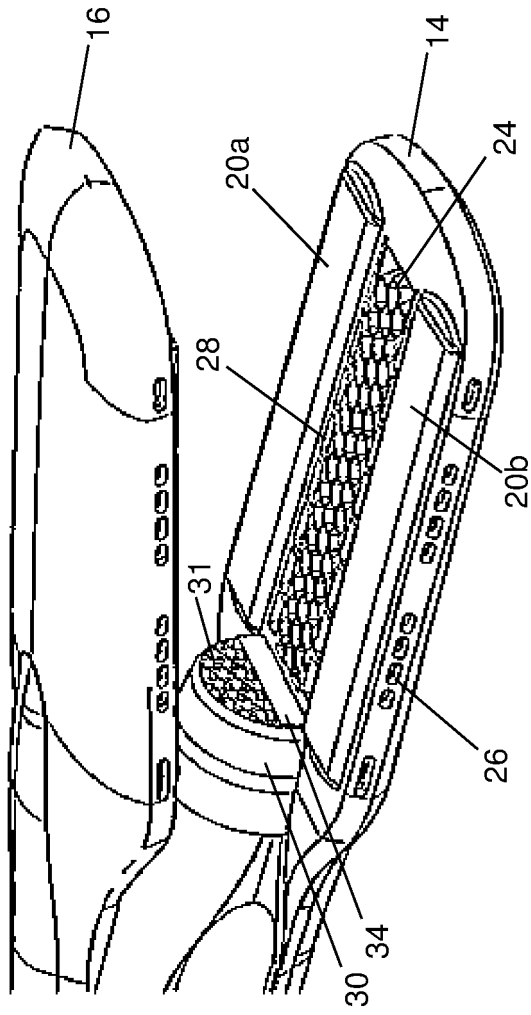

Figure 6

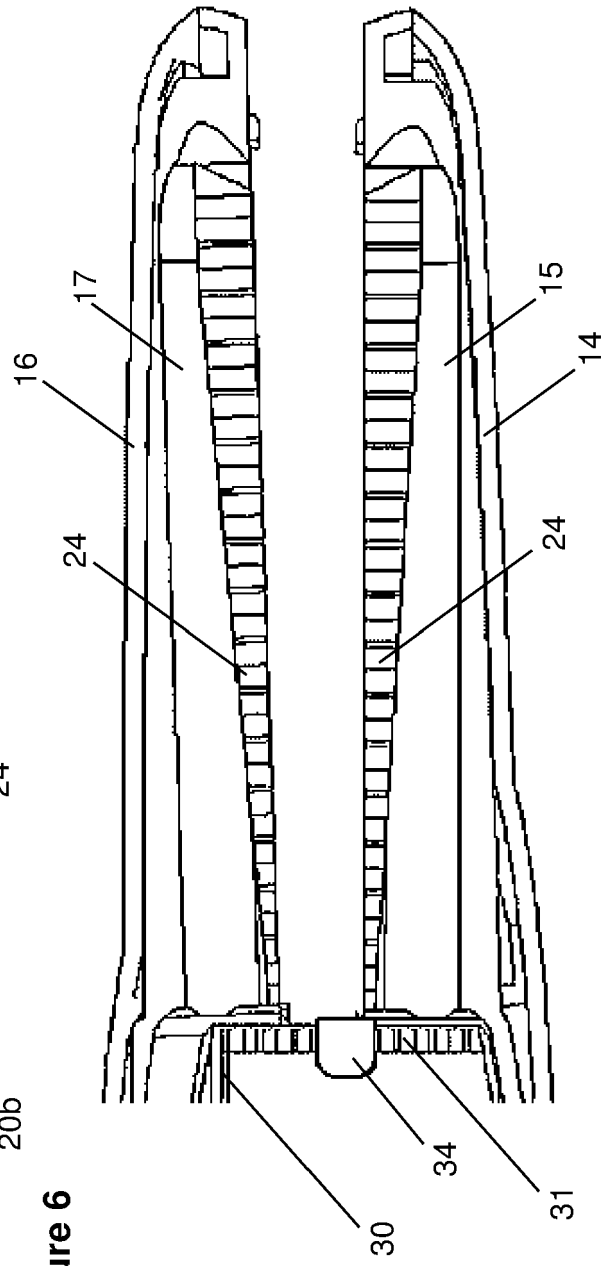

Figure 7

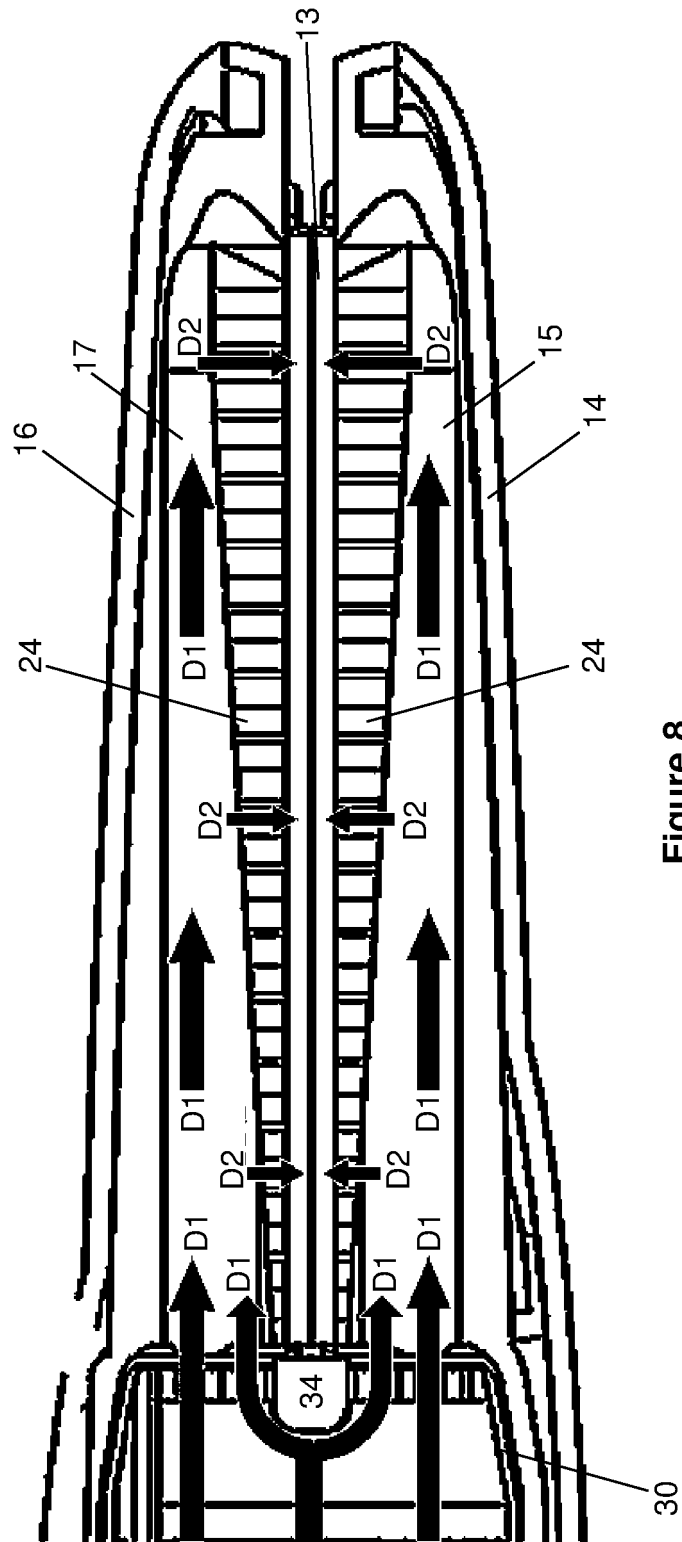

Figure 8

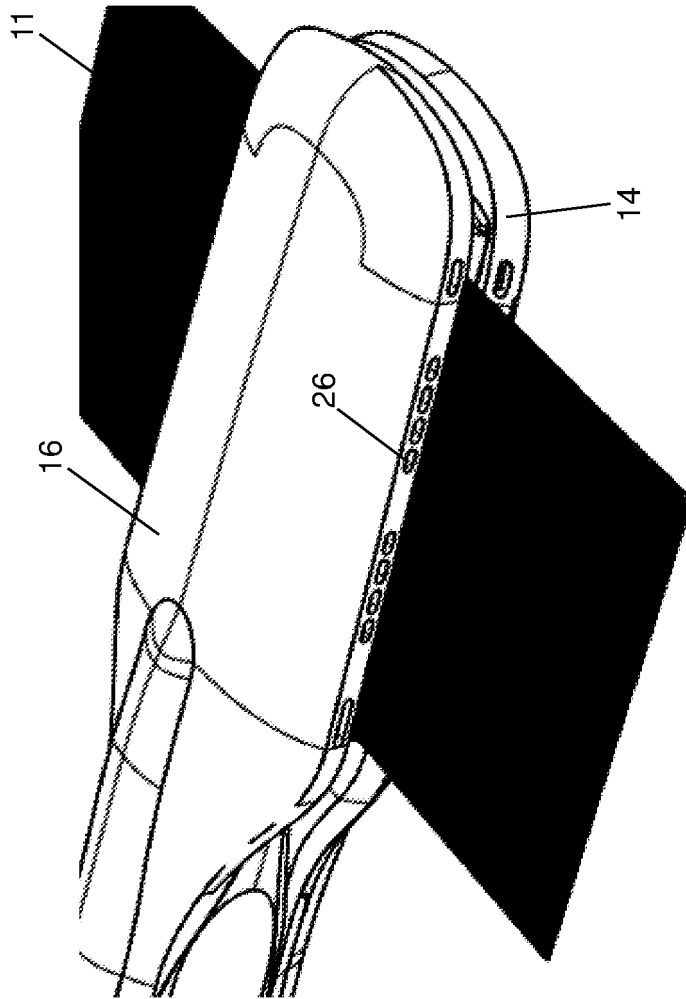

Figure 9

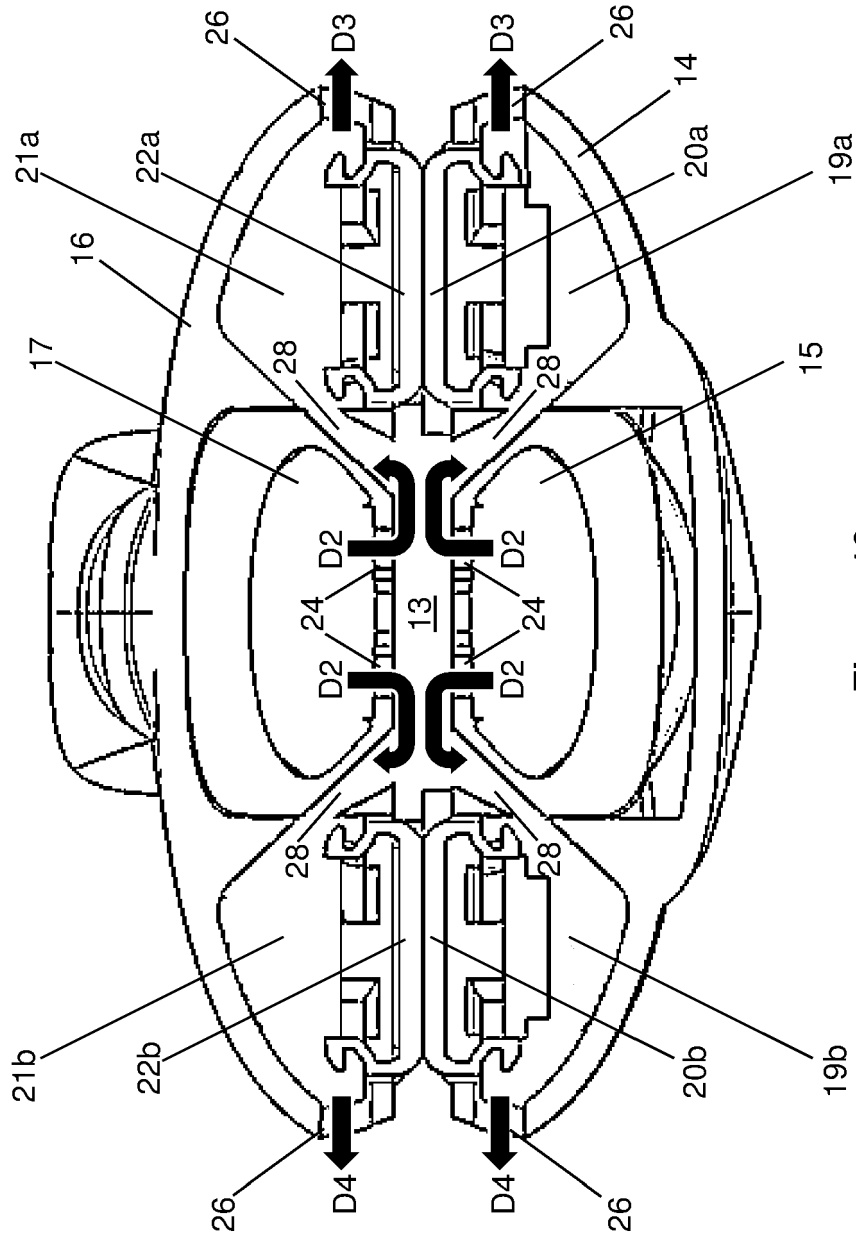

Figure 10

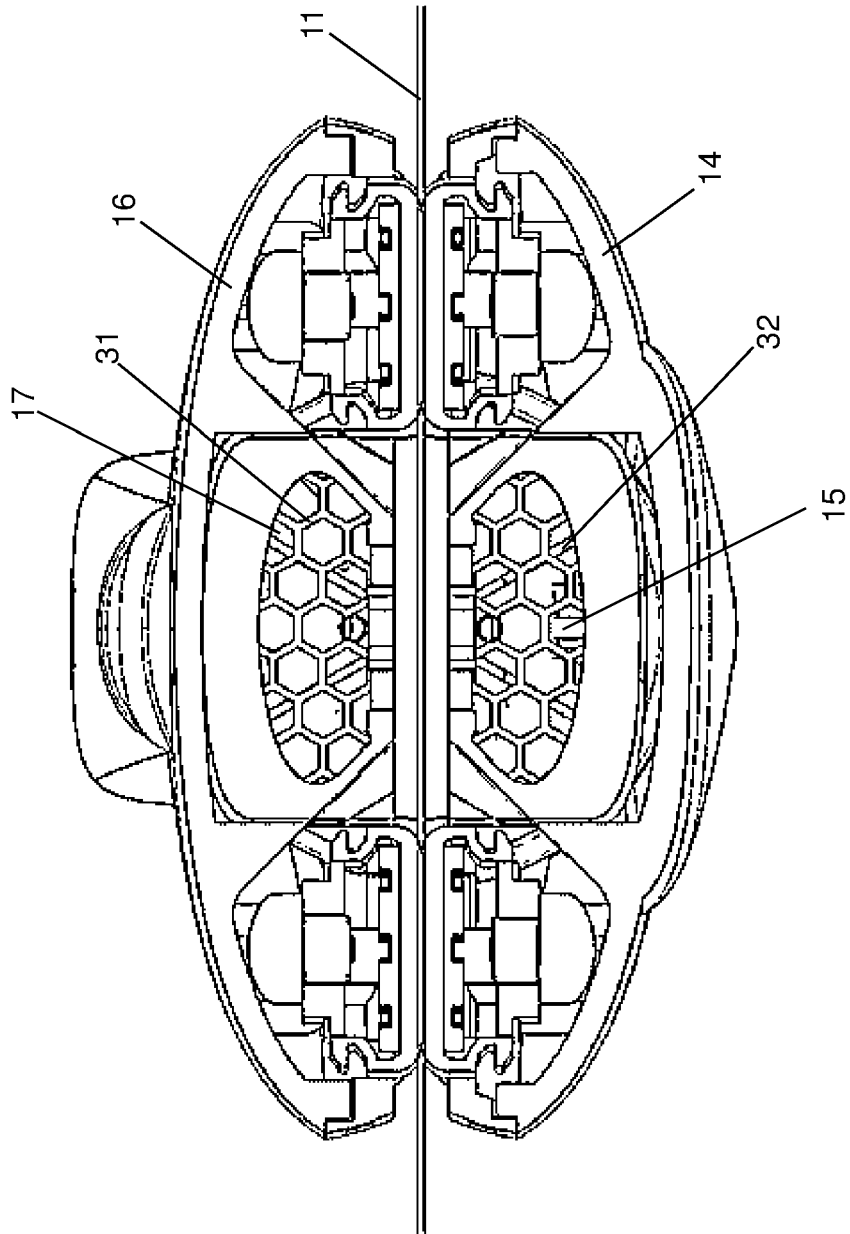

Figure 11

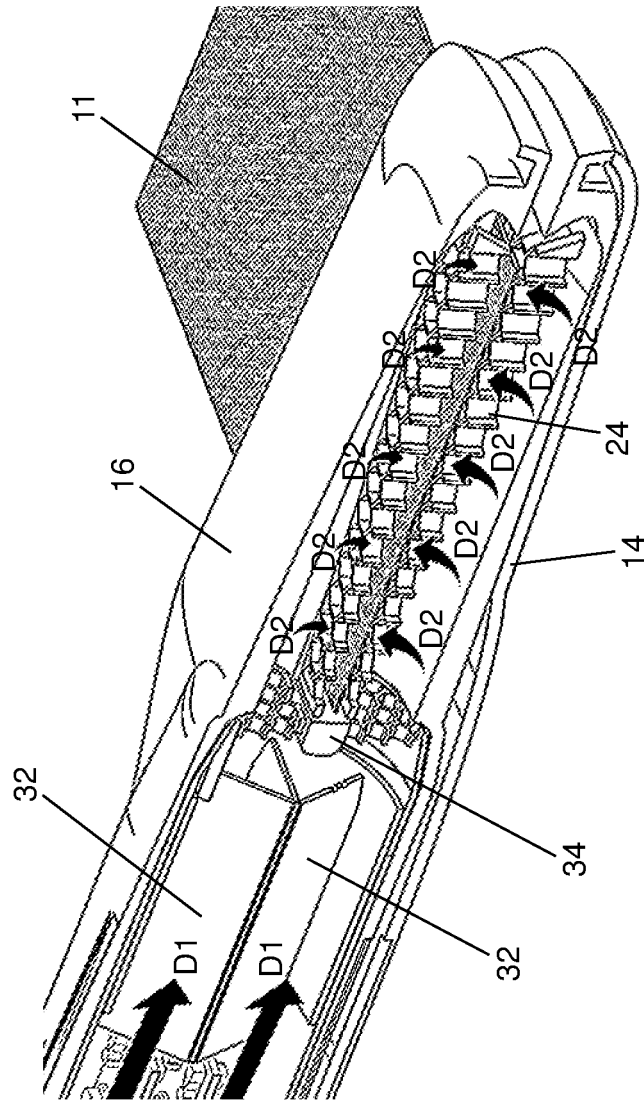

Figure 12

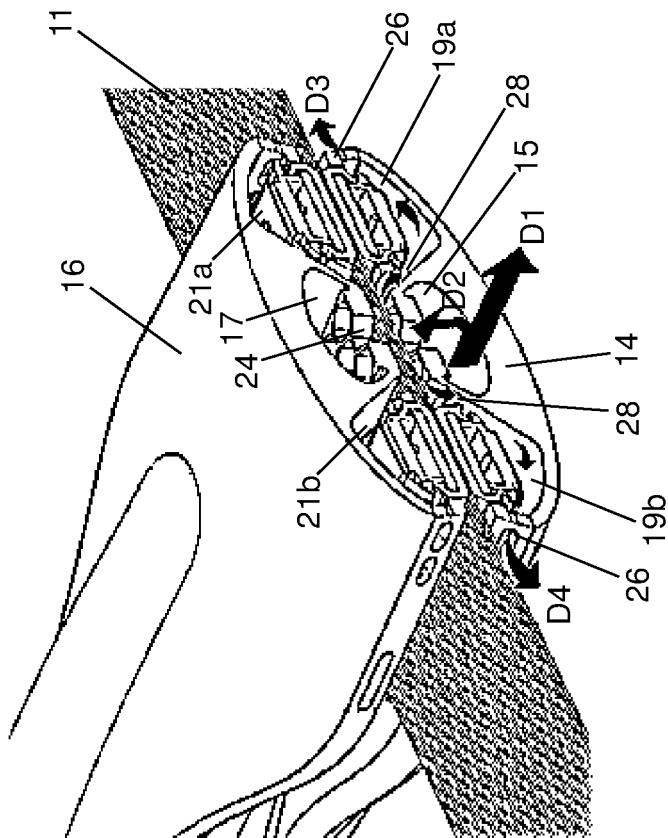

Figure 13

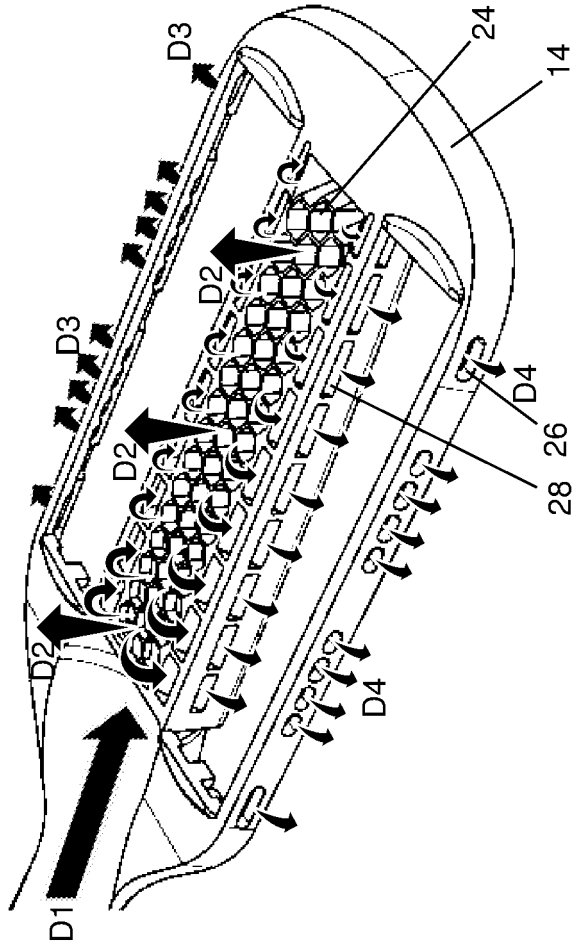

Figure 14

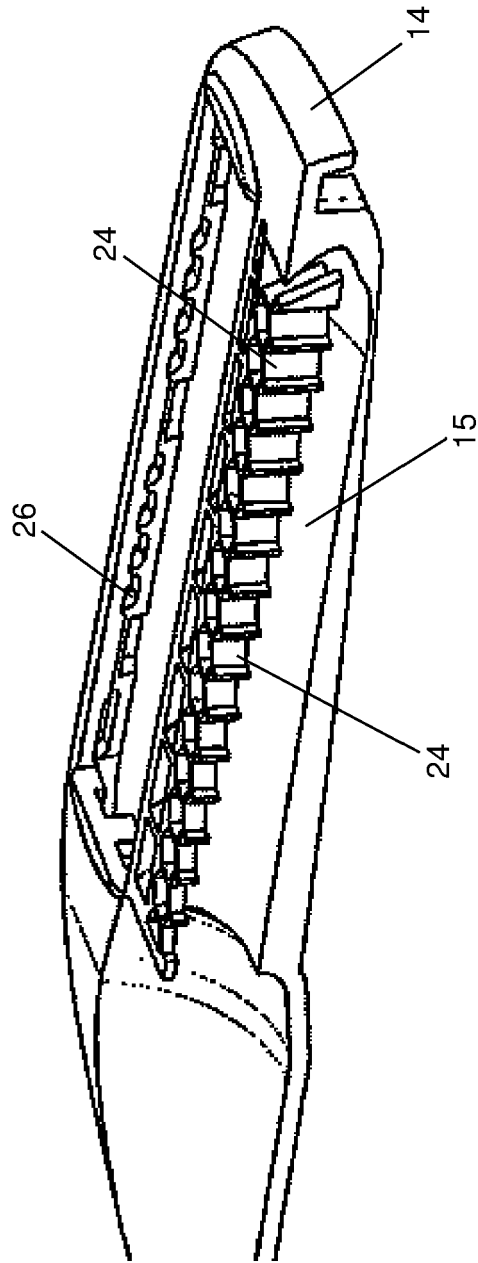

Figure 15

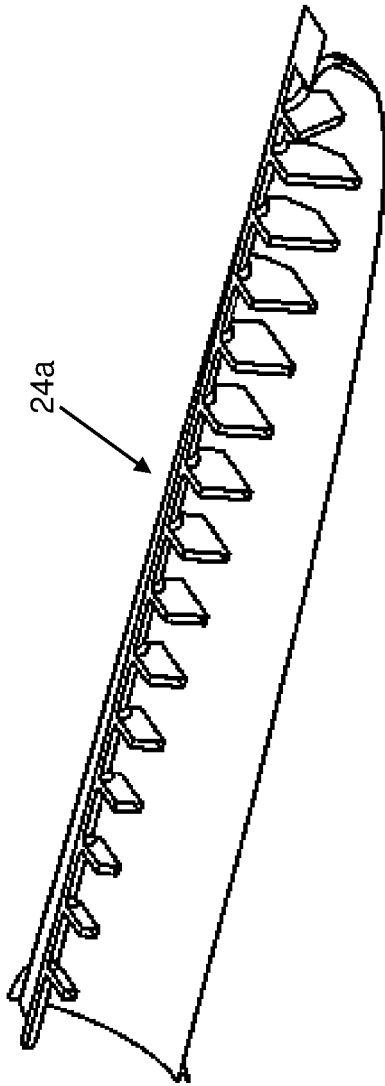

Figure 16

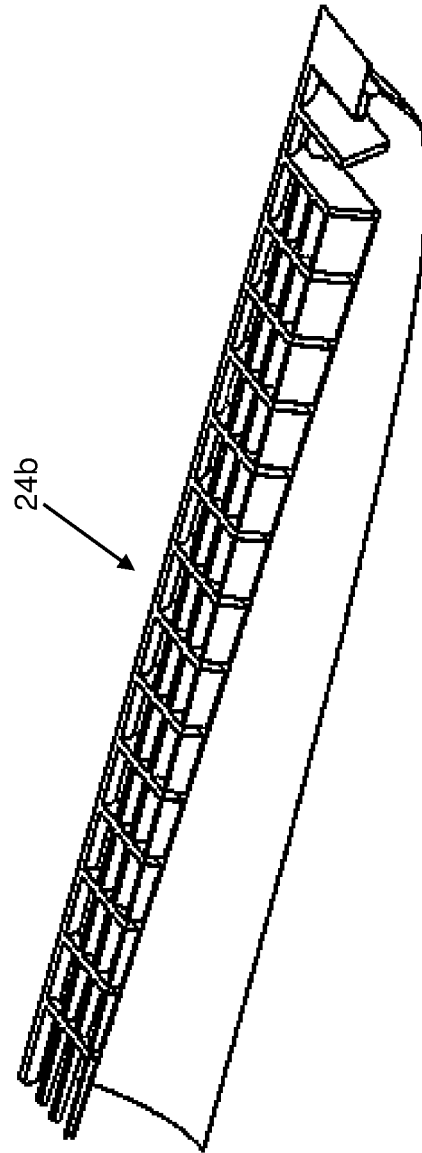

Figure 17

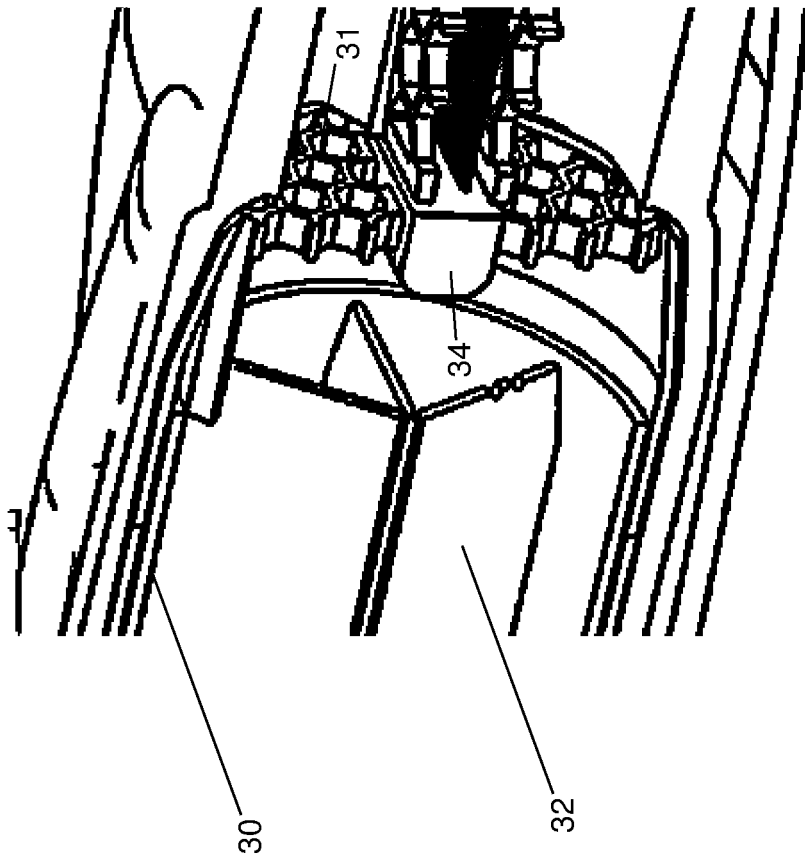

Figure 18

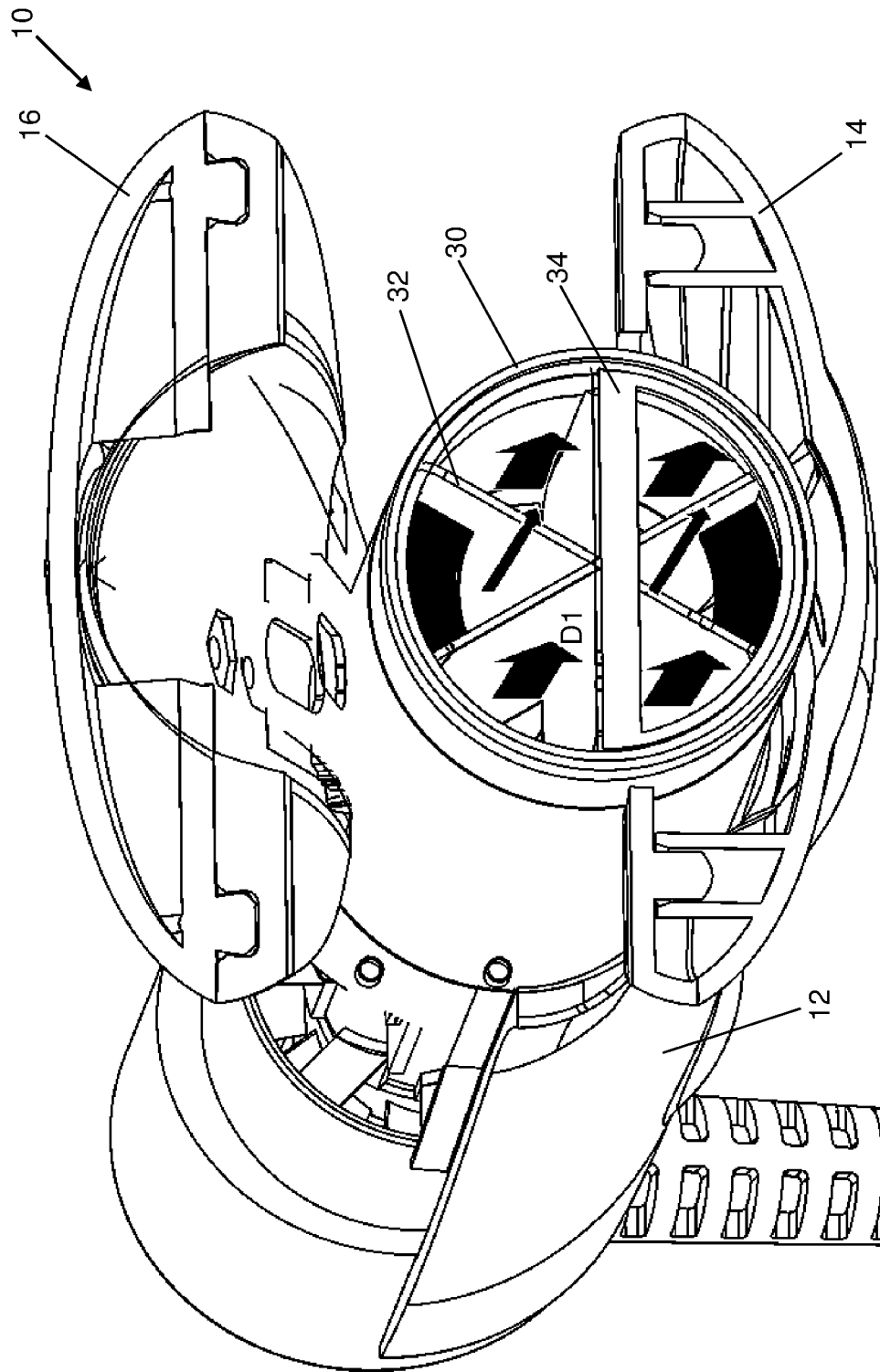

Figure 19

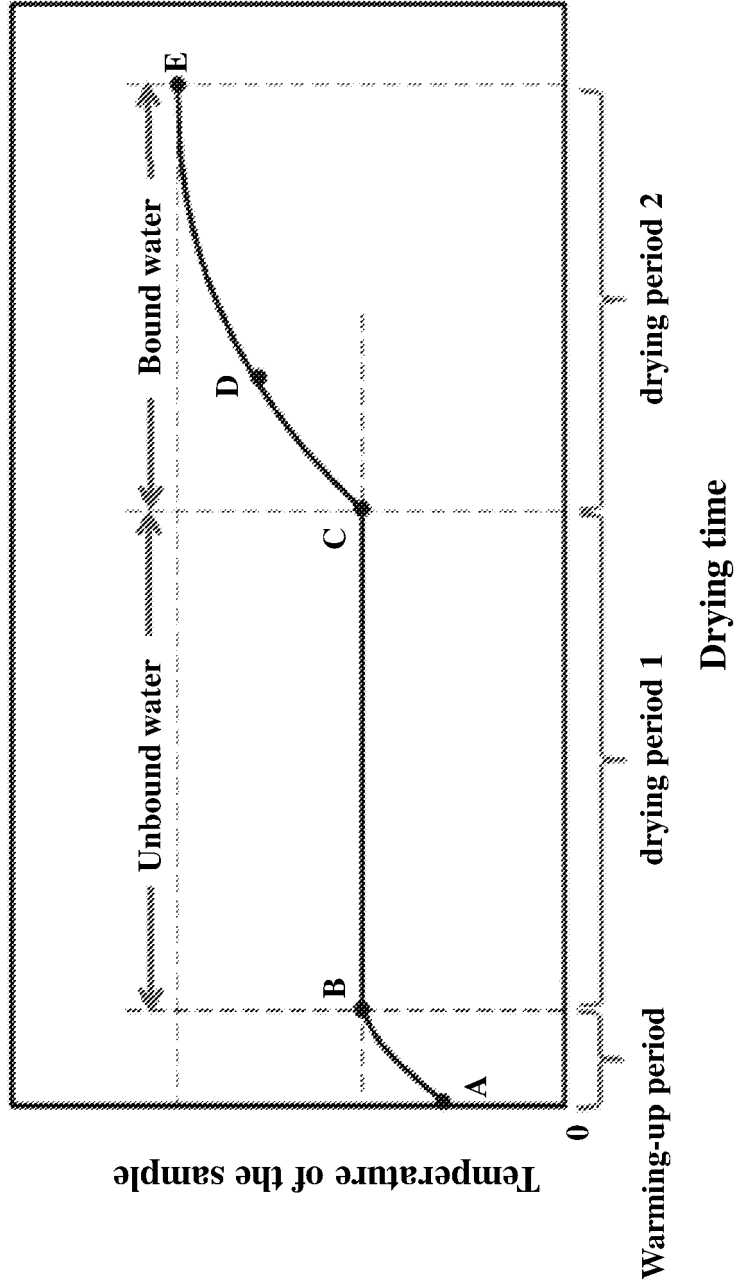

Figure 20

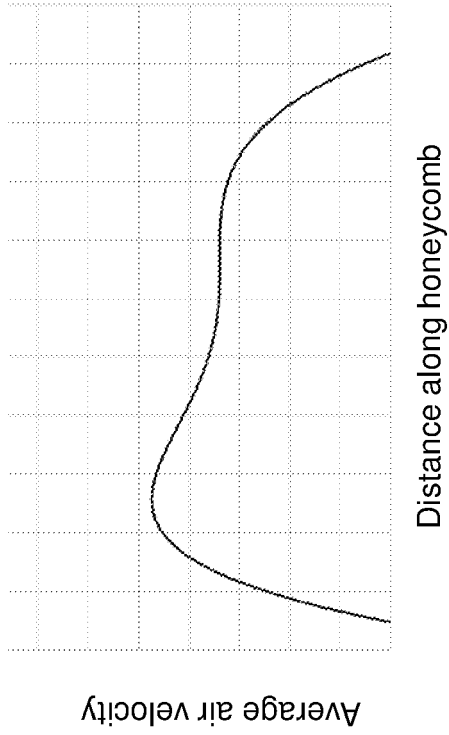

Figure 22

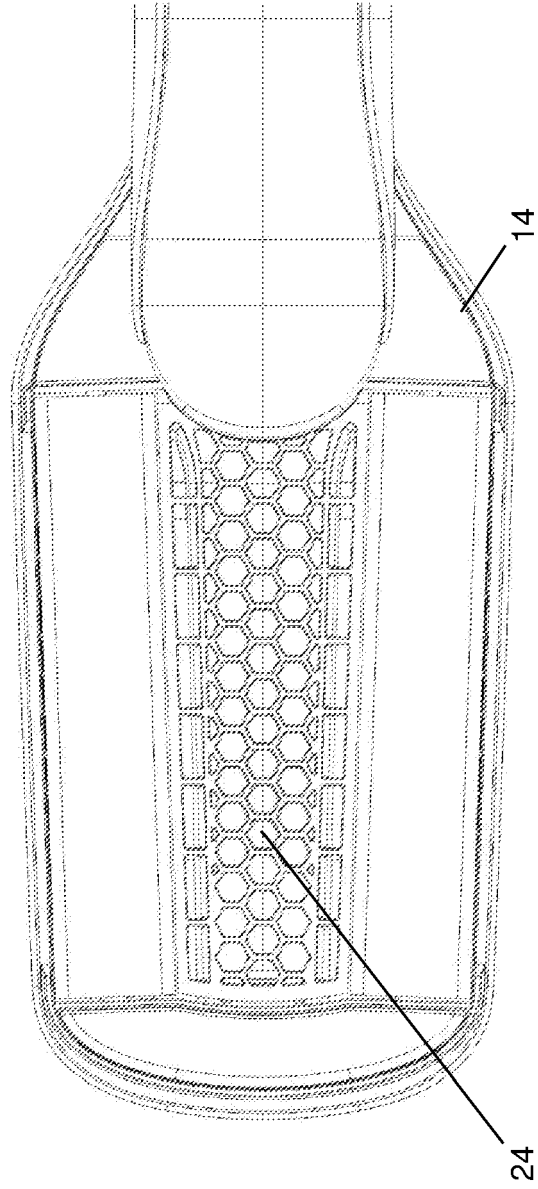

Figure 21

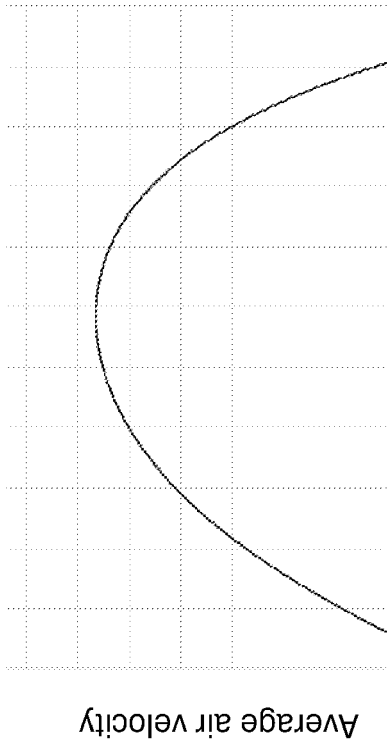

Figure 24

Distance along honeycomb

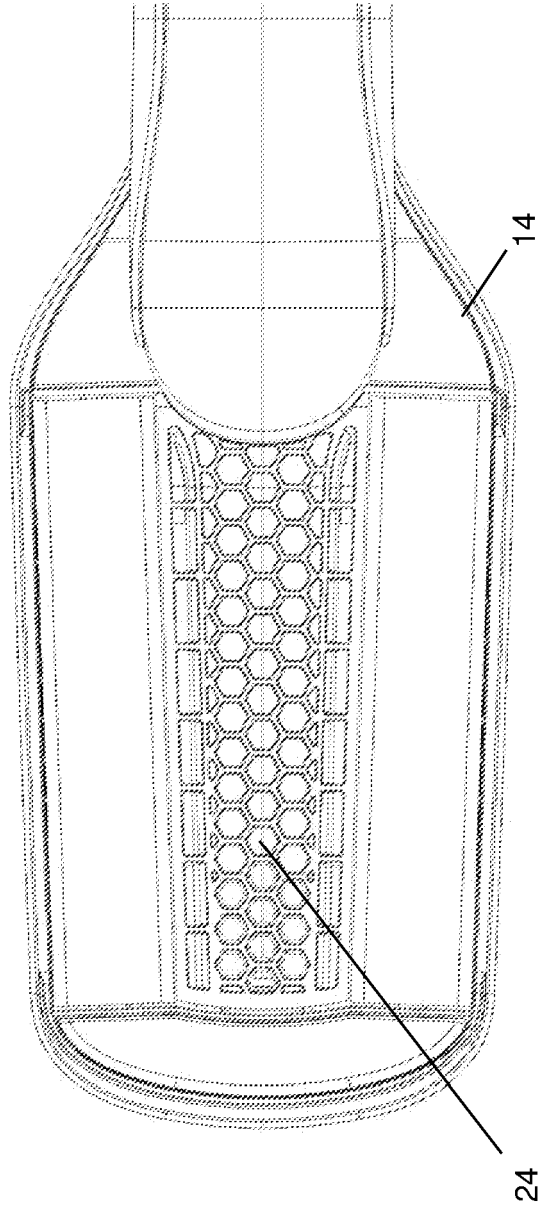

Figure 23

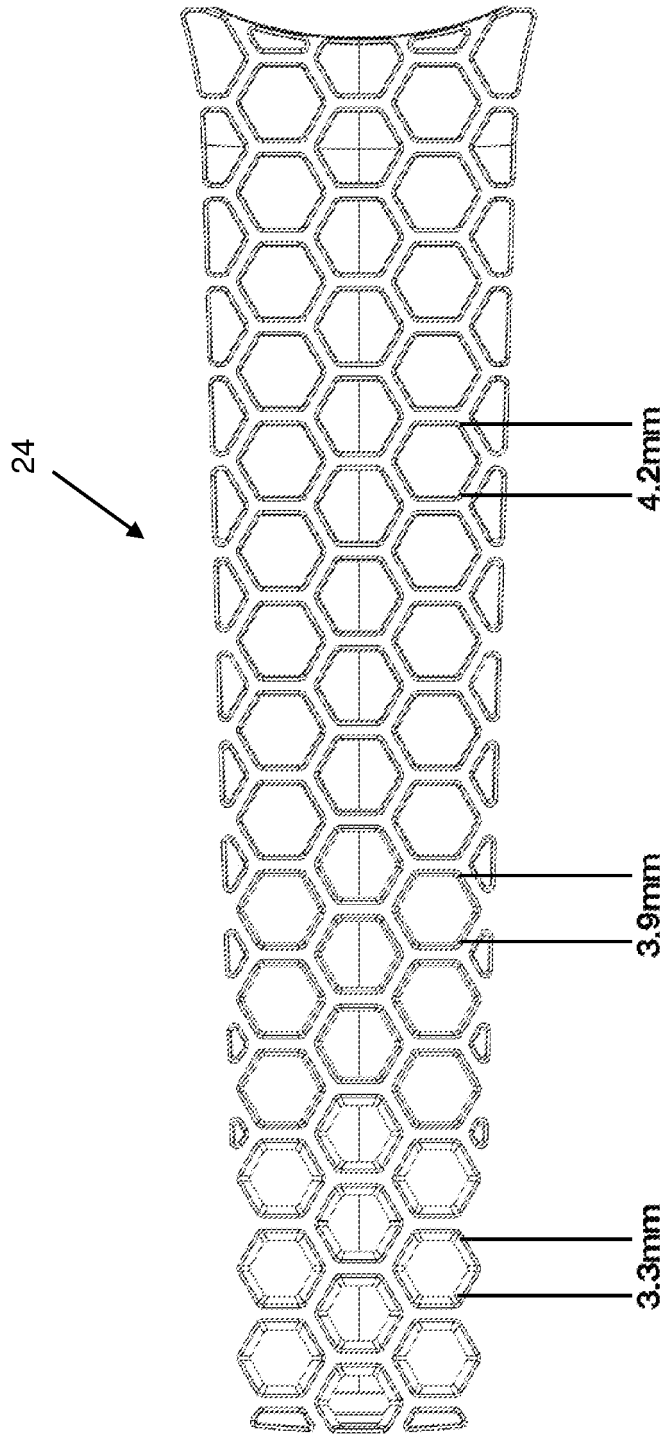

Figure 25

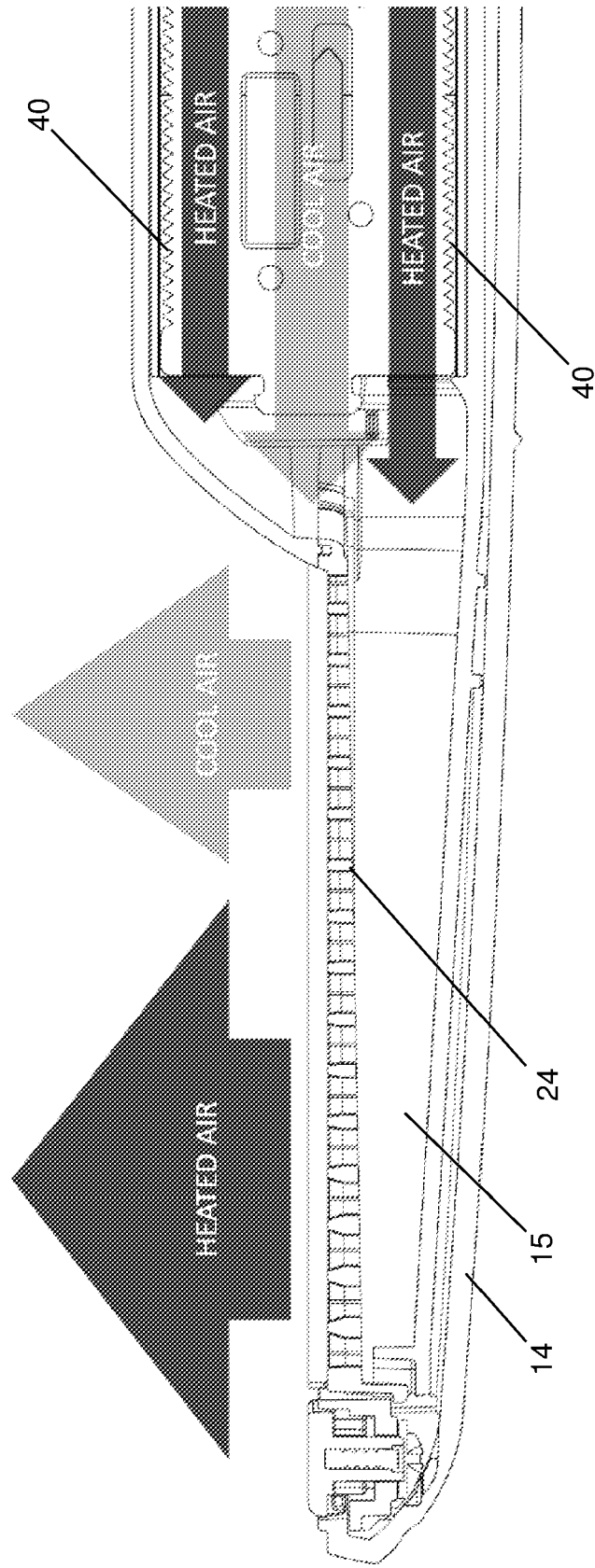

Figure 26

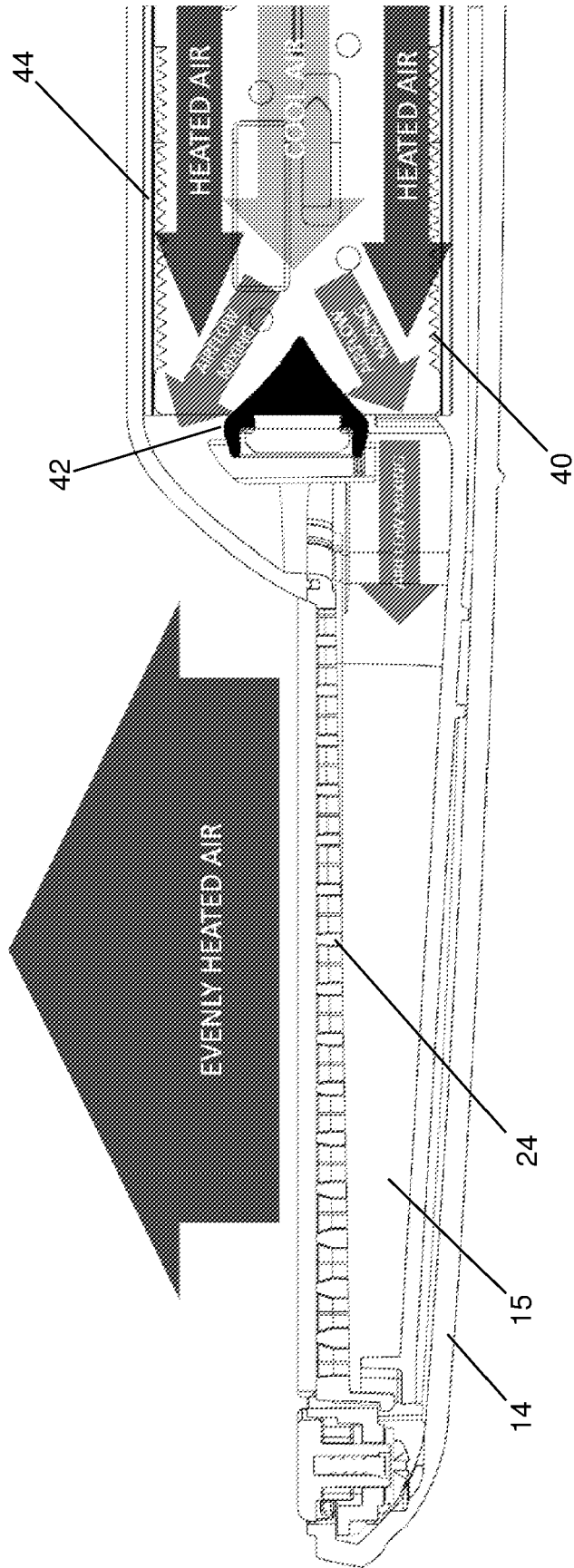

Figure 27

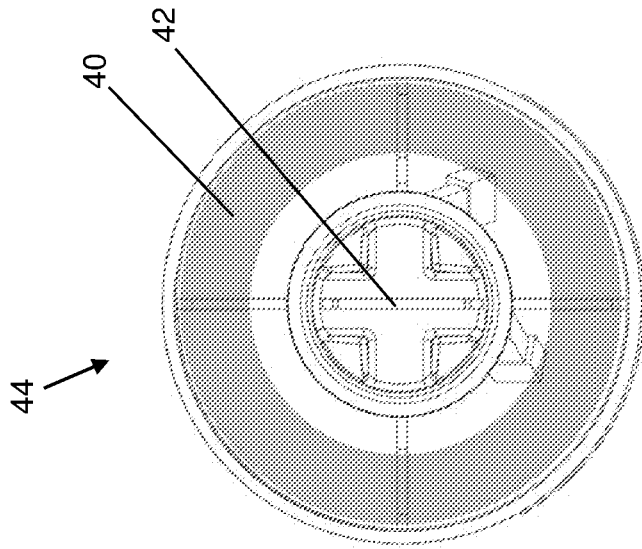

Figure 29

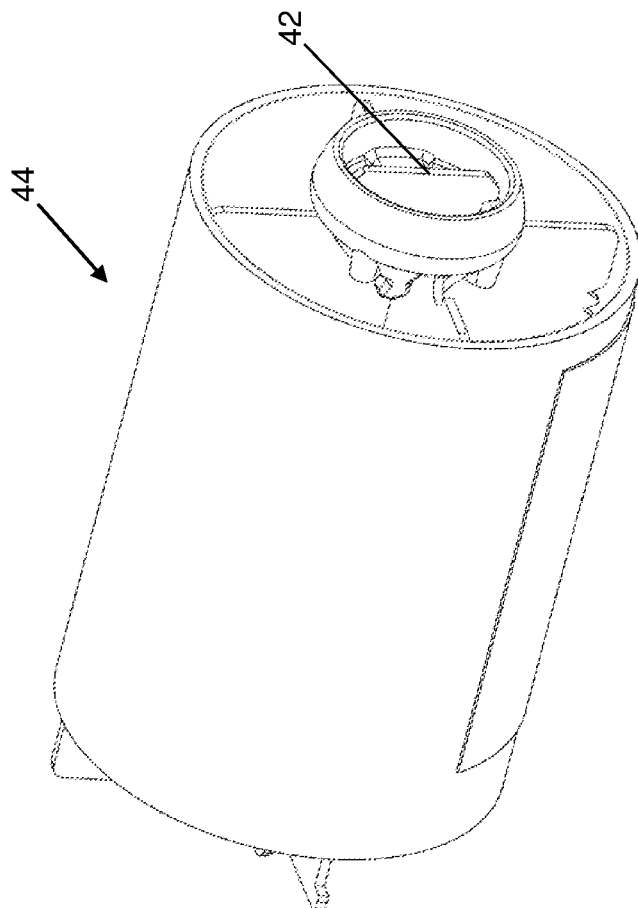

Figure 28

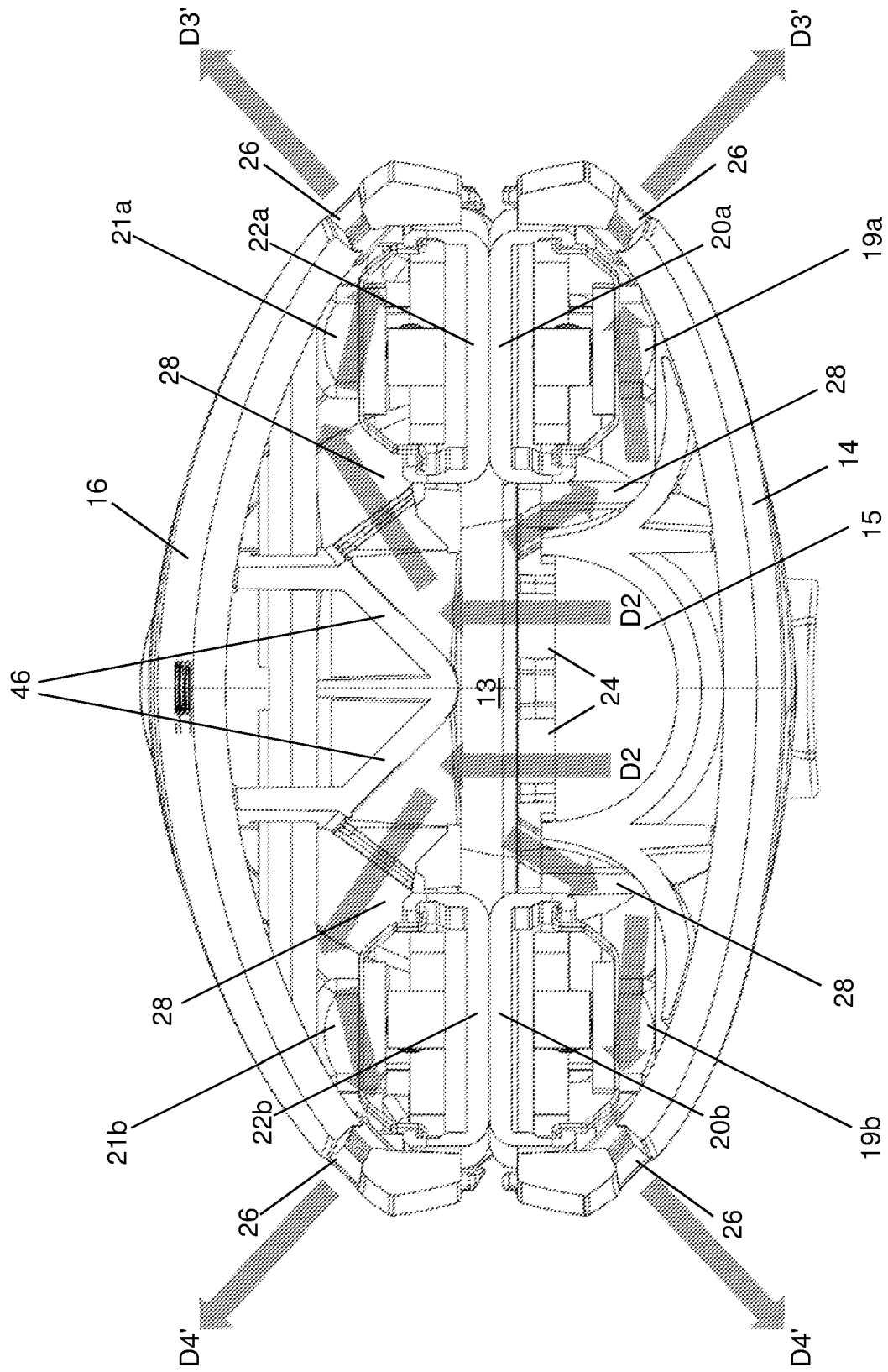

Figure 30

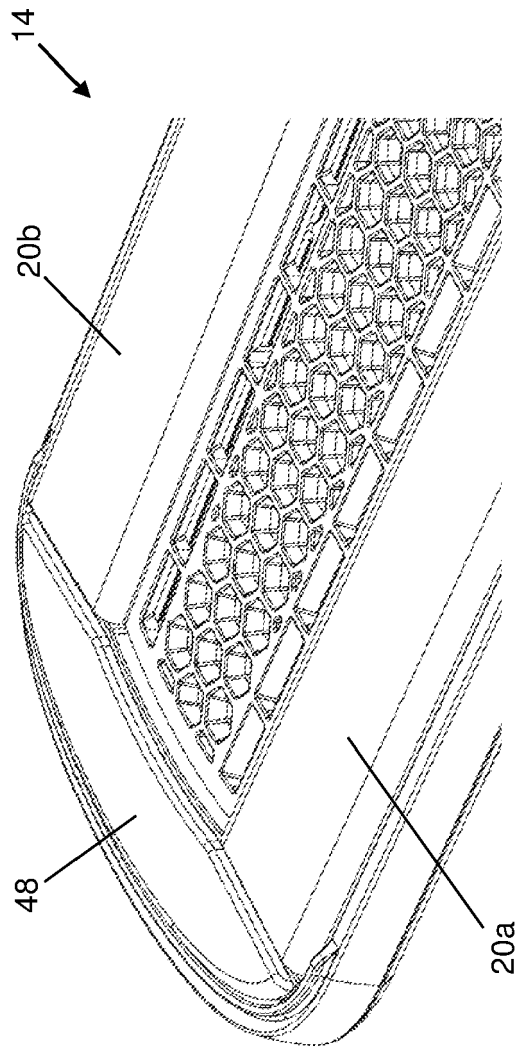

Figure 31

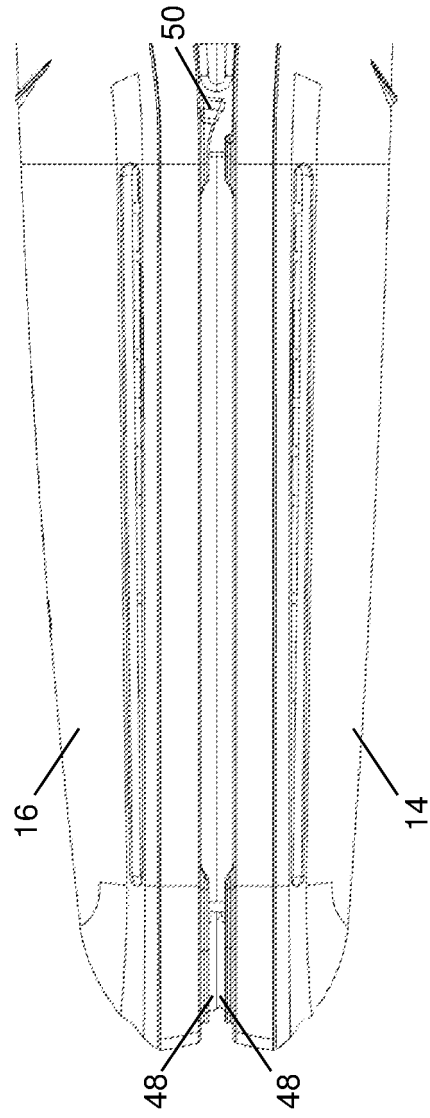

Figure 32

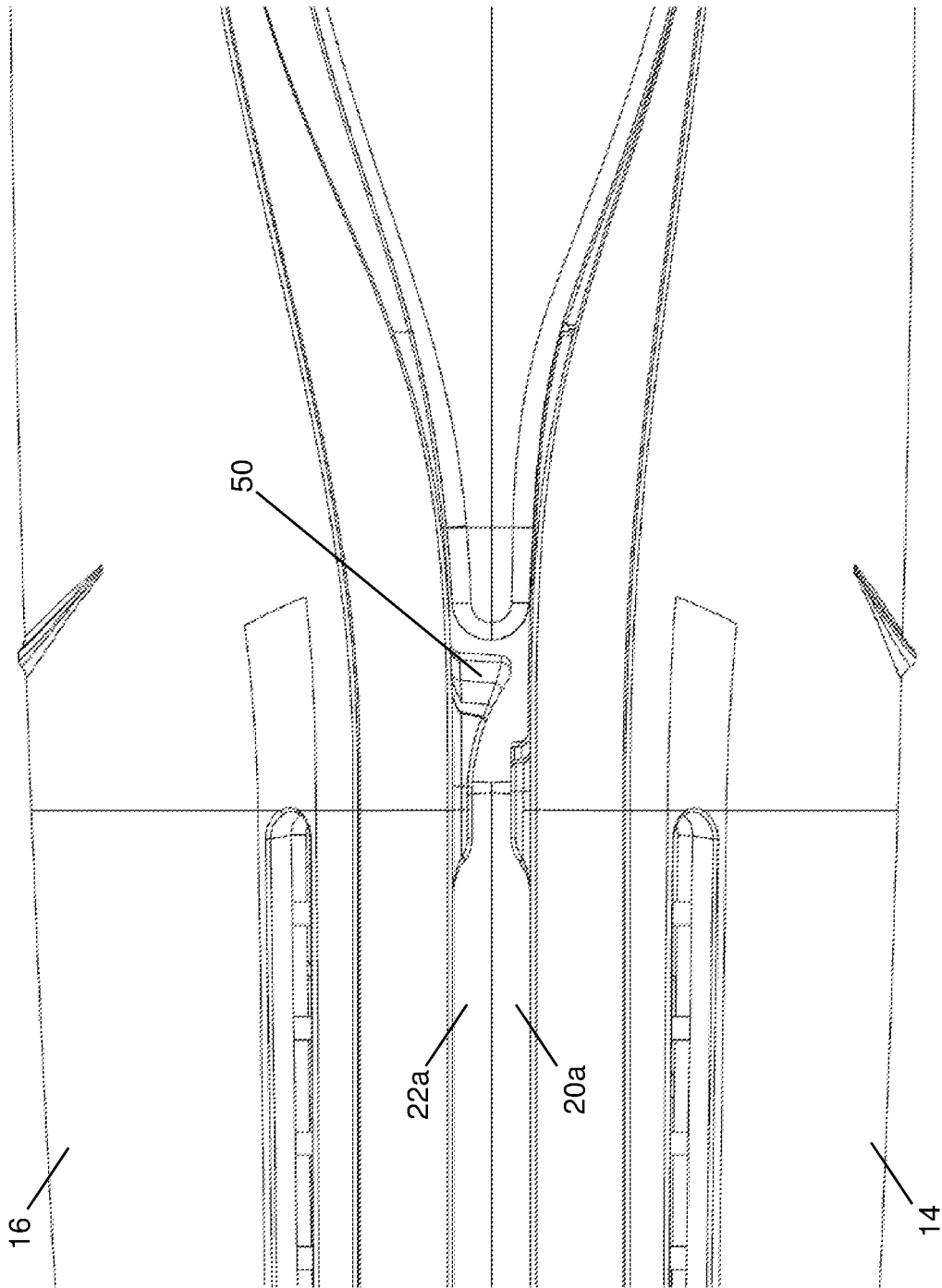

Figure 33

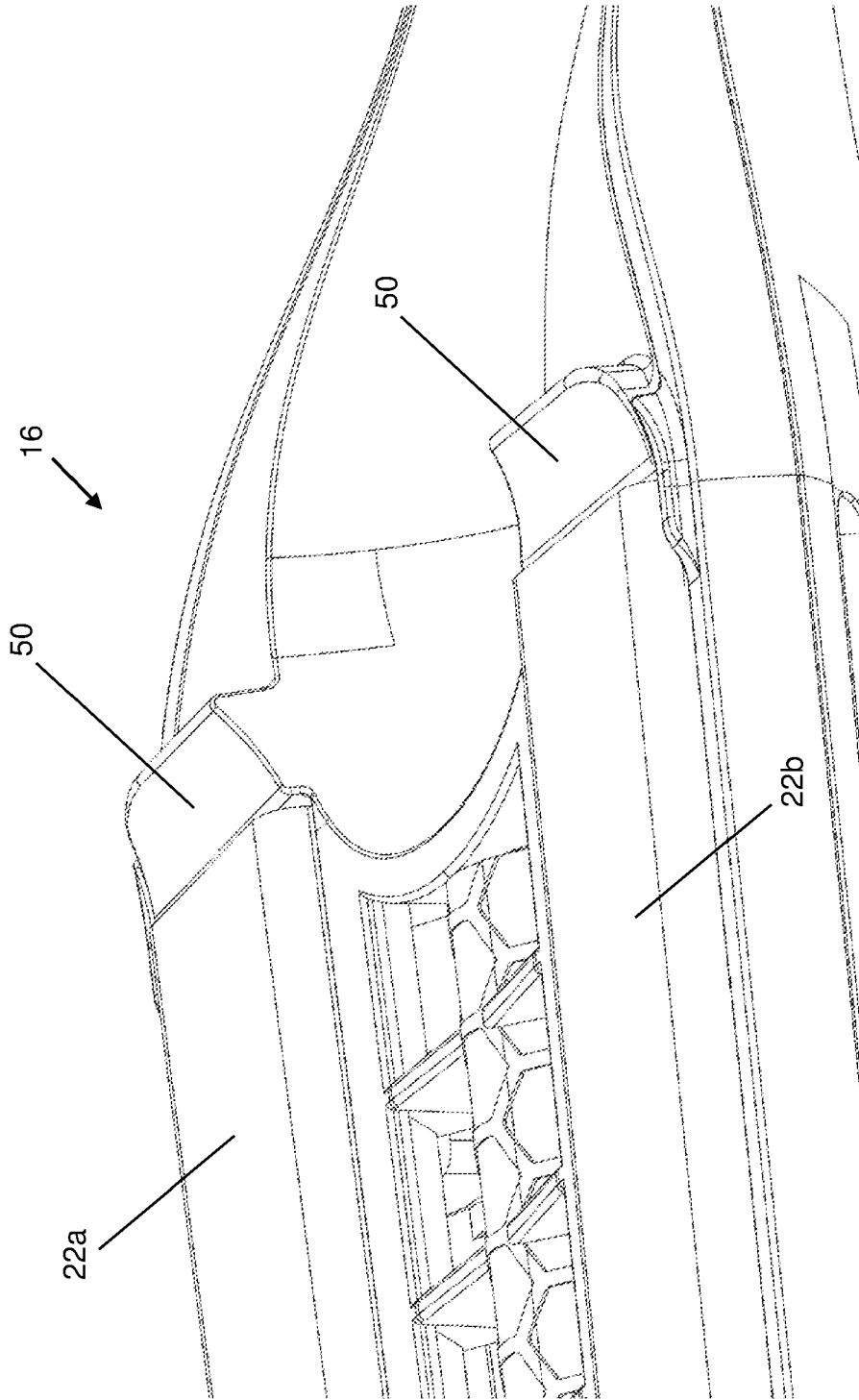

Figure 34

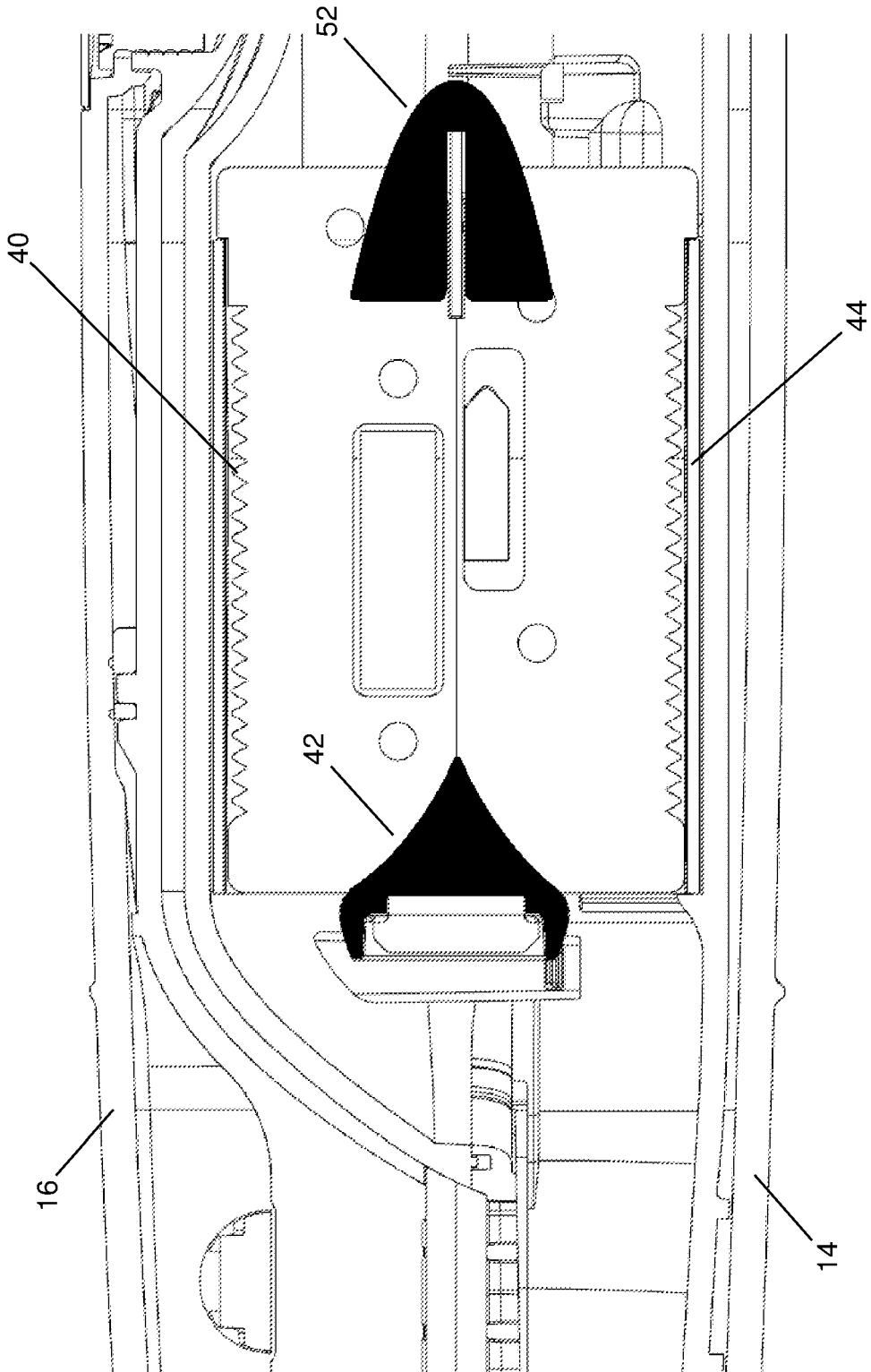

Figure 35

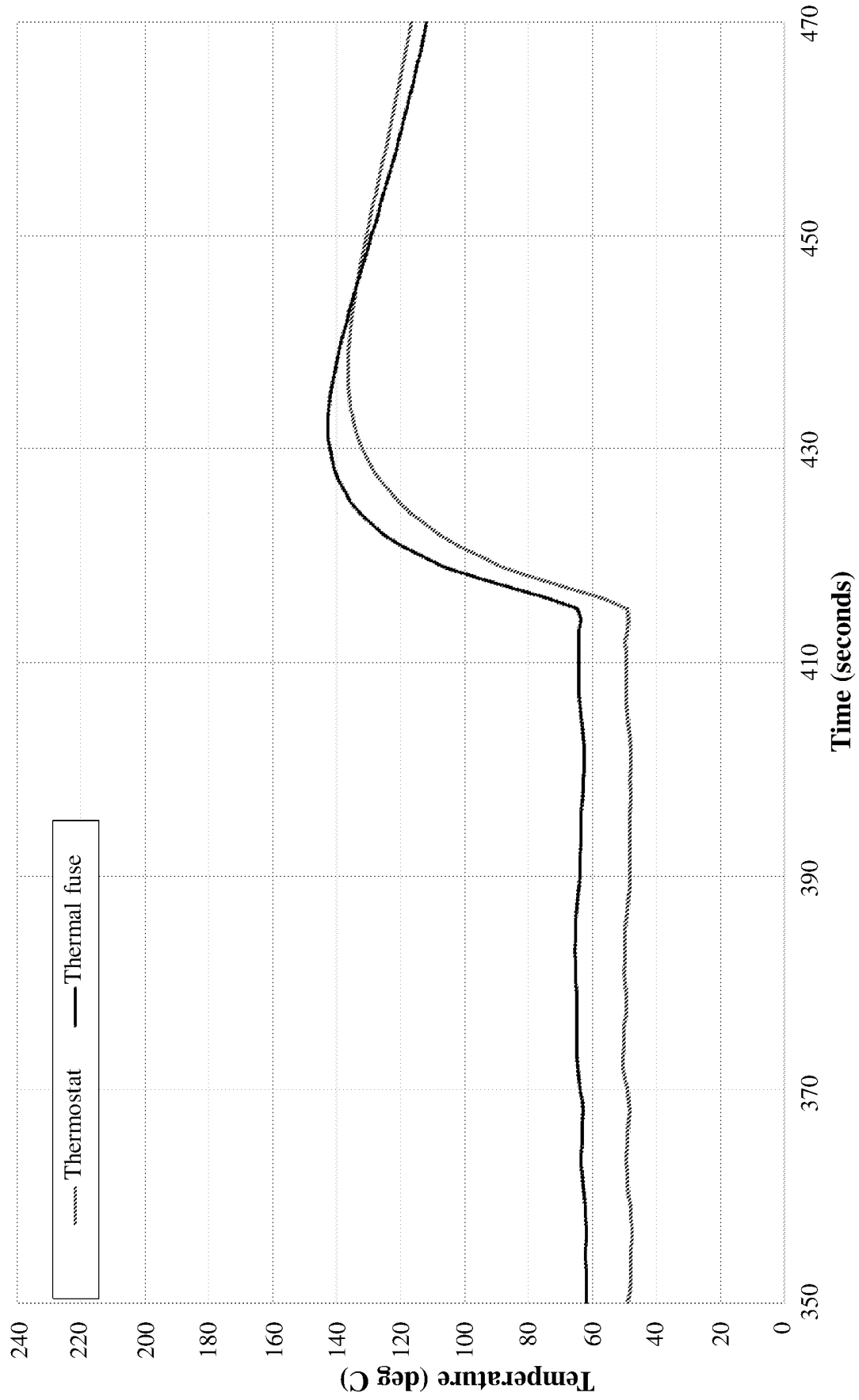

Figure 36

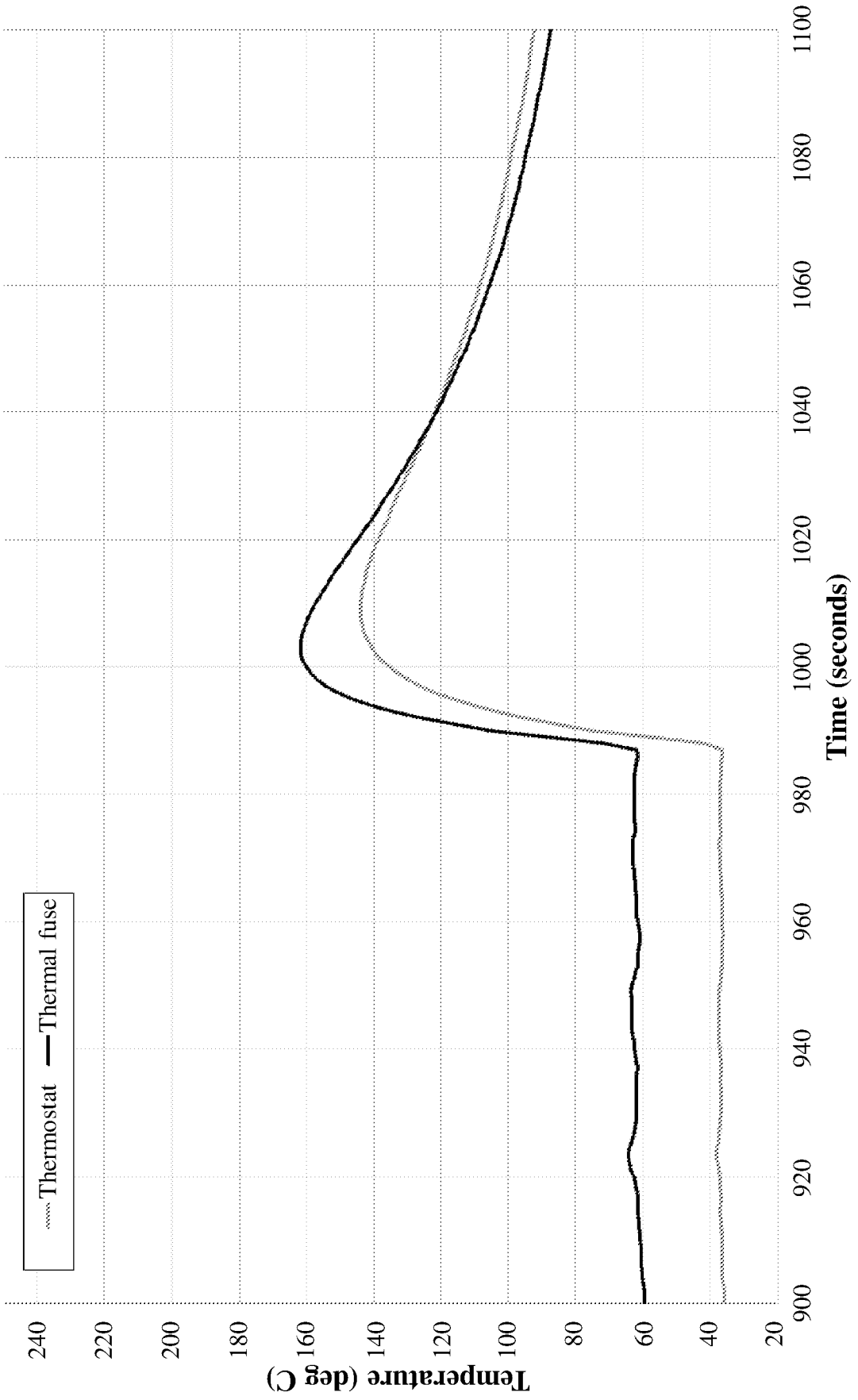

Figure 37

REFERENCES CITED IN THE DESCRIPTION

This list of references cited by the applicant is for the reader's convenience only. It does not form part of the European patent document. Even though great care has been taken in compiling the references, errors or omissions cannot be excluded and the EPO disclaims all liability in this regard.

Patent documents cited in the description

- US 2013247407 A1 [0007]