

[72] Inventor **Abraham Goodman**
101 Central Park W., New York, N.Y.
10023
 [21] Appl. No. **742,696**
 [22] Filed **July 5, 1968**
 [45] Patented **Jan. 11, 1972**

[54] **DECORATIVE APPLIQUES MOUNTED ON ARTICLES**
19 Claims, 14 Drawing Figs.
 [52] U.S. Cl. **161/7,**
 24/95, 24/204, 24/208, 40/140, 161/32, 161/114,
 161/18
 [51] Int. Cl. **A44c 13/00**
 [50] Field of Search **161/18,**
 109, 114, 7, 32; 24/95-96, 208.3, 204, 213;
 40/140, 143-144

[56] **References Cited**
UNITED STATES PATENTS
 1,869,314 7/1932 Patinot 40/140
 1,737,375 11/1929 King 40/143 UX

1,910,896	5/1933	Gormley.....	40/140
2,087,032	7/1937	Henrikson.....	40/140
2,141,989	12/1938	Weisser.....	40/140
2,682,724	7/1954	Pattillo.....	161/32 X
2,080,270	5/1937	Henry.....	161/32
2,668,340	2/1954	Jones.....	24/208.3 UX
2,178,055	10/1939	Stupell.....	24/208.3 UX
2,867,053	1/1959	Boor.....	161/18 X
2,502,860	4/1950	Leithiser, Jr.....	24/208.3 UX
3,049,781	8/1962	Cochran.....	24/213

FOREIGN PATENTS

544,878	4/1942	Great Britain.....	161/114
---------	--------	--------------------	---------

Primary Examiner—Philip Dier
Attorney—Paul S. Martin

ABSTRACT: An article such as a ring, a clasp, a barrette or a hair brush is decorated with one or more appliques by forming passages in the article such as converging or diverging pairs of passages or curved passages. Projections extend from the back of a decorative applique. Manual pressure is applied to the applique to drive the projections into the passages, deforming them and retaining the decorative applique on the article.

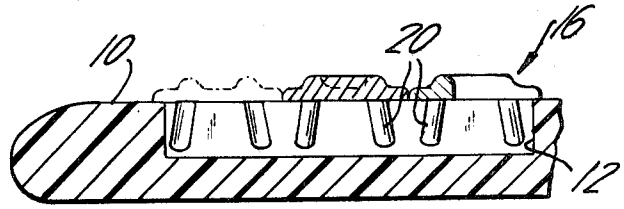

FIG. 1

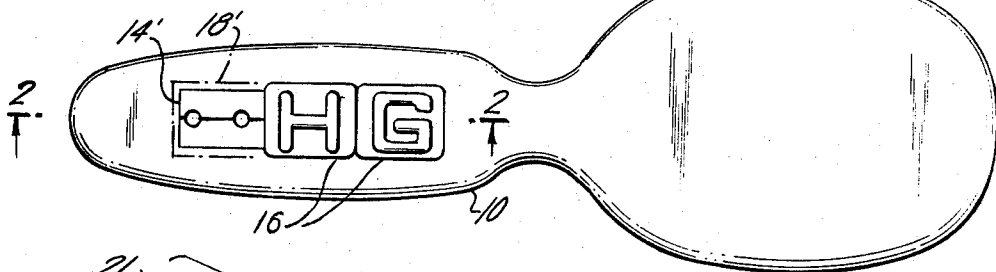

FIG. 3

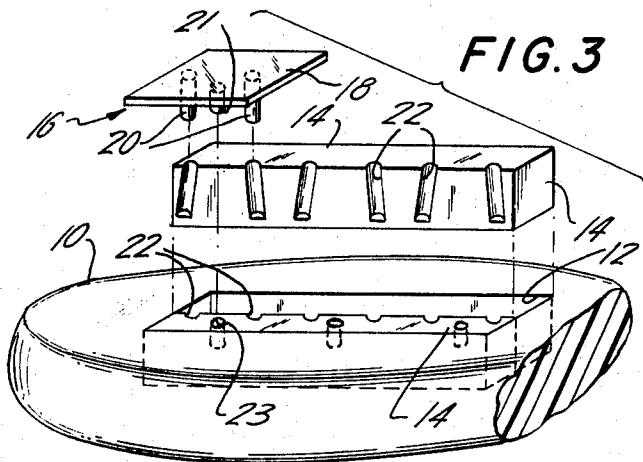

FIG. 2

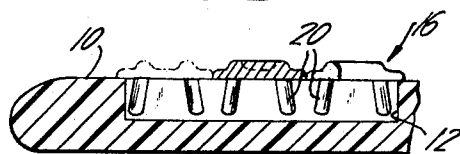

FIG. 4

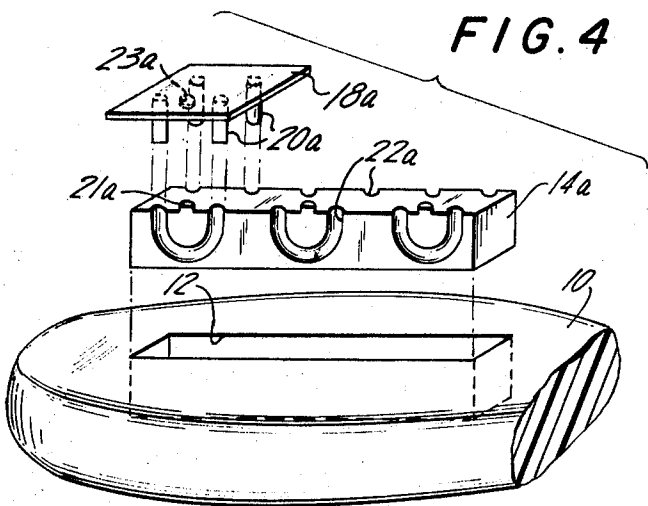

FIG. 5

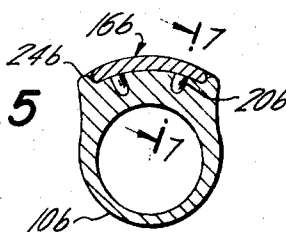

FIG. 6

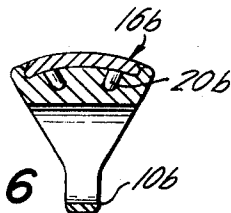
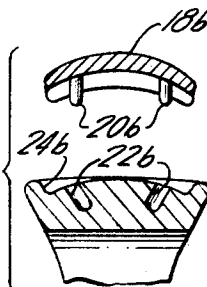

FIG. 7



INVENTOR.

ABRAHAM GOODMAN

BY

Karl Swartz

ATTORNEY

FIG. 8

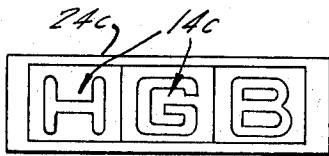

FIG. 10

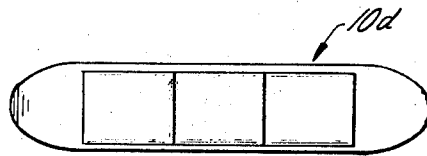

FIG. 9

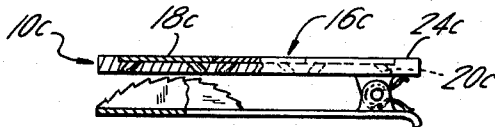

FIG. 11

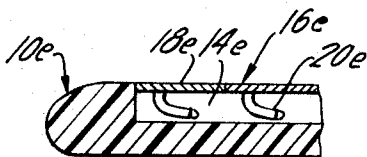
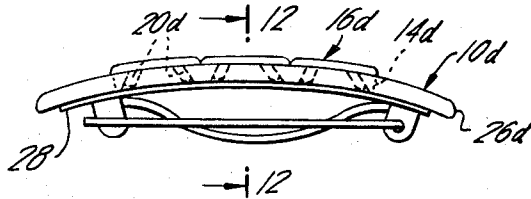

FIG. 13

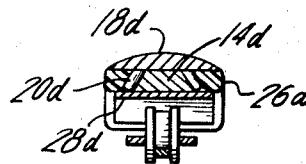

FIG. 12

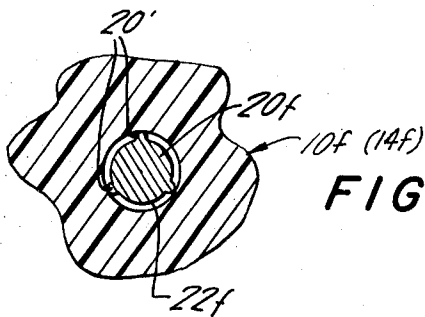

FIG. 14

INVENTOR.
ABRAHAM GOODMAN
BY *Paul S. Martin*
ATTORNEY

DECORATIVE APPLIQUES MOUNTED ON ARTICLES

The present invention relates to articles having decorative appliques and to methods of applying such appliques.

An object of this invention resides in providing a novel, widely applicable, simple and economical method of mounting decorative appliques on various articles, especially where the appliques are alphabetic characters that are to form a monogram or a name. A related object of the invention resides in providing a novel method of mounting such appliques wherein neither special tools nor special skills are needed.

A further object resides in providing novel articles bearing appliques secured quickly and in a novel highly effective manner, the construction enabling the appliques to be selected from an available stock, as in a retail store at the time of purchase.

A particular feature of the invention relates to alphabetic characters and novel mounting means therefor, enabling the characters to be mounted fast, accurately, and without resort to adhesives, or to the use of tools or any operation requiring operator skill.

Pursuant to one form of construction exemplifying the invention, articles to be decorated can be available for sale together with a wide selection of decorative appliques, especially alphabetic characters, of attractive design and finish. In this form of construction, each applique has plural readily deformable integral legs that can enter passages in the article. The passages are divergent or convergent or otherwise non-parallel. The legs become deformed as the applique is pressed toward and against the article. The legs have a reasonably tight fit in the passages. The tight fit may be enhanced by providing slender deformable ribs along the legs, making the legs initially oversize compared to the width or diameter of the passages. In a preferred form, they are of a material such as copper, brass, lead or white metal alloy that deforms readily as a result of the modest pressure needed in the mounting operation.

In a modification, the appliques are of a plastic such as nylon having integral legs of yieldable, initially nonparallel legs. The legs may be as divergent or as convergent as the leg-receiving passages, or more divergent or convergent than the leg-receiving passages. At the start of the mounting procedure, the tips of the legs are initially forced to assume the same spacing as the openings at the tops of the leg-receiving passages.

Whether of metal or of plastic, the appliques are merely pressed against the mounting areas of the article, using thumb pressure. The legs enter the leg-receiving passages and assume the shapes of the passages, whether convergent, divergent, skew, etc., and hold the appliques securely in place.

The passages that are to receive the legs of the applique can be curved, to special advantage. In that case, and particularly where the appliques are small or are located in position by a receiving frame or other locating means, it is feasible for each applique to have only one leg.

Ideally, no more than thumb pressure is required for mounting the appliques. Lack of tools or special cements will not interfere with the quick and economical mounting of the appliques by wholly unskilled persons. Neither the articles nor the appliques are exposed to risk of damage during the mounting operation. The mounted appliques are held in position securely.

The nature of the invention, including the foregoing and other objects, advantages and novel features, will be better appreciated from the following detailed description of several presently preferred embodiments illustrating the application of various aspects of the invention. These embodiments are shown in the accompanying drawings, wherein:

FIG. 1 is the rear view of a hair brush, hand mirror, or like article, embodying features of the invention;

FIG. 2 is a longitudinal cross-sectional view of part of the article in FIG. 1, as viewed from the line 2—2;

FIG. 3 is an exploded perspective of parts of the article of FIGS. 1 and 2;

FIG. 4 is an exploded perspective of parts of a modification of the article of FIGS. 1—3;

FIGS. 5 and 6 are cross sections of a finger ring along mutually perpendicular planes, as a further embodiment of certain features of the invention;

FIG. 7 is an enlarged fragmentary cross section of parts of the ring of FIGS. 5 and 6, viewed from the plane 7—7 in FIG. 5;

FIG. 8 is the front view of a tie clasp as a further embodiment of certain aspects of the invention;

FIG. 9 is a side view of the tie clasp of FIG. 8, parts being broken away and shown in cross section;

FIGS. 10 and 11 are front and side views of a barrette as a further embodiment of certain features of the invention;

FIG. 12 is a cross section of the barrette of FIGS. 10 and 11, as viewed from the plane 12—12 of FIG. 11;

FIG. 13 is a fragmentary cross section of a modification of the embodiments in FIGS. 1—3, FIG. 4 and FIG. 12, as viewed (for example) from section 2—2 in FIG. 1; and

FIG. 14 is an enlarged fragmentary cross section transverse to a leg in any of the illustrative embodiments of FIGS. 1—13.

In FIG. 1, the article shown has a handle 10 in which there is a cavity 12 containing a pair of inserts 14. The fit of the inserts in the cavity may be tight or an adhesive may be used, or any other expedient may be adopted for securing the inserts in the cavity or they may be incorporated in the article in a molding operation. Decorative units 16 are shown applied to the handle 10. These applied units or appliques include a body portion 18 whose underface is generally flat in this embodiment and fits against a flat area of handle 10 surrounding inserts 14. Legs 20 of each applique 16 diverge in the assembly (FIG. 2). The legs are received in passages defined by complementary grooves 22 formed in the confronting faces of inserts 14. The two-part insert might be molded (or cast) as one piece, except that this would complicate the manufacture of the insert.

A projection 21 extending downward from body portion 18 is located asymmetrically relative to legs 20, and projection 21 is off center relative to body 18 of the applique. A cavity 23 is formed in one part of two-part insert 14, located to receive projection 21 when the legs enter passages 22. This feature insures same-side-up insertion of all the appliques, and is especially useful where the appliques are alphabetic characters.

Three appliques are used to make up a monogram in the example shown in FIG. 1. Their lateral edges abut one another. All of the edges slope toward the lower face of the body portion. These features minimize the possibility of careless blows knocking the appliques off the article.

The appliques may be purely decorative, but monogram characters are of special importance. These characters may be flush with the body of the applique, or they may be grooved or in relief, contrasting with the adjoining area of the body. The finish of the appliques is important to their decorative purpose. Where the appliques are of metal, a bright plating of nickel, gold or the like is preferred, although colorful coatings and designs in contrasting colors or textures are also contemplated.

Appliques of a series having different designs or characters should be of the same size and shape, and the legs 20 should extend from corresponding locations of all the different appliques. A problem would exist in this respect if body 18 did not provide an area containing the decoration, as in the case of a series of different decorations each consisting of an openwork character. Where openwork characters are needed, it would be difficult to provide the same pattern of supporting areas for legs 20 in all the appliques of the series, e.g., where the letter "I" is involved. Imaginative design modification in each case can meet this problem, so appliques with openwork designs are broadly within present contemplation.

Legs 20 of each applique in FIGS. 1—3 diverge. That they are not parallel to each other is important, for if they were parallel, then some special technique, or a special adhesive, would be required that is effective and compatible with the particular materials of the appliques and the inserts. The non-parallel legs 20 form a purely mechanical but secure means of retention.

In assembling the decorated article, a first step involves placing inserts 14 in the cavity 12, and suitably securing them in place as by means of an adhesive, unless they are so made as to be tight or otherwise self-locking in the recess. Alternatively, the insert may be molded into the handle 10. The bottoms of passages 22 are closed, and will not fill with plastic in case the article is molded with the insert in place. Since the mounting of the insert in the handle is ordinarily carried out by the manufacturer, any convenient technique may be used for fixing the insert in the article.

Legs 20 of the appliques of FIG. 3 are parallel at the start of the mounting operation. The free ends of the legs are inserted into the open ends of the passages formed by grooves 22, and moderate frontal pressure on the applique forces legs 20 to follow the passages. The legs are preferably of a material that becomes permanently deformed, so that as soon as the body 18 of the applique reaches the surface of article 10, nothing further is needed to complete the assembly. In case of an applique being applied upside down, projection 21 would reach a flat area of insert 14, thus being rejected. With right-side-up mounting of an applique, projection 21 would enter cavity 23, permitting full mounting of the applique. Choice of the group of appliques to be mounted is left to the individual. The extreme simplicity of the operation makes it eminently practical for the choice of appliques to be deferred to the time of purchase in a retail store.

The body and legs of each applique 16 are of one integral, unitary piece, and in a preferred and specially advantageous embodiment they are made by molding or casting a readily deformable metal such as lead, a suitable white-metal alloy or the like. The molded unit is given an attractive surface finish. The legs of the applique take a set when pushed into oppositely slanted passages, and thus are effective to secure the appliques to the article. The legs fit tightly in the passages, but a force-fit is avoided. As a practical detail, the legs do not completely fill the passages in the sense that cast metal fills a die, for if such complete filling were wanted, then an inordinately large force would be required during insertion and this would deform or destroy the applique.

The whole article is readily made by low-cost large-volume manufacturing operations. A broad range of materials are suitable. Relatively soft and highly ductile metal is the preferred material for the appliques, but various plastics may be substituted, such as a suitable grade of nylon. Where the material is plastic the legs 20, advantageously, are initially divergent. Inserts 14 may be made of cast metal or of a molded plastic. In any case, both the inserts and the appliques should be molded for large-volume low-cost production. The term "molded" is used herein as meaning formed in a mold without requiring either heat or pressure, or using heat or pressure, or both. Legs 20 are integral with body 18 of the appliques. The term integral is used here to denote the continuity of the same material and freedom from joints between the legs and the body. Such integral appliques are readily made by molding. The article 10 itself is also molded for uniformity and economy, but the manufacturing methods to be used for making the article may be decided by other considerations.

FIG. 4 illustrates a modification of the embodiment of FIGS. 1-3. In place of two companion inserts 14 to form passages for the legs of the applique, the passages are formed in the embodiment of FIG. 4 by the grooves 22a in insert 14a, bounded by the walls of cavity 12 in article 10. Four legs 20a extending integrally from body 18a can readily be accommodated. FIG. 4 shows further that the passages may be curved. Where it is feasible to make curved passages, this is of some advantage. Thus, one may consider what happens when legs 20 of a white-metal applique are first being inserted into passages formed by the grooves 22 of FIG. 3. The tip of each leg first bends outward in relation to the adjoining initially straight part of the leg. As the leg is pushed deeper, the just-bent region is straightened in the straight passage 22 while a bend forms in another part of the leg. The progressive straightening of each just-bent portion of the leg requires

some effort. The material chosen should retain its strength after this treatment. However, the curved shape of the passages in the embodiment of FIG. 4 avoids any weakening that might result from the progressive bending following by straightening of the bends in the legs as they are driven into the passages. Moreover, the curved legs provided firm retention. In FIG. 4, body 18a of the applique has a recess 23a and insert 14a has a corresponding projection 21a for insuring right-side-up mounting of all the appliques.

The body 18 of the applique in FIGS. 1-4 is flat, although it need not be flat as will be seen below. It extends outside the crevice 14' as indicated by outline 18' in FIG. 1 and conceals the crevice. Accordingly, legs 20 are located at parts of body 18 that are spaced inward of the margin. A similar effect is achieved where the crevice is aligned with the outline 18', thus obscuring the crevice.

Four legs are shown, including a pair of legs at the rear side of insert 14a as viewed in the drawing, and a pair at the front side of the insert. Because of the curvature of the legs, the use of nonparallel legs becomes less important. Therefore two legs preferably curving in opposite directions (as at the diagonals of the applique) can be very secure where the applique is too small for four legs.

FIGS. 5-7 show features of the invention applied to a finger ring 10b. Body 18b of the applique 16b is curved in two directions, approximating part of a sphere. Four parallel legs 20b extend from body 18b before insertion into passages 22b. After insertion the legs are no longer parallel, but slope along diagonals toward each other, in the manner of the corners of a pyramid. Inserts 14 and 14a of FIGS. 3 and 4 are omitted here. Passages 22b are formed in the ring itself. A raised frame 24b surrounds the applique and protects the applique against being defaced and against its being loosened by accidental blows.

The tie clasp 10c of FIGS. 8 and 9 has a protective and decorative frame 24c surrounding the flat body portions 18c of the appliques. These are commonly letters that form a monogram. Legs 20c diverge into corresponding passages suitably formed in the tie clasp. FIGS. 10-12 illustrate a barrette 10d of metal operating parts on a plastic body in which divergent passages are formed for legs 20d. These passages are advantageously formed in the side surfaces of an insert 14d similar to the inserts 14 and 14a of FIGS. 3 and 4. The insert 14d in FIGS. 10-12 can be inserted readily in the rear of plastic body 26d and covered by a metal or plastic strip 28d forming part of the barrette mechanism. Strip 28d is then fastened in customary fashion to the body 26d. This form of construction has the advantage that both the insert 14d and the cavity in body 26d to receive the insert can have lateral faces that are not parallel (see FIGS. 3 and 4 for comparison) but diverge from the top surface toward the bottom. No tight fit or adhesive is needed to hold the parts in assembly. Further, the passages to receive legs 20d and the legs in those passages are not only slanted and optionally curved, in the form of grooves 22a, FIG. 4, but in addition the legs and the grooves at opposite sides of the insert diverge in relation to each other, as shown in FIG. 12. This enhances the retention of the applique and makes possible the use of shorter legs in a thinner body 10d than would be effective with parallel lateral faces of the cavity and the insert. In the same manner, four diagonally diverging or converging passages for four-legged appliques can be used even when no insert 14 is used.

The body portions of the appliques in FIG. 12 slope to thin edges and merge with the edge contour of the barrette, for avoiding sidewise impacts tending to loosen the applique.

FIG. 13 shows a handle 10e with a two-part insert 14e divided in the manner of insert 14 in FIGS. 1-3, having curved passages (as in FIG. 4) for receiving legs 20e of appliques 16e. Each applique has only one leg 20e that extends integrally from an offcenter part of body 18e, assuring consistent right-side-up mounting that is of importance in the case of alphabetic characters. The cavity in handle 10e that receives insert 14e is made deep enough to form a frame about bodies

18e. This feature coupled with edge-to-edge abutment of the straight sides of successive bodies 18 inhibits the natural tendency of the appliques to be twisted out of their installed positions. This frame feature is not essential since mating cavity-and-locating projections can be added if needed, as shown at 21, 23 in FIG. 3 and 21a, 23a in FIG. 4.

FIG. 14 shows how a leg 20f (representing legs of metal or plastic appliques in all the FIGS.) can have a number of deformable lengthwise ribs 20' (three are shown) that make the transverse dimensions of the legs oversize compared with the diameter of passage 22f in the body or insert that is to receive the leg. This means that the legs, when pressed into the passages using only moderate pressure, can occupy the transverse dimensions of the passage without looseness. The legs do not fill up the passages, since in practice that would necessitate a great amount of force in inserting the legs. Moreover, it would almost inevitable damage the finish of the insert, possibly destroying the whole applique.

In each of the embodiments above, the described appliques may be mounted on relatively frail or fragile or deformable materials or slender supports. The described construction avoids possible damage to either the support or the applique that could occur if riveting or the like were needed in mounting the appliques. The leg-receiving passages are accessible at their outer ends where the legs are admitted, but the passages can be closed or blind at the opposite end since no access is needed to the tips of the legs during the mounting operation. This means that there is an unmarred surface at the side of the article opposite the applique, and it means that short-legged appliques can be mounted on relatively thick articles. Decorating colors and set gems may be used on the bodies of the appliques. The construction and mounting method described are effective for a wide range of sizes, but are especially advantageous in the case of applique bodies of about three-sixteenths inch square.

Various presently preferred embodiments of the invention in its various aspects are described specifically above, but manifestly modifications in matter of detail and varied applications of the novel features will occur to those skilled in the art; and it is therefore appropriate that the invention should be construed broadly in accordance with its full spirit and scope.

What is claimed is:

1. A decorated article including a base having plural elongated nonparallel passages extending therein from openings in a face thereof, and a decorative preformed applique directly abutting against the face of the base, said applique having a body and preformed readily bendable legs projecting from points on the rear of the body corresponding to said openings, and into and nearly conforming transversely to said nonparallel passages.

2. A decorated article in accordance with claim 1, wherein said applique has legs of a highly ductile metal.

3. A decorated article in accordance with claim 1, wherein said base has a frame containing said applique and in abutment with at least part of the outline of the applique.

4. A decorated article in accordance with claim 1 having plural appliques each of the form as aforesaid and having generally rectangular outlines, said appliques being disposed in a row and the successive appliques in the row having abutting lateral edges, thereby enhancing the stable positioning of said appliques.

5. A decorated article in accordance with claim 4, wherein the body of said applique has three-dimensional decorative portions.

6. A decorated article in accordance with claim 1, wherein said base has a cavity and an insert in said cavity, said insert having plural passage-forming grooves in each of two opposite lateral surfaces thereof, said grooves cooperating with respective walls of the cavity to form two rows of said passages.

7. A decorated article in accordance with claim 6, wherein

said insert comprises two parts having confronting lateral surfaces having complementary grooves therein forming said passages.

8. A decorated article in accordance with claim 1, wherein the rear surface of the body of the applique is flush against the face of the base and wherein the front surface of the body of the applique slopes at the edges thereof substantially to said rear surface, for avoiding sidewise impacts that might loosen the applique.

9. A decorated article in accordance with claim 1, wherein the body and legs of said applique are integral and of highly ductile metal.

10. A decorated article in accordance with claim 1, having plural appliques each of the aforesaid form the legs of which extend from the bodies thereof in duplicate patterns into corresponding duplicate patterns of said openings in said base.

11. A decorated article in accordance with claim 10, wherein said article includes means having grooves in at least one lateral surface thereof for providing said passages and said openings.

12. A decorated article in accordance with claim 1, wherein said legs have longitudinal ribs thereon tightly bearing against the surfaces of the leg-receiving passages.

13. A decorated article in accordance with claim 1, having plural appliques, wherein said body of each of said appliques has an asymmetrically located orienting formation at its under side and said base has a correspondingly located complementary orienting formation for each said applique for assuring mounting of said appliques in predetermined relation to each other.

14. A decorated article, including a base, having at least one curved passage extending therein, and at least one decorative applique including a body directly abutting against said base, said applique having at least one curved leg of readily bendable material tightly contained in a corresponding curved passage of said base.

15. A decorative article in accordance with claim 14, wherein said base has an insert providing a side face having a curved groove therein forming said curved passage.

16. A decorated article in accordance with claim 1, having plural appliques, said base including a main member having a cavity defined by lateral walls opening into said face and at least one insert largely occupying said cavity and flush with said face, at least said one insert and said cavity wall having confronting surfaces extending to said face, at least one of said confronting surfaces being grooved so as to form a said passage, said appliques having legs spaced inward of the edges of the bodies thereof so that the bodies cover the outline of the insert at said face.

17. A decorated article in accordance with claim 1, wherein said base includes a main member having a cavity defined by lateral walls that diverge away from said face, an insert snugly received in said cavity and having lateral walls correspondingly diverging away from said face, and retaining means at the rear of the insert fixed to said base and holding the insert in said cavity, said passages being defined by grooves in at least certain ones of said lateral walls.

18. A decorative article in accordance with claim 1, wherein said base has a frame conforming to at least part of the outline of the applique, and in which the base of the article has a cavity formed therein within said frame, said base including an insert received in said cavity and having lateral surfaces essentially conforming to lateral surfaces of the cavity, at least one of said surfaces being grooved to form at least one of said passages.

19. A decorated article in accordance with claim 1, wherein each said applique has a plastic body and yieldable plastic legs integral therewith that are at least as nonparallel to each other initially as said passages.

* * * * *