

April 28, 1953

E. D. MEADOWS ET AL

2,636,221

TOP ROLL

Filed Aug. 6, 1947

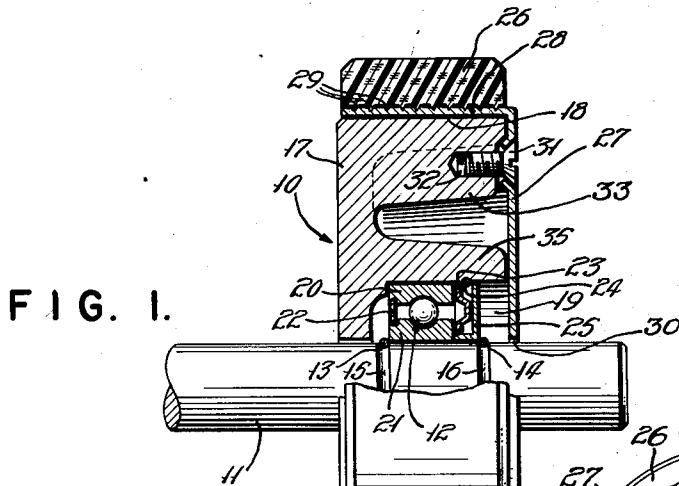

FIG. 1.

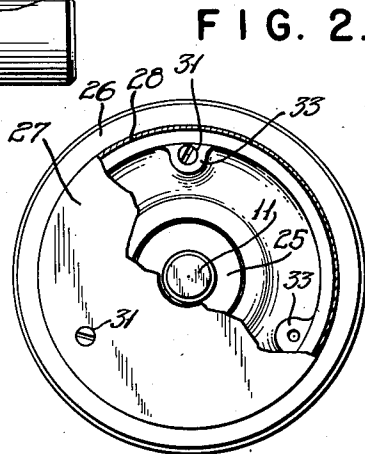

FIG. 2.

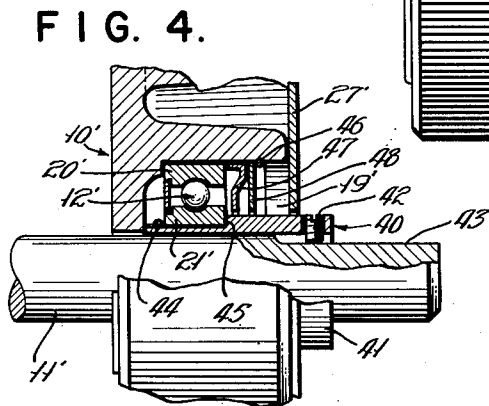

FIG. 4.

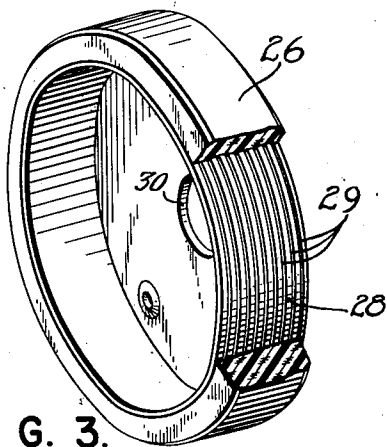

FIG. 3.

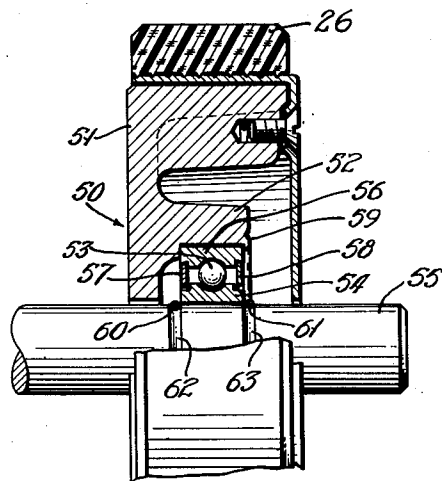

FIG. 5.

INVENTORS.  
ERNEST D. MEADOWS  
RICHARD K. WHITEHEAD

*Mitchell Beckett*  
ATTORNEYS.

BY

# UNITED STATES PATENT OFFICE

2,636,221

## TOP ROLL

Ernest D. Meadows and Richard K. Whitehead,  
Atlanta, Ga., assignors to Meadows Manu-  
facturing Company, Atlanta, Ga., a corporation  
of Georgia

Application August 6, 1947, Serial No. 766,614

10 Claims. (Cl. 19—142)

1

Our invention relates to rolls for particular application to the drafting of fibers, as in worsted spinning frames.

In the past, it has been the practice to apply cot material directly to drafting rolls, such as top rolls, in machines of the character indicated. When the cots have become worn and have needed replacement, the entire roll has had to be removed and then immersed in a caustic solution for soaking in order to loosen the cot. Not only may this soaking process be harmful to the bearings for the roll, but the roll-servicing operation is time consuming and means that a relatively large stock of serviced rolls must be on hand in order to minimize down time for the machine.

It is, accordingly, an object of our invention to provide an improved roll wherein the above difficulties may be minimized.

It is another object to provide an improved top roll in which a cot may be removed without disturbing the adjustment of the roll in its mounting upon a shaft.

It is a further object to provide an improved cot-supporting structure.

Still another object is to provide an improved means for mounting a top roll on a shaft.

Other objects and various further features of the invention will be pointed out or will occur to those skilled in the art from a reading of the following specification in conjunction with the accompanying drawings. In said drawings:

Fig. 1 is a partially sectionalized front view of a top roll incorporating features of the invention, the roll being shown mounted on a roll shaft;

Fig. 2 is a partly broken away side view of the roll of Fig. 1;

Fig. 3 is a perspective view of a part of the assembly of Figs. 1 and 2;

Fig. 4 is a fragmentary partly sectionalized view of a top roll illustrating a modified mounting arrangement; and

Fig. 5 is a fragmentary sectionalized view of a further modification according to the invention.

Briefly stated, our invention contemplates an improved roll construction wherein a cot is carried by a member which may be removably secured to the body of the roll, without disturbing the roll in its mounted position on the roll shaft. In the specific form to be described, the body of the roll is a machined casting having a generally cylindrical outer surface and a central bore, to receive antifriction bearing means. The

2

cot is supported on a cup which fits the generally cylindrical outer surface of the roll and which extends radially in, substantially to close off the open end of the bore. The cup, and with it of course the cot, may be readily removed by merely loosening screws between the bottom of the cup and the roll casting.

Referring to Figs. 1, 2, and 3 of the drawings, our invention is shown in application to a top roll 10 revolvably mounted on a roll shaft 11, as for use in the drafting of fibers on a worsted spinning frame. The roll 10 may be supported on the shaft 11 by antifriction bearing means 12 and secured in position thereon as by snap rings 13—14 seated in grooves 15—16 in the shaft 11. In the form shown, the roll 10 includes a body 17 which is preferably a casting and which for lightness may be an aluminum-alloy permanent-mold casting. The body 17 may be formed with a generally cylindrical outer surface 18 and with a central bore 19, for bearing purposes.

In the form shown, the antifriction bearing 12 is a ball bearing having an outer ring 20 seated in the bore 19 and an inner ring 21 seated on the shaft 11, against the snap ring or shoulder 13. On one side, the bearing means 12 may include a single sealing ring 22 carried by the outer bearing ring 20 and extending radially into preferably close clearance relation with the inner ring 21. On the other side of the bearing there may be a labyrinthian seal which may comprise a first seal member 23 fitting the bore 19 and held against the outer ring 20, as by a snap ring 24 in the bore 19. The seal may be enhanced by provision of a second seal member 25 of L-shaped section having a cylindrical portion carried by the shaft 11 and a radially outwardly extending flange extending into clearance relation with the bore 19 and with the snap ring 24. The seal member 25 may be held in abutment with the inner ring 21, as by employment of the snap ring 14. It will be clear that the ring 23 rotates with the roll 10 and that, therefore, the ring 23 preferably clears both the inner bearing ring 21 and the seal member 25.

In accordance with the invention, a cot 26 is carried by a member 27 removably secured to the main body 17 of the roll 10. The member 27 in the form shown is a cup having a generally cylindrical wall 28 upon which the cot 26 is secured. The cot 26 may be of conventional rubber-and-cork or the like combination; it may be secured by employment of a suitable adhesive to the cylindrical wall 28. In a preferred form, the tightness of fit is improved by a roughening

of the outer surface of the wall 28, as by the turning of a relatively shallow spiral groove 29 in the outer surface thereof.

The wall 28 preferably closely forms a sliding fit with the outer cylindrical surface 18 on the body 17 of the roll. The bottom or radially extending part of the cup 27 is provided with a central aperture 30 to permit passage of the shaft 11 therethrough, and the clearance between the opening 30 and the shaft 11 is preferably close for purposes of enhancing the seal of the anti-friction bearing means 12. The cup member 27, and with it the cot 26, is shown removably secured to the body 17 by means of screws 31, which are preferably countersunk to provide a completely flush outer roll surface; the screws 31 may be driven into holes 32 tapped in enlarged portions or ears 33 formed in the body 17. In the form shown, the roll 10 is of relatively large diameter and the casting 17 is preferably, therefore, substantially hollowed out. Thus, the outer generally cylindrical surface 18 may be radially spaced from a hub portion 35 having the bore 19. In the sense of the drawings, the left-hand side of the body 10 forms a closed side of the roll to join the hub 35 with the outer cylindrical portion, so that when the cup 27 is fitted, the entire roll assembly may be smooth in external appearance.

In Fig. 4 I show an alternative means for mounting a roll, such as the roll of Figs. 1, 2, and 3, wherein it may be desired adjustably to position a fully assembled roll 10' along the mounting shaft 11. As before, the roll 10' may be supported by anti-friction bearing means 12' fitted within a bore 19'. The inner ring 21' of the bearing, however, is preferably seated on a sleeve 40 which includes an axially projecting portion 41 extending beyond the cot-supporting cup 27'. The projecting portion 41 of the sleeve 40 may carry suitable securing means, such as a set screw 42, for engagement as with a flat 43 formed on the end of the shaft 11'. The inner ring 21' may be positioned on the sleeve 40 by means of a snap ring 44 holding the ring 21' against a radial shoulder 45. In the form shown, the outer bearing ring 20' is held in the bore 19' by means of a snap ring 46 pressing a pair of labyrinthian seal members 47-48 against the outer ring 20'. Both seal members 47-48 and the cup member 27' preferably extend into clearance relation with the sleeve 40.

In Fig. 5 is shown a further modification of the invention wherein a top roll 50 includes a roll member 51 having a hub 52 supported in a simplified manner by an anti-friction bearing 53. The bearing means 53 may again comprise an inner ring 54 seated upon the shaft 55 and an outer ring 56 seated in a bore within the hub 52. Seal means 57-58 for both sides of the bearing means 53 may be formed with and carried by the bearing itself. The outer bearing ring 56 may be held in position within the bore in hub 52 by staking, prick-punching, swaging, or otherwise radially inwardly deforming a part 59 of the lip of hub 52, as shown. The inner bearing ring 54 may be adjustably positioned along the shaft 55 in the manner described in connection with Fig. 4, or it may be fixedly located, as by snap rings 60-61, in grooves 62-63 in the shaft 55.

It will be appreciated that we have described a relatively simple roll construction for particular application to top rolls in which the servicing and maintenance of cots is a major problem.

In all the described forms the cot may be very easily removed without disturbing the roll or its position on a shaft, and immersing of the worn cot and its supported member in caustic solution can in no way harm the rest of the roll including the bearing. The cot-supporting structure is of such simplicity and may be made at such low cost as to make it feasible to stock up assembled cot-supporting structures for immediate replacement when necessary.

While we have described our invention in detail for the preferred forms shown, it will be understood that modifications may be made within the scope of the invention as defined in the appended claims.

We claim:

1. In a top roll for spinning frames and the like, a wheel assembly including anti-friction bearing means for supporting said assembly on a shaft, said wheel assembly including a part extending radially inwardly on one side of said anti-friction bearing means and to an extent for relatively close clearance relation with the shaft, and a cot assembly to be secured to said wheel assembly, said cot assembly including a cupped member having a generally cylindrical outer surface, a cot carried by said surface, and securing means between the cupped part of said member and said wheel assembly, said cupped member including a part extending radially inwardly on the other side of said anti-friction bearing means and to an extent for relatively close clearance relation with the shaft.

2. In a device of the character indicated, for spinning frames and the like, a roll including a body having a cylindrical outer surface and including a hub, said body having a closed side and an open side with the hub supported by the closed side, said hub having a bore facing said open side, anti-friction bearing means in said bore for supporting said roll on a shaft, and a cup having a cylindrical cot-supporting portion to fit said cylindrical surface and a bottom extending over the open side of said bore.

3. In a top roll for spinning frames and the like, a roll body including a cylindrical outer surface and having a central bore substantially closed on one side and open on the other side, anti-friction bearing means including an outer and an inner ring, said outer ring being seated in said bore, and a cot-supporting cup including an annular portion fitting said cylindrical surface and a bottom portion extending radially inwardly substantially to the inner diameter of said inner bearing ring in order substantially to close the open side of said bore.

4. In a device of the character indicated for spinning frames or the like, a roll having a bearing-receiving bore substantially closed on one side and open on the other side, said roll having a cylindrical periphery, and a cot-supporting cup including a cylindrical bore fitting over the outer cylindrical periphery of said roll and having a radially inwardly directed disc flange to partially close the open side of said bearing-receiving bore.

5. A device according to claim 4, and including anti-friction bearing means in said bearing receiving bore, a mounting sleeve for support upon a shaft, said sleeve including shoulder means for said anti-friction bearing means, said sleeve including an axially projecting portion projecting axially beyond said cup, and securing means carried by said projecting portion for locking said projecting portion to a shaft.

6. In a device of the character indicated for

5

spinning frames and the like, a roll including a cylindrical outer surface and having a central bore, antifriction bearing means in said bore, said antifriction bearing means including an outer ring fitting said bore, said roll including a radially inwardly deformed portion extending radially inward of a part of said outer ring for retaining said ring in said bore, and a cot-supporting cup fitting over said cylindrical surface and removably secured to said roll.

7. In a roll for spinning frames and the like, a roll body member to be revolubly supported on a shaft and including a substantially flat end extending radially inwardly for relatively close running clearance relation with the shaft, said body member including a cylindrical peripheral surface and having a bore open to the other end to insertably receive bearing means, a cup-shaped member of sheet material including a cylindrical cot-supporting part closely fitting over the cylindrical peripheral surface of said body member, said cup-shaped member further including a substantially flat bottom substantially closing the open end of said bore and with a central opening for relatively close running clearance relation with the shaft, and means axially securing the bottom of said cup-shaped member to said body member, whereby no matter how tight said securing means may be set there need be no stressing of the cot-supporting part of said cup-shaped member.

8. In a top roll for spinning frames and the like, a roll body including a generally radial disc end and a cylindrical rim at the periphery of said disc end and extending toward the other end of said body, a central hub for a bearing carried by said disc end, a cot-supporting member comprising a cylindrical sleeve fitting over the outer surface of said cylindrical rim and overlapping said other end of said body, said sleeve at the end op-

6

posite said disc end having a generally radial inward disc flange extending over said other end of said body and having a central shaft passage, and means for securing said disc flange to said rim for holding said roll body and said cot-supporting member together.

9. In the combination defined in claim 8, said cot-supporting sleeve having a roughened outer surface to assist in holding a cot thereon.

10. In a device of the character indicated for spinning frames and the like, a roll having a bore for receiving an antifriction bearing including inner and outer rings with the outer ring fitting in said bore, a sleeve having a bore to receive a shaft and having an outer cylindrical surface received in the bore of the inner bearing ring of said antifriction bearing, means for securing the inner ring to said sleeve, and means carried by said sleeve and accessible externally of said roll for securing said sleeve to a shaft for locating and holding the entire device on a shaft.

ERNEST D. MEADOWS.  
RICHARD K. WHITEHEAD.

References Cited in the file of this patent

UNITED STATES PATENTS

Number	Name	Date
395,938	Wright	Jan. 8, 1889
981,307	Ragsdale	Jan. 10, 1911
2,072,451	Hughes	Mar. 2, 1937
2,267,443	Cobb	Dec. 23, 1941
2,415,578	Courtney	Feb. 11, 1947
2,417,239	Courtney	Mar. 11, 1947

FOREIGN PATENTS

Number	Country	Date
15,335	Great Britain	of 1904
144,940	Great Britain	June 24, 1920
237,482	Great Britain	July 30, 1925
592,743	France	Aug. 8, 1925