



US008627698B2

(12) **United States Patent**
Campo et al.

(10) **Patent No.:** **US 8,627,698 B2**
(45) **Date of Patent:** **Jan. 14, 2014**

(54) **DEFORMATION OF THIN WALLED BODIES**

(75) Inventors: **Santiago Garcia Campo**, Llodio (ES);
Juan Saiz Goiria, Llodia (ES)

(73) Assignee: **Envases (UK) Limited**, Port Talbot (GB)

(*) Notice: Subject to any disclaimer, the term of this patent is extended or adjusted under 35 U.S.C. 154(b) by 0 days.

(21) Appl. No.: **13/569,530**

(22) Filed: **Aug. 8, 2012**

(65) **Prior Publication Data**

US 2012/0297847 A1 Nov. 29, 2012

Related U.S. Application Data

(63) Continuation of application No. 12/900,864, filed on Oct. 8, 2010, now Pat. No. 8,245,556, which is a continuation of application No. 12/564,807, filed on Sep. 22, 2009, now abandoned, which is a continuation of application No. 12/114,416, filed on May 2, 2008, now abandoned, which is a continuation of application No. 11/314,630, filed on Dec. 21, 2005, now Pat. No. 7,398,665, which is a continuation of application No. 10/182,643, filed on Sep. 30, 2002, now Pat. No. 7,003,999.

(30) **Foreign Application Priority Data**

Feb. 10, 2000 (GB) 0003033.8
Oct. 27, 2000 (GB) 0026325.1
Feb. 9, 2001 (WO) PCT/GB01/00526

(51) **Int. Cl.**
B21D 51/26 (2006.01)

(52) **U.S. Cl.**
USPC 72/94; 72/379.4; 72/715

(58) **Field of Classification Search**

USPC 72/94, 105, 379.4, 405.05, 361, 414,
72/715, 407; 413/69; 101/3.1, 5, 22, 23,
101/28, 29
See application file for complete search history.

(56) **References Cited**

U.S. PATENT DOCUMENTS

1,608,119	A	11/1926	Perchard	
2,161,963	A	6/1939	Khatunzeff	
2,351,519	A *	6/1944	Jonsson	101/5
2,734,451	A *	2/1956	Vitense	101/5
2,843,253	A	7/1958	Peterson et al.	
2,966,872	A	1/1961	Schmocker	
3,247,548	A	4/1966	Fields et al.	
3,490,404	A	1/1970	Vanderlaan et al.	
3,628,451	A	12/1971	McClellan et al.	
3,630,334	A	12/1971	Connoly et al.	
3,687,098	A	8/1972	Maytag	

(Continued)

FOREIGN PATENT DOCUMENTS

EP	0275369	7/1988
EP	0507380	10/1992

(Continued)

Primary Examiner — Edward Tolan

(74) *Attorney, Agent, or Firm* — Gordon & Jacobson, PC

(57) **ABSTRACT**

A thin walled body is deformed in a process in which the body is gripped securely in a holding station and, while gripped in the holding station, tooling engages to deform the peripheral wall of the body at a predetermined wall zone. The tooling is provided at a tooling station which is adjacent the holding station during deformation. The predetermined wall zone is co-aligned with the tooling by rotation of the body about an axis prior to securing at the holding station.

12 Claims, 11 Drawing Sheets

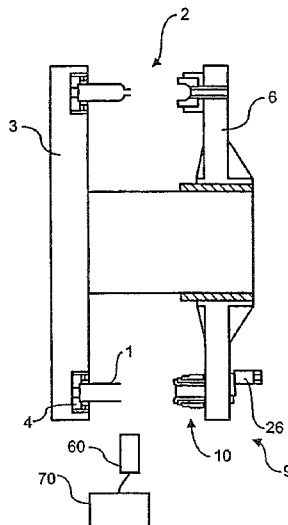

(56)

References Cited

U.S. PATENT DOCUMENTS

3,688,537 A 9/1972 Schneider
 3,690,487 A 9/1972 Evans, Jr. et al.
 3,698,337 A 10/1972 Brawner et al.
 3,967,488 A 7/1976 Hasselbeck et al.
 4,070,888 A 1/1978 Gombas
 4,120,190 A 10/1978 Schlau et al.
 4,341,103 A 7/1982 Escallon et al.
 4,428,474 A 1/1984 Gau et al.
 4,487,048 A 12/1984 Frei
 4,497,409 A 2/1985 Chong
 4,625,541 A 12/1986 Jones et al.
 4,723,430 A 2/1988 Hahn
 4,901,557 A 2/1990 Schmidt
 5,035,569 A 7/1991 Alznauer
 5,058,724 A 10/1991 Hinton
 5,078,564 A 1/1992 Zago
 5,121,620 A 6/1992 Haulsee
 5,150,594 A 9/1992 Pazzaglia
 5,253,500 A 10/1993 Willoughby
 5,341,667 A 8/1994 Lee, Jr.
 5,415,268 A 5/1995 Lofgren
 5,448,903 A 9/1995 Johnson
 5,467,628 A 11/1995 Bowlin et al.
 5,727,414 A 3/1998 Halasz et al.
 5,761,942 A 6/1998 Johnson et al.
 5,768,931 A 6/1998 Gombas
 5,799,525 A 9/1998 Johnson et al.
 5,810,955 A 9/1998 Seifert et al.

5,893,286 A 4/1999 Johnson et al.
 5,899,104 A 5/1999 Brillman et al.
 5,916,317 A 6/1999 Willoughby et al.
 5,941,109 A 8/1999 Johnson et al.
 6,009,733 A 1/2000 Cheers et al.
 6,279,445 B1 8/2001 Rosene et al.
 6,338,263 B1 1/2002 Obata et al.
 6,572,327 B1 6/2003 Ball et al.
 6,651,800 B2 11/2003 Baclija et al.
 6,868,652 B2 3/2005 Arends et al.
 7,003,999 B2 2/2006 Campo et al.
 7,004,000 B2 2/2006 Campo et al.
 7,024,912 B2 4/2006 Campo et al.
 7,398,665 B2 * 7/2008 Campo et al. 72/17.3
 8,245,556 B2 * 8/2012 Campo et al. 72/379.4

FOREIGN PATENT DOCUMENTS

EP 0852972 7/1998
 EP 0893175 1/1999
 EP 1214991 6/2002
 EP 1214994 6/2002
 GB 778545 7/1957
 GB 1384184 2/1975
 GB 1408091 10/1975
 JP 11156463 6/1999
 WO WO95/15227 6/1995
 WO WO97/21505 6/1997
 WO WO98/03279 1/1998
 WO WO98/03280 1/1998

* cited by examiner

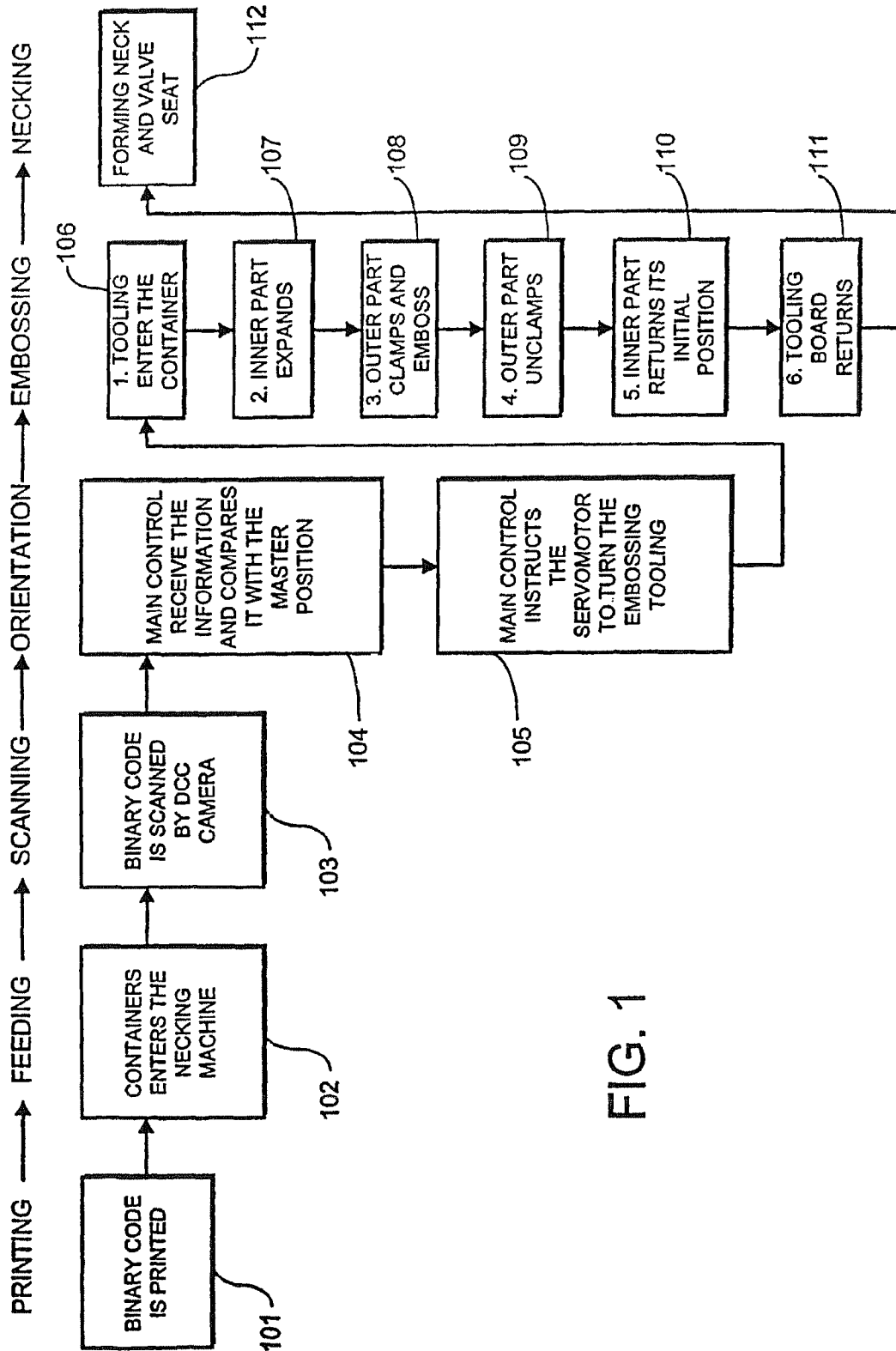

FIG. 1

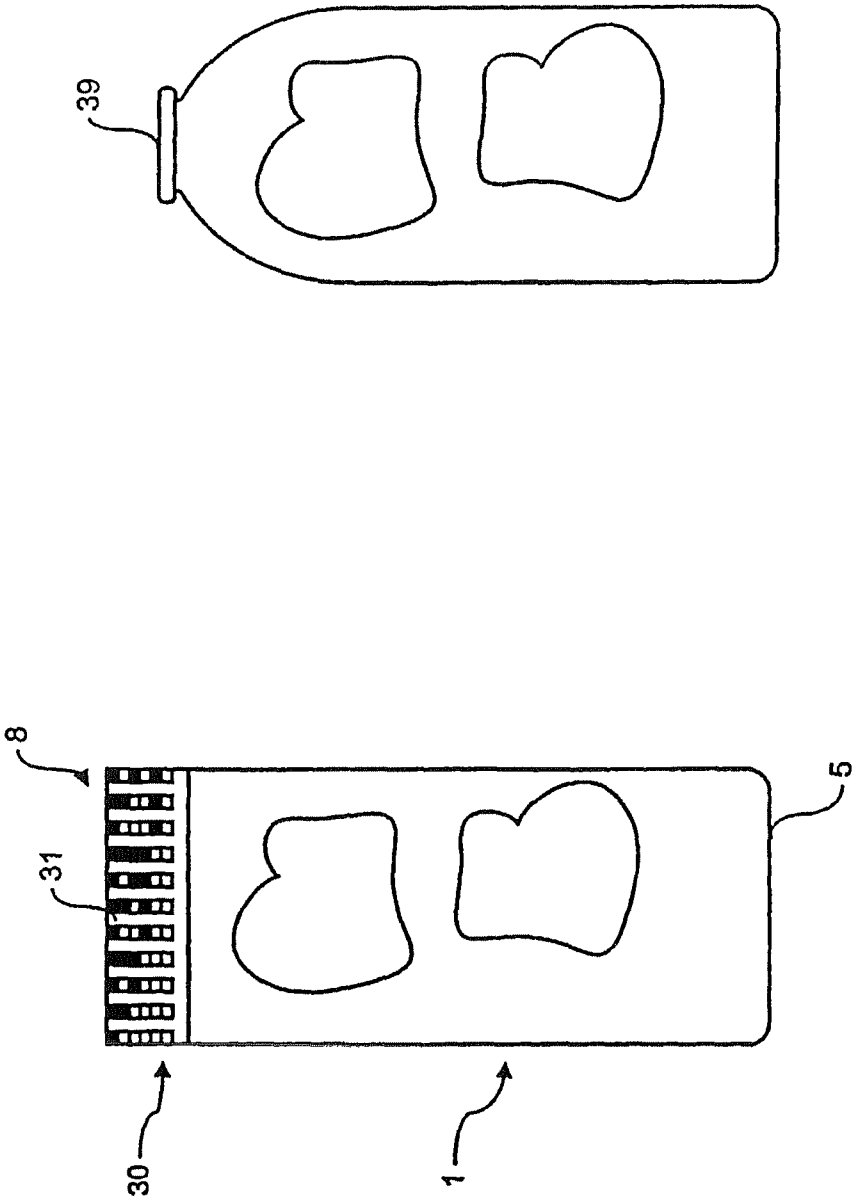

FIG. 3

FIG. 2

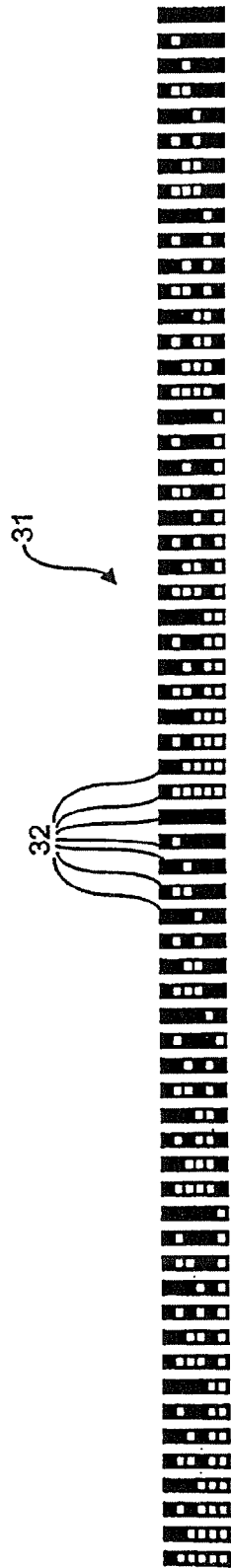

FIG. 4

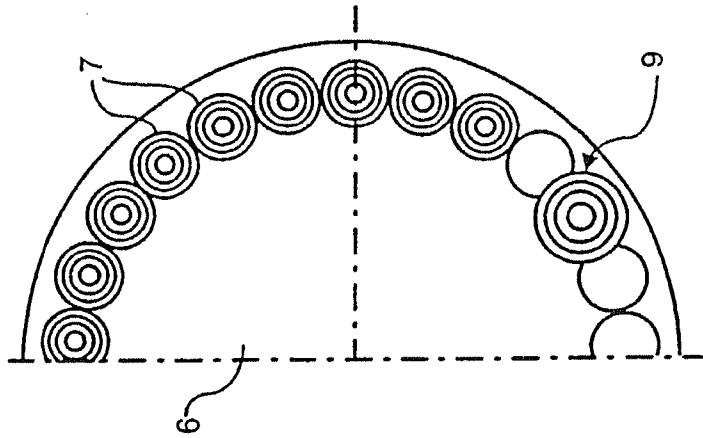

FIG. 7

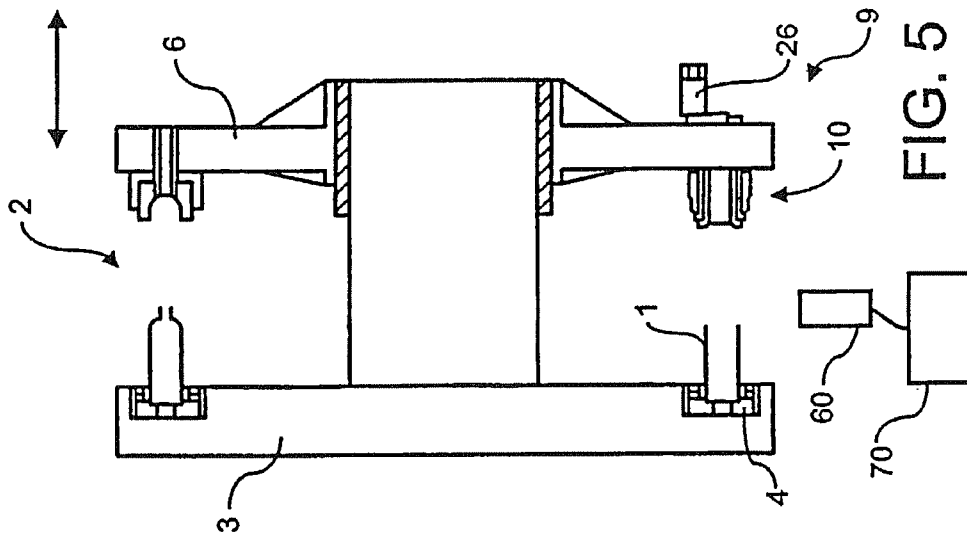

FIG. 5

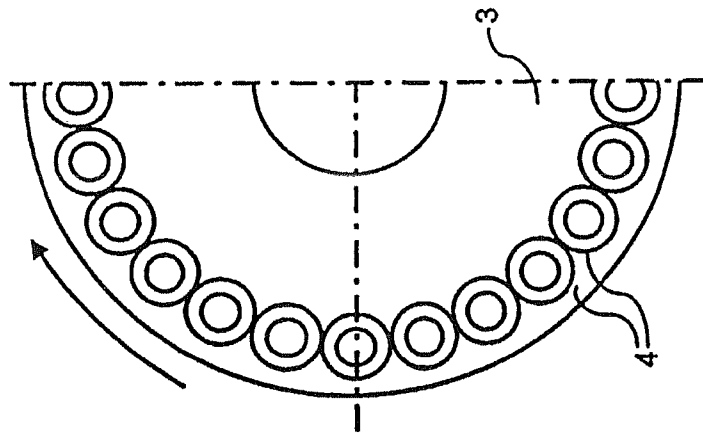

FIG. 6

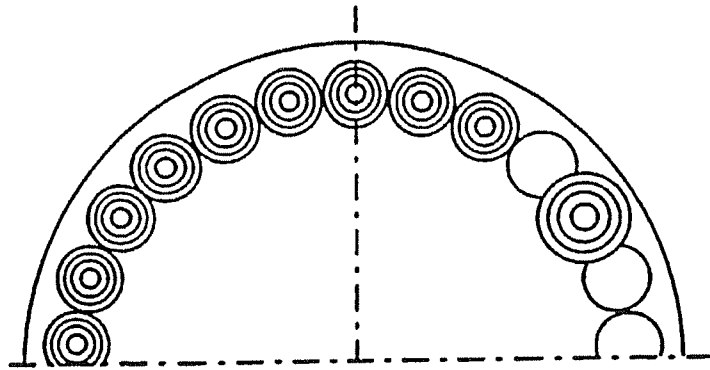

FIG. 10

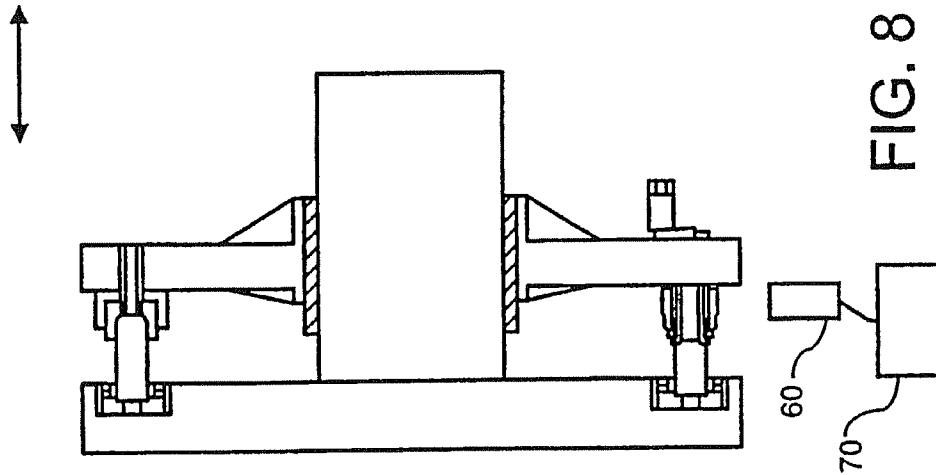

FIG. 8

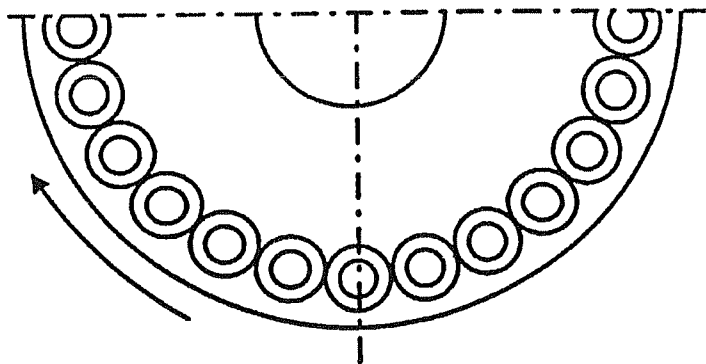

FIG. 9

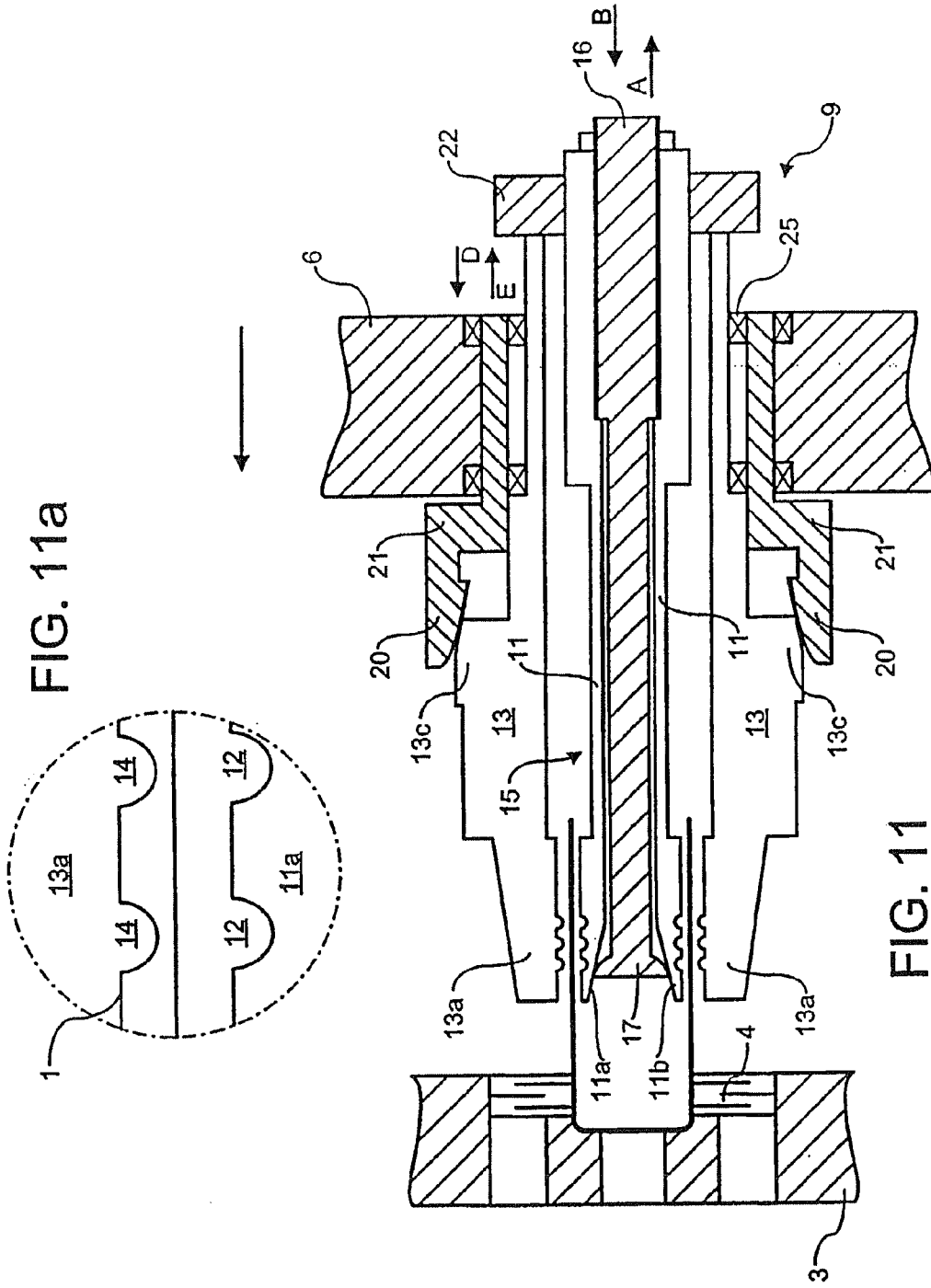

FIG. 11a

FIG. 11

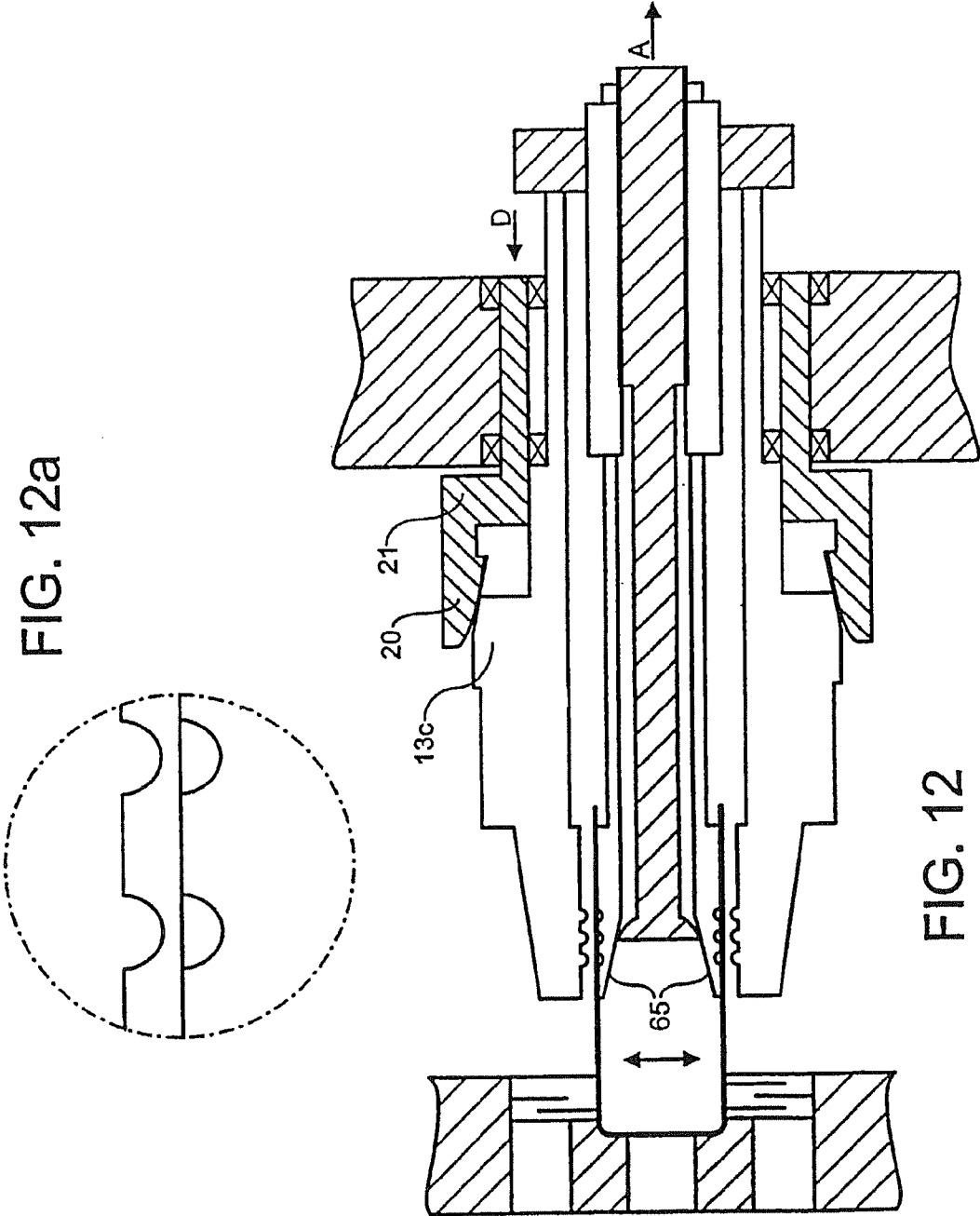

FIG. 12a

FIG. 12

FIG. 13a

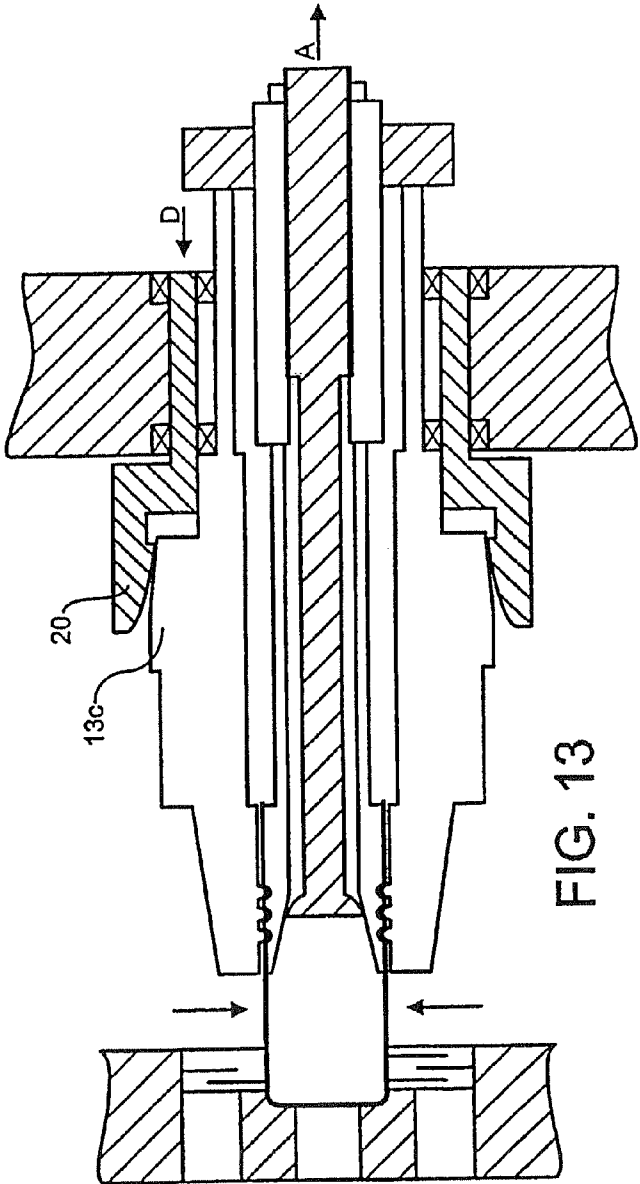
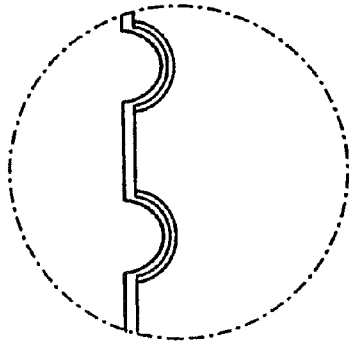

FIG. 13

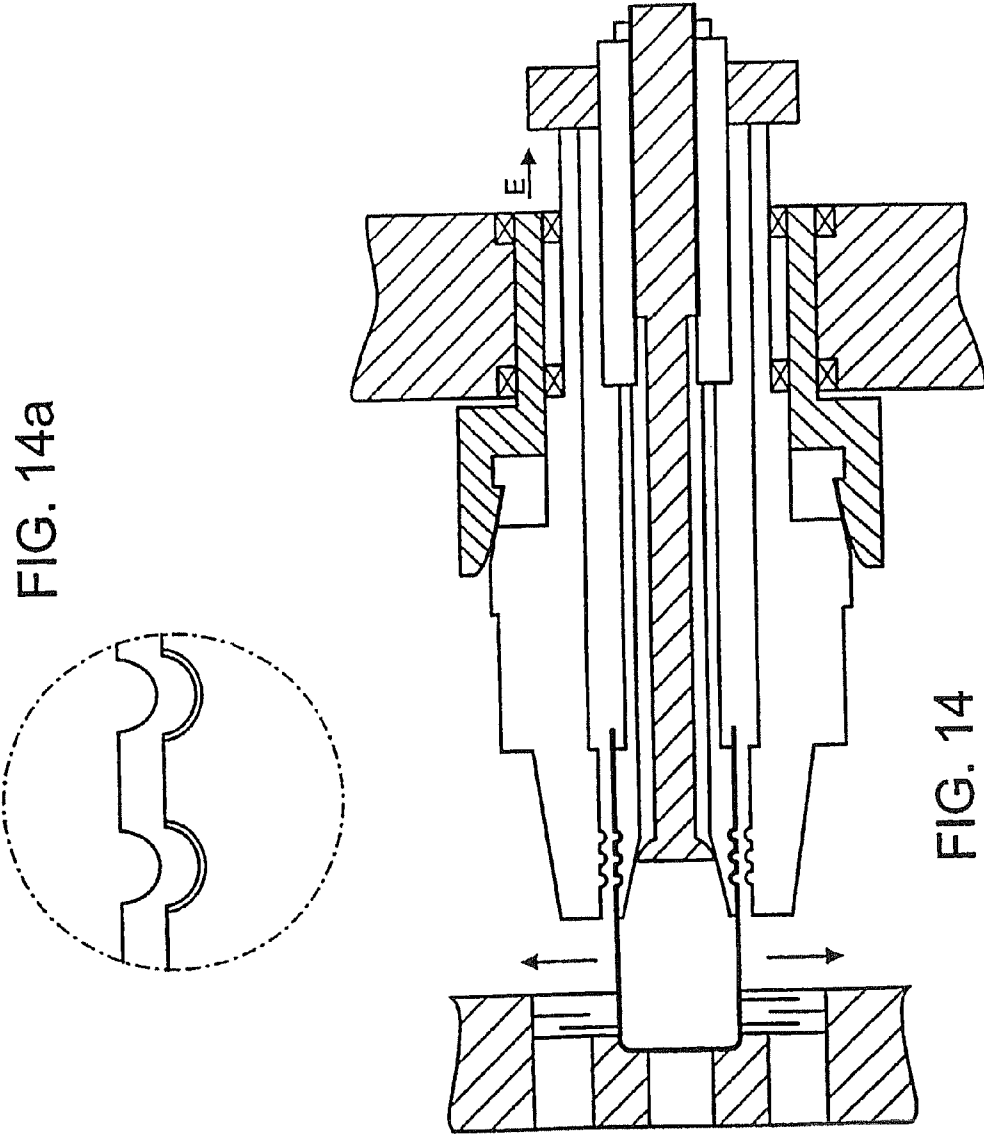

FIG. 14a

FIG. 14

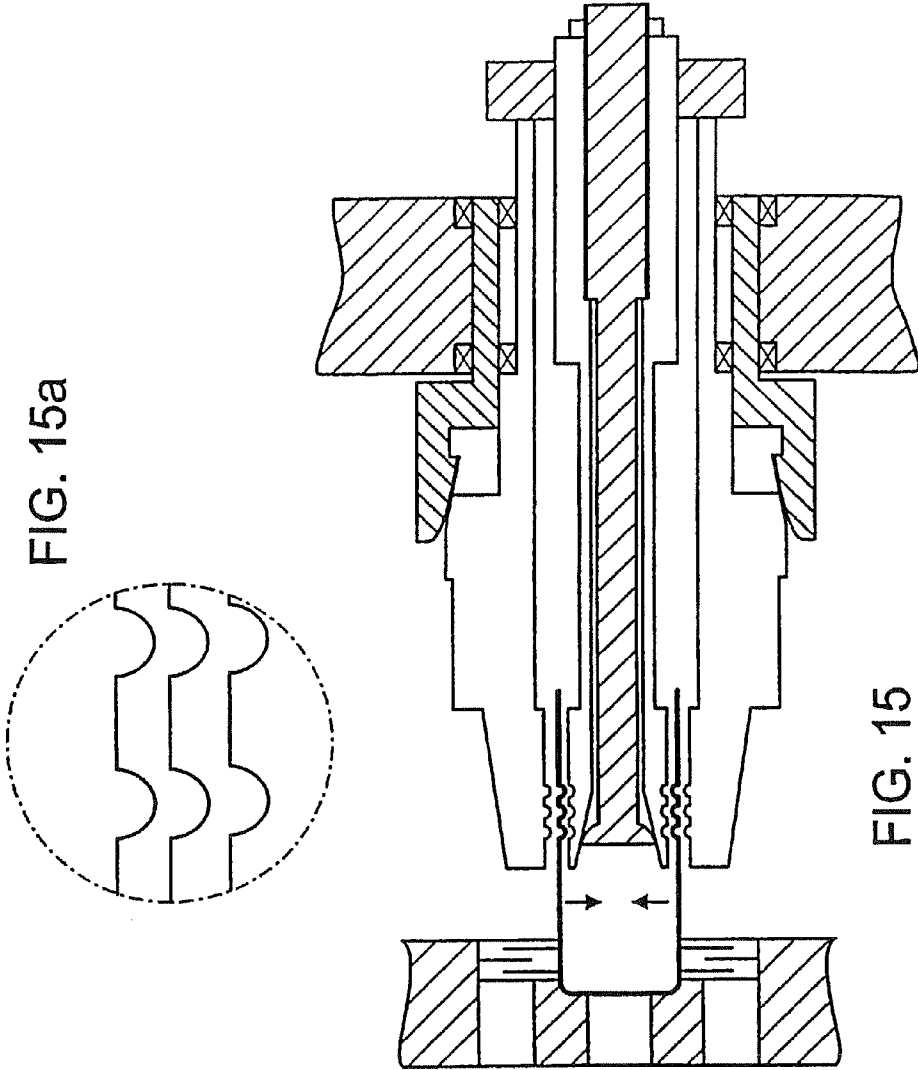

FIG. 15a

FIG. 15

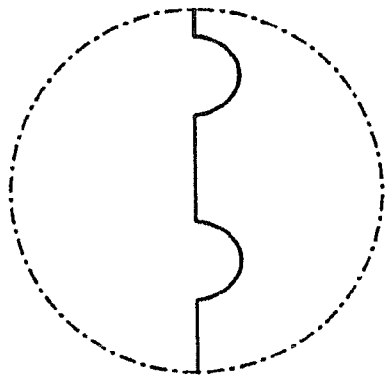

FIG. 16a

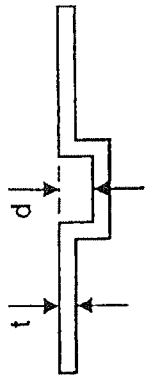

FIG. 17

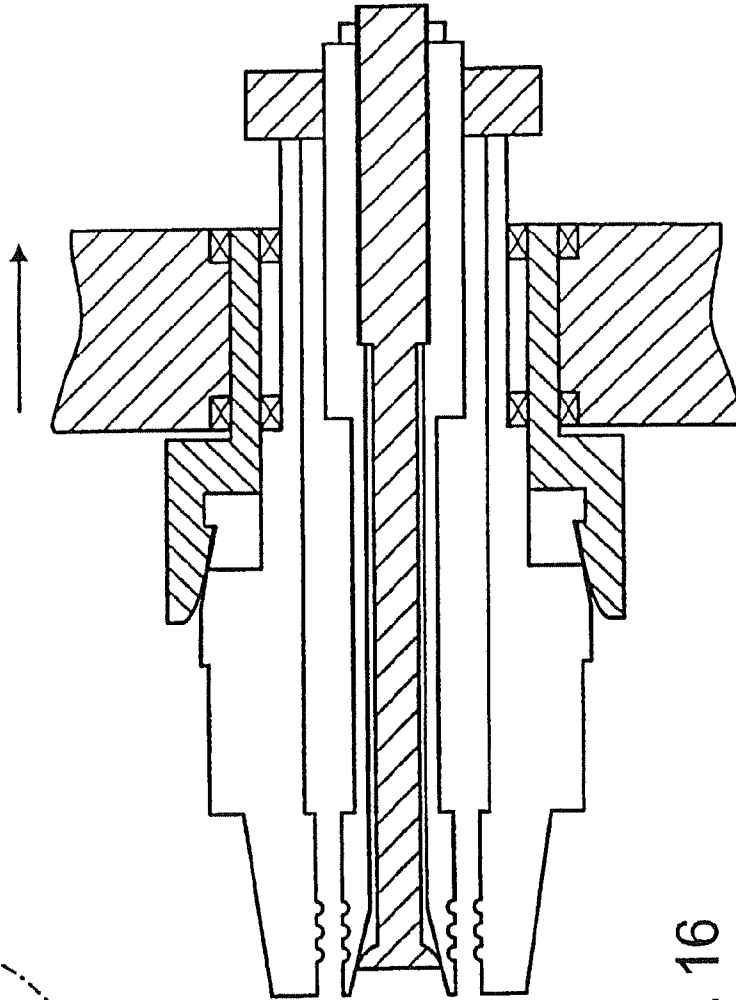
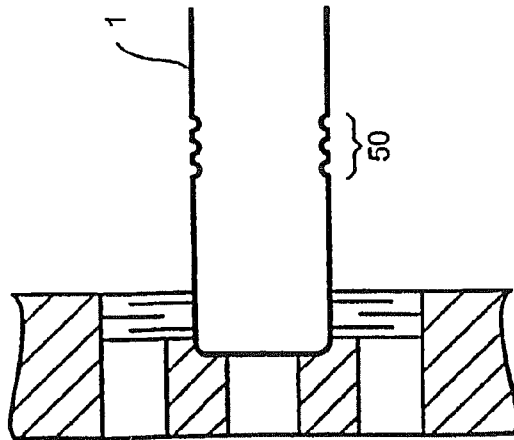

FIG. 16



DEFORMATION OF THIN WALLED BODIES**CROSS-REFERENCE TO RELATED APPLICATIONS**

The present application is a continuation of U.S. application Ser. No. 12/900,864, filed Oct. 8, 2010, to be issued as U.S. Pat. No. 8,245,556, which is a continuation of U.S. application Ser. No. 12/564,807, filed Sep. 22, 2009, now abandoned, which is a continuation of U.S. application Ser. No. 12/114,416, filed May 2, 2008, now abandoned, which is a continuation of U.S. application Ser. No. 11/314,630, filed Dec. 21, 2005, now U.S. Pat. No. 7,398,665, which is a continuation of U.S. application Ser. No. 10/182,643, filed Sep. 30, 2002, now U.S. Pat. No. 7,003,999, all of which are related to PCT Application No. PCT/GB01/00526, filed Feb. 9, 2001, G.B. Application No. 0003033.8, filed Feb. 10, 2000, and G.B. Application No. 0026325.1, filed Oct. 27, 2000, all of which are incorporated herein by reference in their entireties.

BACKGROUND OF THE INVENTION**1. Field of the Invention**

The present invention relates to deformation of generally thin walled bodies, particularly thin walled containers or tube-form bodies which may be of cylindrical or other form.

The invention is particularly suited to embossing of thin walled metallic bodies (particularly aluminium containers) by embossing or the like. More specifically the invention may be used in processes such as registered embossing of thin walled bodies, particularly registered embossing of containers having pre-applied (pre-printed) surface decoration.

2. State of the Art

It is known to be desirable to deform by embossing or the like the external cylindrical walls of metallic containers such as aluminium containers. In particular attempts have been made to emboss the walls of containers at predetermined locations to complement a printed design on the external surface of such a container. In such techniques it is important to coordinate the embossing tooling with the preprinted design on the container wall. Prior art proposals disclose the use of a scanning system to identify the position of the container relative to a datum position and reorientation of the container to conform to the datum position.

Prior art embossing techniques and apparatus are disclosed in, for example, WO-A-9803280, WO-A-9803279, WO-A-9721505 and WO-A-9515227. Commonly in such techniques the container is loaded into an internal tool which acts to support the container and also co-operate with an external tool in order to effect embossing. Such systems have disadvantages, as will become apparent from the following.

SUMMARY OF THE INVENTION

An improved technique has now been devised.

According to a first aspect, the present invention provides a method of deforming a thin walled body, the method comprising:

- i) holding the body gripped securely at a holding station;
- ii) engaging tooling to deform the wall of the body at a predetermined wall zone, the tooling being provided at a tooling station which is adjacent the holding station during deformation;

wherein the predetermined wall zone is co-aligned with the tooling by means of co-ordinated movement of the tooling prior to deforming engagement with the wall of the body.

According to a further aspect, the invention provides apparatus for deforming a thin walled body, the apparatus including:

- i) a holding station for holding the body gripped securely;
 - ii) a tooling station including tooling to deform the body at a predetermined wall zone of the body, the tooling station being positioned at a location adjacent the holding station during deformation;
 - iii) determination means for determining the orientation of the cylindrical body relative to a reference (datum) situation;
 - iv) means for co-ordinated movement to reconfigure the tooling to co-align with the predetermined wall zone prior to deforming engagement of the tooling with the body.
- Co-alignment of the tooling and the wall zone of the body is typically required in order to ensure that embossing deformation accurately lines up with pre-printed decoration on the body. In the technique of the present invention, the body is not passed from being supported at a holding station to being supported by the tooling but, by contrast, remains supported at the holding station throughout the deforming process.

Re-configuration of the tooling avoids the requirement for the or each holding or clamping station to have the facility to re-orientate a respective body.

The technique is particularly suited to embossing containers having wall thicknesses(t) in the range 0.25 mm to 0.8 mm (particularly in the range 0.35 mm to 0.6 mm). The technique is applicable to containers of aluminium including alloys, steel, tinplate steel, internally polymer laminated or lacquered metallic containers, or containers of other materials. Typically the containers will be cylindrical and the deformed embossed zone will be co-ordinated with a pre-printed/pre-applied design on the circumferential walls. Typical diameters of containers with which the invention is concerned will be in the range 35 mm to 74 mm although containers of diameters outside this range are also susceptible to the invention.

Beneficially the tooling will be re-configurable by rotation of the tooling about a rotational tooling axis to co-align with the predetermined wall zone.

The determination means preferably dictates the operation of the tooling rotation means to move/rotate the tooling to the datum position. The determination means preferably determines a shortest rotational path (clockwise or anti-clockwise) to the datum position and triggers rotation of the tooling in the appropriate sense.

The length of time available to perform the steps of re-orientation and deformation is relatively short for typical production runs which may process bodies at speeds of up to 200 containers per minute. Re-orientation of the tooling (particularly by rotation of the tooling about an axis) enables the desired re-orientation to be achieved in the limited time available. The facility to re-orientate clockwise or anti-clockwise following sensing of the container orientation and shortest route to the datum position is particularly advantageous in achieving the process duration times required.

According to a further aspect, the invention provides apparatus for use in deforming a wall zone of a thin walled container, the apparatus comprising internal tooling to be positioned internally of the container, and external tooling to be positioned externally of the container, the external and internal tooling co-operating in a forming operation to deform the wall zone of the container, the internal tooling being moveable toward and away from the centreline or axis of the container between a retraction/insertion tooling configuration in which the internal tool can be inserted or retracted

from the interior of the container, to a wall engaging configuration for effecting deforming of the wall zone.

Correspondingly a further aspect of the invention provides a method of deforming a thin walled container, the method comprising:

inserting internal tooling into the interior of the container, the internal tooling being in a first, insertion configuration for insertion;

moving the tooling to a second, (preferably expanded) position or configuration closely adjacent or engaging the internal container wall so as to facilitate deformation of a wall zone of the container;

returning the tooling from the second position toward the first tooling configuration thereby to permit retraction of the internal tooling from the container.

Because the internal tooling is movable toward and away from the container wall (preferably toward and away from the axis/centreline of the container), embossed relief features of greater depth/height can be produced. This is because prior art techniques generally use an internal tool which also serves to hold the container during deformation (embossing) and therefore typically only slight clearance between the internal tool diameter and the internal diameter of the container has been the standard practice.

In accordance with the broadest aspect of the invention, the relief pattern for embossing may be carried on cam portions of internal and/or external tools, the eccentric rotation causing the cam portions to matingly emboss the relevant portion of the container wall.

A particular benefit of the present invention is that it enables a greater area of the container wall (greater dimension in the circumferential direction) to be embossed than is possible with prior art techniques where the emboss design would need to be present on a smaller area of the tool. Rotating/cam-form tooling, for example, has the disadvantage of having only a small potential area for design embossing.

Re-configurable, particularly collapsible/expandable internal tooling provides that greater depth/height embossing formations can be provided, the internal tooling being collapsed from engagement with the embossed zone and subsequently retracted axially from the interior of the container.

Embossed feature depth/height dimensions in the range 0.5 mm and above (even 0.6 mm to 1.2 mm and above) are possible which have not been achievable with prior art techniques.

According to a further aspect, the invention provides apparatus for use in deforming the cylindrical wall of a thin walled cylindrical container, the apparatus comprising an internal tooling part to be positioned internally of the container, and an external tooling part to be positioned externally of the container, the external and internal tools co-operating in a forming operation to deform a portion of the cylindrical container wall therebetween; wherein tooling actuation means is provided such that:

(a) the external and internal tools are movable independently of one another to deform the container wall; and/or

(b) deforming force applied to the external and internal tools is positioned at force action zones spaced at opposed sides of the zone of the container wall to be deformed.

As described above, the technique of the invention is particularly suited to embossing containers having relatively thick wall thickness dimensions (for example in the range 0.35 mm to 0.8 mm). Such thick walled cans are suitable for containing pressurised aerosol consumable products stored at relatively high pressures. Prior art techniques have not been

found to be suitable to successfully emboss such thicker containers, nor to produce the aesthetically pleasing larger dimensioned emboss features as is capable with the present invention (typically in the range 0.3 mm to 1.2 mm depth/height).

The technique has also made it possible to emboss containers (such as seamless monobloc aluminium containers) provided with protective/anti-corrosive internal coatings or layers without damage to the internal coating or layer.

According to a further aspect, the invention therefore provides an embossed container or tube-form product, the product comprising a product side-wall having a thickness substantially in the range 0.25 mm to 0.8 mm and a registered embossed wall zone, the embossed deformation having an emboss form depth/height dimension substantially in the range 0.3 mm to 1.2 mm or above.

Preferred features of the invention are defined in the appended claims and readily apparent from the following description. The various features identified and defined as separate aspects herein are also mutually beneficial and may be beneficially included in combination with one another.

BRIEF DESCRIPTION OF THE DRAWINGS

The invention will now be further described in a specific embodiment, by way of example only, and with reference to the accompanying drawings, in which:

FIG. 1 is a flow diagram of a process according to the invention;

FIG. 2 is a view of a container to be operated upon in accordance with the invention;

FIG. 3 is a side view of the container of FIG. 2 in a finish formed state;

FIG. 4 is a 360 degree view of a positional code in accordance with the invention;

FIG. 5 is a schematic side view of apparatus in accordance with the invention;

FIGS. 6 and 7 are half plan views of apparatus components of FIG. 5;

FIGS. 8, 9 and 10 correspond to the views of FIGS. 5, 6 and 7 with components in a different operational orientation;

FIG. 11 is a schematic close up sectional view of the apparatus of the preceding figures in a first stage of the forming process;

FIG. 11a is a detail view of the forming tools and the container wall in the stage of operation of FIG. 11;

FIGS. 12, 12a to 16, 16a correspond to the views of FIGS. 11 and 11a; and

FIG. 17 is a schematic sectional view of an embossed zone of a container wall in accordance with the invention.

DETAILED DESCRIPTION OF THE PREFERRED EMBODIMENTS

Referring to the drawings the apparatus and technique is directed to plastically deforming (embossing or debossing) the circumferential wall of an aluminium container 1 at a predetermined position relative to a preprinted decorative design on the external container wall. Where the embossing deformation is intended to coincide with the printed decorative design, this is referred to in the art as Registered Embossing.

In the embodiment shown in the drawings, a design 50 comprising a series of three axially spaced arc grooves is to be embossed at 180 degree opposed locations on the container wall (see FIG. 16a). For aesthetic reasons it is important that the location at which the design 50 is embossed is coordinated

5

with the printed design on the container **1** wall. Coordination of the container **1** axial orientation with the tooling to effect deformation is therefore crucial.

Referring to FIGS. **5** to **7** the forming apparatus **2** comprises a vertically orientated rotary table **3** operated to rotate (about a horizontal axis) in an indexed fashion to successively rotationally advanced locations. Spaced around the periphery of table **3** are a series of container holding stations comprising clamping chucks **4**. Containers are delivered in sequence to the table in random axial orientations, each being received in a respective chuck **4**, securely clamped about the container base **5**.

A vertically orientated forming table **6** faces the rotary table **3** and carries a series of deformation tools at spaced tooling stations **7**. Following successive rotary index movements of rotary table **3**, table **6** is advanced from a retracted position (FIG. **5**) to an advanced position (FIG. **8**). In moving to the advanced position the respective tools at tooling stations **7** perform forming operations on the container circumferential walls proximate their respective open ends **8**. Successive tooling stations **7** perform successive degrees of deformation in the process. This process is well known and used in the prior art and is frequently known as necking. Necked designs of various neck/shoulder profiles such as that shown in FIG. **3** can be produced.

Necking apparatus typically operates at speeds of up to 200 containers per minute giving a typical working time duration at each forming station in the order of 0.3 seconds. In this time, it is required that the tooling table **6** moves axially to the advanced position, the tooling at a respective station contacts a respective container and deforms one stage in the necking process, and the tooling table **6** is retracted.

In accordance with the invention, in addition to the necking/shoulder-forming tooling at stations **7**, the tooling table carries embossing tooling **10** at an embossing station **9**. The embossing tooling (shown most clearly in FIGS. **11** to **16**) comprises inner forming tool parts **11a**, **11b** of respective arms **11** of an expandible internal tool mandrel **15**. Tool parts **11a**, **11b** carry respective female embossing formations **12**.

The embossing tooling **10** also includes a respective outer tool arrangement including respective arms **13** carrying tooling parts **13a**, **13b** having complementary male embossing formations **14**. In moving to the table **7** advanced position the respective internal tool parts **11a**, **11b** are positioned internally of the container spaced adjacently the container **1** wall; the respective external tool parts **13a**, **13b** are positioned externally of the container spaced adjacently the container **1** wall.

The internal mandrel **15** is expandible to move the tooling parts **11a**, **11b** to a relatively spaced apart position in which they abut the internal wall of the container **1** (see FIG. **12**) from the collapsed position shown in FIG. **11** (tools **11a**, **11b** spaced from the internal wall of the container **1**). An elongate actuator rod **16** is movable in a longitudinal direction to effect expansion and contraction of the mandrel **15** and consequent movement apart and toward one another of the tool parts **11a**, **11b**. A cam head portion **17** of the actuator rod **16** effects expansion of the mandrel **15** as the actuator rod **16** moves in the direction of arrow A. The cam head portion **17** acts against sloping wedge surfaces **65** of the tool parts **11a**, **11b** to cause expansion (moving apart) of the tool parts **11a**, **11b**. The resilience of arms **11** biases the mandrel **15** to the closed position as the rod **16** moves in the direction of arrow B.

Outer tool arms **13** are movable toward and away from one another under the influence of closing cam arms **20** of actuator **21** acting on a cam shoulder **13c** of respective arms **13**.

6

Movement of actuator **21** in the direction of arrow D causes the external tooling parts **13a** to be drawn toward one another. Movement of actuator **21** in the direction of arrow E causes the external tool parts **13a** to relatively separate. Arms **13** and **11** of the outer tool arrangement and the inner mandrel are retained by cam support ring **22**. The arms **11**, **13** resiliently flex relative to the support ring **22** as the actuators **21**, **16** operate.

As an alternative to the cam/wedge actuation arrangement, other actuators may be used such as hydraulic/pneumatic, electromagnetic (e.g. solenoid actuators) electrical (servo/stepping) motors.

The operation of the embossing tooling is such that the internal mandrel **15** is operable to expand and contract independently of the operation of the external tool parts **13a**.

The internal mandrel **15** (comprising arms **11**) and the external tooling (comprising arms **13**) connected at cam support ring **22**, are rotatable relative to table **6**, in unison about the axis of mandrel **15**. Bearings **25** are provided for this purpose. A servo-motor (or stepping motor) **26** is connected via appropriate gearing to effect controlled rotation of the tooling **10** relative to table **6** in a manner that will be explained in detail later.

With the tooling **10** in the position shown in FIG. **11**, the mandrel **15** is expanded by moving actuator rod **16** in the direction of arrow A causing the internal tooling parts **11a** to lie against the internal circumferential wall of cylinder **1**, adopting the configuration shown in FIGS. **12**, **12a**. Next actuator **21** moves in the direction of arrow D causing cam arms **20** to act on cam shoulder **13c** and flexing arms **13** toward one another. In so doing the external tooling parts **13a** engage the cylindrical wall of container **1**, projections **14** deforming the material of the container **1** wall into respective complementary receiving formations **12** on the internal tooling parts **11a**.

The deforming tooling parts **11a**, **13a**, can be hard, tool steel components or formed of other materials. In certain embodiments one or other of the tooling parts may comprise a conformable material such as plastics, polymeric material or the like.

An important feature is that the internal tooling parts **11a** support the non deforming parts of the container wall during deformation to form the embossed pattern **50**. At this stage in the procedure, the situation is as shown in FIGS. **13**, **13a**. The configuration and arrangement of the cam arms **20**, cam shoulders **13c** of the external embossing tooling and the sloping (or wedge) cam surface of internal tooling parts **11a** (cooperating with the cam head **17** of rod **16**) provide that the embossing force characteristics of the arrangement can be controlled to ensure even embossing over the entire area of the embossed pattern **50**. The external cam force action on the outer tool parts **13a** is rearward of the embossing formations **14**; the internal cam force action on the inner tool parts **11a** is forward of the embossing formations **12**. The forces balance out to provide a final embossed pattern of consistent depth formations over the entire zone of the embossed pattern **50**.

Next actuator **21** returns to its start position (arrow E) permitting the arms **13** of the external tooling to flex outwardly to their normal position. In so doing tooling parts **13a** disengage from embossing engagement with the container **1** external surface. At this stage in the procedure, the situation is as shown in FIGS. **14**, **14a**.

The next stage in the procedure is for the internal mandrel to collapse moving tooling parts **11a** out of abutment with the internal wall of the cylinder **1**. At this stage in the procedure, the situation is as shown in FIGS. **15**, **15a**.

Finally the tooling table **6** is retracted away from the rotatable table **3** withdrawing the tooling **10** from the container. At this stage in the procedure, the situation is as shown in FIGS. **16, 16a**.

In the embodiment described, the movement of the tools to effect embossing is translational only. It is however feasible to utilise rotational external/internal embossing tooling as is known generally in the prior art.

The rotary table is then indexed rotationally moving the embossed container to adjacent with the next tooling station **7**, and bringing a fresh container into alignment with the embossing tooling **10** at station **9**.

The embossing stages described correspond to stages **106** to **112** in the flow diagram of FIG. **1**.

Prior to the approachment of the embossing tooling **10** to a container **1** clamped at table **3** (FIG. **11** and stage **106** of FIG. **1**) it is important that the container **1** and tooling **10** are accurately rotationally oriented to ensure that the embossed pattern **50** is accurately positioned with respect to the printed design on the exterior of the container.

According to the present invention this is conveniently achieved by reviewing the position of a respective container **1** whilst already securely clamped in a chuck **4** of the rotary table **3**, and rotationally reorientating the embossing tooling **10** to the required position. This technique is particularly convenient and advantageous because a rotational drive of one arrangement (the embossing tooling **10**) only is required. Chucks **4** can be fixed relative to the table **3** and receive containers in random axial rotational orientations. Moving parts for the apparatus are therefore minimised in number, and reliability of the apparatus is optimised.

The open ends **8** of undeformed containers **1** approaching the apparatus **2** have margins **30** printed with a coded marking band **31** comprising a series of spaced code blocks or strings **32** (shown most clearly in FIG. **4**). Each code block/string **32** comprises a column of six data point zones coloured dark or light according to a predetermined sequence.

With the container **1** clamped in random orientation in a respective chuck **4** a charge coupled device (CCD) camera **60** views a portion of the code in its field of view. The data corresponding to the viewed code is compared with the data stored in a memory (of controller **70**) for the coded band and the position of the can relative to a datum position is ascertained. The degree of rotational realignment required for the embossing tooling **10** to conform to the datum for the respective container is stored in the memory of main apparatus controller **70**. When the respective container **10** is indexed to face the embossing tooling **10** the controller instigates rotational repositioning of the tooling **10** to ensure that embossing occurs at the correct zone on the circumferential surface of the container **1**. The controller **70** when assessing the angular position of the tooling relative to the angular position to be embossed on the container utilises a decision making routine to decide whether clockwise or counterclockwise rotation of the tooling **10** provides the shortest route to the datum position, and initiates the required sense of rotation of servomotor **26** accordingly. This is an important feature of the system in enabling rotation of the tooling to be effected in a short enough time-frame to be accommodated within the indexing interval of the rotating table **3**.

The coding block **32** system is in effect a binary code and provides that the CCD camera device can accurately and clearly read the code and determine the position of the container relative to the tooling **10** datum by viewing a small proportion of the code only (for example two adjacent blocks **32** can have a large number of unique coded configurations). The coding blocks **32** are made up of vertical data point

strings (perpendicular to the direction of extent of the coding band **31**) in each of which there are dark and light data point zones (squares). Each vertical block **32** contains six data point zones. This arrangement has benefits over a conventional bar code arrangement, particularly in an industrial environment where there may be variation in light intensity, mechanical vibrations and like.

As can be seen in FIG. **4**, because the tooling **10** in the exemplary embodiment is arranged to emboss the same pattern at 180 degree spacing, the coding band **31** includes a coding block pattern that repeats over 180 degree spans.

The position determination system and control of rotation of the tooling **10** are represented in blocks **102** to **105** of the flow diagram of FIG. **1**.

The coding band **31** can be conveniently printed contemporaneously with the printing of the design on the exterior of the container. Forming of the neck to produce, for example a valve seat **39** (FIG. **3**) obscures the coding band from view in the finished product.

As an alternative to the optical, panoramic visual sensing of the coding band **31**, a less preferred technique could be to use an alternative visual mark, or a physical mark (e.g. a deformation in the container wall) to be physically sensed.

Referring to FIG. **17**, the technique is particularly switched to forming aesthetically pleasing embossed formations **50** of a greater height/depth dimension(d) (typically in the range 0.3 mm to 1.2 mm) than has been possible with prior art techniques. Additionally, this is possible with containers of greater wall thickness(t) than have been successfully embossed in the past. Prior art techniques have been successful in embossing aluminium material containers of wall thickness 0.075 mm to 0.15 mm. The present technique is capable of embossing aluminium containers of wall thickness above 0.15 mm, for example even in the range 0.25 mm to 0.8 mm. The technique is therefore capable of producing embossed containers for pressurised aerosol dispensed consumer products which has not been possible with prior art techniques. Embossed monobloc seamless aluminium material containers are particularly preferred for such pressurised aerosol dispensed products (typically having a delicate internal anti-corrosive coating or layer protecting the container material from the consumer product). The present invention enables such containers to be embossed (particularly registered embossed).

As an alternative to the technique described above in which the embossing tooling is rotated to conform to the datum situation, immediately prior to the container being placed in the chuck **4** and secured, the position of the container may be optically viewed to determine its orientation relative to the datum situation. If the orientation of the container **1** differs from the desired datum pre-set situation programmed into the system, then the container is rotated automatically about its longitudinal axis to bring the container **1** into the pre-set datum position. With the container in the required datum position, the container is inserted automatically into the clamp **4** of the holding station, and clamped securely. In this way the relative circumferential position of the printed design on the container wall, and the position of the tooling is coordinated. There is, thereafter, no requirement to adjust the relative position of the container and tooling. This technique is however less preferred than the technique primarily described herein in which the embossing tooling **10** is re-oriented.

The invention has primarily been described with respect to embossing aluminium containers of relatively thin wall thicknesses (typically substantially in the range 0.25 mm to 0.8 mm. It will however be readily apparent to those skilled in the

art that the essence of the invention will be applicable to embossing thin walled containers/bodies of other material such as steel, steel tinplate, lacquered plasticised metallic container materials an other non-ferrous or non-metallic materials.

What is claimed is:

1. A method of deforming a thin walled body comprising:

(i) holding the body gripped securely in a holding station of a holding table of a multi-station necking machine; and

(ii) advancing a multi-station tooling table of the necking machine relative to the holding table whilst the body is gripped in the holding station to an advanced position wherein the body engages tooling to deform a peripheral wall of the body at a predetermined wall zone to coordinate with a printed design on the peripheral wall of the body, the tooling being provided at a tooling station which is adjacent the holding station during deformation;

wherein the predetermined wall zone is co-aligned with the tooling by rotation of the body about an axis.

2. A method according to claim 1, wherein:

the body is gripped non rotatably at the holding station.

3. A method according to claim 1, wherein:

the tooling is provided at a tooling station and said tooling station is advanced relative to the holding station, such that an internal tooling part is inserted into the interior of the body and an external tooling part is positioned externally of the body whilst the body is gripped securely at the holding station; and the tooling is operated to engage with and deform the peripheral wall of the body at a predetermined wall zone whilst the body is gripped in a fixed orientation in the holding station; wherein the predetermined wall zone is co-aligned with the tooling by rotation of the body about an axis prior to securing at the holding station in said fixed orientation for deforming of the wall of the body.

4. A method according to claim 1, wherein:

the holding station comprises a holding station of a multi-station holding table and the deformation tooling is provided at a deformation tooling station of a multi-station tooling table, the tooling table and holding table being rotationally indexable relative to one another to bring the bodies in succession to the deformation tooling.

5. A method according to claim 1, wherein:

the body is optically viewed to determine orientation of the body relative to a datum and subsequently rotated about said axis to a datum orientation.

6. A method according to claim 5, wherein:

with the body in the datum orientation, the body is inserted into a clamp of the holding station.

7. Apparatus for deforming thin walled bodies comprising:

i) a multi-station necking machine including a holding table with multiple holding stations for securely gripping the bodies;

ii) a multi-station tooling table advanceable with respect to the holding table, one of the stations of the tooling table comprising a coordinated deformation tooling station including tooling arranged to engage with and deform a given body at a predetermined wall zone on a peripheral wall of the given body whilst the given body is gripped securely in a corresponding holding station, the tooling table being positioned at an advanced position adjacent the holding table for deformation of the given body;

iii) determination means for determining the orientation of the given body relative to a reference datum situation; and

iv) means for co-ordinated movement to reconfigure the given body about an axis of the given body to accord with the datum situation prior to the given body being gripped at the holding station in a fixed orientation for deforming of the peripheral wall of the given body.

8. Apparatus according to claim 7, wherein:

the holding station is configured to grip the given body non-rotatably.

9. Apparatus according to claim 7, wherein:

the tooling comprises an internal tooling part and an external tooling part arranged to engage within the interior and exterior of the given body respectively.

10. Apparatus according to claim 7, further comprising:

v) a multi-station holding table, respective holding stations comprising a respective clamp for clamping securely a respective body; and

vi) a multi-station tooling table being positioned adjacent the holding table, the tooling table and holding table being rotationally indexable relative to one another to bring the bodies in succession to the tooling station for coordinated deformation, the tooling table being advanceable relative to the holding table, a coordinated deformation tooling station of the tooling table including an internal tooling part and an external tooling part arranged to engage within the interior, and on the exterior, of the body respectively, together to deform the body at a predetermined wall zone on the body with reference to a pre-applied design on the wall of the body, whilst the body is clamped securely in the holding station.

11. Apparatus according to claim 7, further comprising: optical viewing means to determine the orientation of the given body relative to the datum situation.

12. Apparatus according to claim 10, wherein:

the tooling table includes a necking station to which the given body is indexed.

* * * * *