

(No Model.)

A. KRANZER. TUBE CUTTER.

No. 560,099.

Patented May 12, 1896.

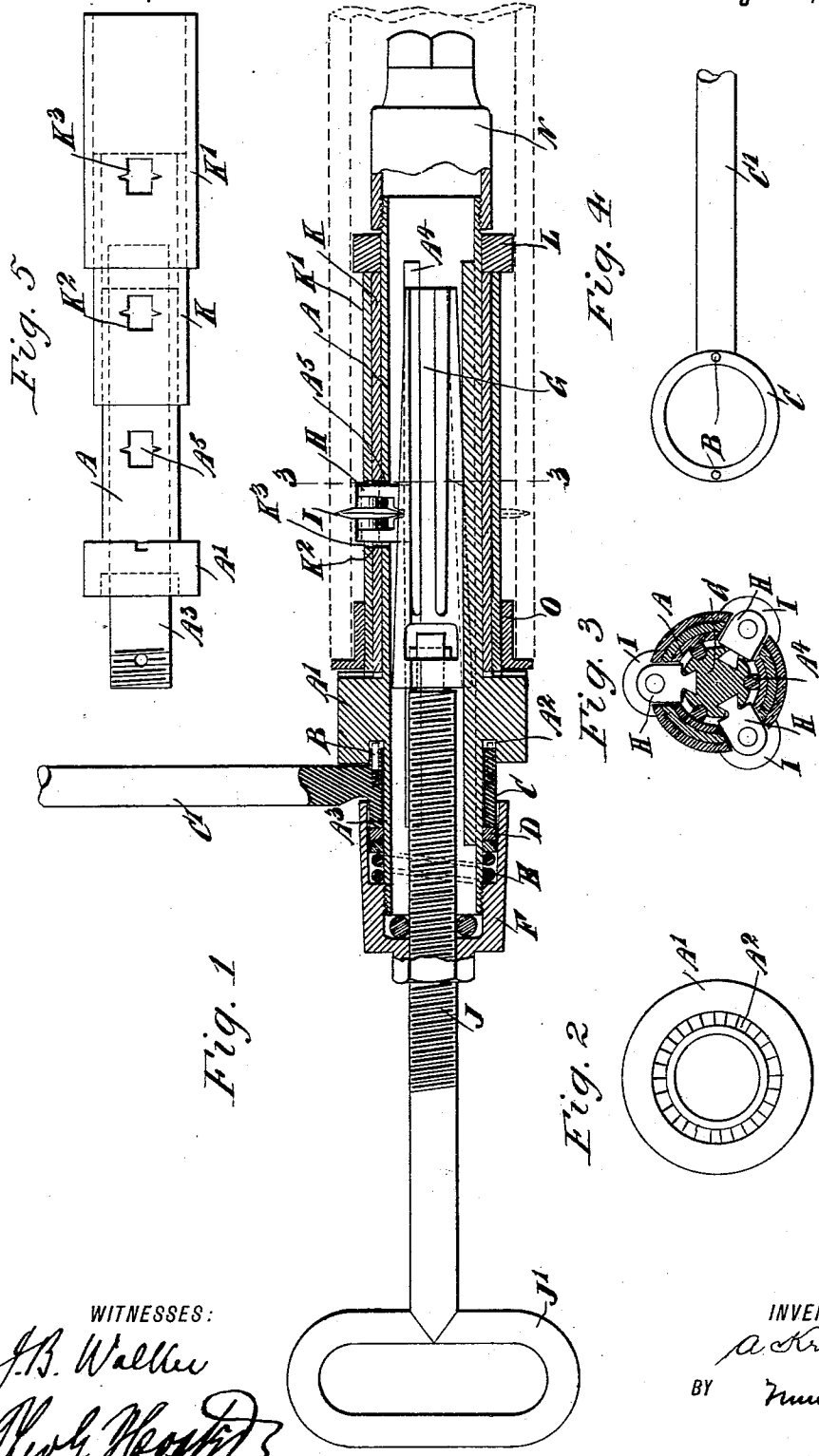

WITNESSES:
J. B. Walker
Thos. H. Wood

INVENTOR
A. Kranzer
 BY *[Signature]*
 ATTORNEYS.

UNITED STATES PATENT OFFICE.

ANTON KRANZER, OF LIDGERWOOD, NORTH DAKOTA, ASSIGNOR OF ONE-HALF TO FRANK DYDRICK, OF SAME PLACE.

TUBE-CUTTER.

SPECIFICATION forming part of Letters Patent No. 560,099, dated May 12, 1896.

Application filed February 11, 1896. Serial No. 578,920. (No model.)

To all whom it may concern:

Be it known that I, ANTON KRANZER, of Lidgerwood, in the county of Richland and State of North Dakota, have invented a new and Improved Tube-Cutter, of which the following is a full, clear, and exact description.

The object of the invention is to provide a new and improved tube and flue cutter which is simple and durable in construction and arranged for conveniently cutting flues and tubes of different diameters.

The invention consists principally of cutting-disk carriers held in a longitudinally-adjustable tapering mandrel and a revoluble apertured casing in which the said carriers are fitted to slide laterally.

The invention also consists of certain parts and details and combinations of the same, as will be fully described hereinafter, and then pointed out in the claims.

Reference is to be had to the accompanying drawings, forming a part of this specification, in which similar characters of reference indicate corresponding parts in all the figures.

Figure 1 is a sectional side elevation of the improvement. Fig. 2 is an end elevation of the casing-head. Fig. 3 is a transverse section of the improvement on the line 3 3 of Fig. 1. Fig. 4 is a face view of the crank-arm; and Fig. 5 is a reduced plan view of the casing, showing the extension-tubes.

The improved tube-cutter is provided with a cylindrical casing A, formed at its inner end with a head A', provided in its face with an annular ratchet-face A², engaged by spring-pressed pins B, held in the hub C of a crank-arm C', mounted to turn with its hub on the reduced end A³, projecting forwardly from the head A'. The crank-arm hub C is engaged by rings D, pressed on by a spring E, held in a cap F, screwing on the outer threaded end of the reduced portion A³ of the casing, so that the spring-pressed pins B readily engage the ratchet-wheel A² on the forward movement of the crank-arm C' to turn the casing and to permit said pins to readily glide over the teeth of the ratchet-wheel on the return stroke of the crank-arm.

On the inside of the casing A are formed longitudinally-extending guideways A⁴, engaging corresponding recesses formed in a

mandrel G, fitted to slide longitudinally in said casing, and provided in its tapering surface with longitudinally-extending dovetailed grooves, in which fit the dovetails of the carriers H, in which the revoluble disk cutters I are journaled. The carriers H each extend through an opening A⁵ in the wall of the casing A, so that the cutting edge of a cutter is adapted to engage the inside of the flue or tube to be cut, said cutter being fed laterally by the operator moving the mandrel G inwardly in a longitudinal direction on screwing up a screw-rod J, screwing in the threaded end of the cap F. The guideways A⁴ serve to take the lateral strain from the carriers when the casing is turned, so as to permit the carriers to move freely along the grooves. By this arrangement it is made possible to readily actuate the feed devices while the casing is being turned in cutting a tube.

The inner end of the screw-rod J is mounted to turn in the base of the mandrel G, and the outer end of said screw-rod is provided with a suitable handle J', adapted to be taken hold of by the operator to turn the said screw-rod and feed the mandrel G inward or outward, as the case may be.

When it is desired to use the instrument for tubes of a diameter considerably larger than the diameter of the casing A, then I employ carriers H, of greater depth, and I also employ a casing-tube K, adapted to slide on the casing A, formed with openings K², registering with the openings A⁵, and the carriers H, of increased depth, extend through the registering openings A⁵ and K² to bring the cutters I in engagement with the inner surface of the tube or flue to be cut. For still larger tubes or flues I slip a second casing-tube K' upon the tube K, and this casing-tube is likewise provided with openings K³, adapted to register with the openings K² and A⁵. Another set of carriers H, of still greater depth, is now employed, so that the carrier extends through the registering openings in the casing A and tubes KK' to bring the cutters I in engagement with the inner surface of the tube or flue.

In order to hold the casing-tubes K and K' in place, I engage the inner ends thereof with a collar L, slipped on the inner end of the

casing A, and this collar is held in place by a cap N, screwing on the threaded inner end of the casing. A flanged collar O is also slipped on the casing A, and larger collars 5 are slipped on the casing-tubes K K' to engage the outer edge of the flue or tube to be cut, as will be readily understood by reference to Fig. 1. Now it will be seen that when the several parts are in the position illustrated in Fig. 1 and the operator manipulates the crank-arm handle C', then a rotary motion is given to the casing A, so that the cutters I cut the tube or flue from the inside, said cutters being fed laterally by shifting the mandrel G inwardly from time to time by 15 the operator turning the feed screw-rod J.

It will be seen that this device is very simple and durable in construction, can be readily manipulated, and conveniently changed for 20 cutting tubes and flues of different diameters.

Having thus fully described my invention, I claim as new and desire to secure by Letters Patent—

1. A tube-cutter comprising a revoluble casing, a ratchet device for turning the same, carriers fitted to slide in the wall of said casing and each carrying a disk cutter, a tapering mandrel engaging said carriers for shifting the same laterally, and a feed-screw rod engaging said mandrel for shifting the latter longitudinally in said casing, substantially as shown and described. 30

2. A tube-cutter comprising a revoluble casing, carriers fitted to slide in the wall of said casing and each carrying a disk cutter, a tapering mandrel engaging said carriers for shifting the same laterally, a feed-screw rod engaging said mandrel for shifting the latter longitudinally in said casing, and auxiliary casing-tubes adapted to be fitted on said casing and having apertures registering with the casing-apertures for the carriers, substantially as shown and described. 35

3. A tube-cutter comprising a revoluble casing, carriers fitted to slide in the wall of said casing and each carrying a disk cutter, a tapering mandrel engaging said carriers for shifting the same laterally, a feed-screw rod engaging said mandrel for shifting the latter longitudinally in said casing, auxiliary casing-tubes adapted to be fitted on said casing and having apertures registering with the casing-apertures for the carriers, and means for holding said auxiliary casing-tubes in 50 place, as set forth.

4. A tube-cutter comprising a casing having a head formed with a ratchet-wheel, a crank-arm mounted to turn on the reduced end of said head and carrying spring-pressed pins engaging said ratchet-wheel, and a spring 60 held in a cap for said casing and pressing said crank-arm, so as to hold the pins in contact with the ratchet-wheel, substantially as shown and described.

5. A tube-cutter comprising a casing formed with apertures in its wall and having longitudinal guideways at its inner surfaces, a tapering mandrel fitted to slide on said guideways and formed with longitudinally-extending dovetailed grooves, a feed-screw rod for 70 moving said mandrel longitudinally in said guideways, and cutter-carriers having dovetails fitting the said grooves of the mandrel, substantially as shown and described.

6. A tube-cutter, comprising a revoluble casing having longitudinal guideways, carriers fitted to slide in the walls of the casing and each carrying a cutter, a tapering mandrel engaging the carriers for shifting the same, said mandrel being guided by engagement 80 with the guideways in the casing, and a feed-screw for moving the mandrel longitudinally in the casing, substantially as set forth.

7. A tube-cutter, comprising a casing having an aperture, carriers fitted to slide in the 85 aperture of the casing and provided with cutters, a tapering mandrel in the casing in engagement with the carriers, for shifting the same, a feed-screw for moving the mandrel, an auxiliary casing-tube arranged to fit on 90 the casing and having an aperture registering with the aperture in the case, and means to secure said tube in place on the casing, substantially as set forth.

8. A tube-cutter, comprising a casing having an aperture, carriers fitted to slide in the 95 aperture of the casing and provided with cutters, a tapering mandrel in the casing in engagement with the carriers, for shifting the same, a feed-screw for moving the mandrel, 100 an auxiliary casing-tube arranged to fit on the casing and having an aperture registering with the aperture in the case, means to secure said tube in place on the casing, and a cap screwing on the end of the casing to hold said 105 tube in place, substantially as set forth.

ANTON KRANZER.

Witnesses:

GEORGE WIRTENBERGER,
H. M. WIRTENBERGER.