

No. 665,935.

Patented Jan. 15, 1901.

A. J. RUDOLPH.
DECORTICATING AND DISINTEGRATING MACHINE.

(Application filed Feb. 1, 1898.)

(No Model.)

4 Sheets—Sheet 1.

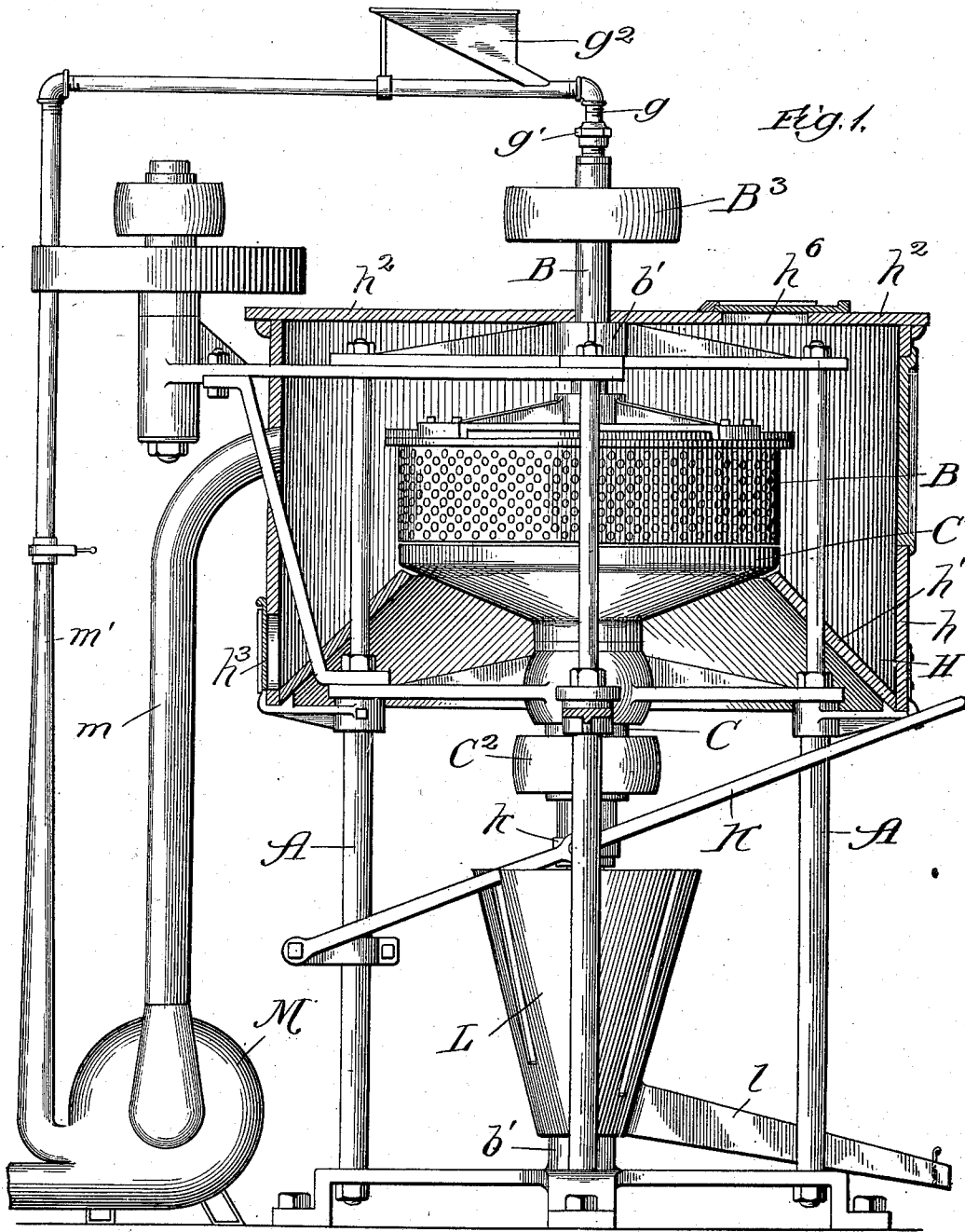

Witnesses:
Chas. S. Chubb
Julius S. Allen

Inventor:
Alexander J. Rudolph
By *Darius P. Dunning* & *Sheldon*
Attys

No. 665,935.

Patented Jan. 15, 1901.

A. J. RUDOLPH.
DECORTICATING AND DISINTEGRATING MACHINE.

(Application filed Feb. 1, 1898.)

(No Model.)

4 Sheets—Sheet 2.

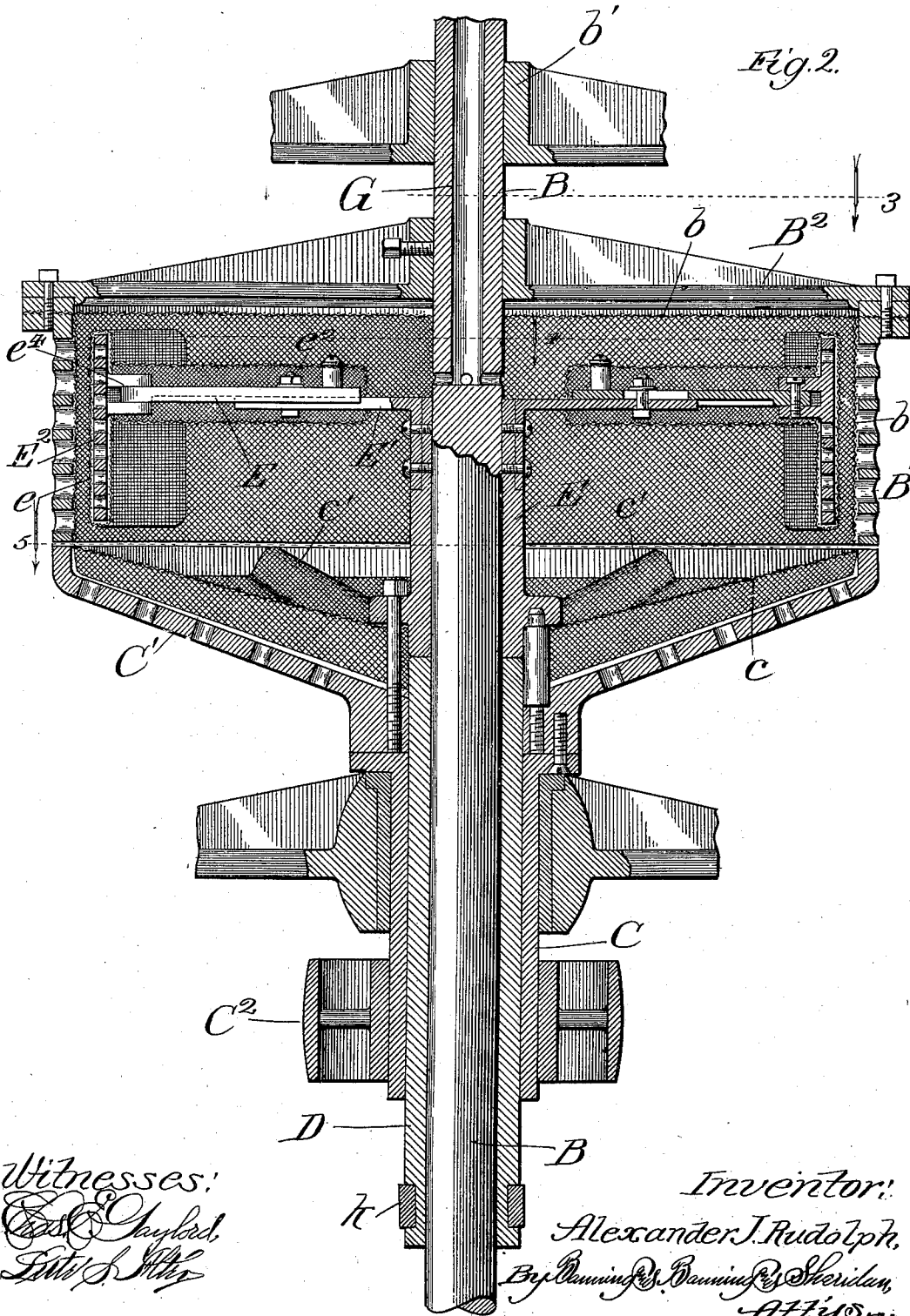

No. 665,935.

Patented Jan. 15, 1901.

A. J. RUDOLPH.
DECORTICATING AND DISINTEGRATING MACHINE.

(Application filed Feb. 1, 1898.)

(No Model.)

4 Sheets—Sheet 3.

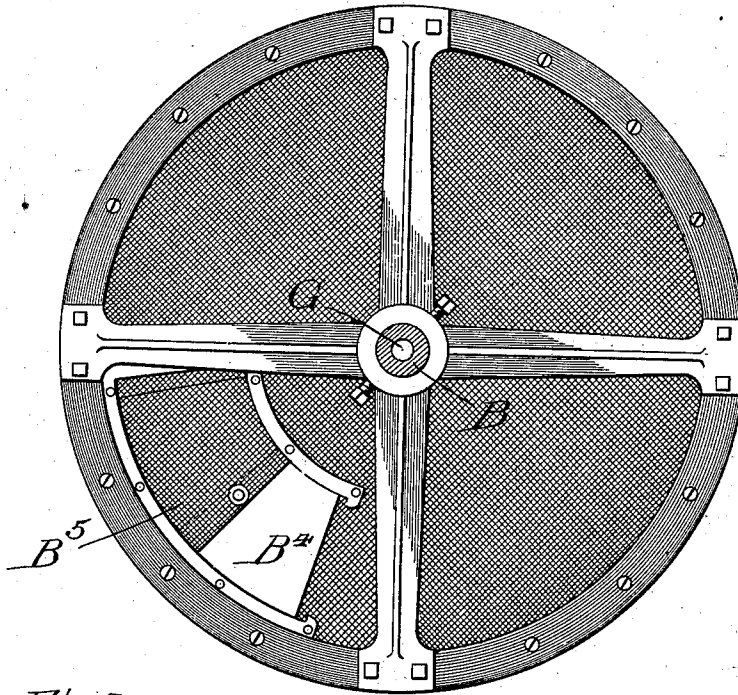
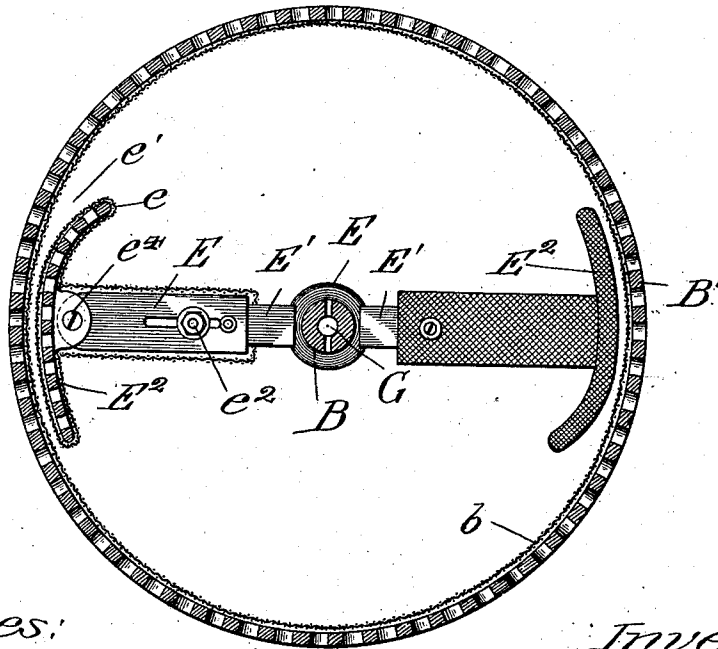

Fig. 3.

Fig. 4.



Witnesses:
Edw. C. Jaylord,
John S. Altus

Inventor:
Alexander J. Rudolph,
 By *Dunning P. Dunning* & *Sheridan*
Attys.

No. 665,935.

Patented Jan. 15, 1901.

A. J. RUDOLPH.
DECORTICATING AND DISINTEGRATING MACHINE.

(Application filed Feb. 1, 1898.)

(No Model.)

4 Sheets—Sheet 4.

Fig. 5.

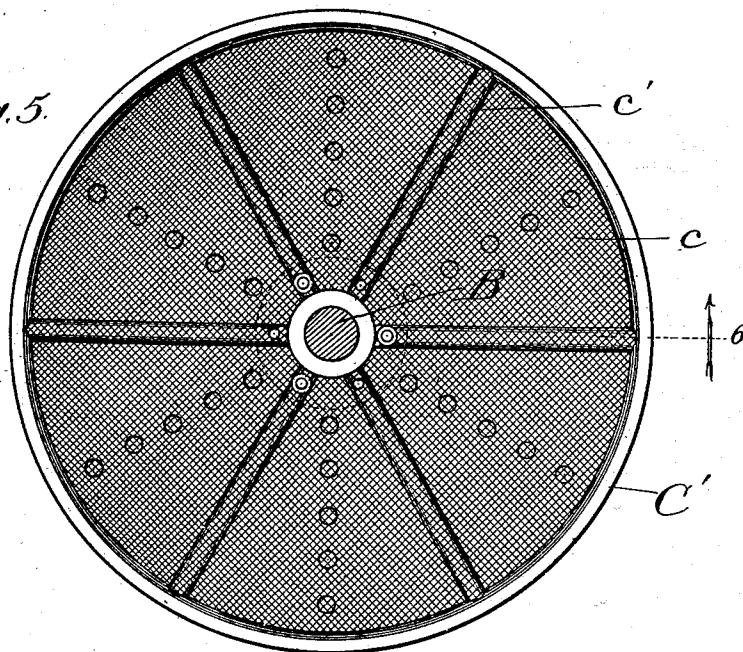
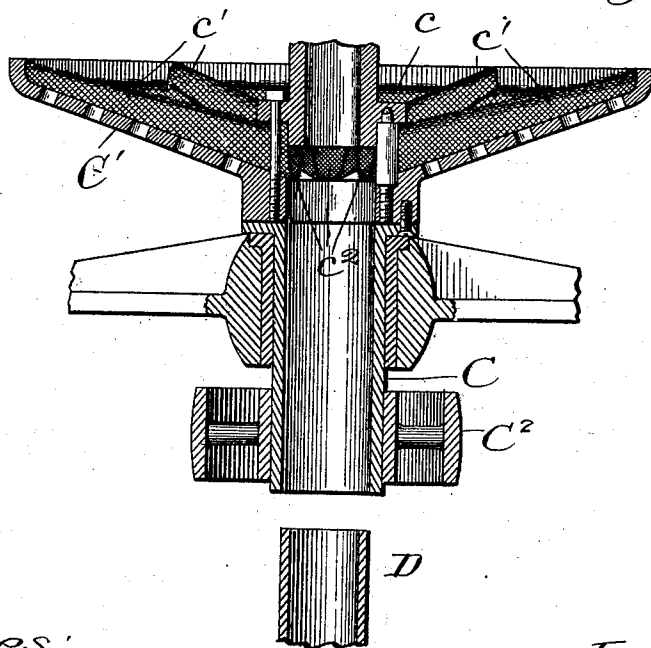

Fig. 6.



Witnesses:
Paul S. Gaylord,
Lulu S. Miller

Inventor:
Alexander J. Rudolph,
By *William D. Manning* & *William S. Sheridan*
ATTYS.

UNITED STATES PATENT OFFICE.

ALEXANDER J. RUDOLPH, OF CHICAGO, ILLINOIS.

DECORTICATING AND DISINTEGRATING MACHINE.

SPECIFICATION forming part of Letters Patent No. 665,935, dated January 15, 1901.

Application filed February 1, 1898. Serial No. 668,705. (No model.)

To all whom it may concern:

Be it known that I, ALEXANDER J. RUDOLPH, a citizen of the United States, residing at Chicago, in the county of Cook and State of Illinois, have invented certain new and useful Improvements in Decortivating and Grinding Machines, of which the following is a specification.

My invention relates particularly to the art of shelling, milling, and grinding cereals and spices—such as wheat, rice, pepper, &c.—and particularly to the methods and processes of removing the shell from the kernel and berry and discharging it, so that they may be obtained in a whole and clean condition for the purposes of storage, shipment, and sale.

The object of my invention is to provide a simple, economical, and efficient method of and apparatus for shelling, milling, and grinding cereals and spices; and the invention consists in the processes, combinations, and details of construction hereinafter described and claimed.

In the accompanying drawings, Figure 1 is an elevation, partly in section, showing one form of apparatus constructed in accordance with my improvements for carrying out my process; Fig. 2, an enlarged central sectional elevation taken at or about the vertical center and showing a portion of the apparatus, as will be hereinafter fully described; Fig. 3, a plan sectional view taken on line 3 of Fig. 2; Fig. 4, a plan sectional view taken on line 4 of Fig. 2 looking in the direction of the arrow; Fig. 5, a plan sectional view taken on line 5 of Fig. 2, and Fig. 6 a cross-sectional elevation taken on line 6 of Fig. 5.

I prefer to illustrate and describe one form of apparatus for carrying out my process and in which my invention may be embodied, and for the sake of clearness and to avoid ambiguity and confusion such apparatus is shown adjusted and arranged for the purpose of shelling wheat or pepper—that is, for removing the outer shell or cover of the wheat and separating it from the kernel and decortivating or removing the outer shell or covering of the pepper-berry. It will be understood, however, that my process and apparatus may be used in connection with all kinds of cereals or spices—such as rice, oats, barley, &c.—by making slight changes or modifica-

tions in the size, form, or arrangement of the parts.

In describing my improvements I will first describe the apparatus as it is used in connection with the process of removing the outer shell or covering from the kernel or berry.

In constructing one style of apparatus for carrying out my process and which embodies my improvements I make a frame having pillars A, adapted to contain and support the operative mechanisms. Mounted on a suitable rotatable shaft B is an outer encircling perforated rotatable grinding-cylinder B', provided with an inner lining of reticulated material *b*, preferably wire mesh, arranged around the cylinder and on the inner surface of the cover B², which is secured to the cylinder. This rotatable shaft is mounted in suitable bearings *b'* in the frame portion and provided with a pulley B³ at the upper end thereof, which can be connected with a suitable driving-wheel for the purpose of giving the required speed or revolution to the grinding-cylinder.

Arranged on a suitable rotatable sleeve C, which encircles a second sleeve or annular gate D, arranged on the rotatable shaft, is a bottom portion C', preferably perforated and also provided with an inner surface of reticulated material *c*. This bottom portion is preferably inclined downwardly and inwardly, so as to facilitate the discharge of the decorticated berries or kernels, and the reticulated surface is preferably provided with ribs *c'*, extending radially from the center portion, so that by the rotation of the bottom portion the ribs act as vanes or fan-blades and create an outward current of air, and these ribs *c'* serve to carry the grain around for the centrifugal force to act in conjunction with the air-current and deliver such grain against the reticulated surface of the grinding-cylinder, all of which will be more fully hereinafter described. The sleeve upon which the rotating bottom portion is mounted is provided with a pulley C² for the purpose of rotating it, preferably in a direction opposite to the rotation of the outer cylinder.

By rotating the grinding-cylinder and bottom portion relatively to each other in opposite directions an outward current of air is produced by the rotation of the bottom C'

and the ribs c' thereon, and this outward current of air is opposed adjacent to the grinding-cylinder by the air-current produced by the rotation of the cylinder, causing a reduced force of propulsion, by which the kernels or berries will be prevented from striking too violently against the grinding or decorticating surface. The kernels or berries are carried, fed, or impelled to the outer periphery of the bottom by the action of centrifugal force in connection with a current of air, and the tumbling action which takes place in the outward travel and by the striking against the grinding-cylinder acts to remove the shell.

In order, however, to facilitate the removal of the shell and hasten the process by positive mechanical means, I provide a sleeve E and preferably secure it to the lower sleeve C, so as to rotate with it at the same speed and in the same direction. This second sleeve is preferably provided with one or more radial arms made in two sections or parts E' E^3 , and adjustably mounted thereon, at the outer ends, are curved grinding-shoes E^2 , which are perforated and lined with a covering of reticulated material e , the perforations providing for the passage of air through the grinding-shoes, thereby preventing the adhesion of the husks or shells to the grinding-surfaces.

These grinding-shoes are arranged substantially concentric with the grinding-cylinder, so as to provide in connection with the oppositely-moving cylinder an annular channel e' , in which the material may be acted on. In Figs. 2 and 4 of the drawings I have shown the two sections or parts of the radial arms as adjustably secured together by means of bolts and nuts e^2 for the purpose of moving the shoes inwardly or outwardly to change the size of the channel e' , and thereby change the machine from a shelling to a grinding machine, or vice versa, or to change the machine so as to adapt it for the shelling or grinding of different-sized grain or berries.

In order to provide means for feeding the grain or similar material into the grinding or separating cylinder, I make the upper part of the rotating shaft hollow, or, in other words, provide it with an axial channel G. The upper end of the shaft is provided with a supply-pipe g , connected with the shaft by means of a stuffing-box g' , which permits the rotation of the shaft. This supply-pipe is provided with a hopper g^2 , of any suitable and well-known form of construction and arrangement that will permit the grain or similar material during the rotation of the parts to be directly and automatically fed into the machine in a uniform manner.

During the operation of shelling the outer cylinder is preferably run in a direction opposite to the movements of the bottom portion and grinding-shoes. The ribs c' of the bottom portion act in a measure as a fan to draw in air through the perforated bottom portion and expel it through the grinding-cylinder. The material is fed into the machine

as above described and immediately strikes the bottom portion to be impelled by centrifugal force and current of air outwardly against the grinding shelling-cylinder and into the channel between it and the grinding-shoes, where during the opposite rotation of the parts it is stripped of its covering or shell, and such covering or shell is pulverized or finely broken and by the suction of the air and centrifugal force carried out through the reticulated lining and perforations in the cylinder to fall in a waste-chamber H, formed by the casing h and its bottom portion h' and cover h^2 , while the shelled or decorticated berry falls back on the bottom portion C' . The bottom portion h' of the waste-chamber is preferably inclined downward from its periphery, so as to remove the husk or shell out of contact with the grinding-cylinder and air-currents and permit such husks or shells to be withdrawn from the chamber H through the discharge-opening h^3 , which opening can be closed by a sliding door or otherwise. The shelled grain or berries falling back on the bottom C' rest thereon, and in order to discharge or withdraw such grain or berries, preferably when the machine is at rest, a longitudinally-movable sleeve or annular gate D is provided, which surrounds the rotatable shaft and is arranged between it and the actuating-sleeve. This annular or cylindrical gate D is arranged to open and close an annular discharge-channel from the bottom C' , which channel is formed by the space between the hub of the bottom C' and the shaft B left by the downward withdrawal of the annular or cylindrical gate below the lower end of the sleeve E, which discharge-channel is closed when the gate is at the limit of its upward movement and in contact with the end of the sleeve E. This gate is moved downwardly by means of the lever K, which engages with a split ring k on the sleeve until the sleeve passes out of engagement with and below the actuating-sleeve C. When this cylindrical gate is at its lower limit of motion, the annular discharge-channel formed by the space between the shaft B and the sleeve C and continued through the hub of the bottom C' is opened and communicates with the openings c^2 around the central portion or hub of the bottom C' between the ribs c' , (particularly shown in Fig. 6,) so that the cleaned kernels may fall down through this channel between the shaft B and sleeve C and pass out at the opening between the ends of the sleeves C and D into a hopper L and pass out through a spout l into any desired receptacle. When the grain is withdrawn from the machine, the cylindrical gate is moved to its upper limit of motion, as is shown in the drawings, and the machine is again in condition for operation.

It is oftentimes desirable to clean the interior mechanism, and in order to accomplish this result a manhole B^4 is provided (see Fig. 3) having a reticulated door B^5 and so arranged that the manhole may be brought into

line with an opening h^6 in the casing, through which the hand may be inserted for cleaning purposes.

As hereinbefore stated, the actions of the machine are had by centrifugal force, assisted by the air-currents, which impel the grain or berries out and against the reticulated lining of the grinding-cylinder, so as to contact with the cylinder and be stripped of the husks or shells by the reverse movements of the rotating grinding-shoes, and in the operation the ribs c' of the reticulated bottom portion C' act as a fan to form an air-current and impel the husks and shells forward and out through the perforated cylinder. This outward circulating current of air meeting the reverse current of air from the grinding-cylinder results in the production of a cushion effect on the grinding-cylinder, which acts in a measure to soften the action of the centrifugal force from what it would be if there were no provision of this nature. The air-current, therefore, may be considered as a valuable element in the process of shelling the articles. There are times, however, when the produced air-current might not be sufficient, and to increase this air-current and at the same time assist in the feeding in of the material I provide a fan or blower M , which has a pipe m connected with the waste-chamber H of the casing and with the inlet-opening of the fan, while a pipe m' connects with the supply-pipe of the machine and the exit-opening of the fan, thereby creating an additional current of air to assist in the operations of the machine.

An inspection of Fig. 4 of the drawings will show that the grinding-shoes are made curved and that a portion of the same is arranged substantially concentric with the rotatable cylinder, and another portion has a sharper curve to assist in forming a flaring opening or mouth at the entrance of the grinding-channel, so as to give an initial squeeze and break the husk or cover before entering the channel, thereby preventing possible injurious crushing of the grain or berries, which might occur if the husks or covers were not first cracked or partially broken. It is desirable at times to shift this grinding-shoe in a manner eccentric, and in order to accomplish this result I pivot the grinding-shoe by means of the screw e^4 to its adjustable radial arm, so that its position may be changed to suit different circumstances and conditions.

In operation when the machine is set for shelling, as above described, the grinding shoe or shoes should bear such a relation to the reticulated surface of the rotatable cylinder as to permit a layer of grain to pass through the channel and be squeezed sufficiently to strip the same. The mechanisms are then operated and the grain fed in through the axial channel in the rotatable shaft. The rotations of the machine generate centrifugal force and impel the grains or berries upwardly against the reticulated cylinder and

into the channel formed between the same and the rotating grinding-shoes, which act to strip them of their husks or shells, which are pulverized or finely broken and forced out by the current of air and centrifugal force into the waste-chamber H , from which they may be withdrawn in any manner desired through the discharge-opening h^3 . When the machine has been operated sufficiently long to accumulate a large quantity of shelled berries or kernels, the annular or cylindrical gate D is opened and the berries allowed to pass out into any suitable receptacle. The operations may be repeated and continued as long as seems desirable or necessary.

I have hereinbefore described the operation of shelling. The operation of grinding can be performed in the same machine by setting the grinding-arms close to the reticulated cylinder, so that as they operate in a relatively reverse rotation to each other they form an annular grinding-channel, in which the berries or kernels are caught and crushed into a fine condition and forced out by the current of air and centrifugal force into the waste-chamber H , which then becomes a receiving-chamber for the ground material. In this way the operation can be kept up continuously without cessation or stoppage until the entire amount of grain or spices has been pulverized or ground as fine as desired.

While I have described my invention with more or less minuteness as regards details of construction and arrangement and as being embodied in certain precise forms, I do not desire to be limited thereto unduly or any more than is pointed out in the claims. On the contrary, I contemplate all proper changes in form, construction, and arrangement, the omission of immaterial elements, and the substitution of equivalents, as circumstances may suggest or necessity render expedient.

I claim—

1. In a mechanism of the class described, the combination of a perforated horizontal bottom provided with a peripheral flange or wall and having a rotation given thereto producing a centrifugal blast for the momentum of the blast to carry outward the material deposited on the bottom, and a perforated vertical cylinder in line with the peripheral flange or wall of the bottom and provided with an inner reticulated surface, and having an opposite rotation given thereto to the rotation of the bottom producing an opposing current to the centrifugal blast to resist the impact of the material against the reticulated surface of the cylinder, substantially as described.

2. In a mechanism of the class described, the combination of a perforated horizontal bottom provided with a peripheral flange or wall and with radial ribs on its inner face and having a rotation given thereto producing a centrifugal blast for the momentum of the blast to carry outward the material de-

posited on the bottom, and a perforated vertical cylinder in line with the peripheral flange or wall of the bottom and provided with an inner reticulated surface and having
 5 an opposite rotation given thereto to the rotation of the bottom producing an opposing current to the centrifugal blast to resist the impact of the material against the reticulated surface of the cylinder, substantially as described.
 10

3. In a mechanism of the class described, the combination of a perforated horizontal bottom provided with radial ribs on its inner face and with a peripheral flange or wall and
 15 having on its inner face a reticulated surface, a perforated vertical cylinder in line with the peripheral flange or wall and provided with an inner reticulated surface, and a vertical perforated adjustable grinding-ring provided
 20 with an outer reticulated surface and forming in connection with the outer grinding-cylinder and its reticulated surface an annular channel into which the grain and spices are forced by the action of the horizontal bottom
 25 and caught and acted on, substantially as described.

4. In mechanisms of the class described, the combination of an outer rotatable perforated cylinder provided with an inner reticulated grinding-surface, one or more adjustable grinding-shoes arranged to rotate in a
 30 direction opposite to the perforated grinding-cylinder and provided with a reticulated covering forming in conjunction with the oppositely-moving cylinder an annular channel in
 35 which grain may be acted on, substantially as described.

5. In mechanisms of the class described, the combination of an outer perforated rotatable
 40 cylinder provided with a reticulated or meshed inner surface, an arm or arms provided with a curved grinding-shoe at their outer ends perforated and provided with a reticulated covering and arranged to rotate and
 45 form in connection with the grinding-cylinder an annular channel into which grain may be passed and acted on, and means for adjusting the grinding-shoes on the arms inwardly or outwardly to vary the size of the annular
 50 channel, substantially as described.

6. In a machine of the class described, the combination of an outer rotatable cylinder provided with an inner reticulated surface, a
 55 reticulated bottom portion arranged to rotate and provided with upwardly-projecting ribs radially arranged, and one or more grinding-shoes arranged to rotate in the same direction as the bottom portion and provided with a reticulated grinding-surface and forming in
 60 connection with the rotating cylinder an annular channel into which grain may be passed and acted on, substantially as described.

7. In a machine of the class described, the combination of an outer rotatable cylinder
 65 having a reticulated inner grinding-surface, a rotatable bottom portion inclined inwardly and downwardly and provided with several

radial upwardly-projecting reticulated ribs, one or more radial arms provided with curved reticulated grinding-shoes arranged to rotate
 70 in the same direction as the bottom portion and form in connection with the rotating reticulated cylinder an annular channel into which cereals may be passed for the purpose of being acted on, means for feeding the material into the machine, and means for withdrawing the shelled grain or cereals at or near
 75 the center of the machine, substantially as described.

8. In mechanisms of the class described, the combination of a rotatable reticulated
 80 cylinder, a reticulated bottom portion having reticulated upwardly-projecting ribs radially arranged to rotate in a direction opposite to the cylinder, one or more curved grinding-shoes
 85 arranged to rotate in the same direction as the bottom portion and provided with a reticulated grinding-surface forming in connection with the oppositely-moving cylinder an annular channel into which the material may be passed and acted upon, a rotatable shaft upon which the cylinder is mounted provided with an axial opening connected with the cylinder-chamber so that grain or cereals may be fed into the machine at the center portion
 95 and during the operation of the machine, substantially as described.

9. In a machine of the class described, the combination of an outer rotatable reticulated
 100 cylinder, a reticulated bottom portion having upwardly-projecting reticulated radial ribs and inclined downwardly and inwardly so as to provide openings near the central portion thereof, a sleeve upon which said bottom portion is mounted and rotated in a direction opposite to the movement of the cylinder, an arm or arms connected with the sleeve portion and provided with a grinding-shoe at the outer ends thereof arranged in the same plane with the cylinder and provided with a reticulated grinding surface or covering so as to
 110 form in connection with the moving cylinder an annular channel into which grain or cereals may be passed and acted upon, a cylindrical gate or sleeve interposed between the first-named sleeve and the rotatable shaft so as to open or close an annular discharge-channel which connects the central portion of the machine with the outside so as to provide for the withdrawal of cleaned berries or kernels, and means for operating the cylindrical gate or sleeve, substantially as described.
 115

10. In a machine of the class described, the combination of an outer rotatable perforated
 120 cylinder provided with an inner reticulated grinding-surface and a reticulated cover, a perforated bottom portion inclined inwardly and downwardly and having a reticulated surface, radial reticulated ribs on such bottom portion providing openings between the same at or near the central portion, a rotatable shaft secured to the rotating cylinder and provided with an axial opening having radial perforations connecting with the inte-
 125

rior of the machine and forming a supply-channel for the machine, a sleeve portion upon which the bottom portion is mounted and arranged to be rotated in a direction opposite to the movements of the rotating cylinder, a radial arm or arms secured to the rotating sleeve, curved perforated grinding-shoes provided with a reticulated grinding surface or covering arranged concentric with the rotating cylinder and adjustably secured to the radial arm or arms, and a cylindrical sleeve or gate arranged inside the rotating sleeve of the bottom portion so as to cover and uncover an annular channel communicating with the outside of the machine for the purpose of discharging the shelled cleaned grain at the center of the machine, substantially as described.

11. In a machine of the class described, the combination of a perforated rotatable grinding-cylinder provided with an inner lining and cover of reticulated material, a perforated bottom portion inclined inwardly and downwardly and provided with a reticulated covering, reticulated ribs arranged radially on such bottom portion, perforated reticulated curved grinding-shoes arranged to rotate with the bottom portion and form with the rotating cylinder an annular channel, means for adjusting the shoes inwardly and outwardly so that the size of the annular channel formed by the rotations of the cylinder and shoes may be regulated, means for feeding the grain or cereal into the machine at or near the central point, and a casing inclosing the rotating cylinder and forming a waste-chamber, substantially as described.

12. In a machine of the class described, the combination of a rotatable perforated cylinder provided with an inner reticulated lining and cover, a rotatable shaft upon which such cylinder is mounted and provided with an axial supply-channel connected with the interior of the cylinder, a rotatable perforated bottom portion inclined downwardly and inwardly provided with a reticulated covering, reticulated upwardly-projecting ribs radially arranged on such bottom portion, a sleeve upon which such bottom portion is mounted and rotated in a direction opposite to the rotations of the cylinder, one or more radial arms on such sleeve, perforated grinding-shoes adjustably secured to such arms and provided with reticulated grinding-surfaces arranged in connection with the moving cylinder to form an annular channel into which cereals may be passed and acted on, a casing inclosing the rotating cylinder and provided with a bottom portion inclining downwardly and outwardly and forming a waste-chamber from which material may be withdrawn, a fan having its inlet-opening connected with the waste-chamber and its exit-opening connected with the supply-channel in the rotatable shaft, and means for introducing grain into the supply-channel of the rotatable shaft, substantially as described.

13. In a machine of the class described, the combination of an outer perforated rotatable grinding-cylinder provided with an inner reticulated lining and cover portion, a rotatable shaft upon which such cylinder is mounted having an axial supply-channel connected with the cylindrical chamber and forming a supply-channel for the introduction of a cereal or grain, a perforated bottom portion inclined inwardly and downwardly and provided with a reticulated covering, upwardly-projecting ribs radially arranged on such bottom portion and forming openings at or near the central portion thereof, a rotatable sleeve surrounding the rotating shaft upon which the bottom portion is mounted and rotated, a radial arm or arms connected with such sleeve inside of the rotating cylinder, a curved perforated grinding-shoe adjustably attached to each of such arms and provided with a reticulated grinding-surface and arranged to form in connection with the moving grinding-cylinder a channel into which grain may be passed and acted on, a cylindrical sleeve or gate longitudinally movably mounted on the rotatable shaft between it and the rotating actuating-sleeve arranged by its movements to open or close an annular discharge-channel from the bottom portion of the machine to the outside, an operating-lever for such cylindrical gate, and a hopper portion arranged under such cylindrical gate to receive the discharged grain and deliver it to a receptacle as may be desired, substantially as described.

14. In a machine of the class described, the combination of an outer perforated rotatable grinding-cylinder provided with an inner lining and cover of reticulated material, a rotatable shaft upon which such cylinder is mounted provided with an axial supply-channel connecting with the chamber inside the cylinder, a perforated rotatable bottom portion inclined inwardly and downwardly and provided with a covering of reticulated material, upwardly-projecting reticulated rib portions substantially radially arranged on such bottom portion and providing discharge-openings at or near the center portion, a sleeve upon which such bottom portion is mounted and rotated in a direction opposite to the movements of the rotatable cylinder, a radial arm or arms secured to so as to rotate with the sleeve, perforated grinding-shoes adjustably secured to the radial arms provided with a reticulated grinding-surface and arranged by their movements and the opposite movements of the grinding-cylinder to form a channel into which material may be passed and acted on, a cylindrical sleeve or gate interposed between the rotatable sleeve and shaft and longitudinally movably mounted between such elements and so arranged by its movements to open or close a discharge-channel between the bottom of the grinding-chamber and the outside, a lever for raising and lowering such cylindrical gate or sleeve, a hopper or similar element to receive the

discharged grain, a case inclosing the rotating cylinder and provided with a bottom portion inclined downwardly and outwardly to form a waste-chamber, a fan having its inlet-
5 opening connected with the waste-chamber, a pipe connecting the outlet of the fan with the supply-channel of the rotatable shaft,

and means for introducing into such pipe a supply of cereals or spices, substantially as described.

ALEXANDER J. RUDOLPH.

Witnesses:

THOMAS F. SHERIDAN,
THOMAS B. MCGREGOR.