

(No Model.)

F. W. MIX,
LOCK.

No. 524,642.

Patented Aug. 14, 1894.

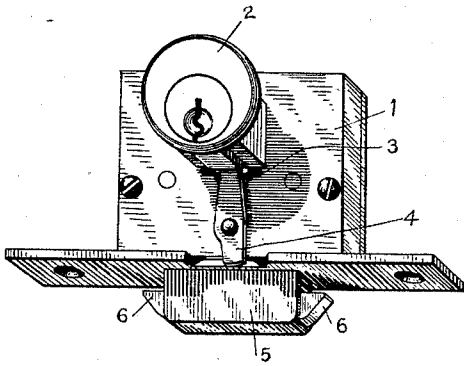

FIG. 1.

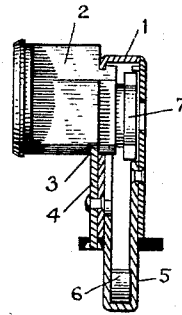

FIG. 2.

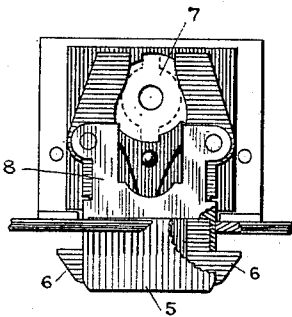

FIG. 3.

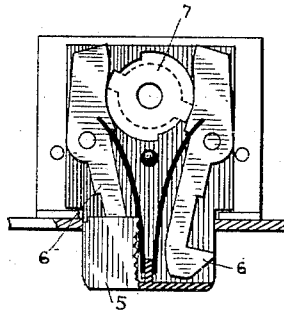

FIG. 4.

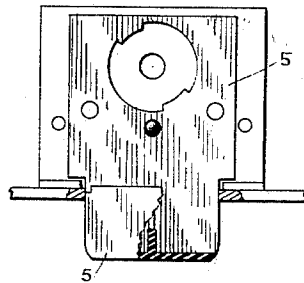

FIG. 5.

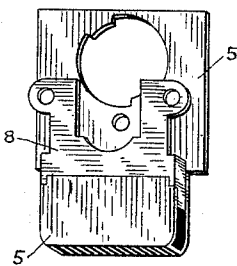

FIG. 6.

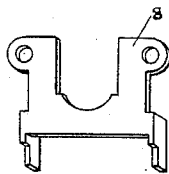

FIG. 7.

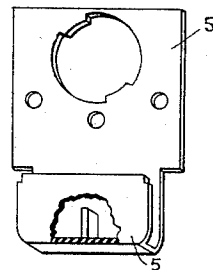

FIG. 8.

WITNESSES

Chas. A. Berry.
Geo. C. Clum.

INVENTOR

Frank W. Mix.
By Knight Bros
Attys.

UNITED STATES PATENT OFFICE.

FRANK W. MIX, OF STAMFORD, CONNECTICUT, ASSIGNOR TO THE YALE & TOWNE MANUFACTURING COMPANY, OF SAME PLACE.

LOCK.

SPECIFICATION forming part of Letters Patent No. 524,642, dated August 14, 1894.

Application filed January 3, 1894. Serial No. 495,542. (No model.)

To all whom it may concern:

Be it known that I, FRANK W. MIX, a citizen of the United States, residing at Stamford, county of Fairfield, State of Connecticut, have invented certain new and useful Improvements in Locks, of which the following is a specification.

My invention relates to improvements in self-locking cabinet locks, that is, locks designed for desks and other furniture, and my objects are to add to the security of such locks, while at the same time the locks shall be simple in construction and strong.

There have been for some time largely in use self-locking cabinet locks which are locked by spring actuated hooks, these hooks usually also being the tumblers upon which the key acts; such, for example, are the locks shown in patent of E. L. Gaylord, dated January 8, 1873, No. 135,270, and also in prior patent of mine, dated March 18, 1884, No. 295,270. A desirable feature also in this class of locks is a piece which is variously styled a steady pin, or a guide, or hollow bolt, the object of this piece variously styled being to protect the hooks in the ordinary use of the locks against damage, and to prevent the desk or other article of furniture being opened by a sidewise motion of the lid, and also to prevent access to the hooks by means of a picking tool.

In my present invention I accomplish all the results obtained in the earlier locks, with certain improvements due to an entirely new combination of parts, by the use of different locking mechanism, and by a novel and additional protection for the hooks.

Heretofore all self-locking locks of the class above referred to have had the locking mechanism attached to the case of the lock proper. But I make a new combination by adapting to locks of this class a tumbler case or cylinder which contains the tumbler mechanism upon which the key acts and actuates the hook or bolt mechanism by some connection with it through the rear of said tumbler case.

In my drawings I have shown the tumbler mechanism which is widely known as the Yale mechanism, but the particular form of mechanism is not essential to my invention. The use of this new combination results in a lock which is of greater security against picking,

and has the great convenience to the user of requiring only a small key, without reference to the thickness of the wood, and also permits a very simple and strong connection between the key mechanism and the bolt mechanism. I also provide greatly increased security against manipulation of the hooks or bolts which, however, I will describe later in connection with the drawings.

My methods of accomplishing the results above referred to are illustrated in the accompanying drawings, in which—

Figure 1 is a front elevation of the lock with the tumbler case in place. Fig. 2 is a section of the lock showing the tumbler case in place and illustrating the method by which said tumbler case is fastened to the lock case. Fig. 3 is a front elevation of the lock with the cap and tumbler case removed, and with the hollow bolt or housing broken away to show my improved additional guard for protecting the hooks from access. Fig. 4 shows the same view as Fig. 3, with the guard also removed. Fig. 5 shows the same view as Fig. 4 with the hooks removed. Fig. 6 shows the hollow bolt or housing for the hooks, with the hook guard in position. Fig. 7 shows a detached view of the guard by itself. Fig. 8 is a detached view of the hollow bolt or housing to illustrate the method of fitting the guard to it.

1 is the cap of the lock; 2 the lock cylinder or tumbler case; 3 the slot into which the catch or dog 4 slides to hold the tumbler case in place when it is hooked onto the cap of the lock; 5 the hollow bolt or housing for the hooks; 6, 6 are the hooks; 7 the cam at the rear of the plug of the tumbler case, said cam actuating the hooks 6, 6 for unlocking; and 8 is the supplemental independent guard which is attached in any convenient manner to the lock case, and which encircles the edges of the spring bolts or hooks, so that access to their said edges is prevented. This guard may be of any convenient form, and attached in any convenient manner.

In the drawings I have shown a guard formed of a plate or cap having perforations which fit over the pivot posts of the hooks, and flanges which project at right angles from the plate and guard the edges of the hooks.

In practice the lock would be put in place

by first removing the tumbler case, then inserting the lock into its mortise; hooking the tumbler case into the lock cap and pushing the dog into position to hold the tumbler case.

5 The style of the dog is not material. An advantage of this construction is that if for any reason the combination of the lock should be required to be changed, this can readily be done either by taking off the tumbler case
10 and having the combination reset, or by substituting a new tumbler case which can be had from the manufacturer without the necessity of buying an entire new lock.

Having thus described my invention, the
15 following is what I claim as new therein and desire to secure by Letters Patent:

1. In combination with a self-locking lock, an independent supplemental guard which fits over and prevents access to the edges of
20 the locking hooks or bolts when the lock is in locked position, substantially as described.

2. In a self-locking lock, the combination of the lock case pivoted hooks or bolts supported in said lock case, and an independent
25 supplemental guard fitting over the hooks or

bolts and provided with flanges which project over and guard the edges of the hooks or bolts, substantially as described.

3. In a self-locking lock, a stationary hollow bolt, partially inclosed spring pressed hooks
30 projecting from either side thereof, with guards attached to said hollow bolt for protecting the edges of said hooks from access, substantially as described.

4. In a cabinet lock, the combination of the
35 stationary hollow bolt 5, the hooks or bolts 6, 6, the removable tumbler case 2, the dog 4 for securing the tumbler case in place, and a key plug in the tumbler case provided with the cam 7 which is adapted to actuate the
40 hooks or bolts, substantially as described.

5. A cabinet lock provided with a stationary hollow bolt 5, the hooks 6 6, tumbler case 2, dog 4, cam 7, and guard 8, substantially as described.

FRANK W. MIX.

Witnesses:

SCHUYLER MERRITT,
GEO. E. WHITE.