

T. F. HAMILTON.

Stove-Drums.

No. 134,054.

Patented Dec. 17, 1872.

Fig. 1.

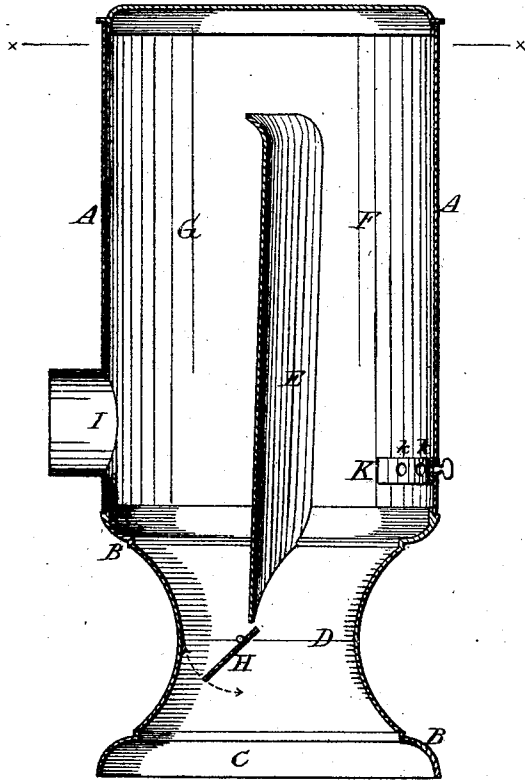
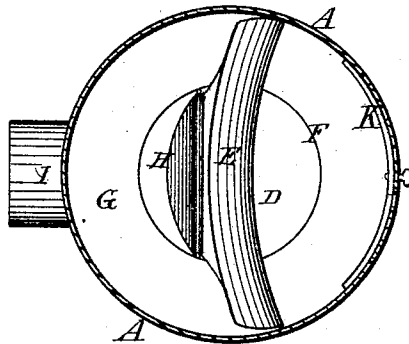

Fig. 2.



Witnesses,
A. Poole
John R. Young

Inventor,
Thos. F. Hamilton, by
Purdell and Co., his Attys

UNITED STATES PATENT OFFICE.

THOMAS FOSTER HAMILTON, OF GENESEO, ILLINOIS.

IMPROVEMENT IN STOVE-DRUMS.

Specification forming part of Letters Patent No. 134,054, dated December 17, 1872.

To all whom it may concern:

Be it known that I, THOMAS F. HAMILTON, of Geneseo, in the county of Henry and in the State of Illinois, have invented certain new and useful Improvements in Stoves; and do hereby declare that the following is a full, clear, and exact description thereof, reference being had to the accompanying drawing making a part of this specification, in which—

Figure 1 is a vertical central section of my improved device upon a line extending from front to rear, and Fig. 2 is a horizontal section of the same upon line *xx* of Fig. 1.

Letters of like name and kind refer to like parts in each of the figures.

The design of my invention is to increase the heating capacity of the drums of ordinary cannon-stoves; and to this end it consists, principally, in the arrangement of the flue-plate and damper within the drum, substantially as and for the purpose hereinafter specified. It consists, further, in the arrangement of certain air-passages with relation to the flue-plate and to the front flue formed thereby, substantially as and for the purpose hereinafter shown. It consists, finally, in the peculiar construction of the flue-plate and its combination with the drum, substantially as and for the purpose set forth.

In the annexed drawing, A represents a sheet-metal drum, of usual construction and shape exteriorly, which is secured to or upon the upper end of an ordinary cannon-stove, B, which latter, between said drum and the combustion-chamber C, is contracted so as to form a passage, D, having about one-half the horizontal area of said drum. Extending transversely between the walls of the drum A and vertically from the contracted passage D to a point near the upper end of said drum is a flue-plate E, which preferably has a slight rearward curve transversely, and at its upper end is turned rearward, as shown, the effect of said plate being to divide the interior of said drum into two compartments or flues, F and G, respectively. A damper, H, placed at the lower end of the flue-plate E, and extending between the same and the contiguous rear wall of the stove, corresponds to and closes the lower end of the flue, and compels the heated escaping products of combustion to pass upward through the front flue or compartment F, over the flue-plate E, into and downward through said flue G, before they can reach the exit-flue I, which is placed at the rear side and near the lower end of the

drum, said gaseous products of combustion having during their passage from the stove to the exit-flue parted with a large proportion of their heat. In order that the combustible portion of the escaping gases may be consumed and their heat utilized, a series of small openings, *k*, are provided in and through the front wall and lower end of the drum, through which inward-flowing currents of air enter the flue F, and mingling with said heated gases as they leave the combustion-chamber furnish the requisite amount of oxygen to cause them to be consumed. A damper, K, enables the effective size of said openings *k* to be regulated at will.

By this construction it will be seen that the heated gases are first caused to impinge upon or against the front side of the drum where most heat is required, and afterward to pass to the upper end, and thence down the rear side of said drum before escaping into the chimney instead, as heretofore, of passing directly from the stove into said flue, by which means the heating capacity of the stove is not only materially increased, but the largest proportion of the heat thrown to the front. In addition to the above advantages, by mingling the requisite proportion of air with the escaping gases before they have parted with their high temperature, said gases are consumed and a large proportion of the heating properties of the fuel utilized instead, as heretofore, of being wasted.

Having thus fully set forth the nature and merits of my invention, what I claim as new is—

1. The relative arrangement of the flue-plate E, flue F, and air-passages *k* within the drum A, substantially as and for the purpose shown.

2. The flue-plate E, made concave at its front side and provided at its upper end with a rearward-curving flange, in combination with the drum A, substantially as and for the purpose set forth.

3. The said flue-plate E and damper H, when constructed as shown, and relatively arranged within the drum A and stove B, substantially as and for the purpose specified.

In testimony that I claim the foregoing I have hereunto set my hand this 6th day of November, 1872.

THOMAS FOSTER HAMILTON.

Witnesses:

THOMAS R. HASKER,
J. M. HOSFORD.