

(12) STANDARD PATENT
(19) AUSTRALIAN PATENT OFFICE

(11) Application No. **AU 2001237298 B2**

(54) Title
Panel element

(51)⁷ International Patent Classification(s)
E04F 015/04

(21) Application No: **2001237298** (22) Date of Filing: **2001.01.12**

(87) WIPO No: **WO01/51732**

(30) Priority Data

(31) Number	(32) Date	(33) Country
100 01 076.8	2000.01.13	DE

(43) Publication Date: **2001.07.24**

(43) Publication Journal Date: **2001.10.04**

(44) Accepted Journal Date: **2004.04.08**

(71) Applicant(s)
Hulsta-Werke Huls GmbH & Co. KG

(72) Inventor(s)
Mensing, Ansgar; Schwitte, Richard

(74) Agent / Attorney
Cullen & Co, 239 George Street, Brisbane, QLD, 4000

(56) Related Art
EP 0085196
FR 2278876
AU 64930/99

(12) NACH DEM VERTRAG ÜBER DIE INTERNATIONALE ZUSAMMENARBEIT AUF DEM GEBIET DES
PATENTWESENS (PCT) VERÖFFENTLICHTE INTERNATIONALE ANMELDUNG

(19) Weltorganisation für geistiges Eigentum
Internationales Büro



(43) Internationales Veröffentlichungsdatum
19. Juli 2001 (19.07.2001)

PCT

(10) Internationale Veröffentlichungsnummer
WO 01/51732 A1

- (51) Internationale Patentklassifikation⁷: E04F 15/04 (71) Anmelder (für alle Bestimmungsstaaten mit Ausnahme von US): HÜLSTA-WERKE HÜLS GMBH & CO. KG [DE/DE]; Gerhart-Hauptmann-Str. 43-49, 48703 Stadtlohn (DE).
- (21) Internationales Aktenzeichen: PCT/EP01/00359 (72) Erfinder; und (75) Erfinder/Anmelder (nur für US): SCHWITTE, Richard [DE/DE]; Ebbingshof 64, 48712 Gescher (DE). MENSING, Ansgar [DE/DE]; Schöppinger Str. 28, 48619 Heek-Nienborg (DE).
- (22) Internationales Anmeldedatum: 12. Januar 2001 (12.01.2001) (74) Anwälte: FÜCHSLE, Klaus usw.; Hoffmann Eitle, Arabellastrasse 4, 81925 München (DE).
- (25) Einreichungssprache: Deutsch
- (26) Veröffentlichungssprache: Deutsch
- (30) Angaben zur Priorität: 100 01 076.8 13. Januar 2000 (13.01.2000) DE

[Fortsetzung auf der nächsten Seite]

(54) Title: PANEL ELEMENT

(54) Bezeichnung: PANEELEMENT

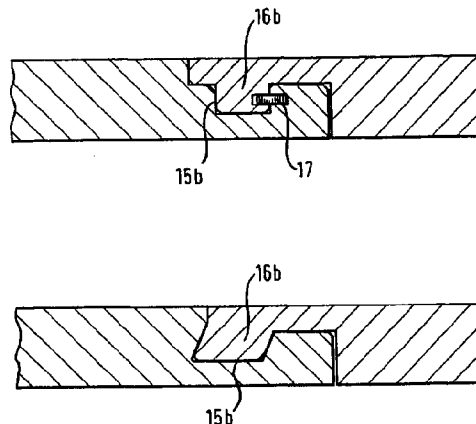

(57) Abstract: The invention relates to a panel element (1) for forming a floor covering, consisting of several identical, interconnectable panel elements (1) and having the following features: - two first sides of each panel element, called the "longitudinal sides" (1), these sides having a groove (2) and a tongue (3); the tongue (3) of a panel element which is positioned at an angle with an installation level of a first, identical panel element (1) can be introduced into the groove (2) of the first panel element (1); the tongue (3) interacts with the groove (2) of the adjacent, identical panel element (1) in such a way that two interconnected panel elements (1) are protected against separating forces which are exerted along both of the axes extending perpendicularly to the longitudinal side of the panel elements (1); two second sides of the panel element (1), called the end sides, are provided with fixing means and a groove (15b) and tongue (16b), these forming an end-side connection between two adjacent panel elements (1); the end-side grooves (15b) and tongues (16b) can be interconnected by means of the panel element (1) being lowered onto an identical panel element (1) that has already been installed, essentially crosswise to the installation level, so that the panel element (1) is protected from lifting forces, i.e. forces which are exerted considerably perpendicularly to the installation level.

(57) Zusammenfassung: Ein Paneelement (1) zur Ausbildung eines Fußbodenbelags aus mehreren gleichartigen, miteinander verbindbaren Paneelementen (1) weist folgende Merkmale auf: zwei erste, als Längsseiten bezeichnete Seiten jedes Paneelements (1) weisen einerseits eine Nut (2) und andererseits eine Feder (3) auf, die Feder (3) eines schräg zur Verlege-Ebene eines ersten, gleichartigen

[Fortsetzung auf der nächsten Seite]

WO 01/51732 A1



- (81) **Bestimmungsstaaten (national):** AE, AG, AL, AM, AT, AU, AZ, BA, BB, BG, BR, BY, BZ, CA, CH, CN, CR, CU, CZ, DE, DK, DM, DZ, EE, ES, FI, GB, GD, GE, GH, GM, HR, HU, ID, IL, IN, IS, JP, KE, KG, KP, KR, KZ, LC, LK, LR, LS, LT, LU, LV, MA, MD, MG, MK, MN, MW, MX, MZ, NO, NZ, PL, PT, RO, RU, SD, SE, SG, SI, SK, SL, TJ, TM, TR, TT, TZ, UA, UG, US, UZ, VN, YU, ZA, ZW, ES, FI, FR, GB, GR, IE, IT, LU, MC, NL, PT, SE, TR), OAPI-Patent (BF, BJ, CF, CG, CI, CM, GA, GN, GW, ML, MR, NE, SN, TD, TG).
- Veröffentlicht:**
— mit internationalem Recherchenbericht
— mit geänderten Ansprüchen
- (84) **Bestimmungsstaaten (regional):** ARIPO-Patent (GH, GM, KE, LS, MW, MZ, SD, SL, SZ, TZ, UG, ZW), eurasisches Patent (AM, AZ, BY, KG, KZ, MD, RU, TJ, TM), europäisches Patent (AT, BE, CH, CY, DE, DK, Zur Erklärung der Zweibuchstaben-Codes, und der anderen Abkürzungen wird auf die Erklärungen ("Guidance Notes on Codes and Abbreviations") am Anfang jeder regulären Ausgabe der PCT-Gazette verwiesen.

Panelemente (1) angesetzten Panelemente (1) ist in die Nut (2) des ersten Panelemente (1) einführbar, die Feder (3) wirkt mit der Nut (2) des benachbarten, gleichartigen Panelemente (1) derart zusammen, dass zwei miteinander verbundene Panelemente (1) gegen Trennkräfte gesichert sind, welche in beiden senkrecht zur Längsseite der Panelemente (1) verlaufenden Achsen wirken, zwei zweite, als Stirnseiten bezeichnete Seiten des Panelemente (1) sind mit Haltemitteln wie einerseits mit einer Nut (15b) und andererseits mit einer Feder (16b) versehen, die einen stirnseitigen Verbund zweier benachbarter Panelemente (1) bilden, die stirnseitigen Nuten (15b) und Federn (16b) sind mittels einer im wesentlichen quer zur Verlege-Ebene erfolgenden Absenkbewegung des Panelemente (1) auf ein bereits verlegtes, gleichartiges Panelement (1) miteinander verbindbar, so dass das Panelement (1) gegen abhebende, also weitgehend senkrecht zur Verlege-Ebene ausgerichtete Kräfte gesichert ist.

Panel Element

Field of the Invention

The invention relates to panel elements as set forth in the preamble of claim 1.

Panel elements for forming floor coverings are usually rectangular and elongated, although they may also feature other contours in being configured square, for example. Accordingly, in keeping with the usual rectangular configuration terms such as "side", "end" or the like are employed in the following without the invention being restricted to elongated panel elements. These terms serve in addition merely to distinguish first and second edges of the panel element each arranged parallel to the other in pairs and at an angle relative to the edges designated otherwise so that the geometry of the panel element provided for the "side" may also be provided at the other, for example, "end".

Prior Art

Known from GB 2,256,023 A is a generic panel element. It is provided for in the floor covering formed of several such panel elements that the individual panel elements feature a certain mobility relative to each other. This enables, especially when the panel elements are made of wood and the wood „works“ due to exposure to the weather or due to the influence of moisture, any opening up of joints between adjoining panel elements to be avoided since the clearance possible between adjoining panel elements as provided is designed to accommodate such movements of the natural material wood.

In some applications and depending on the furnishing style it may however be desirable to restrict the mobility of adjoining floor panel elements in preventing dirt from gaining access to the gaps as may materialize between adjoining panel elements. This is why it is known to fabricate non-generic floor coverings such that the tongue and groove geometries provided therein do not already prevent parting of adjoining floor panel elements so that these elements can be first simply jointed, namely married and not fixedly connected until glued and safeguarded against the cited parting forces whilst, on the one hand, being regularly sealed by the aforementioned glueing procedure so that at the joints of two adjoining panel elements neither moisture nor dirt is able to gain access.

Known from EP 0 085 196 A1 is a non-generic mat for forming a floor covering in which the complete edge is provided with coupling elements each complementary to the other. The coupling elements are configured at two edges as a groove open upwards and at the two other edges as a key extending downwards in thus enabling a mat to be joined to further mats of the same kind by it being urged at two edges simultaneously with its key facing downwards into the upwards open groove of mats already laid.

It is known in the field of the generic panel elements from WO 96/27719 to configure a groove from two adjoining edges of an elongated panel element, i.e. a side and an end, and to provide the lower cheek of the groove as a protruding element including a channel for receiving a complementary interlocking element at the opposite side in each case. The complementary interlocking element is configured to a certain extent at the underside of a tongue for inserting into the groove. As cited in this document these interlocking contours are configured the same on all four edges, it further being stated that laying is done in rows. This means that the panel elements of one row to be laid juxtaposed first need to be married at their ends before then

being connected married by their sides to the sides of the panels already laid. Such a procedure is, however, relatively laborious and a nuisance since several panel elements interlocked by their ends need to be handled.

By contrast it is known from DE 200 01 788 U1 to configure interlocking contours provided at a tongue and groove joint of the sides such that a second panel is swiveled in place with an already laid first panel before then being down-swivelled so that the tongue accesses the groove. By a subsequent shifting movement made parallel to the side edge a tongue provided at the end and including an interlocking element configured thereon is introduced into the groove of an already laid laterally adjoining panel. For this purpose at least the lower cheek of the groove provided at the end is configured flexible so that the tongue of the newly laid panel together with its interlocking element enters into the groove and can be interlocked by means of a retaining channel configured on one cheek of the groove. There is, however, likewise room for improving this procedure in simplifying laying.

Known from FR 2 278 876 A are panel-type elements provided at all four edges with interlocking means by means of which a panel to be newly laid can be interlocked with already laid adjoining panels by an urging movement made substantially perpendicular to the panel surface. A similar arrangement can be seen from EP 0 085 196 A1.

In conclusion, WO 00/47841 A1 describes floor panels provided at all four edges with projections or receiving grooves so that a panel can be urged in the vertical direction by the lateral interlocking means into the interlocking means of already laid panels, formed complementary thereto.

Summary of the Invention

The invention is based on the objective of providing panel elements for forming a floor covering permitting simple glueless laying of the floor covering whilst achieving and reliably maintaining a snug clearance-free contact in joining adjoining panel elements.

The objective forming the basis of the invention is achieved by the panel elements having the features as set forth in claim 1.

In accordance therewith two first edges, termed sides, of the panel elements in accordance with the invention comprise, on the one hand a groove and on the other a tongue. In other words, the one side of a rectangular, more particularly elongated panel element is provided with a groove and the other opposite side a tongue. It is understood that the panel elements in accordance with the invention may be just as well configured square so that two first edges, which must not be necessarily longer than the two edges as detailed in the following, are provided with a tongue and groove. At these first edges grooves and tongues formed complementary thereto are configured such that a second panel is located for laying at an angle to a first panel already laid before being swiveled about the side downwards in a plane with the already laid panel element such that the tongue of the panel element to be laid is introduced into the groove of the already laid panel element.

In the final laid condition the tongue of the second panel element cooperates with the groove of the first panel element of the same type adjoining the second panel element in the final condition such that the two married panel elements are safeguarded against parting forces acting in the two axes oriented perpendicular to the side of the panel elements. In other words, the cooperation of the tongue and groove prevents any of the two panel elements from being lifted out of place relative to the other in a direction perpendicular to the laying plane, i.e. perpendicular to the face surface of the panel elements. For another thing, tongue and groove comprise interlocking contours as detailed in the following for preventing parting of the two parting of the two panel elements from each other in a direction perpendicular to the sides and parallel to the face surface.

In accordance with the invention retaining means are also provided at two edges termed ends of the panel element which form an end joint of two adjoining panel elements. These retaining means, just like the retaining means at the sides in accordance with the invention prevent the married panel elements from being lifted relative to each other or

parted from each other in a direction perpendicular to the ends and parallel to the laying plane. Any suitable means may be provided as such retaining means. More particularly, these must not be necessarily configured as an interlockable tongue and groove. Instead, in general a groove or a channel suitable undercut may be provided into which a protruding element, i.e. a tongue having protuberances corresponding to the undercut of the groove configured complementary thereto or a latching protuberance or hook, engages.

In a completely novel approach as compared to prior art the end retaining means can be married by means of a lowering movement made substantially transversely to the laying plane of a panel element to be laid in the direction of a similar panel element already laid. In other words, in a departure from known from prior art, end interlocking is now achieved in that a panel element to be laid is correctly arranged also as regards the end on laying and that a swivel movement in the laying plane not only causes the tongue at the side to engage the corresponding groove but also at the same time a lowering movement produced at the same time perpendicular to the laying plane likewise engages the retaining means, i.e. the tongue or the latching protuberance at the end. This interlocking feature is configured more particularly in accordance with the invention so that two panel elements to be married as described are now reliably safeguarded at the ends against parting forces acting perpendicular to the end and parallel to the laying plane as well as against lifting forces acting substantially perpendicular to the laying plane. The result is a particularly simple yet reliable laying of a floor covering comprising several panel elements in accordance with the invention. Now, namely a single swivel or turning movement suffices to interlock a panel element to be laid at both its side and its end. To this extent, the invention also relates to a laying method characterized by locating a panel element to be laid by its tongue at the

side at an angle to an already laid panel element and joining it thereto at both the side as well as, without any further shift in the direction of the side, at the end by a swivel-down movement.

In configuring the interlocking contours at the side, more particularly of the retaining channel and rib, a prominent profiling may be provided to achieve high retaining forces of the married panel elements. In a departure from the laying method as is often employed, in which a panel element is shift-located horizontally to the already laid panel element, it is now provided for in accordance with the invention that the panel elements when laying the floor covering are no longer shifted into each other horizontally, but guided into each other by means of a swivel movement. This now permits selecting a prominent profiling of retaining channel and rib which would not permit two panel elements to be shifted into each other horizontally. However, by making use of a less prominent profiling and flexible configuration of the edge portion it is still possible to make use of the usual purely horizontally shifting method in laying.

It is to be noted that the invention is not restricted to the way of marrying and interlocking the sides as described above. Instead, it is just as conceivable and as is cited as a novelty at this point that an interlocking contour can now be provided at all edges of a substantially rectangular floor panel as may be provided as a laminate having a HDF or MDF centerply or as a finished parquet having both a HDF or MDF centerply as well as centerply of wood. On being inserted into the interlocking contours of adjoining floor panels already laid, this interlocking contour latches in place in a direction substantially perpendicular to the face surface of the panels. In other words, the interlocking contour provided in accordance with the invention at the ends, which on laying by being guided into the interlocking contour complementary thereto engages in a

substantially horizontal direction, may also be provided at the sides. For example, an end and the adjoining side may be provided with one form of such a interlocking contour, and the two other edges may comprise the form complementary thereto. In the course of laying, such a panel element is positioned at both the side and the end to some extent to the interlocking contours of the already laid panel element before then being urged into the interlocking contours substantially perpendicular to the face surface to form a joint at these locations. It is to be noted in this context that all embodiments of the interlocking contours as described in the following relative to the ends are just as suitable and conceivable likewise for the sides. It is further again emphasized that the embodiment as described above can be used to advantage also without the swivable joint as otherwise described at the sides. In summary the „snap fastener“ solution as described in accordance with the invention for the end may be provided at all edges of the panel.

The panel element in accordance with the invention develops its advantages particularly also in the preferred embodiment involving, as is to be preferred, not a laminate having a HDF or MDF centerply, but a finished parquet which may feature a centerply of HDF, MDF, plastics, some other wood-based material or also popular pinewood fingers. It is especially as regards the popular centerply of pine fingers comprising a comparatively irregular and rough face surface including faults, rosin galls and the like that the panel element in accordance with the invention offers the advantage that two panel elements adjoining each other by their sides now do not need to be shifted relative to each other. If this were the case, finished parquet on which the interlocking contours in accordance with the invention are provided at the sides could only be shifted with difficulty and with the aid of tools parallel to the sides to also interlock the ends. Now, in accordance with the invention no shifting in this direction is needed. Instead, the ends

can now be engaged and latched during the same movement, namely the swivel-in movement ensuring interlocking at the sides, substantially without any horizontally shift.

Preferred further embodiments read from the sub-claims.

As regards the interlocking reliability, especially at the side, it is good practice to configure the tongue such that it comprises at its underside a rib running in the longitudinal direction of the tongue and that the groove corresponding features at its underside, i.e. at the lower cheek of the groove, a retaining channel for receiving the rib. Good results have been achieved therewith in rendering laying both simple and reliable.

It is preferably provided for that the groove opens upwards at its mouth in thus facilitating insertion of the tongue of a panel element located at an angle. This enables the rib provided on the underside of the tongue to protrude comparatively far downwards from the tongue in enabling high retaining forces to materialize after the floor covering has been laid. This reliably prevents parting of the two adjoining panel elements in the laying plane of the floor, in other words in preventing them from being pulled apart transversely to the longitudinal direction of the panel element. Furthermore, bevelling the upper cheek of the groove, instead of the underside of the tongue, offers the advantage that the tongue comes into contact with the groove at both the top and bottom in a portion located relatively deeply in the groove in thus assuring a particularly rugged joint since the dimension between the two points of contact and joint spaced the most away from each other in the joint is comparatively large.

It is preferably provided for that the geometry of the tongue and groove results in a total of four contact locations between the two panel elements so that in this way the result is relatively rugged in also counteracting

any parting forces acting transversely to the laying plane of the floor and which could otherwise cause, for example, the adjoining panel element to lift or tilt. A swivel movement acting opposite to the swivel movement about the side as needed for interlocking at this location could prompt or facilitate an unwanted release. The four contact locations counteract such an unwanted swivel movement of two joined panel elements and can produce a regular latching connection requiring a latching force to be first overcome to release the two joined panel elements. More particularly, two first contact locations are provided at the upper side and underside of the tongue. The third and fourth contact location are advantageously separate from each other such that at the third contact location, preferably between retaining rib and retaining channel, a contact is formed in a direction parallel to the laying plane, i.e. usually horizontally, more particularly at the sidewall of the retaining channel. At the fourth contact location preferably located at leading end of the lower cheek of the groove and at a location alongside the rib, contact is made at an angle to the direction of the third contact location, preferably substantially vertically so that the location of two joined panel elements is precisely defined in the vertical direction, more particularly perpendicular to the laying plane.

It is further preferred that the plane of the groove or tongue is displaced downwards so that above the groove or tongue a material thickness is provided at least equal to or even thicker than that below the groove or tongue. This enables the human or furniture forces exerted in day-by-day use of the floor covering to be better accommodated in reducing the load on the tongue and groove joint so that two adjoining panel elements are subjected to diminished parting forces.

Preferably provided above the tongue is an upper contact surface area extending up to the upper side of the panel

element and to advantage a glue receiving channel is provided should the panel elements need to be laid permanently married by being glued. This glue receiving channel may be provided in the form of a recess extending longitudinally to and above the tongue, below the upper edge of the panel element, since it is in the region of this upper edge that a contact surface area for contacting an adjoining panel element is provided.

It may further be of advantage to provide two contact surface areas between two adjoining panel elements which prevent any movement in both directions transversely to the longitudinal direction of the panel element, i.e. on the one hand the contact surface area between the two panel elements so that the two panel elements cannot be shifted closer to each other, on the other, a second contact surface area as the contact surface area between the retaining channel, on the one hand, and the rib, on the other, so that the adjoining panel elements are safeguarded against forces tending to pull them apart. In this way, it is now possible to install the panel elements not only with zero clearance but also free of any gap in thus achieving a hygienically satisfactory floor covering featuring a practically closed face surface.

Tongue and groove interlocking the sides is additionally facilitated when the underside of the tongue runs rising to the free end of the tongue in thus enabling a panel element to be laid to be located at an angle to an already laid panel element particularly simply by its tongue before then being swivelled into place.

During the swivel movement on laying a panel element a latching point need to be overcome, it being this latching point that, after laying, reliably maintains the location of the laid panel elements. To achieve a smooth latching characteristic in thus simplifying laying, it is good practice to configure this latching point between the rib,

on the one hand, and the retaining channel, on the other. In this arrangement the retaining channel in the region of this latching point is rounded with as large a radius as possible so that no sudden, but a gradual increase in the latching pressure to be overcome materializes.

It is provided for to advantage that the side groove of the panel element permits adjoining at the right-hand end of the end groove. In this context the terms „right-hand“ and „left-hand“ have been selected in a view from above and outside, i.e. not from the centerpoint of the panel element in viewing a panel element oriented ready for laying with its decorative face facing upwards. This groove arrangement is unusual in the normal procedure for laying panel elements and surprising since it is usually so that the side groove of a panel element adjoins the left-hand end of the end groove.

The usual systematic approach in laying floor coverings as implemented by professionals and as known from the instructions for laying commercially available floor panel element systems prescribes starting from a specific corner of the room. To reliably achieve a good joint of two adjoining panel elements a specific pressure force usually needs to be exerted, this usually involving use of a block, located on the groove edge of the panel element to be newly laid, and intended to receive and distribute the hammer blow so that the panel element to be newly laid is urged by its tongue into the groove of an already laid panel element.

It may happen, especially when the floor is laid by non-professionals, that the block fails to be applied square on the groove edge with the risk of the edge being subjected to excessive force when struck, resulting in the edge of the panel element being deformed and the face surface damaged. This may result in an unwanted gap at the deformed

location or a trip joint. Apart from this, this may endanger the wet seal of the floor.

The geometry as proposed in the present contributes towards an unusual systematic approach in laying the floor in which whilst keeping to the direction of laying as usual the block is now not located on the edge of a groove but on the edge of the tongue of the panel element. The forces need to be applied by the hammer blow to marry the two panel elements are not sufficient to cause deformation of the tongue as could obstruct proper joint of the two panel elements. Now, in any case, by applying the block to the tongue the face surface of the panel element does not suffer in thus reliably assuring the desired face surface quality of the floor covering.

For interlocking the ends preference is given to an embodiment in which the end groove and the end tongue each feature a preferably slotted recess, the recesses being oriented in the final laying condition to receive an extraneous tongue by means of which two panel elements adjoining each other at the ends are safeguarded in this case from lifting out of place.

As an alternative, good results have been obtained with one embodiment in which the end tongue is provided with at least one hook-shaped protuberance configured preferably on one or both sidewalls of the tongue. The hooks may be configured as latching hooks, they being configured bevelled in the insertion direction and featuring a protuberance oriented substantially parallel to the laying plane to prevent lifting out of place. As an alternative such protuberances may of course also be configured at the side flanks of the end groove.

In conclusion good results have also been obtained with an embodiment in which the tongue is provided, preferably at its end, with at least one bulge or bead which can be

received by suitable recessed portions at the edges at the bottom of the end groove. To create additionally flexibility for such an interlocking feature these recesses may be configured larger than the bulges of the tongue.

Brief Description of the Drawings

Example embodiments of the invention will now be detailed with reference to the drawings in which

Fig. 1 is a cross-section through the portion of the tongue and groove configuration of the sides of two married panel elements,

Figs. 2 and 3 are cross-sections showing the joint of the sides of the two panel elements as shown in Fig. 1 in various stages in laying,

Fig. 4 is a diagrammatic view in perspective of simple detail illustrating the upper face of a panel element,

Figs. 5 and 6 are cross-sections each showing an example aspect of an end tongue and groove configuration of a panel element, and

Figs. 7 to 13 are cross-sections each showing a further example aspect of end jointed panel elements.

Detailed Description of Preferred Embodiments of the Invention

Referring now to Fig. 1 there is illustrated two panel elements of the same type identified 1, the one panel element 1 comprising a groove 2 and the other panel element 1 a tongue 3 extending into the groove 2 of the adjoining panel element 1. The material thickness of the panel element 1 is slightly more below the groove 2 or above the tongue 3 than below the groove 2 or the tongue 3

respectively so that pressures exerted by human or furniture loads can be accommodated relatively well in loading the tongue and groove joint to a minimum.

The two panel elements 1 are safeguarded against being lifted out of place by the meshing effect of the groove 2, on the one hand, and of the tongue 3 on the other, they likewise being safeguarded against compression forces acting downwards in addition to the support of the panel element 1 by the sub-floor on which the two panel elements 1 are laid.

The panel elements 1 are safeguarded against parting forces acting transversely to the longitudinal direction of the panel elements 1 by a contact surface area 4. Located along this contact surface area 4 a rib 5 configured at the underside of the tongue 3 contacts the sidewall of a retaining channel 6.

The forces acting contrary to these parting forces tending to urge the two panel elements 1 together are accommodated by a contact surface area 7 at which the two panel elements 1 are in contact with each other and which extends downwards from the upper edge of the two panel elements 1.

In the laid condition as evident from Fig. 1 four contact locations 8a to 8d materialize. In this arrangement, contact location 8c is identical to contact surface area 4. Due to these four contact locations 8a to 8d the two panel elements 1 are located as regards parting or angling forces so that the two panel elements 1 can only be shifted in parallel relative to each other in their longitudinal direction without any additional retaining force needing to be overcome.

In Fig. 1 a glueless joint of the two panel elements 1 is illustrated. A recess 9 above the tongue 3 and below the upper contact surface area 7 may serve, however, as a

channel to receive excess glue should the two panel elements 1 need to be married permanently and gap-sealed with the aid of glue.

Referring now to Fig. 2 there is illustrated how the two panel elements 1 are laid, the left-hand panel element 1, of which the groove 2 is evident, being already laid. The second panel 1 is positioned by its tongue 3 at an angle to the side edge of the first panel 1 whereby the tongue 3 is inserted as far as possible into the groove 2. This is facilitated by the groove 2 comprising an upper edge 10 ramped in the direction of the mouth of the groove 2 in thus forming an insertion channel 11 as evident more particularly from Fig. 1.

Likewise the tongue 3 comprises an underside 12 ramped in the direction of the free end of the tongue 3 so that the right-hand panel element 1 can be inserted into the groove 2 as far as possible in its angled position as evident from Fig. 2. This insertion movement is defined, on the one hand, by the tongue 1 contacting the upper and lower defining edges of the groove 2 and, on the other, by the two panel elements 1 in contact with each other in the region of their upper contact surface area 7.

Referring now to Fig. 3 there is illustrated how the right-hand panel element 1 is angled less steeply than as shown in Fig. 2 so that it can be inserted further into the groove 3. In this arrangement the rib 5 comes up against a section 14 by its rounded lower edge, the section running between the retaining channel 6 and the side edge of the panel element 1. The transition from this section 14 to the retaining channel 6 features a relatively large radius: in the example aspect shown the radius of this rounding corresponds to roughly half the width of the retaining channel 6 or half the width of the material below the section 14.

It is due to this „smooth“ rounding between the section 14 and the retaining channel 6 that a latching pressure is built up slowly on further insertion of the tongue 3 into the groove 2 which needs to be overcome when laying the right-hand panel element 1 until the two panel elements are then arranged married as shown in Fig. 1. In this laid condition the two panel elements 1 are mated snug, but also free of stress, the rib 5 being received by the retaining channel 6 free of stress. The latching pressure, which again needs to be overcome for the laid panel element 1 to be lifted out of place, locks the marriage of the two panel elements 1. It is to be noted in addition that the interlocking contours are configured such that at the receiving tongue 3 an oversize is formed. In other words, the dimension at the panel comprising the tongue 3 between the contact surface area 7 and the edge (on the right in Fig. 1) of the rib 5, i.e. the contact location 8c, is larger than the corresponding dimension at the panel comprising the groove, i.e. the dimension between the contact location 7 and that of the retaining channel 6 at which the third contact location 8c is configured. It is furthermore to be noted that the retaining channel is configured in all lightly rounded and that also the underside of the rib 5 is rounded. The third contact location 8c is, however, provided such that the tangent thereto is oriented at least substantially vertically so that, as a result of this, the panel elements are positioned in the horizontal direction relative to each other. The contact location 8d too, is configured in the vicinity of the retaining channel 6 at a rounded portion. The tangent thereto is, however, in the example aspect as preferred, oriented substantially horizontally, generally at an angle to the third contact location 8c so that the panel elements are positioned in the vertical direction relative to each other in thus preventing their release and any difference in level even when the sub-floor is uneven.

Referring now to Fig. 4 there is illustrated in a purely diagrammatic and perspective view a panel element 1 including a longitudinal groove 2 and tongue 3 each respectively. The panel element 1 is oriented ready for laying, i.e. with its fair or decorative face facing upwards. At its ends too, this panel element 1 is provided with an end groove 15 and an end tongue 16. In this arrangement, the longitudinal groove 2 adjoins the right-hand end of the end groove 15 as viewed in the direction „B“ from above and outside of the panel element 1. In maintaining the usual laying direction of the floor covering this thus permits a systematic approach in laying in which, when the work is done with a hammer block, the block is not applied to the side edge of the panel element 1 at which the groove 2 is provided. Instead, the block can now be directly applied to the tongue 3 so that even when the block is not seated squarely any damage to the face surface of the panel element 1 is safely excluded.

The corresponding undercuts of the side groove 2 and tongue 3 respectively, i.e. particularly the configuration of the rib 5 and retaining channel 6 may in some circumstances be selected so pronounced that there could be a problem in horizontally mating in the laying plane. Now, however, such pronounced undercuts are not provided in the end tongue and groove geometry so that by shifting two adjoining panel elements 1 longitudinally relative to each other the end of the shifted panel element 1 can be joined to a further, third panel element 1.

Referring now to Figs. 5 and 6 there is illustrated an aspect in accordance with the invention pertaining to the end groove 15 and the end tongue 16 in which the tongue 16b does not extend in the horizontal plane of the panel element 1 but more or less perpendicular to this plane downwards. The corresponding groove 15b thus opens upwards to receive the tongue 16b.

For such a configuration of the end groove 15b and tongue 16b a method of laying is selected in which the panel element 1 to be laid is located at an angle to the already laid panel element and is then swivelled downwards in the way as already described. Then, however, this panel element is no longer shifted horizontally. Instead, the panel element is arranged right from the start to overlap by its end the end of an already laid panel element 1 so that swivelling down the panel element to be laid causes its end with the tongue 16b to engage the groove 15b of the end of the already laid panel element 1. Although this movement of the lowered panel element 1 is a swivelling movement in actual fact, the mating of groove 15b and tongue 16b can be substantially described as a lowering movement occurring transversely to the face surface area of the panel element 1.

In this arrangement, the groove 15b comprises an undercut and the tongue 16b is contoured with corresponding protuberances, i.e. in the example aspect as illustrated purely diagrammatic with a slightly bulging contour so that on overcoming a latching force with which the tongue 16b is urged into the groove 15b retaining forces can be built up which safeguard a laid panel element 1 from lifting out of place also at its edge portion in now making it possible to configure a smooth floor face surface free of trip edges even in the region of parting locations at the ends of two adjoining panel elements.

Contouring the tongue 16b and groove 15b as shown purely diagrammatically and bulging in Figs. 5 and 6 now permits, in overcoming the corresponding latching forces, non-destructive disassembly of the panel elements 1 and release of their end marriage. It is particularly when the tongue 16b diverges at its underside relatively gradually and recombines further upwards more pronouncedly that this permits comparatively facilitated insertion of the tongue 16b into the groove 15b but results in considerably higher

retaining forces which, however, make it more difficult to disassembly the two panel elements 1. In this case it may be provided for to part the ends from each other not by overcoming the latching forces but by a shifting movement in which groove 15b and tongue 16b are shifted mutually in their longitudinal direction.

The groove 15b comprises to advantage a larger free cross-section than the cross-section of the tongue 16b so that the tongue 16b can be retained „dead“ or by a prestress acting downwards within the groove 15b in thus assuring even for certain dimension tolerances of the tongue 16b that no pressure locations materialize between the tongue 16b and groove 15b urging the tongue 16b upwards and which could produce a trip edge in the region of the parting location between the two ends of adjoining panel elements. Instead, it is now provided for to advantage that contact is made exclusively in each upper region between the groove 15b and tongue 16b so that the tongue 16b is reliably retained in the groove 15b due to the undercut therein.

Referring now to Figs. 7 to 13 there are illustrated further alternatives of the interlocking contours in accordance with the invention at the ends which may be termed in general as groove 15b and tongue 16b. In the embodiment as shown in Fig. 7 the tongue 16b is configured as a downswept protruding ledge on a lip configured at the upper edge of the panel element evident on the right. Swivelling the panel element evident on the right downwards causes the tongue 16b to enter the groove 15b. In the example aspect as shown final interlocking is achieved by an extraneous tongue 17 inserted parallel to the end which is partly received by one side of the tongue and partly in a flank of the groove. It is in this way that the panel evident on the right following the panel laid evident on the left can be interlocked by its end to the adjoining panel element. Safeguarding in a lateral direction (as shown in Fig. 7) is ensured by the tongue and groove joint

whilst safeguarding the panels from being lifted out of place is assured by the extraneous tongue 17.

Referring now to Fig. 8 there is illustrated an embodiment in which safeguarding against side displacement forces is likewise achieved by the tongue and groove joint, except that in this case the tongue is configured at the leading edge of the lip. This further comprises two bevels which are received by the bevels of the groove 15b in thus preventing the right-hand panel from being lifted without it being slightly shifted to the right. This already prevents the panel from lifting out of place so that in this embodiment too, the two panels are non-releasably married in all directions.

Referring now to Fig. 9 there is illustrated an embodiment in which safeguarding against lifting out of place is achieved by the tongue 16b comprising, on the one hand, a bevel whilst, on the other, the non-bevelled flank in the case as shown features several hook-type protuberances 18 preventing the panel on the right from lifting out of place. In other words, the protuberances 18 functioning like a barb or latching hook prevent the non-bevelled flank from passing by the latter to lift the right-hand panel out of place.

Referring now to Fig. 10 there is illustrated how this is achieved by the tongue 16b although featuring two substantially straight flanks, their leading ends being configured somewhat bulged or comprising beads. The groove 15b is correspondingly recessed at least slightly in the corner portions to result in an undercut 20 for latchingly engaging the widenings of the tongue.

Referring now to Fig. 11 there is illustrated an embodiment similar to that as shown in Fig. 9 except that the tongue and the groove now comprise two straight flanks with protuberances 18 configured on the two flanks of the tongue

which maintain the panel evident on the right in the laid position whilst safeguarding it against being lifted out of place.

Referring now to Fig. 12 there is illustrated an embodiment similar to that as shown in Fig. 10, except that the bulge 19 or rounding at the leading end of the tongue element is provided only for one flank, and correspondingly the groove comprising a recess 20 only in a corner portion in which this bulge can be received. In addition, the recess 20, the same as in the embodiment as shown in Fig. 10, is configured somewhat deeper than is necessary for the bulge of the tongue. The reason for this is to endow the surrounding portion with a certain pliancy in permitting a flexible latching action.

Referring now to Fig. 13 there is illustrated in conclusion an embodiment in which safeguarding against it being lifted out of place is assured by the tongue and the groove being dimensioned relative to each other such that the tongue is somewhat wider than the groove to be received so that in the laid condition a press fit materializes which safely maintains the two panels in contact. In this case too, the panel evident on the right is safeguarded against being lifted out of place at its end.

1. Interconnectable panel elements (1) of the same type for configuring a floor covering comprising several interconnectable panel elements (1) of the same type having the following features:
 - two first edges termed sides of each panel element (1) comprise, on the one hand, a groove (2) and, on the other a tongue (3), the tongue (3) comprising at its underside a rib (5) oriented in the longitudinal direction of the tongue (3), and the groove (2) comprising at its underside a retaining channel (6) for receiving the rib (5) of an adjoining panel element (2),
 - the tongue (3) of a panel element (1) located at an angle to the laying plane of a first same-type panel element (1) is insertable into said groove (2) of said first panel element (1) so that said panel element (1) can be swiveled at its longitudinal edge and thereabout downwards into the laying plane of the already laid first panel element (1) in such a manner that the tongue (3) of the panel element (1) to be laid is introduced into the groove (2) of the already laid first panel element (1), and the rib (5) is received in the retaining channel (6),

- said tongue (3) cooperates with said groove (2) of the adjoining same-type panel element (1) such that two married panel elements (1) are safeguarded against parting forces acting in both axes oriented perpendicular to the side of said panel elements (1) and are located as regards angling forces,
 - two second edges termed ends of said panel element (1) are provided with retaining means such as, on the one hand, a groove (15b) and, on the other, a tongue (16b) which form an end joint of two adjoining panel elements (1),
 - said end grooves (15b) and tongues (16b) are married by means of a lowering movement of said panel element (1) on to an already laid panel element (1) of the same type made substantially transversely to said laying plane so that said panel element (1) is safeguarded against forces lifting it out of place, i.e. substantially perpendicular to said laying plane.
2. The panel element as set forth in claim 1, characterized in that the upper edge (10) of said side groove (2) is ramped upwards to the mouth of said groove (2) so as to create an insertion channel (11) for said tongue (3) of a second panel element (1) located at an angle to said laying plane.
 3. The panel element as set forth in claim 1 or 2, characterized in that said side groove (2) and tongue (3) of two married panel elements (1) comprise four defined contact locations (8a, 8b, 8c, 8d).

4. The panel element as set forth in at least one of the preceding claims, characterized in that the material thickness of said panel element (1) above said tongue (3) or groove (2) is at least as thick as the material thickness of said panel element (1) below said tongue (3) and groove (2) respectively.
5. The panel element as set forth in at least one of the preceding claims, characterized in that above said tongue (3) an upper contact surface area (7) extending up to said upper side of said panel element (1) is provided and above said tongue (3) and below said contact surface area (7) a recess (9) is provided for receiving extraneous substances such as glue.
6. The panel element as set forth in at least one of the preceding claims, characterized in that two married panel elements (1) of the same type have contact at both said upper contact surface area (7) defining a joining of said panel elements (1) together and at said retaining channel (6), on the one hand, and at said rib (5), on the other, such that this lower contact surface area (4) thus formed defines a pulling movement parting said two panel elements (1) in said laying plane of said floor, said two contact surface areas (4, 7) producing snug clearance-free contact of said two panel elements (1) with each other.
7. The panel element as set forth in any of the preceding claims, characterized in that the underside of said tongue (3) ramps upwards to the free end of said tongue (3).

8. The panel element as set forth in at least one of the preceding claims, characterized in that the transition from said retaining channel (6) to the section (14) of the under edge of said groove (2) extending between said retaining channel (6) and the side edge of said panel element (1) is oriented rounded with a relatively large radius.
9. The panel element as set forth in at least one of the preceding claims, characterized in that said groove (2) running along the side of said panel element (1) adjoins the right-hand end of said end groove (15).
10. The panel element as set forth in at least one of the preceding claims, characterized in that said end groove (15b) and said end tongue (16b) comprise preferably slotted recesses facing each other, into which an extraneous tongue is insertable.
11. The panel element as set forth in at least one of the preceding claims, characterized in that said end tongue (16b) comprises at least one hook-shaped protuberance at at least one of its side surface areas.
12. The panel element as set forth in at least one of the preceding claims, characterized in that said end tongue (16b) comprises at least one recess configured preferably at its end and said end groove (15b) comprises at least one recess preferably at the corner portions of the bottom of said groove.

Fig. 1

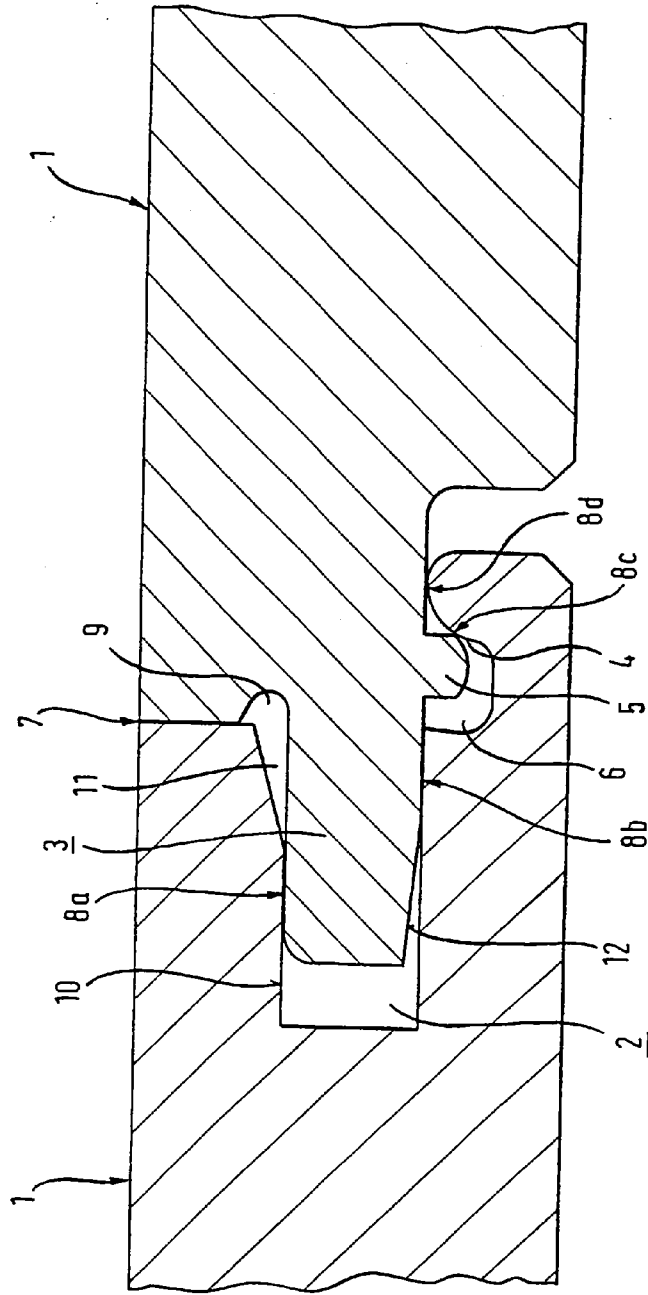

ERSATZBLATT (REGEL 26)

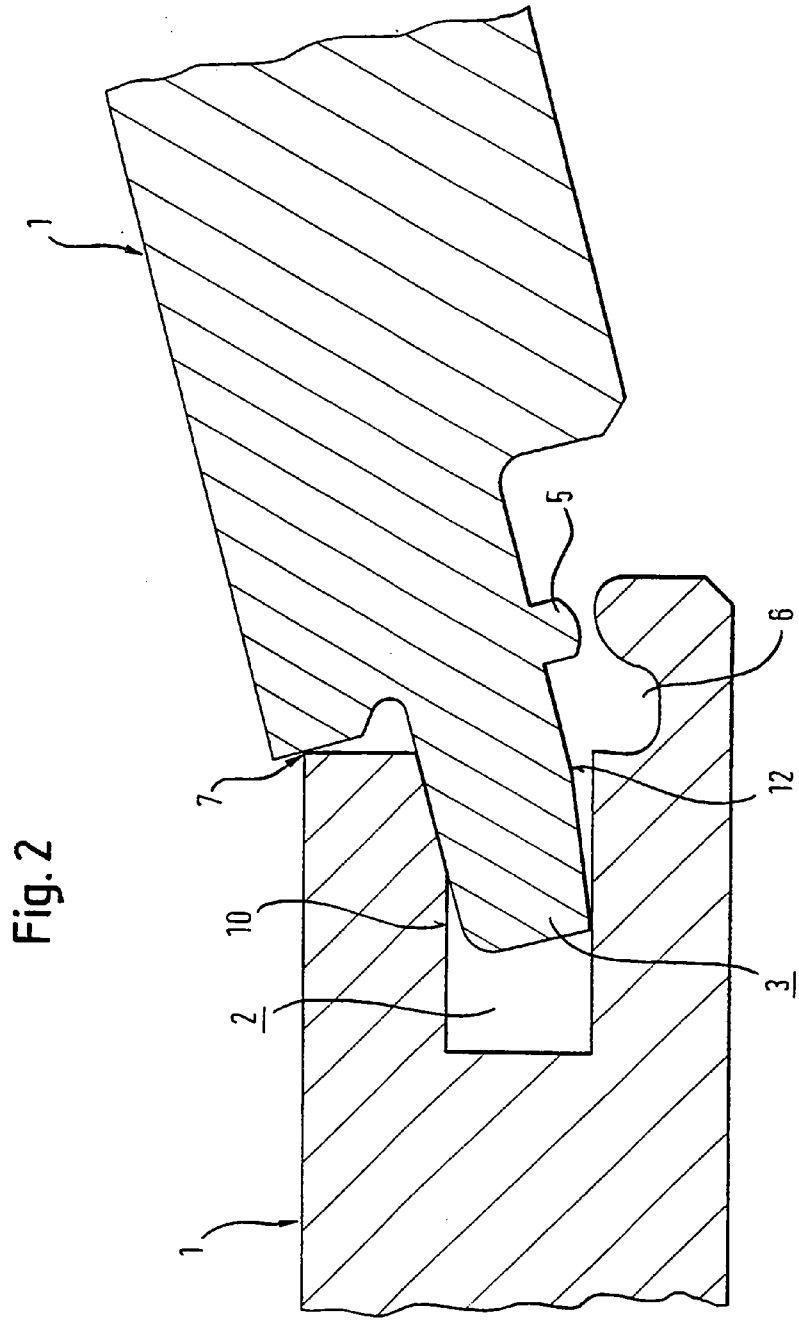
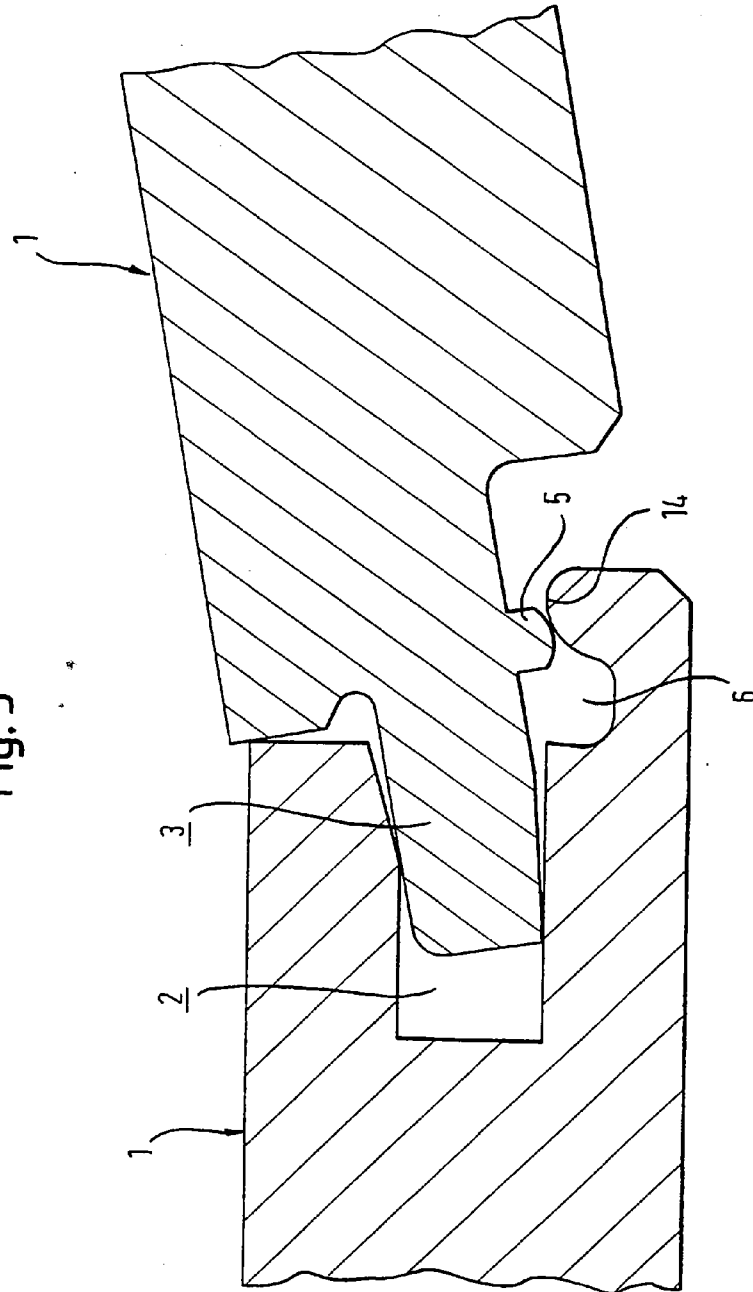

Fig. 2

Fig. 3



ERSATZBLATT (REGEL 26)

4/7

Fig. 4

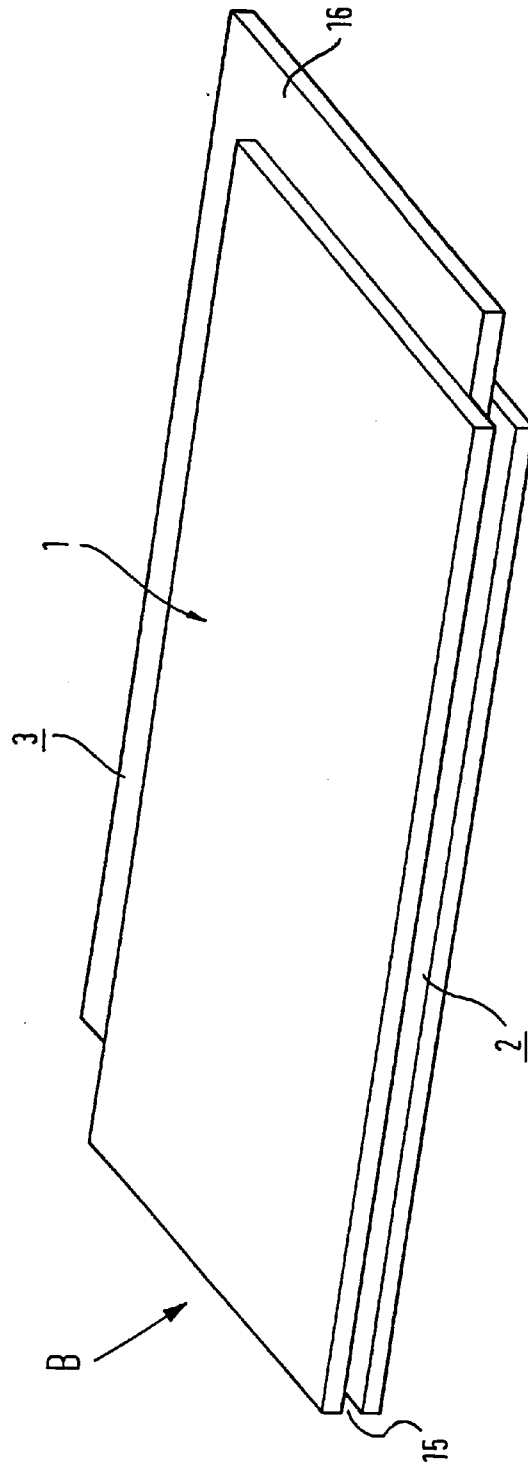

ERSATZBLATT (REGEL 26)

Fig. 5

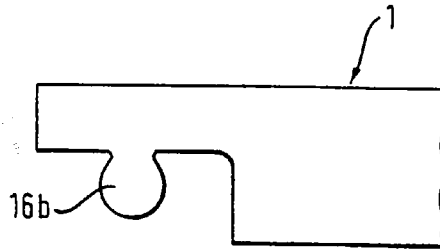

Fig. 6

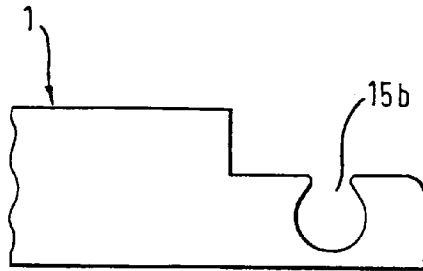

Fig. 7

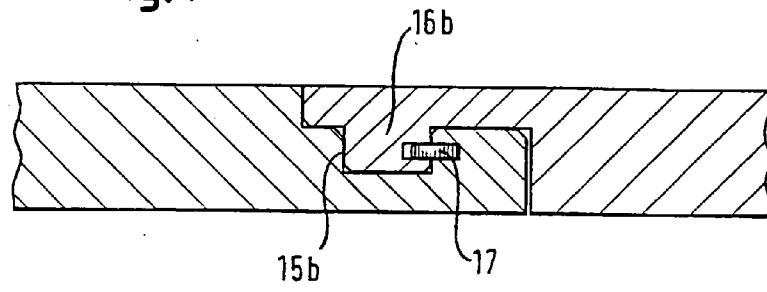

Fig. 8

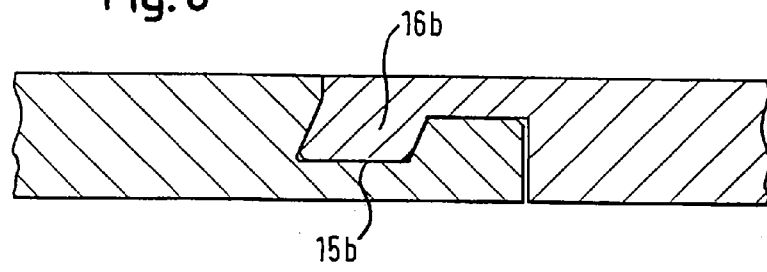

Fig. 9

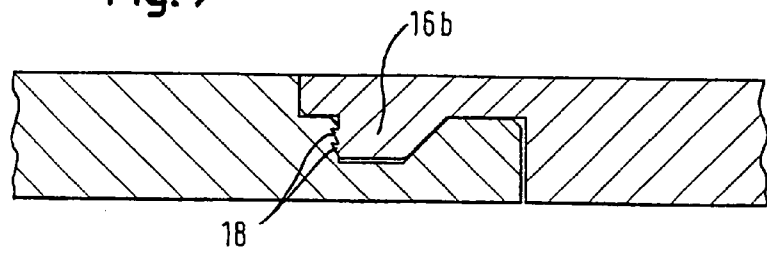

Fig. 10

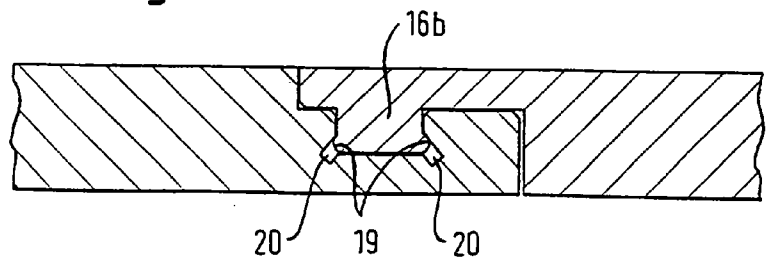

Fig. 11

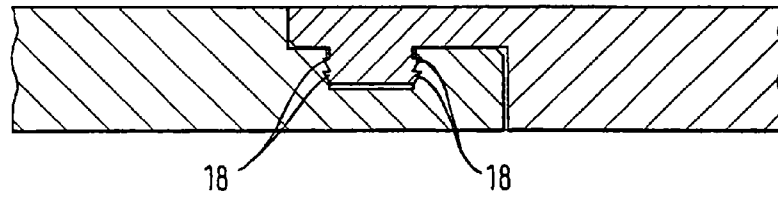

Fig. 12

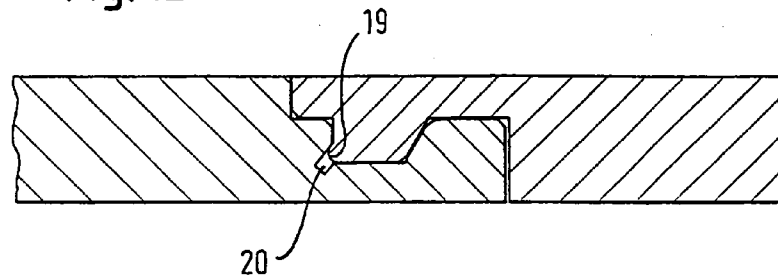

Fig. 13

