

(19) World Intellectual Property Organization
International Bureau



(43) International Publication Date
22 February 2001 (22.02.2001)

PCT

(10) International Publication Number
WO 01/13314 A2

(51) International Patent Classification⁷: G06F 17/60

(21) International Application Number: PCT/ZA00/00135

(22) International Filing Date: 15 August 2000 (15.08.2000)

(25) Filing Language: English

(26) Publication Language: English

(30) Priority Data:
99/4227 15 August 1999 (15.08.1999) ZA

(71) Applicant and

(72) Inventor: MANTZIVIS, Lionel, Nicholas [ZA/ZA]; 46
St Christopher Road, St Andrews, 2007 Bedfordview (ZA).

(74) Agents: DUNLOP, Alan, J., S. et al.; Hahn & Hahn Inc.,
222 Richard Street, Hatfield, 0083 Pretoria (ZA).

(81) Designated States (national): AE, AG, AL, AM, AT, AT
(utility model), AU, AZ, BA, BB, BG, BR, BY, BZ, CA,

CH, CN, CR, CU, CZ, CZ (utility model), DE, DE (utility model), DK, DK (utility model), DM, DZ, EE, EE (utility model), ES, FI, FI (utility model), GB, GD, GE, GH, GM, HR, HU, ID, IL, IN, IS, JP, KE, KG, KP, KR, KZ, LC, LK, LR, LS, LT, LU, LV, MA, MD, MG, MK, MN, MW, MX, MZ, NO, NZ, PL, PT, RO, RU, SD, SE, SG, SI, SK, SL, TJ, TM, TR, TT, TZ, UA, UG, US, UZ, VN, YU, ZW.

(84) Designated States (regional): ARIPO patent (GH, GM, KE, LS, MW, MZ, SD, SL, SZ, TZ, UG, ZW), Eurasian patent (AM, AZ, BY, KG, KZ, MD, RU, TJ, TM), European patent (AT, BE, CH, CY, DE, DK, ES, FI, FR, GB, GR, IE, IT, LU, MC, NL, PT, SE), OAPI patent (BF, BJ, CF, CG, CI, CM, GA, GN, GW, ML, MR, NE, SN, TD, TG).

Published:

— Without international search report and to be republished upon receipt of that report.

For two-letter codes and other abbreviations, refer to the "Guidance Notes on Codes and Abbreviations" appearing at the beginning of each regular issue of the PCT Gazette.

(54) Title: ELECTRONIC COMMERCE SYSTEM

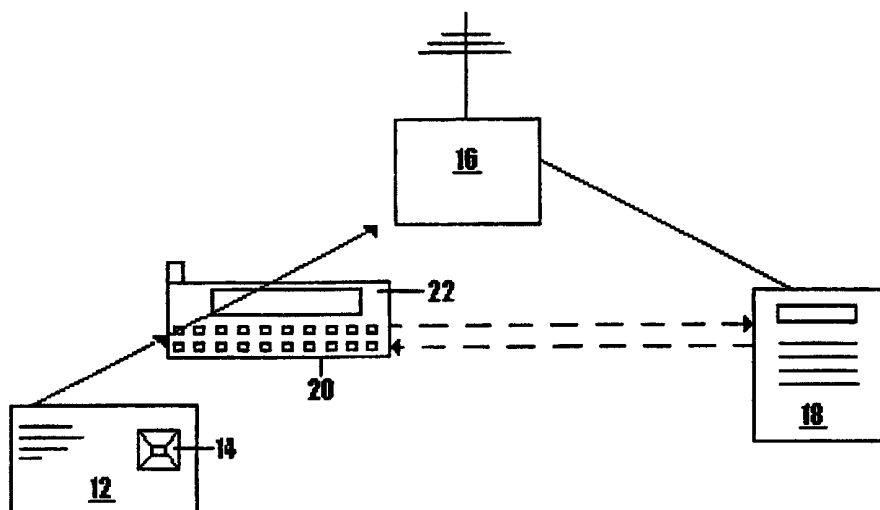

(57) Abstract: The invention provides an electronic commerce connection system comprising a data carrier having provided thereon a set of instructions for permitting access to a mobile communications network, and a set of instructions for connecting to a third party system via the mobile communications network. The system (10) includes a reader (20) for reading the data carrier and a mobile communications unit (22) connectable to the mobile communications network (16) and to the reader (20), the system being configured such that when a user facilitates the reading of the data carrier by the reader, the mobile communications unit is automatically connected to the third party system (18). The data carrier may be a SIM card (14) from a GSM mobile telephone. And may be incorporated into a business or calling card (12).



WO 01/13314 A2

ELECTRONIC COMMERCE SYSTEM

Field of the Invention

5 This invention relates to electronic commerce. In particular, this invention relates to the use of a data carrier in electronic commerce.

Background to the Invention

10 The inventor is unaware of any prior art in this field.

 The inventor is aware that with present technology and technology coming on stream it is becoming technically viable and cost effective to use data carriers, such as smart cards, magnetic strip cards, eeproms, diskettes,
15 and the like, in commercial transactions, even in single commercial transactions whereafter the data carrier will have no further use.

Summary of the Invention

20 According to a first aspect of the invention, there is provided an electronic commerce connection system comprising:

- a data carrier having provided thereon
 - a set of instructions for permitting access to a mobile communications network; and
- 25 - a set of instructions for connecting to a third party system via the mobile communications network;

- a reader for reading the data carrier; and
- a mobile communications unit connectable to the mobile communications network and to the reader,

the system being configured such that when a user facilitates the reading of
5 the data carrier by the reader, the mobile communications unit is automatically
connected to the third party system.

Typically the third party system is a server on a network, for example,
the internet. However, the third party system may be any transaction system,
10 information provision system, banking system, or the like.

The system may include the retrieving of information from the third
party system, once connected. The information may be of the type found on
an internet site, however, the information may be information regarding a
15 product, a person, a company, a transaction, a competition, or the like.

In one embodiment, a SIM card, such as that commonly used on GSM
cellular telephones, is provided with a set of instructions to connect a cellular
telephone or terminal to a cellular telephone network and to then connect said
20 telephone or terminal to an internet server from where information is retrieved
onto said telephone or terminal. Furthermore, where possible, graphics
and/or text are downloaded onto said telephone and/or terminal from the
internet server. This connecting and downloading occurs automatically upon
insertion of the SIM card into said telephone or terminal once said telephone
25 or terminal is activated.

In a specific version of the above embodiment, the SIM card is included in a business or calling card, such as that commonly carried by businessmen, professionals, sales executives, and the like. Usually such card is a paper or plastics card having information printed or otherwise visually represented thereon, for example, the name and address of the company, contact details, 5 qualifications of an individual, and the like.

Where the card is made according to this version of the embodiment of the invention, the SIM including card may include a set of instructions which, 10 when inserted into a cellular telephone or terminal, will automatically connect to the internet server and download information regarding, for example, the company, the individual who handed out the card, company product lines, price lists, and the like, thereby adding an additional dimension to the conventional business or calling card.

15

According to a second aspect of the invention, there is provided a system for conducting a business transaction, said system including the electronic commerce connection system as described above, the business transaction system including:

- 20 - a data carrier having provided thereon
 - a set of instructions for permitting access to a mobile communications network; and
 - a set of instructions for connecting to a third party system via the mobile communications network;
- 25 - a reader for reading the data carrier;

- a mobile communications unit connectable to the mobile communications network and to the reader; and
- a client database on the third party system, which database contains at least some details of clients permitted to conduct business transactions
5 on the system.

The client details on the database may include credit information, personal information for client identification, transaction history, graphic images of clients, and the like.

10

The business transactions system may be used, for example, in vehicle rental transactions, ticket issuing transactions, insurance policy issuing transactions, or the like.

15 Typically, where the transaction is a vehicle rental transaction, the system will include a terminal having the reader provided therein, and a user will permit the reader to read a data carrier which has been previously provided with an instruction set to automatically connect the terminal to the vehicle rental company, the details read from the data carrier will be verified
20 against the database, and if verified, a signal will be transmitted back to the terminal authorizing the transaction. The database may also be populated with entries regarding the transaction, for example, the time and date of the transaction, the value of the transaction, and the like.

The business transaction system may extend to actuation means whereby actions may be performed by the business transaction system, for example, issuing of tickets, provision of vehicle keys, deactivation of a vehicle alarm system, access to a room or a building, or the like.

5

The business transaction system may be used in the rental of hotel rooms, in which case, the data carrier is inserted into a card reader in the hotel lobby or at the door of the room to be rented, and once the renters details have been verified on the database the door unlocks and the renter is

10 given access.

The business transaction system may, in one embodiment, be used to issue insurance policies to passengers on paid transport, for example, busses and taxis.

15

In particular, a passenger boarding a transportation vehicle and who desires insurance for that particular trip will present a data carrier to a reader of a policy issuing terminal which automatically connects to the insurance policy issuing company to register that such a policy has been issued and to

20 process the transaction.

Typically the issuing terminal connects to the insurance policy issuing company only once a batch of policies has been requested, for example, when the vehicle is full or there are no more passengers waiting to board the

25 vehicle.

In some versions, the data carrier is issued by the insurance policy issuing terminal and is not in the possession of the passenger at the time that the transaction is requested. It is also possible to do away with an independent data carrier and all data regarding insurance policies issued may be stored on the insurance policy issuing terminal and/or uploaded to a remote data carrier at the insurance policy issuing company, or the like. In such a case the insurance policy issuing terminal may provide the insured passenger with a receipt indicating that an insurance policy was issued.

The insurance policy issuing operation as described above is particularly advantageous for a high traffic taxi industry, such as a "mini-bus" taxi industry known in South Africa and other developing countries.

According to a further aspect of the invention, there is provided a competition system, the competition system including:

- a data carrier;
- a set of instructions or data provided on the data carrier for uniquely identifying the data carrier;
- a remote computer;
- a data carrier reader for reading the set of instructions or data, said reader being connectable in data communication with the remote computer;
- a database containing competition details provided in data communication with the remote computer; and
- an algorithm for verifying whether an identified data carrier corresponds to a competition winner in the database.

The competition system may include a mobile communication network for permitting the connection to be established between said reader and said remote computer. The mobile communication network may also be used for data communication between the remote computer and the database.

5

Conveniently, the data carrier is included with a fast moving consumer good (FMCG) product, such as a food product, a beverage product, a periodical or magazine, or the like. However, the data carrier may be sold or given away without any accompanying product or services.

10

Where the data carrier is included with an FMCG, the FMCG and the data carrier are conveniently packaged together in order to encourage consumers to buy FMCG's with which such data carriers are provided thereby being permitted to enter competitions.

15

The inventor foresees that the connection system and/or the business transaction system as described above may be used for the competition system.

20

The above disclosure is not intended to be limiting as those skilled in the art will find alternative applications and extensions of the basic invention described above, and all such applications and extensions are included herein as if specifically described.

Description of the Drawings and Examples

The invention may be exemplified, without in any way limiting the scope of the invention, by the following examples and accompanying diagrams.

5

Example 1

This example exemplifies in Figure 1 the use an electronic commerce connection system 10 broadly in accordance with the invention for a business or calling card 12 having a data carrier, in the form of a SIM 14 provided thereon. The SIM 14 includes a set of instructions for permitting access to a mobile communications network 16 and a set of instructions for connecting to a third party system, the server 18 of the card 12 distributor, via the mobile communications network 16.

15

A reader 20 for reading the SIM 14 is provided on a mobile communications unit, in the form of a cellular telephone terminal 22, such as a Nokia™ 9110. The system 10 is configured such that when a user inserts the SIM 14 into the terminal 22, the terminal 22 is connected to the server 18 and information regarding the card 12 is retrieved from the server 18 and is displayed on the terminal 22 without the user having to dial up a connection or carry out any connection functions, i.e. automatically.

The information may be of the type found on an internet site, however, the information may be information regarding a product, a person, a company, a transaction, a competition, or the like.

Usually such card 12 is a paper or plastics card having information printed or otherwise visually represented thereon, for example, the name and address of the company, contact details, qualifications of an individual, and
5 the like. This information is now downloadable from the server 18 upon insertion of the SIM 14 into the terminal 22

Other information which is downloaded to the terminal 22 may be information regarding the company, the individual who handed out the card,
10 company product lines, price lists, and the like, thereby adding an additional dimension to the conventional business or calling card.

In other embodiments the terminal 22 is replaced with a modem (not shown) and the information is downloaded to a separate computer.
15

Example 2

In this example, a business transaction system 50 broadly in accordance with the invention is shown in Figure 2. The system 50 is
20 exemplified as used for vehicle rental transactions.

The business transaction system 50 includes a data carrier 52 having provided thereon a set of instructions for permitting access to a mobile communications network 54 and a set of instructions for connecting to a third
25 party system, in the form of a vehicle rental company transaction server 56, via the mobile communications network 54.

A point of rental terminal 60 includes a reader 62 for reading the data carrier 52 and a mobile communications unit 64 connectable to the mobile communications network 54. The server 56 has a client database which contains at least some details of clients permitted to conduct business transactions on the system 50.

The client details on the database may include credit information, personal information for client identification, transaction history, graphic images of clients, and the like.

10

A user permits the reader 62 to read the data carrier 52 which has been previously provided with an instruction set to automatically connect the terminal 60 to the vehicle rental company server 56, the details read from the data carrier 52 are verified against the database, and if verified, a signal is transmitted back to the terminal 60 authorizing the transaction. The database may also be populated with entries regarding the transaction, for example, the time and date of the transaction, the value of the transaction, and the like.

Actuation means, in the form of electrically operable booms (not shown), locks (not shown), and the like, whereby actions may be performed by the business transaction system, for example, provision of vehicle keys, and deactivation of a vehicle alarm system permits a verified client to drive of in a rented vehicle.

Example 3

In Figure 3, a competition system 80, broadly in accordance with the invention, is exemplified.

5

A user (not shown) purchases an FMCG, in the form of a beverage 82. The cap 84 of the beverage 82 contains a SIM 86 on which a unique identification code has been provided.

10

The user presents the SIM 86 to a reader 88 on a terminal 90, where the SIM 86 is read and the terminal 90 connects to remote computer 92 on which a database has recorded all the unique identification codes of competition winners. The computer 92 has an algorithm which compares the unique identification code read from the SIM 86 to those in the database and if there is a match the user of the SIM 86 is awarded a prize.

15

In one embodiment, the terminal 90 is an Automatic Teller Machine (ATM) of a banking institution and the prize is dispensed from the ATM to a winner once the unique identification code of the SIM 86 has been verified to be a prize winner.

20

In other embodiments, the SIM 86 is inserted into a mobile communications unit, such as that described in Examples 1 and 2. The mobile communications unit contacts a server on which the prize winners are recorded and if the SIM 86 is verified as a prize winner the mobile communications unit displays this information and the prize can be transferred electronically into the winners bank account, or arrangements may be made to have the prize delivered.

25

Claims

1. An electronic commerce connection system comprising:
 - a data carrier having provided thereon
 - 5 - a set of instructions for permitting access to a mobile communications network; and
 - a set of instructions for connecting to a third party system via the mobile communications network;
 - a reader for reading the data carrier; and
 - 10 - a mobile communications unit connectable to the mobile communications network and to the reader,

the system being configured such that when a user facilitates the reading of the data carrier by the reader, the mobile communications unit is automatically connected to the third party system.

15
2. An electronic commerce connection system as claimed in claim 1, wherein the third party system is a server on the internet.
3. An electronic commerce connection system as claimed in claim 1 or
20 claim 2, wherein the third party system is a transaction system, information provision system, or a banking system.
4. An electronic commerce connection system as claimed in any one of
the preceding claims, including the retrieving of information from the third
25 party system, once connected, regarding a product, a person, a company, a transaction, or a competition.

5. An electronic commerce connection system as claimed in any one of the preceding claims, wherein a SIM card, such as that commonly used on GSM cellular telephones, is provided with a set of instructions to connect a cellular telephone or terminal to a cellular telephone network and to then
5 automatically connect said telephone or terminal to a predetermined internet server from where information is retrieved onto said telephone or terminal.

6. An electronic commerce connection system as claimed in claim 5, wherein graphics and/or text are downloaded onto said telephone and/or
10 terminal from the internet server.

7. An electronic commerce connection system as claimed in claim 5 or claim 6, wherein the SIM card is included in a business or calling card, such as that commonly carried by businessmen, professionals, and sales
15 executives.

8. An electronic commerce connection system as claimed in claim 7, wherein the SIM including card includes a set of instructions which, when inserted into a cellular telephone or terminal, will automatically connect to the
20 internet server and download one or more of company details, details of the individual who handed out the card, company product lines, and price lists, thereby adding an additional dimension to the conventional business or calling card.

9. A system for conducting a business transaction, said system including the electronic commerce connection system as claimed in any one of the preceding claims, the business transaction system including a client database on the third party system, which database contains at least some details of clients permitted to conduct business transactions on the system.

10. A system as claimed in claim 9, wherein the client details on the database include credit information, personal information for client identification, transaction history, graphic images of clients, and other transaction security enhancing information.

11. A system as claimed in claim 9 or claim 10, which system is used in vehicle rental transactions, ticket issuing transactions, and insurance policy issuing transactions.

12. A system as claimed in claim 11, in which where the transaction is a vehicle rental transaction, the system includes a terminal having the reader provided therein, and a user will permit the reader to read a data carrier which has been previously provided with an instruction set to automatically connect the terminal to the vehicle rental company, the details read from the data carrier will be verified against the database, and if verified, a signal will be transmitted back to the terminal authorizing the transaction.

13. A system as claimed in claim 12, wherein the database is populated with entries regarding the time and date of the transaction, and the value of the transaction.
- 5 14. A system as claimed in claim 9, which includes actuation means whereby actions may be performed by the business transaction system to issue tickets, provide vehicle keys, deactivate a vehicle alarm system, and/or permit access to a room or a building.
- 10 15. A system as claimed in claim 9 or claim 10, which system is used for the rental of hotel rooms, in which case, the data carrier is inserted into a card reader in the hotel lobby or at the door of the room to be rented, and once the renters details have been verified on the database the door unlocks and the renter is given access.
- 15 16. A system as claimed in claim 9 or claim 10, which system is used to issue insurance policies to passengers on paid transport.
- 20 17. A system as claimed in claim 16, wherein a passenger boarding a transportation vehicle and who desires insurance for that particular trip will present a data carrier to a reader of a policy issuing terminal which automatically connects to the insurance policy issuing company to register that such a policy has been issued and to process the transaction.

18. A system as claimed in claim 17, wherein the issuing terminal connects to the insurance policy issuing company only once a batch of policies has been requested.
- 5 19. A system as claimed in any one of claim 16 to 18, wherein the data carrier is issued by the insurance policy issuing terminal and is not in the possession of the passenger at the time that the transaction is requested.
- 10 20. A system as claimed in any one of claims 16 Or 17, wherein all data regarding insurance policies issued is stored on the insurance policy issuing terminal and/or uploaded to a remote data carrier at the insurance policy issuing company, thereby doing away with the need for each passenger to have a data carrier.
- 15 21. A system as claimed in claim 20, wherein the insurance policy issuing terminal provides the insured passenger with a receipt indicating that an insurance policy was issued.
- 20 22. A competition system, the competition system including:
- a data carrier;
 - a set of instructions or data provided on the data carrier for uniquely identifying the data carrier;
 - a remote computer;

- a data carrier reader for reading the set of instructions or data, said reader being connectable in data communication with the remote computer;
- a database containing competition details provided in data communication with the remote computer; and
- an algorithm for verifying whether an identified data carrier corresponds to a competition winner in the database.

23. A competition system as claimed in claim 22, which includes a mobile communication network for permitting the connection to be established between said reader and said remote computer, which mobile communication network is also used for data communication between the remote computer and the database.

24. A competition system as claimed in claim 23, wherein the data carrier is included with a fast moving consumer good (FMCG) product, such as a food product, a beverage product, or a periodical.

25. A competition system as claim in claim 23, wherein the data carrier is sold or given away without any accompanying product or services.

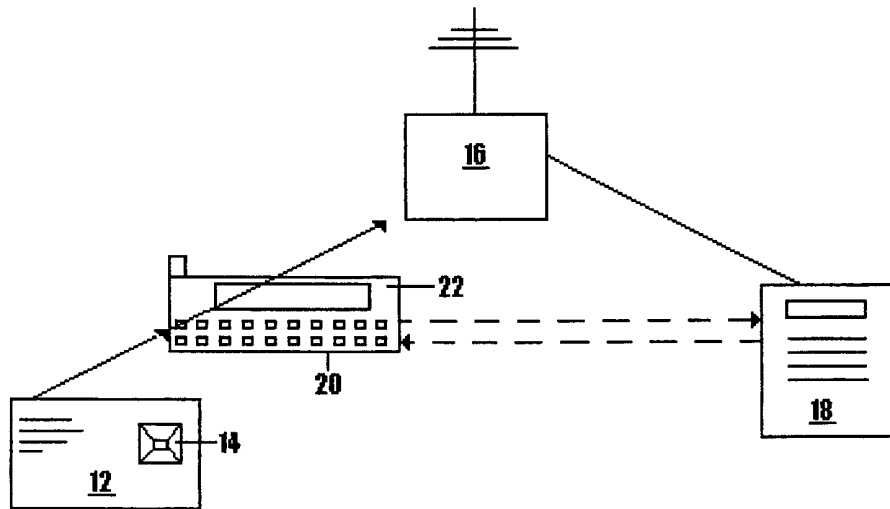

Figure 1

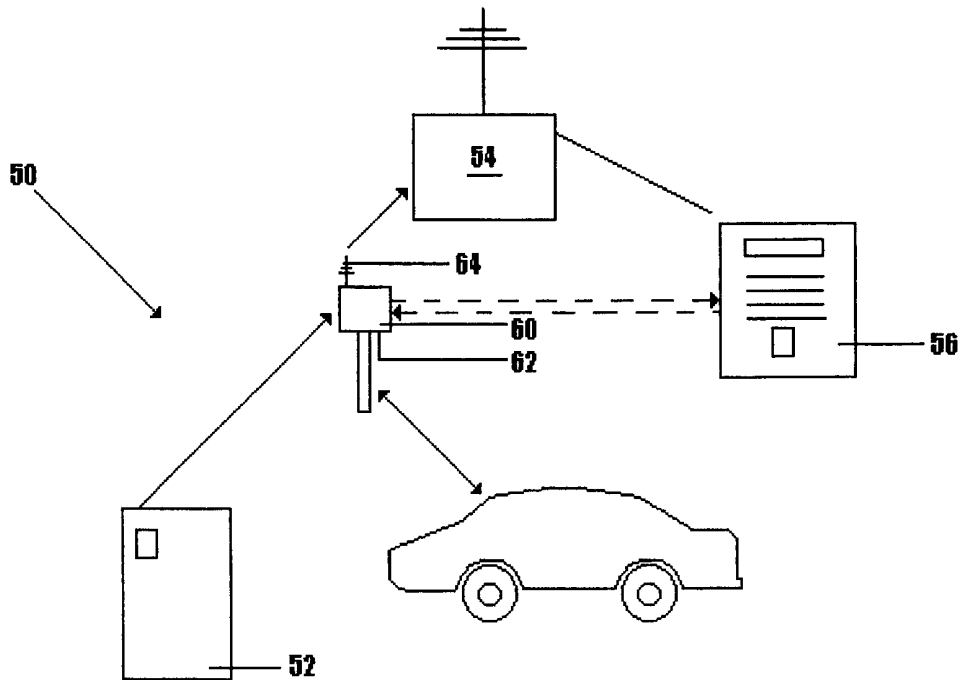

Figure 2

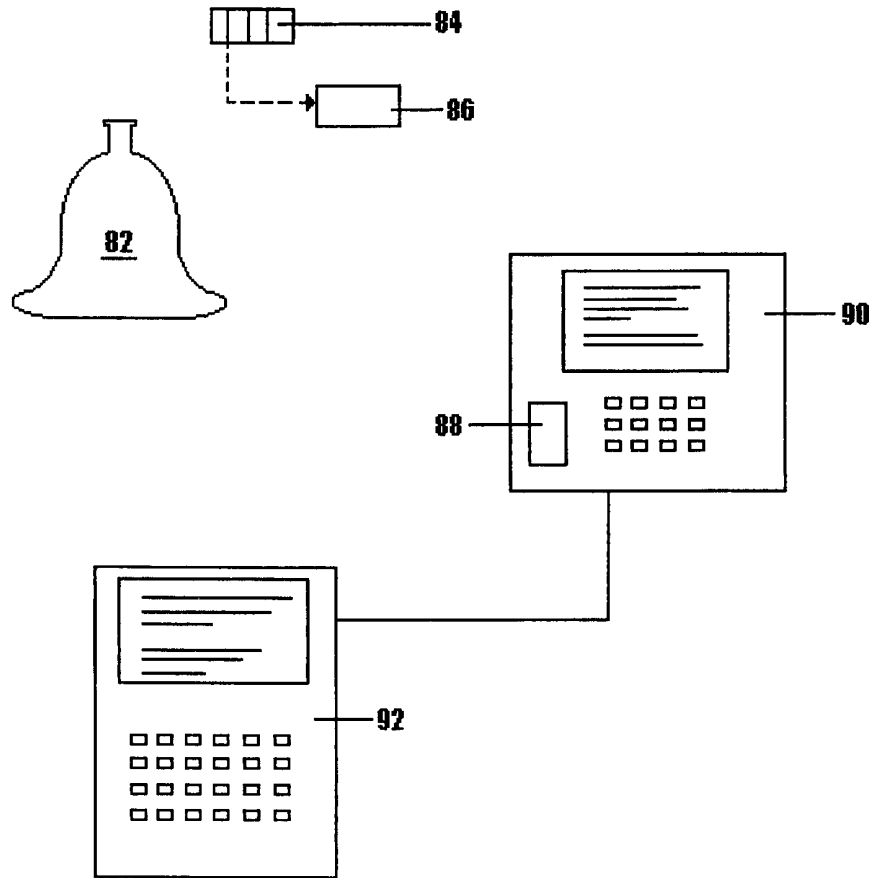

Figure 3