

(No Model.)

J. L. WILLIAMS.
ADJUSTABLE LATHE MANDREL.

No. 470,416.

Patented Mar. 8, 1892.

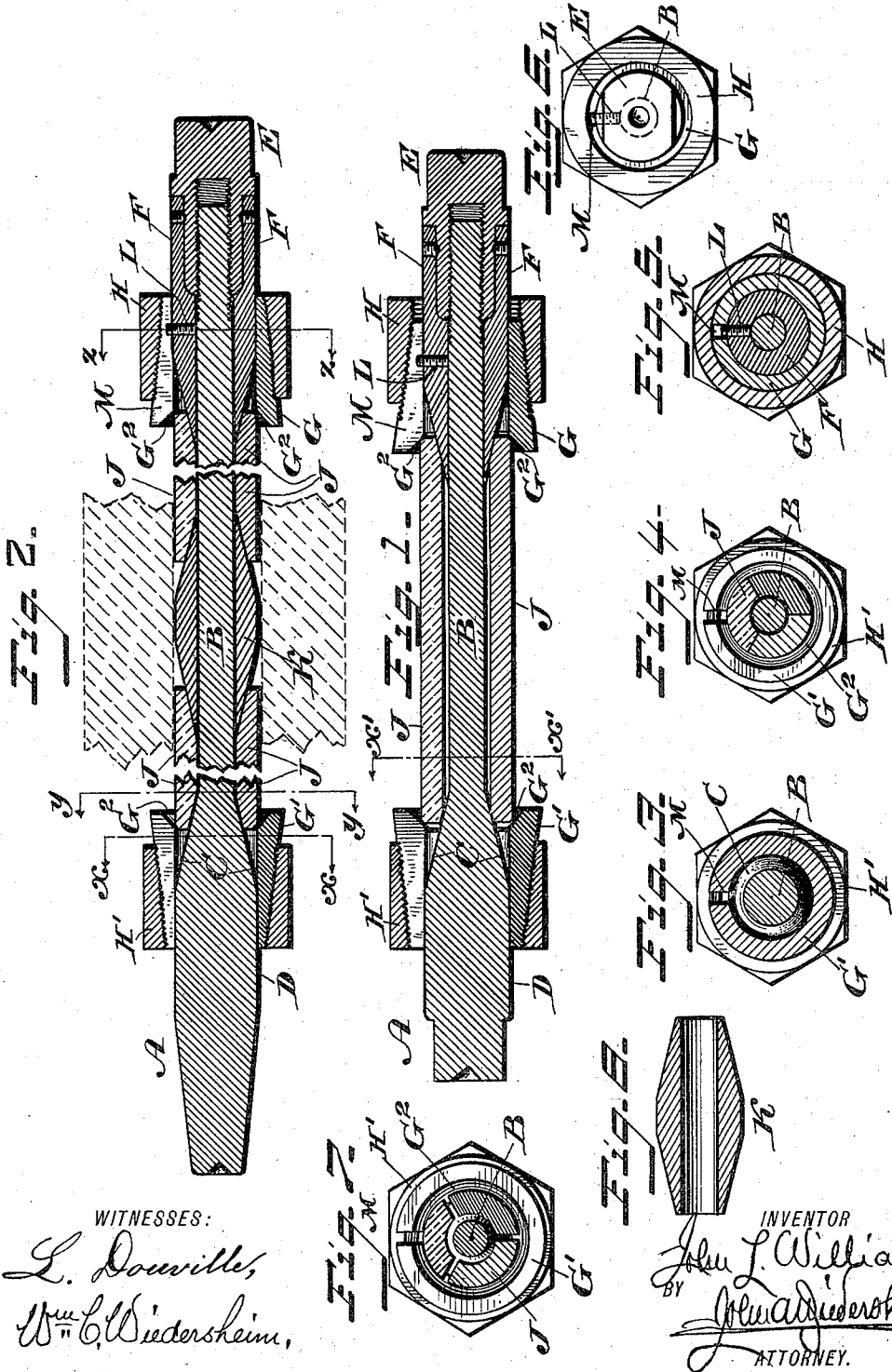

WITNESSES:
L. Douville,
Wm. C. Wiedersheim,

INVENTOR
John L. Williams
BY *Wm. C. Wiedersheim*
ATTORNEY.

UNITED STATES PATENT OFFICE.

JOHN L. WILLIAMS, OF PHILADELPHIA, PENNSYLVANIA.

ADJUSTABLE LATHE-MANDREL.

SPECIFICATION forming part of Letters Patent No. 470,416, dated March 8, 1892.

Application filed August 8, 1891. Serial No. 402,148. (No model.)

To all whom it may concern:

Be it known that I, JOHN L. WILLIAMS, a citizen of the United States, residing in the city and county of Philadelphia, State of Pennsylvania, have invented a new and useful Improvement in Adjustable Lathe-Mandrels, which improvement is fully set forth in the following specification and accompanying drawings.

My invention relates to improvements in adjustable lathe-mandrels; and it consists of a mandrel provided with an adjustable collar for carrying thereon the object to be turned, as will be hereinafter described and definitely claimed.

Figure 1 represents a longitudinal section of a mandrel embodying my invention. Fig. 2 represents a longitudinal section of a modification of the device. Figs. 3, 4, 5, and 7 represent sections on lines $xxyyzz$ of Fig. 2 and $x'x'$ of Fig. 1, respectively. Fig. 6 represents an end view of the device. Fig. 8 represents a longitudinal section of the reinforce central piece or portion of the collar.

Similar letters of reference indicate corresponding parts in the several figures.

Referring to the drawings, A designates a spindle, which forms the fixed part of the mandrel and is adapted to be attached to a suitable rotating portion of the lathe, such as the axle of the head-stock. The said spindle has a main portion B with an inclined shoulder C between it and an enlarged portion D. Mounted on a screw-threaded end of the portion B of the spindle A is a rotatable nut E, to which is secured a sleeve F, having a diameter substantially equal to the portion D of the spindle. The inner end of the said sleeve is beveled on its outer face to correspond with the beveled or inclined shoulder C, for the purpose hereinafter explained.

Movable longitudinally on the portion D of the spindle and a cylindrical portion of the sleeve F are the split sleeves G and G', respectively, the said sleeves having inclined outer faces with screw-threads thereon, on which work the clamping-nuts H H', and have beveled inner faces G² at their inner ends.

Between the sleeves G and G' and on the spindle A is a collar J, on which the work or article to be turned is held. The said collar

is formed of longitudinal sections, as shown in Figs. 4 and 7, having their ends resting on the shoulder C and the beveled end of the sleeve F, and are adapted to be moved in directions so as to either increase or decrease the diameter of said collar.

When a long collar is required to be used, the same is formed of sectional end parts and a central section or strengthening-piece K, formed of a tube having inclined ends corresponding to the shoulder C and the beveled end of the sleeve F, the sections of the end parts having each an end resting on said piece K.

To secure rotation of the sleeve G with the sleeve F, the latter has a pin L, projecting into the slot M in the former.

In adjusting the mandrel the sleeve G and nut H is removed from the device and the hollow piece of material to be turned is placed on the sections of the collar J, after which the said sleeve and nut is replaced, so as to hold the outer ends of the said sections on the spindle. The nut E is then rotated, whereby the beveled end of the sleeve F, entering between the sections of the said collar and the spindle, spreads the said sections at that end thereof until the corresponding end of the bore of the article placed on the collar is filled, when the sleeve G, having its inner beveled end in contact with said collar, is tightly clamped by means of its nut H on the said sleeve F. The nut E is further rotated, causing the sleeve G to bear against its end of the collar J, so that the other end thereof ascends on the inclined shoulder C and within the beveled inner end of the sleeve G' until it has expanded sufficiently to fill the corresponding end of the bore of the article thereon, when the nut H' is screwed on the said sleeve G', tightening the latter in place on the spindle.

The operation of the collar having the strengthening or reinforce piece K in adjusting the mandrel is similar to the operation already described, as can be readily understood.

Having thus described my invention, what I claim as new, and desire to secure by Letters Patent, is—

1. An adjustable mandrel consisting of a

spindle having a main portion with an inclined shoulder and a threaded end, a rotatable nut with sleeve having a beveled end, split sleeves mounted on an enlarged portion
5 of the spindle and the said beveled end of the nut-sleeve, and clamping-nuts for said split sleeves, said parts being combined substantially as described.

2. An adjustable mandrel having a longitudinal sectional collar mounted on a spindle, mechanism secured to said spindle for expanding said collar, and split sleeves and clamping-nuts for binding said collar when
15 adjusted, said parts being combined substantially as described.

3. An adjustable mandrel consisting of a spindle, a sectional expansible collar thereon, a rotatable nut and sleeve for expanding said collar, and a split sleeve with clamping-nut
20 for securing said collar in place on said spin-

dle, said parts being combined substantially as described.

4. An adjustable mandrel consisting of a spindle having a main portion with a screw-threaded end, an enlarged portion, and an intervening inclined shoulder, a nut on said
25 threaded end having a sleeve connected therewith, the said sleeve having a beveled inner end corresponding to the said inclined shoulder, a split sleeve adapted to be rotatably connected with said first-mentioned sleeve and
30 having a beveled inner face on its inner end, a split sleeve with beveled inner face mounted on the enlarged portion of the spindle, and clamping-nuts on said split sleeves, said parts
35 being combined substantially as described.

JOHN L. WILLIAMS.

Witnesses:

JOHN A. WIEDERSHEIM,
R. H. GRAESER.