

G. R. RANDALL.  
RAILWAY SWITCH.  
APPLICATION FILED MAR. 29, 1909.

Patented June 22, 1909.  
2 SHEETS—SHEET 1.

925,722.

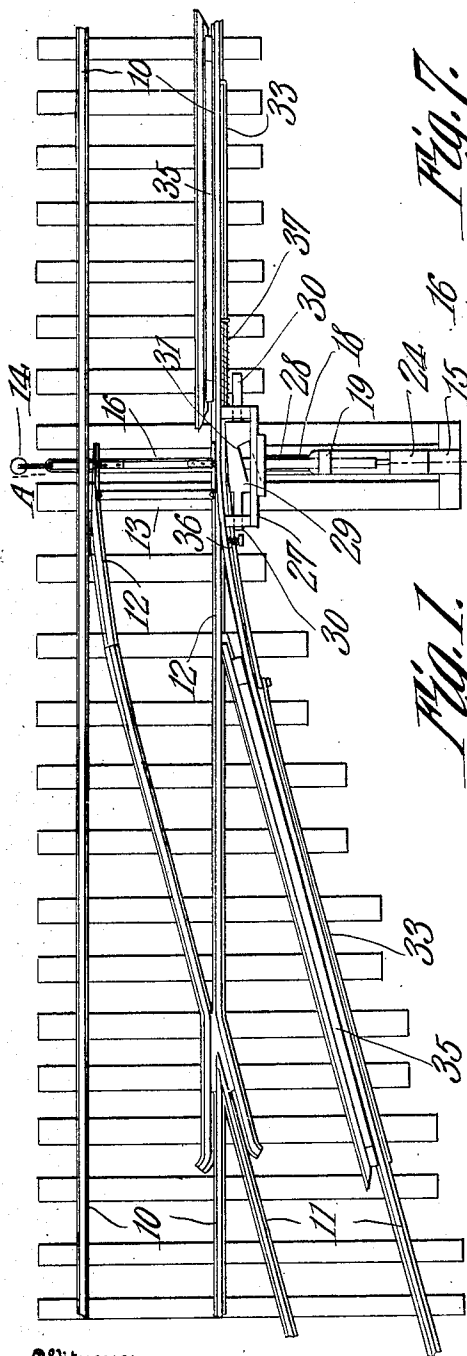

Fig. 1.

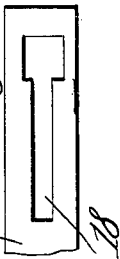

Fig. 7.

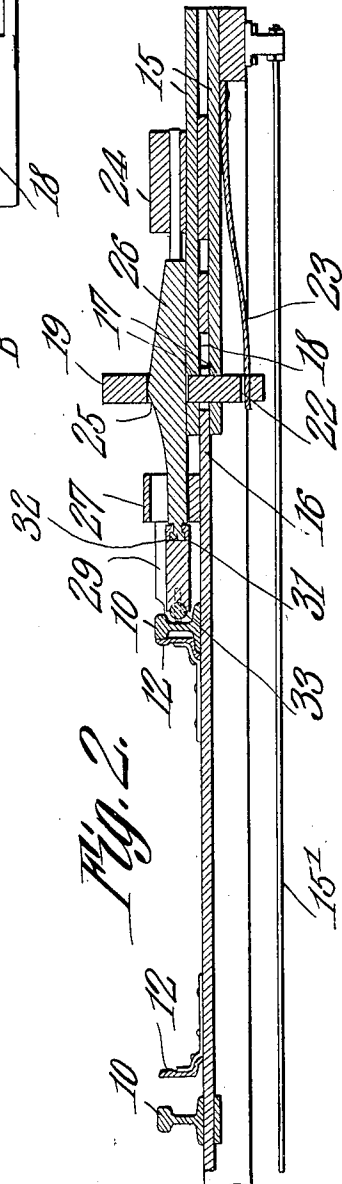

Fig. 2.

Witnesses  
*E. H. ...*  
*E. Daniels*

Inventor  
*George R. Randall.*  
384  
*C. A. Snow & Co.*  
Attorneys

G. R. RANDALL,  
RAILWAY SWITCH.  
APPLICATION FILED MAR. 29, 1909.

925,722.

Patented June 22, 1909.

2 SHEETS—SHEET 2.

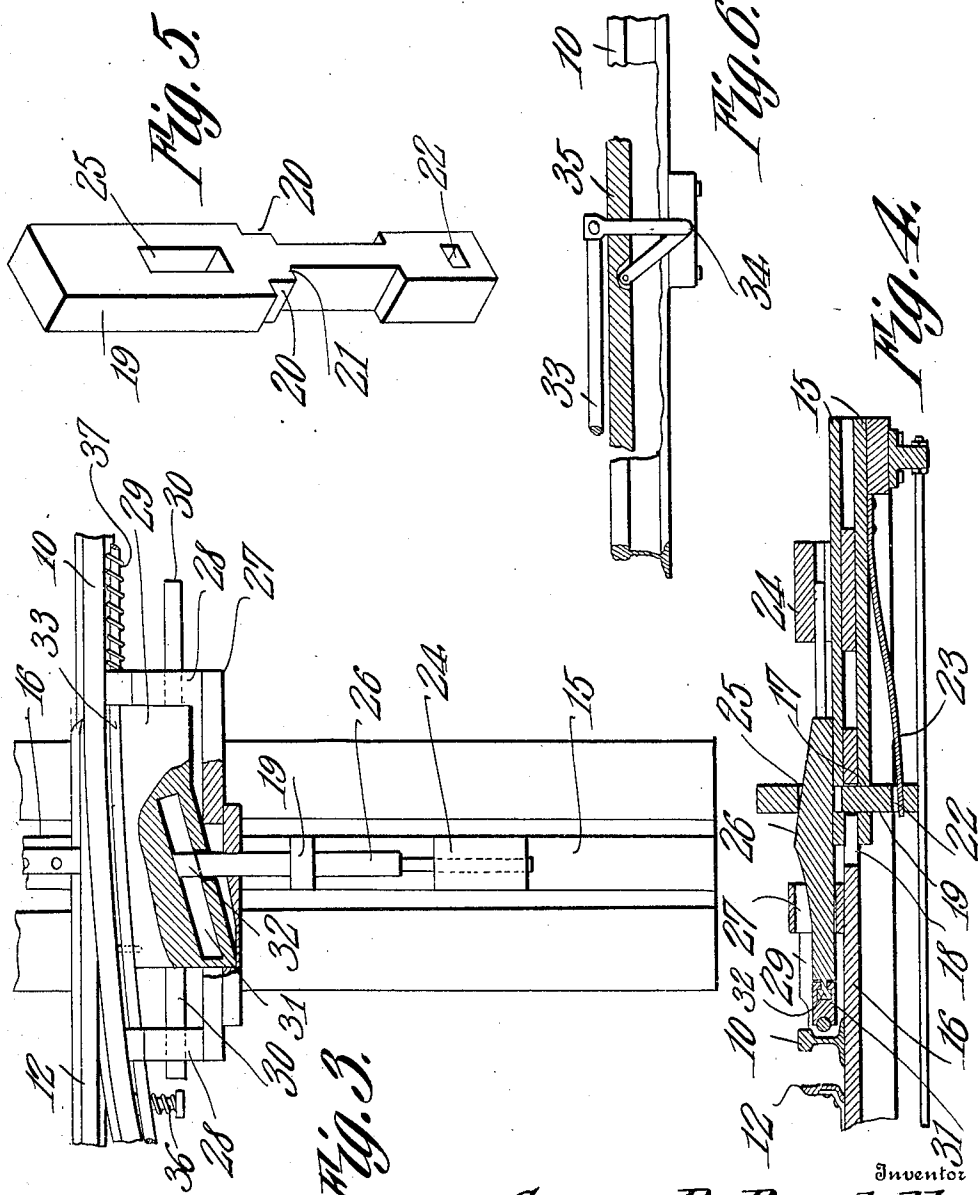

Witnesses

*E. H. Stewart*  
*O. Vanick*

Inventor  
*George R. Randall.*

By *C. Snow & Co.*  
Attorneys

# UNITED STATES PATENT OFFICE.

GEORGE R. RANDALL, OF EARL, NORTH CAROLINA.

## RAILWAY-SWITCH.

No. 925,722.

Specification of Letters Patent.

Patented June 22, 1909.

Application filed March 29, 1909. Serial No. 486,397.

*To all whom it may concern:*

Be it known that I, GEORGE R. RANDALL, a citizen of the United States, residing at Earl, in the county of Cleveland and State of North Carolina, have invented a new and useful Railway-Switch, of which the following is a specification.

This invention relates to railway switches and its principal object is to provide an improved form of such switch arranged to do away with the necessity of a train-man's closing the same after the passage of a train thereover.

Another object of the invention is to provide a switch of the character described with a positive lock to retain the same in open position during the passage of a train or other rolling stock thereover, into or out of the side track or turn-out.

With the above and other objects in view as will become hereinafter apparent, the invention consists in general of a railway switch of what is known as the point type provided with manually operable means for opening the same, a positive locking device to retain the same in open position during the passage of a train or the like, into or out of the side-track or turn-out, an automatic means to restore the same to closed position after the passage of said train.

The invention further consists in certain novel details of construction and combination of parts, hereinafter fully described, illustrated in the accompanying drawings, and specifically set forth in the claims.

In the accompanying drawings like characters of reference indicate like parts in the several views, and:—Figure 1 is a plan view of a switch constructed in accordance with this invention. Fig. 2 is a section on the line "A—B" of Fig. 1. Fig. 3 is an enlarged detail plan view partly broken away. Fig. 4 is an enlarged partial cross-sectional view similar to Fig. 2, showing the parts in another position. Fig. 5 is a detailed view of the latch. Fig. 6 is a detailed view of one of the bell-crank levers and its connections. Fig. 7 is a detail in plan of the end of the bar 16.

The numeral 10 indicates the main line track of a railroad, and the numeral 11 the turn-out or siding track.

At 12 are indicated a pair of switch points of the ordinary construction, in so far as the points themselves are concerned. The switch points 12 are connected by the usual switch bar 13, and are operated from a switch stand

14, of any preferred construction. This switch stand can be located upon either side of the track as may be desired. This switch stand is so arranged as to throw the switch point 12 without locking the same in open position, or, in other words, in that position in which a train will run on or off the side-track or turn out.

The locking device comprises a pair of spaced bars 15, between which is mounted a sliding bar 16. The bars 15 are attached to the switch rod 15' running to the switch stand 14. These bars 15 may be made in the form of a solid casting, or in any other way that may be desired. At the inner ends of the bars 15 there is provided a pair of apertures 17, and the outer end of the bar 16 is provided with a longitudinal slot 18. The slot 18 is T shaped, as clearly shown in the drawings, and the head of the T is positioned at the outer end of the slot. Passing through the apertures 17 and the slot 18 is a latch, 19, provided with rabbeted portions 20, on each side thereof. Between the rabbets 20 there is formed a reduced central portion 21, and the latch beyond this central portion is of greater width than the stem of the T-slot 18, but freely moves up and down in the head of said T-slot. At the lower end of the latch 19 is formed an aperture 22, to act as a seat for a leaf spring 23, securely attached to one of the bars 15.

Upon the top of the bars 15 is mounted a guide 24. An aperture 25, is formed in the latch 19, and through this aperture passes a cam bar 26, the outer end of which moves in the guide 24.

A frame 27, is rigidly attached to the rails, as shown in Fig. 1, and is provided with apertures 28, preferably rectangular in cross sections in the end members of said frame. Within the frame 27 is held a wedge bar 29, provided with reduced ends 30, arranged to pass through the apertures 28. This wedge bar 29, is of such length as to be longitudinally movable within the frame 27. The wedge bar 29 is provided on the outer face thereof with a T-slot 31, and the cam bar 26, is provided with a T-head 32, fitting within the T-slot 31. This T-slot is so arranged that as the wedge bar 29 is moved back or forward in the frame 27, the cam bar 26 will be moved transversely of said frame. For this purpose the T-slot is formed at an angle to the line of motion of the wedge bar.

It is to be noted that the bar 16 is connect-

ed to the switch point 12, and that the parts are so positioned that when the switch is open the head of the T-slot 18 in the sliding bar 16 will be brought into alinement with the apertures 17 in the end of the stationary bars.

Both main and side tracks are provided with suitable guard-rails. These guard-rails are positioned on each side of the frame 27. Rods, 33, are connected to the wedge bar 29, and pass through suitable apertures in the end members of the frame 27, extending thence alongside of the rails. These rods are connected to bell-crank levers 34, so arranged that one of the bell-crank arms lies on the outside of the rails in connection with the rod 33, while the other arm of the bell-crank lever lies between the line rails and guard rails. These bell-crank levers are preferably four in number, but more may be employed if desired, and the arrangement preferred is that two shall be located between each of the guard-rails and its adjacent line-rail. Mounted on the inner arm of these bell-crank levers are presser bars 35, there being one of these bars between each of the guard-rails and the adjacent line-rail.

A spring 36, is arranged to normally hold the switch closed, or in other words, in the position for the train to continue to run on the main line. A second spring 37 is preferably mounted on one of the rods 33, and is so arranged as to normally hold the wedge bar 29 in such position that the cam bar 26 will be forced outward from the frame 27. The cam surface of the cam bar 26 is so proportioned that when the bar is forced out as in the position of the wedge bar 29 just described, the latch 19 will be lifted so that the lower end thereof will be brought up into the head of the T slot 18.

The various parts of the device having now been described, the operation will be clear from the following: As the rolling-stock approaches the switch it moves on to the presser - bar and consequently depresses the same. It is to be noted that it makes no difference whether the rolling-stock approaches from the back track or in the opposite direction from the main line, the presser-bar located toward the approaching rolling-stock will be depressed and actuate the mechanism as now to be described: When this occurs by reason of the peculiar disposition of the bell crank lever, the wedge block 29 will be drawn to such a position as to cause the cam bar to move inward. As the cam bar moves inward the latch 19 is allowed to drop and by reason of the peculiar construction of this part and the T slot in the bar 16, the bars 16 and 15 will be held in extended relations. The switch man may then open the switch in the usual manner, locking it if so desired, since any movement of the switch rod 15' will be communicated to the bar 16,

through the bars 15. The switch man or other attendant may then go about his other business and the train proceed. As soon as the train moves off of the presser-bar the wedge block will be retracted by means of the spring 37, and the latch and cam bar assume the position shown in Fig. 2. As soon as these parts assume this position by reason of the spring 36 the switch point will be forced against the main line rails so as to leave the main line clear. This is accomplished by reason of the latch 19 assuming such position with relation to the T slot that the bars 15 and 16 may telescope.

It will be noted that the switch can only be thrown when rolling-stock is actually on one of the presser-bars and that the switch can then be locked in the usual manner.

It is obvious that the same device may be used to control the ordinary railway signals.

There has thus been provided a simple and efficient device of the character described, for the purpose specified.

It is obvious that many minor changes may be made in the form and proportions of this device without departing from the material principles of the invention. It is not therefore desired to confine the invention to the exact form herein shown and described, but it is wished to include all such as properly come within the scope thereof.

Having thus described the invention, what is claimed as new, is:—

1. In a railway switch, a main line track, a turn-out track, a pair of switch points, manually operable means to open the switch, a latch acting on said switch-opening means to hold the same normally inoperative, a cam acting on said latch, train controlled means to release the cam from the latch and permit opening of the switch, and automatic means to reengage the cam and latch to hold the switch closed.

2. In a railway switch, a main line track, a turn-out track, a switch, manually operable means to open the switch, a vertically movable latch acting on the switch opening means, a cam bar movable transversely to the track and engaging the latch, a wedge movable longitudinally of the track and acting on the cam bar, train-controlled means for actuating said wedge, and automatic means for returning the wedge to its normal position.

3. In a railway switch, a main line track, a turn-out track, a pair of switch-points, manually operable means to open said switch, a latch operated by the train, a cam bar arranged to engage said latch and permit said switch to close, and means controlled by the passage of a train to hold said bar from engagement with said latch, and retain the switch in open position.

4. In a railway switch, a main line track, a turn-out track, a pair of switch-points,

manually operable means to open said switch,  
a latch adapted to hold said switch in open  
position, a cam bar normally holding said  
latch in unlocked position, a wedge bar con-  
5 nected to said cam bar, a spring normally  
holding said wedge bar in position to force  
said cam bar against said latch and place the  
same in unlocking position, presser bars held  
adjacent to said track and adapted to be de-  
10 pressed upon the passage of a train or the  
like, bell-crank levers operated by said  
presser bars, rods connecting said bell-crank

levers with said wedge bar, and a spring to  
hold said wedge bar against movement by  
said presser bars and rods, and a second 15  
spring to close said switch when the latch is  
moved to unlocking position.

In testimony that I claim the foregoing  
as my own, I have hereto affixed my signa-  
ture in the presence of two witnesses.

GEORGE R. RANDALL.

Witnesses:

O. F. AUSTELL,  
T. M. Moss.