



- (51) International Patent Classification:
B07C 5/34 (2006.01) *B07C 5/36* (2006.01)
- (21) International Application Number:
PCT/SE2018/050934
- (22) International Filing Date:
14 September 2018 (14.09.2018)
- (25) Filing Language: English
- (26) Publication Language: English
- (30) Priority Data:
1751115-5 14 September 2017 (14.09.2017) SE
- (71) Applicant: **BOMILL AB** [SE/SE]; Gottorpsvägen 58 A, 218 45 VINTRIE (SE).
- (72) Inventors: **LÖFQVIST, Bo**; Kävlingevägen 22, 222 40 LUND (SE). **HORVATH, Per**; Lyby 3350, 242 93 HÖR-
- BY (SE). **WEHLIN, Karin**; Stora Nygatan 65B, 211 37 MALMÖ (SE).
- (74) Agent: **STRÖM & GULLIKSSON AB**; P.O. Box 4188, 203 13 MALMÖ (SE).
- (81) Designated States (*unless otherwise indicated, for every kind of national protection available*): AE, AG, AL, AM, AO, AT, AU, AZ, BA, BB, BG, BH, BN, BR, BW, BY, BZ, CA, CH, CL, CN, CO, CR, CU, CZ, DE, DJ, DK, DM, DO, DZ, EC, EE, EG, ES, FI, GB, GD, GE, GH, GM, GT, HN, HR, HU, ID, IL, IN, IR, IS, JO, JP, KE, KG, KH, KN, KP, KR, KW, KZ, LA, LC, LK, LR, LS, LU, LY, MA, MD, ME, MG, MK, MN, MW, MX, MY, MZ, NA, NG, NI, NO, NZ, OM, PA, PE, PG, PH, PL, PT, QA, RO, RS, RU, RW, SA, SC, SD, SE, SG, SK, SL, SM, ST, SV, SY, TH, TJ, TM, TN, TR, TT, TZ, UA, UG, US, UZ, VC, VN, ZA, ZM, ZW.
- (84) Designated States (*unless otherwise indicated, for every kind of regional protection available*): ARIPO (BW, GH, GM, KE, LR, LS, MW, MZ, NA, RW, SD, SL, ST, SZ, TZ,

(54) Title: OBJECT CONVEYING AND/OR SORTING SYSTEM

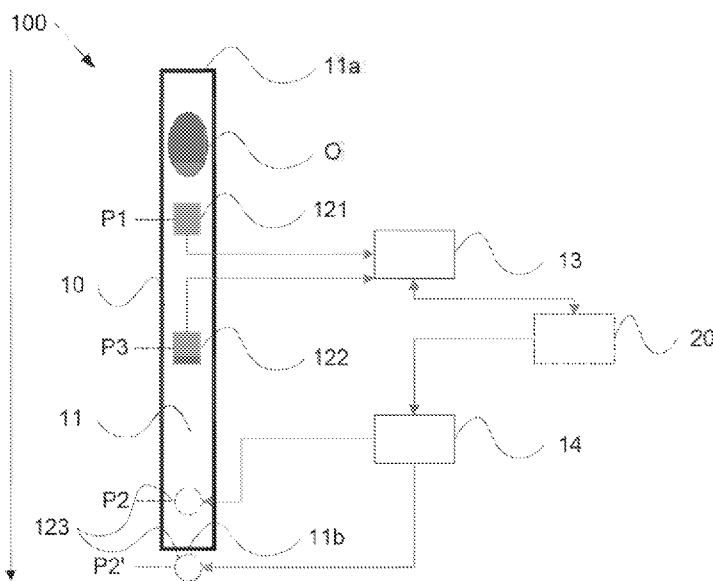

Fig. 2

(57) Abstract: An object conveying system is provided. The system comprises guide plate (10) having at least one channel (11) for conveying an object (O) between a first end (11a) and second end (11b) of the corresponding channel (11). Each channel (11) comprises a first aperture (121) provided at a first longitudinal position thereof (P1). The system further comprises an object measurement unit (13) for conducting an optical measurement associated with a property of the object via the first aperture (121) when the object passes the first aperture (121) towards the second end (11b). At least one ejector unit (14) is arranged to eject the object conveyed on the corresponding channel when reaching a second longitudinal position (P2, P2') located downstream of the first aperture (121) based on the measured property of the object and a timing signal associated with a conveying velocity of the object being conveyed along the channel (11).



UG, ZM, ZW), Eurasian (AM, AZ, BY, KG, KZ, RU, TJ, TM), European (AL, AT, BE, BG, CH, CY, CZ, DE, DK, EE, ES, FI, FR, GB, GR, HR, HU, IE, IS, IT, LT, LU, LV, MC, MK, MT, NL, NO, PL, PT, RO, RS, SE, SI, SK, SM, TR), OAPI (BF, BJ, CF, CG, CI, CM, GA, GN, GQ, GW, KM, ML, MR, NE, SN, TD, TG).

Published:

— *with international search report (Art. 21(3))*

OBJECT CONVEYING AND/OR SORTING SYSTEM

TECHNICAL FIELD

The present invention concerns a system for conveying and ejecting particular
5 objects of a bulk of objects. More particularly, the present invention pertains to a guide
plate having at least one channel for conveying the objects, wherein each channel has a
first aperture utilized for measuring a property of the object while being conveyed in the
channel. At least one ejector unit is arranged to eject the object conveyed on the
10 corresponding channel when reaching a position located downstream of the first
aperture based on the measured property of the object and a timing signal corresponding
to a conveying velocity of the object being conveyed along the channel.

BACKGROUND

It is known to sort objects within a bulk of objects, such as grains, by means of
15 a rotating cylinder or drum, which cylinder has pockets on the inside. This cylinder is
rotating around a substantially horizontal axis, while being aligned with its longitudinal
central axis coinciding with said horizontal axis. The objects, such as granules, are fed
into one end of the cylinder, and as the cylinder rotates the granules will be lifted as
they are captured in the pockets. The pockets are adapted in size and dimensions for
20 receiving one object each. In the bottom of each pocket an opening is provided into the
outside surface of the drum, such that for example light may be sent outside the drum,
through the openings, onto the objects, and being detected on the inside of the drum or
reflected to be detected on the outside of the drum, or vice versa. In this way the object
in the respective pocket may be illuminated with light, and reflection or transmission
25 spectra may be obtained. From this spectra, characteristics of said objects may be
obtained, which may be used to sort or fractionize said bulk of objects based on said
characteristics. One or several collectors may then be placed in the vicinity of the drum,
to receive – after characterization – a specified fraction based on impulses from a
detector. A drum of this kind, and a machine comprising such drum, is disclosed in
30 WO 2004/060585.

A problem associated with such a drum is that the opening may be occluded by
the objects received therein, if the objects get stuck in the opening. Then this pocket will
be useless for the rest of the fractionizing procedure, since the object being stuck not
will be expelled into its corresponding through and no new object can enter the pocket
35 during the next revolution of the drum. Another problem is that only a limited part of
information from the object may be obtained, since the magnitude of information is

governed by the size of the opening. A third problem is that pocket size must be customized after the object size in three dimensions, and the drum must thus be customized after the size of the object. Fourthly, in a drum there is a need for individual active ejection of each object.

5 Another known sorting solution is to allow a bulk stream of objects to drop over a ledge, similarly to a waterfall. A camera or a set of cameras detect properties of the objects during the object's fall, and an ejector unit is arranged to eject objects having certain detected properties in the fall. In this way the ejected objects are sorted out from the original bulk stream of objects. A downside of this solution is that it is rather
10 imprecise, even with an optimized fluid jet stream, since for each ejection also several neighboring objects, e.g. up to 8 to 12 at full capacity, are ejected together with the object having the certain property. A majority of the ejected object may thus not have the certain property triggering the ejection, whereby the ejected group of objects has mixed properties. At the same time, many objects which should not have been ejected
15 will be ejected by this method. This has a detrimental impact on the throughput of the system as well as the capability and degree of precisely sorting out objects having different properties, since for example only one fraction may be separated.

Hence, an improved system for sorting out objects would be advantageous.

20 **SUMMARY**

Accordingly, the present invention preferably seeks to mitigate, alleviate or eliminate one or more of the above-identified deficiencies in the art and disadvantages singly or in any combination and solves at least the above mentioned problems by providing an object conveying system comprising; a guide plate having at least one
25 channel for conveying an object between a first end and a second end of the corresponding channel, wherein the at least one channel comprises a first aperture provided at a first longitudinal position thereof, an object measurement unit for conducting an optical measurement associated with a property of the object via the first aperture when the object passes the first aperture towards the second end, at least one
30 ejector unit arranged to eject the object conveyed on the corresponding channel when reaching a second longitudinal position located downstream of the first aperture based on the measured property of the object and a timing signal associated with a conveying velocity of the object being conveyed along the channel.

Advantageous embodiments are envisioned in the dependent claims below.

BRIEF DESCRIPTION OF THE DRAWINGS

These and other aspects, features and advantages of which the invention is capable of will be apparent and elucidated from the following description of embodiments of the present invention, reference being made to the accompanying drawings, in which

Fig. 1 is a top view of an object conveying system;

Fig. 2 is a top view of the object conveying system of Fig. 1 being provided with a second aperture;

Fig. 3 is a perspective view of a channel of the object conveying system of Figs 1 or 2;

Fig. 4 is a perspective view of the object conveying system of Figs 1 or 2 wherein the guide plate contains a number of adjacently extending channels;

Fig. 5 is a perspective view of the object conveying system of Figs 1 or 2 wherein the guide plate contains a number of adjacently extending channels each having a different length, and where the eject position is located downstream the end of each channel;

Fig. 6 is a perspective view of the object conveying system of Figs 1 or 2 wherein the guide plate contains a number of adjacently extending channels each having a different length, and where the eject position for each channel is located upstream the end of each channel.

DESCRIPTION

The following description is dedicated to an object conveying system, used to sort out objects having certain measured properties from a bulk of objects. Such properties may for example be structure, purity, genomes as well as epigenetic properties of organic granules. Such objects may be organic or inorganic, such as e.g. grains, granules, lentils, nuts, tree nuts, beans, recyclables, minerals, metals, plastics, etc.

Fig. 1 shows a top view of an object conveying system 100. The object conveying system 100 comprises guide plate 10. The guide plate 10 has a longitudinal extension. The guide plate 10 has at least one channel 11 for conveying an object O between a first end 11a and second end 11b of the corresponding channel 11, as indicated by the black arrow. For simplicity Fig. 1 only shows one channel. However, it should be appreciated that any number of adjacently provided channels could be used. Hence, in one embodiment the guide plate 10 comprises a plurality of channels 11.

Each channel 11 comprises a first aperture 121 provided at a first longitudinal position thereof P1. An object measurement unit 13 is provided to conduct an optical measurement associated with a property of an object via the first aperture 121 when said object passes the first aperture 121 towards the second end 11b. The first aperture 121 may optionally be provided with a mesh, grid, or transparent material, such as glass, adapted not to interfere with the optical measurement over the object O, such that the aperture 121 not necessarily is adapted in size to the size of the object, which in turn gives the opportunity to measure in the axial plane over the entire length of the object O. Also, the first aperture 121 may be arranged transversally of a multitude of channels 11, and optionally even interrupting the channels 11 over a certain detection gap. The first aperture 121, arranged transversally of a multitude of channels 11, may be combined with a mesh or grid. At least one ejector unit 14 is arranged to eject the object conveyed on the corresponding channel 11 when reaching a corresponding second longitudinal position P2, P2' located downstream of the first aperture 121 based on the measured property of the object and a timing signal corresponding to a conveying velocity, i.e. the relevant velocity for the movement of the object O towards its corresponding ejector unit 14, of the object being conveyed along the channel 11. When more than one fraction is to be separated from the bulk of objects, each channel 11 may be provided with more than one position P2, such as 2, 3, 4, or 5 positions P2, each position P2 having its corresponding ejector unit 14 to separate a corresponding fraction, based on at least one property of the object O.

The second longitudinal position P2 may either be provided within the boundaries of each channel, as indicated by P2 in Fig. 1, or be provided downstream the second end 11b of the channel. The two second longitudinal positions P2, P2' should be seen as two different alternatives although shown simultaneously in Figs 1 and 2 using dashed lines.

The timing signal may be arranged to activate any one of the corresponding ejector units, such as eject the corresponding object having the property being measured. In order to achieve this it is important to know when said object will pass said second longitudinal position P2, P2' such as to activate corresponding ejector unit at the correct time to eject the object when the corresponding object reaches the second longitudinal position. The timing signal is thus corresponding to the conveying velocity of the object between the first aperture and the second longitudinal position. The time instant at which an ejector unit should be activated may be calculated in different ways.

To this end, in accordance with Fig. 2, at least one second aperture 122 may be provided at a third longitudinal position P3 arranged downstream the first longitudinal position P1, but upstream the second longitudinal position P2, P2'. The second aperture 122 is operatively coupled to the object measurement unit 13, such as to allow for
 5 calculation of the conveying velocity. There may be several second apertures 122, instead of only one, through which combined information may be used to calculate the velocity.

Here, the object measurement unit 13 may be arranged to optically detect the object O passing the first aperture 121 at an associated first time instant T1, and the
 10 object O passing the second aperture 122 at an associated second time instant T2. The conveying velocity of the object may then be calculated as the distance between the first longitudinal position P1 and the third longitudinal position P3 divided by the time duration between the second time instant and the first time instant.

Hence using the commonly known relationship between speed, distance and
 15 time, $s=v*t$;

$$v=(P3-P1)/(T2-T1)$$

The time T_{ACT} at which the object will pass the second longitudinal position
 20 may thus be calculated using the same formula as $t=(T_{ACT}-T1)=s/v=(P2-P1)/v=((P2-P1)(T2-T1)/P3-P1) \rightarrow T_{ACT} = ((P2-P1)(T2-T1)/P3-P1)+T1$.

Accordingly, the timing of the timing signal is dependent on the T_{ACT} for its corresponding fraction to be separated.

Alternatively or in combination the conveying velocity could be calculated by
 25 using measurements only from the first aperture. Here, the object measurement unit 13 is arranged to optically detect the object O entering the first aperture 121 at an associated first time instant T1', and the object exiting the first aperture 121 at an associated second time instant T2'. Similarly to the above, using the formula $s=v*t$, the conveying velocity of the object may be calculated utilizing a time duration, defined by
 30 the difference between the second time instant T2' and the first time instant T1', and a known size of the first aperture 121. Here it should be appreciated that the object measurement unit could detect the first time instant T1' when the front end of the object enters the upstream end of the first aperture and the second time instant T2' when the front end of the object reaches the downstream end of the first aperture. In stead of
 35 calculation of velocity and/or acceleration of the objects a camera could be used to

continuously follow the longitudinal change in position of the objects and give an appropriate signal for its ejection, or in similar ways determine the proper time of ejection.

5 The third longitudinal position P3 may optionally be the same as the first longitudinal position P1, such that the velocity is calculated through the same aperture as an optical measurement associated with a property of an object is calculated.

10 As seen with reference to Figs 3 to 6, each channel 11 may comprise a longitudinally extending base 111 and a pair of sidewalls 112, 113 arranged along either lateral side of the base 111 for limiting the movement of the object O in a lateral direction when being conveyed longitudinally along the base 111. This lateral confinement drastically improves the calculation of T_{ACT} and moreover, aligns the respective object to the downstream second longitudinal position at which the object will optionally be ejected.

15 As indicated in Figs 2 to 6 the first aperture 121 and/or second aperture 122 may be provided straight through the base 111.

20 In order to further reduce the risk of ejecting unwanted objects accidentally being in the neighborhood of the object to be ejected having the measured property, the channels may be provided in different lengths. Hence, a first channel 11a of the guide plate 10 may have a first length and a second channel 11b of the guide plate 10 may have a second length differing from the first length, as shown with reference to Figs 5 and 6.

25 This means that a second longitudinal position P2a, P2'a of a first channel 11a of the guide plate 10 may be provided downstream or upstream a second longitudinal position P2b, P2'b of a second channel 11b of the guide plate 10, as shown in Figs 5 and 6.

30 At the location of the second longitudinal position P2, P2' a third aperture 123 may be arranged for receiving a fluid jet stream. The third aperture 123 may be located within the boundaries of the channels 11. This means that each channel 11 has a separate third aperture 123. In this way the fluid jet stream may focus on each object O to be ejected. As mentioned above, the second longitudinal position P2' may be located downstream the second end 11b of each channel as shown in Fig 5, or it could be arranged upstream the second end 11b of each channel as shown in Fig. 6.

Although not shown, the third aperture 123 may be tapered thus forming an ejection channel having a cross-section reducing through the base 111 of the guide plate 10 towards the object in use.

Depending on the circumstances it may be advantageous to provide the second longitudinal position upstream the second end of the channel, as close downstream to an optional second aperture as possible, or as close to the first aperture as possible if a second aperture is not provided, since this reduces the risk for the object to be subject to a change of velocity after the velocity is calculated, thereby improving the calculation of the time instant T_{ACT} defining when the object passes over the second longitudinal position.

The timing signal could be adjusted to be sent before time T_{ACT} to compensate for optional lag in the ejector unit such as the jet stream hits the second longitudinal position exactly at T_{ACT} .

Each channel 11 may have a width dimensioned to accommodate a single object.

Although the channels in the drawings have a rectangular shape, other shapes are also possible. For example, the side walls 112, 113 need not be parallel, so as to self-center the object O in the channel 11. In such case, at least one of the side walls 112, 113, such as both side walls 112, 113, are inclined in relation to a vertical, in use, or in relation to a general normal to the guide plate 10. For example, each channel may be V-shaped, in a transversal cross-section, wherein the junction of the side walls 112, 113 at the bottom forms the base 111 and the side walls 112, 113 are inclined. In a V-shaped channel there may be a reduced risk of an object being stuck in the channel upon being conveyed as well as the object being self centering regardless of size whilst also the longitudinal alignment of the object O in the channel 10 is improved. Also, each channel may for example be U-shaped in a transversal cross-section. In other alternatives, each channel has an independent shape, being the same or different from other channels in the guide plate 10. For example, one channel may be V-shaped, whilst other channels are U-shaped or rectangular in shape. Also the longitudinal extension of the channel 11 may vary in direction, such as comprising curves in the lateral or vertical direction of the channel 11. These differences in direction may affect and control the relevant velocity of the object O. The differences in direction may result in the channel(s) O comprising an S-shape in the horizontal and/or vertical plane.

The ejector unit 14 may be a fluid jet stream unit, an electromagnetically activated membrane, or piezoelectric punch/thrust.

The object conveying system 100 may comprise a control unit 20 operatively coupled to the ejector unit 14 and/or object measurement unit 13. Hence, the control unit may be arranged to activate each ejector unit 14 based on the timing signal being associated with the calculated time T_{ACT} for each object that has been positively identified to have the property measured by the object measurement unit 13. Accordingly, the control unit 20 may be arranged to eject a particular object based on information of said object being obtained from the object measuring unit 13.

The control unit 20 may further be arranged to receive information from at least one object sensor 21 (not shown) monitoring each object between the first longitudinal position P1 and the second longitudinal position P2, P2', thereby assuring that the object having a certain property to be ejected is ejected at the second longitudinal position P2, P2' by means of the ejector unit 14. The sensor 21 may be a camera. Alternatively, the sensor may be arranged to detect the speed of each object being conveyed along each channel. Hence, the ejecting time T_{ACT} may thus be calculated by the control unit based on a conveying velocity derived from said sensor 21.

CLAIMS

1. An object conveying system (100) comprising;
a guide plate (10) having at least one channel (11) for conveying an object (O)
5 between a first end (11a) and a second end (11b) of the corresponding channel (11),
wherein the at least one channel (11) comprises a first aperture (121) provided at a first
longitudinal position thereof (P1),
an object measurement unit (13) for conducting an optical measurement
associated with a property of the object via the first aperture (121) when the object
10 passes the first aperture (121) towards the second end (11b),
at least one ejector unit (14) arranged to eject the object conveyed on the
corresponding channel when reaching a second longitudinal position (P2, P2') on the
guide plate (10) located downstream of the first aperture (121) based on the measured
property of the object and a timing signal associated with a conveying velocity of the
15 object being conveyed along the channel (11).
2. The object conveying system (100) according to claim 1, further comprising
a second aperture (122) provided at a third longitudinal position (P3) arranged
downstream the first longitudinal position (P1), wherein said second aperture (122) is
20 operatively coupled to the object measurement unit (13) such as to allow for calculation
of the conveying velocity.
3. The object conveying system (100) according to claim 2, wherein the object
measurement unit (13) is arranged to optically detect the object (O) passing the first
25 aperture (121) at an associated first time instant (T1), and the object (O) passing the
second aperture (122) at an associated second time instant (T2), thereby allowing for
calculation of the time (T_{ACT}) at which the associated object will pass the second
longitudinal position (P2) by utilizing the time instant (T1), and time instant (T2),
distance between the first longitudinal position (P1) and third longitudinal position (P3)
30 and distance between the first longitudinal position (P1) and second longitudinal
position (P2).
4. The object conveying system (100) according to claim 1, wherein the object
measurement unit (13) is arranged to optically detect the object (O) entering the first
35 aperture (121) at an associated first time instant (T1) the object exiting the first aperture

(121) at an associated second time instant (T2), thereby allowing for calculation of the time (T_{ACT}) at which the associated object will pass the second longitudinal position (P2) by utilizing the time instant (T1), and time instant (T2), the size of the first aperture and distance between the first longitudinal position (P1) and second longitudinal position (P2).

5
10
15
20
25
30

5. The object conveying system (100) of claim 1 or 2, wherein the at least one channel (11) comprises a longitudinally extending base (111) and a pair of sidewalls (112, 113) arranged along either of the base (111) for limiting the movement of the object (O) in a lateral direction when being conveyed longitudinally along the base (111).

6. The object conveying system (100) according to claim 5 in combination with claim 2, wherein the first aperture (121) and/or second aperture (122) is provided through the base (111).

7. The object conveying system (100) according to any of the previous claims, wherein a first channel (11a) of the guide plate (10) has a first length and a second channel (11b) of the guide plate (10) has a second length differing from the first length.

8. The object conveying system (100) according to any one of the previous claims, wherein the second longitudinal position (P2a, P2'a) of a first channel (11a) of the guide plate (10) is provided downstream or upstream the second longitudinal position (P2b, P2'b) of a second channel (11b) of the guide plate (10).

9. The object conveying system (100) according to any of the previous claims, wherein a third aperture (123) is arranged at the second position (P2, P2') for receiving a fluid jet stream.

10. The object conveying system (100) according to any of the previous claims, wherein the second longitudinal position (P2') is located downstream the second end (11b) of the at least one channel (11).

11. The object conveying system (100) according to any one of the previous claims, wherein each channel (11) has a width dimensioned to accommodate a single object.

5 12. The object conveying system (100) according to any of the previous claims, wherein the ejector unit (14) is a fluid jet stream unit.

10 13. The object conveying system (100) of claim 9, wherein the third aperture (123) is tapered, thus forming an ejection channel having a cross-section reducing through a base (111) of the guide plate (10) towards the object in use.

15 14. The object conveying system (100) according to any of the previous claims, further comprising a control unit (20) arranged to control the operation of the ejector unit (14) and/or object measurement unit (13).

 15. The object conveying system (100) according to claim 14, wherein the control unit (20) is further arranged to eject a particular object based on information of said object being obtained from the object measuring unit (13).

20 16. The object conveying system (100) according to claim 14 or 15, wherein the control unit (20) is further arranged to receive information from at least one object sensor (21) monitoring each object between the first longitudinal position (P1) and the second longitudinal position (P2, P2'), thereby assuring that the object having a certain property to be ejected is ejected at the second longitudinal position (P2, P2') by means
25 of the ejector unit (14).

 17. The object conveying system (100) according to claim 16, wherein the sensor (21) is at least one camera.

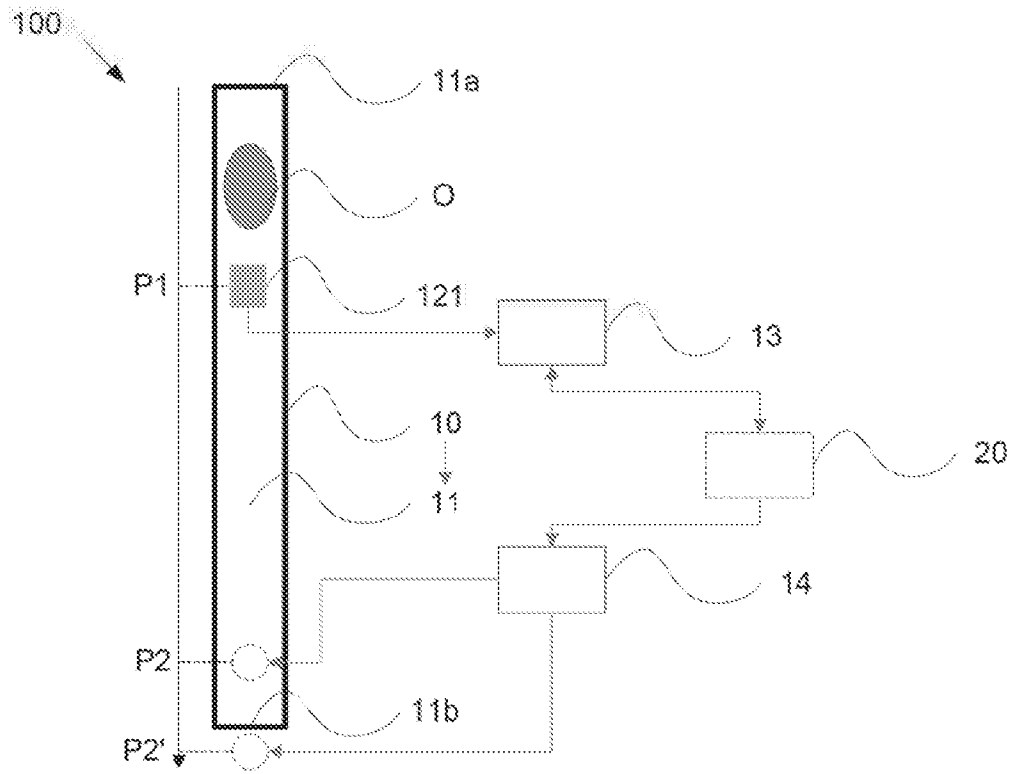

Fig. 1

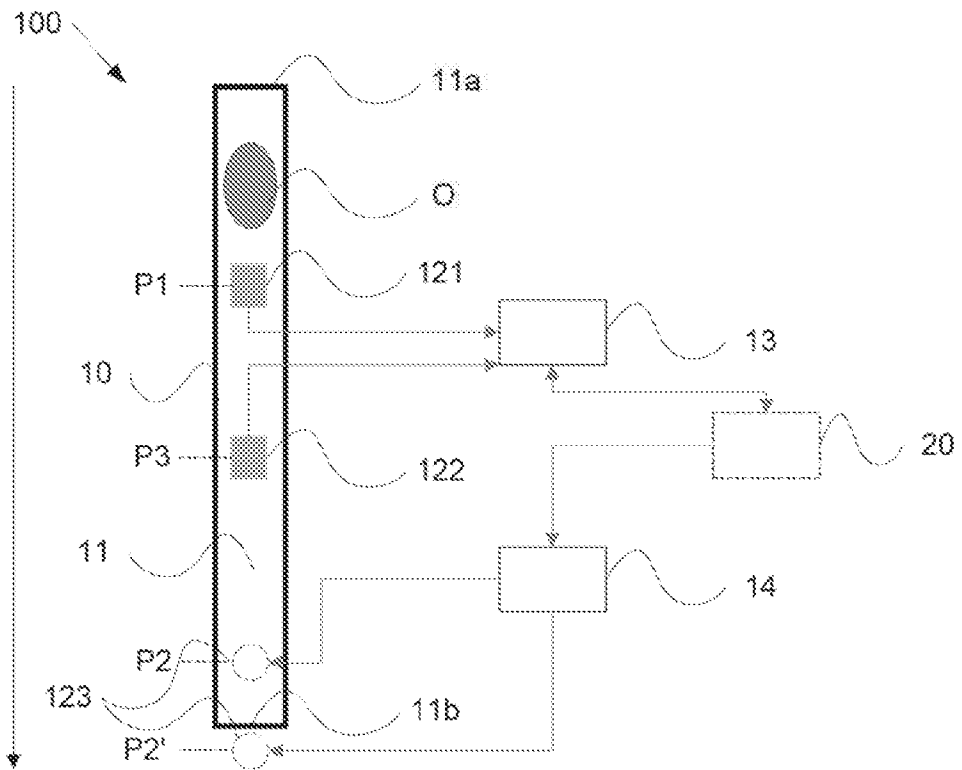
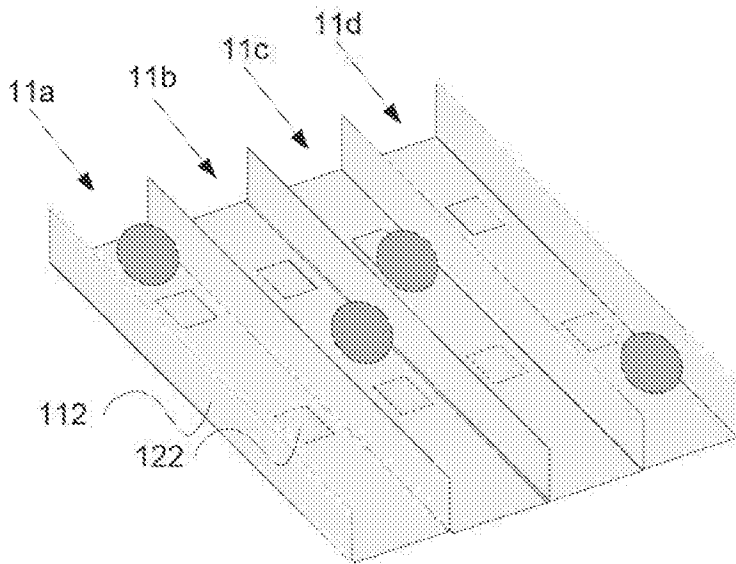
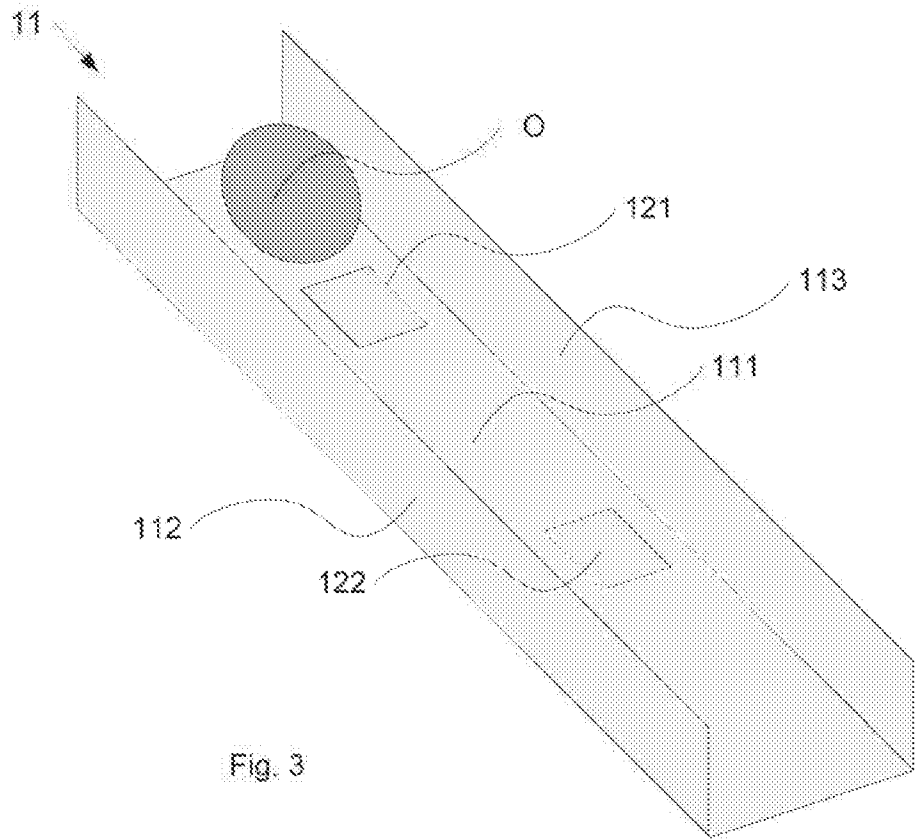

Fig. 2



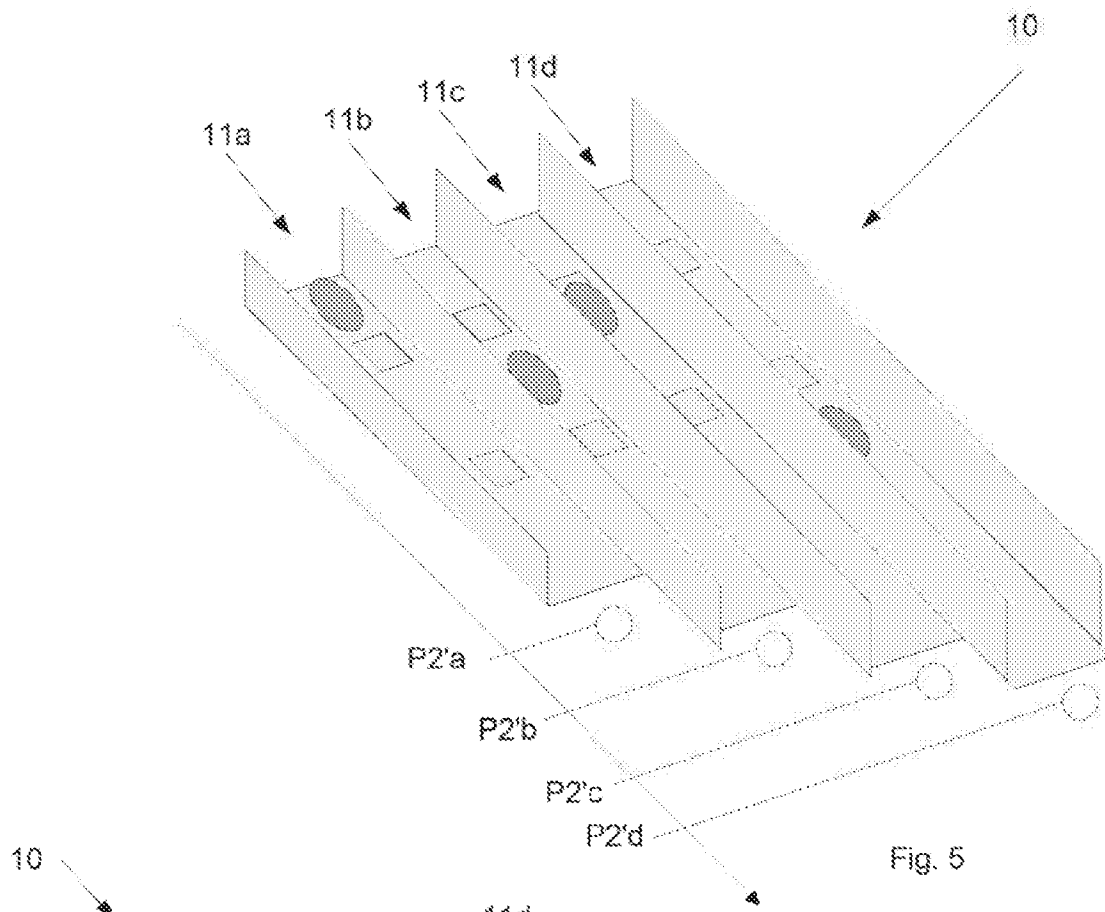

Fig. 5

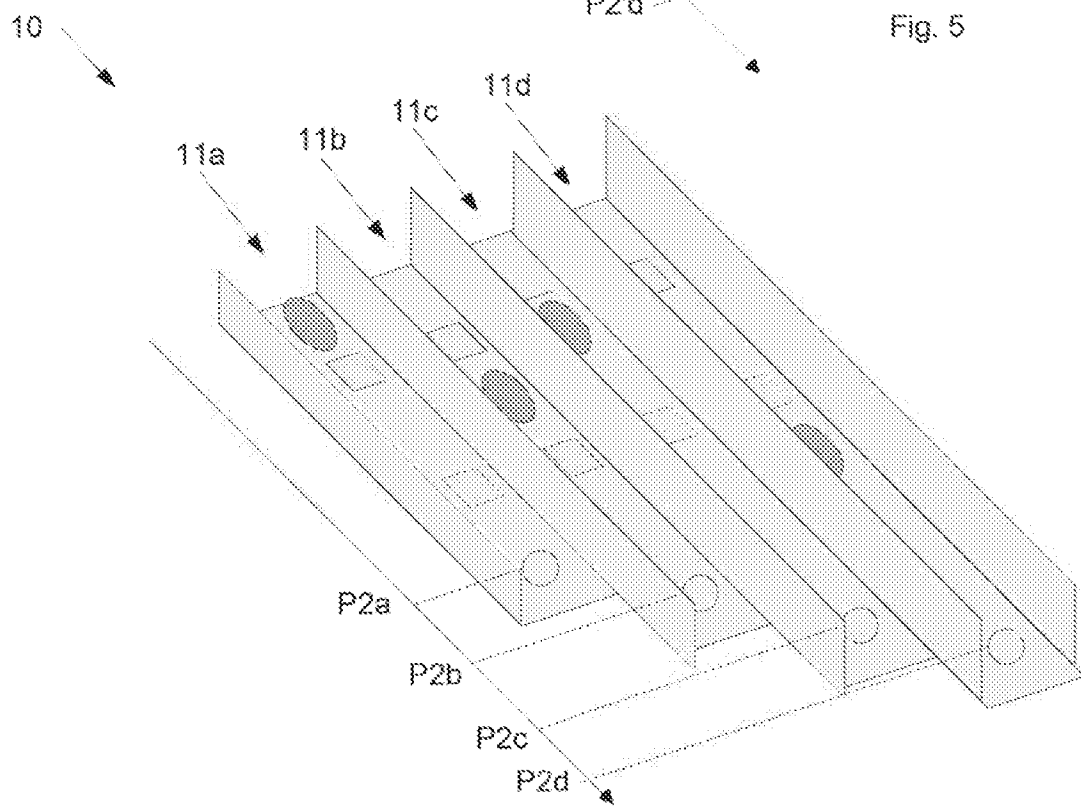

Fig. 6

INTERNATIONAL SEARCH REPORT

International application No.
PCT/SE2018/050934

A. CLASSIFICATION OF SUBJECT MATTER		
IPC: see extra sheet		
According to International Patent Classification (IPC) or to both national classification and IPC		
B. FIELDS SEARCHED		
Minimum documentation searched (classification system followed by classification symbols)		
IPC: B07C		
Documentation searched other than minimum documentation to the extent that such documents are included in the fields searched		
SE, DK, FI, NO classes as above		
Electronic data base consulted during the international search (name of data base and, where practicable, search terms used)		
EPO-Internal, PAJ, WPI data		
C. DOCUMENTS CONSIDERED TO BE RELEVANT		
Category*	Citation of document, with indication, where appropriate, of the relevant passages	Relevant to claim No.
X	US 4848590 A (KELLY LEONARD), 18 July 1989 (1989-07-18); abstract; column 5, line 1 - column 8, line 62; figures 1-6 --	1-17
A	EP 1300200 A1 (KRIEG GUNTHER), 9 April 2003 (2003-04-09); abstract; paragraphs [0021]-[0024]; figures 1-5 --	1-17
A	US 20090050540 A1 (IMAI TAKESHI ET AL), 26 February 2009 (2009-02-26); paragraphs [0002], [0042]-[0046], [0060]; figures 2-3b --	1-17
A	US 4697709 A1 (CODDING ELIAS H), 6 October 1987 (1987-10-06); column 2, line 62 - column 3, line 54; figures 1,2 --	1-17
<input checked="" type="checkbox"/> Further documents are listed in the continuation of Box C. <input checked="" type="checkbox"/> See patent family annex.		
* Special categories of cited documents:		
"A" document defining the general state of the art which is not considered to be of particular relevance		"T" later document published after the international filing date or priority date and not in conflict with the application but cited to understand the principle or theory underlying the invention
"E" earlier application or patent but published on or after the international filing date		"X" document of particular relevance; the claimed invention cannot be considered novel or cannot be considered to involve an inventive step when the document is taken alone
"L" document which may throw doubts on priority claim(s) or which is cited to establish the publication date of another citation or other special reason (as specified)		"Y" document of particular relevance; the claimed invention cannot be considered to involve an inventive step when the document is combined with one or more other such documents, such combination being obvious to a person skilled in the art
"O" document referring to an oral disclosure, use, exhibition or other means		"&" document member of the same patent family
"P" document published prior to the international filing date but later than the priority date claimed		
Date of the actual completion of the international search	Date of mailing of the international search report	
20-12-2018	20-12-2018	
Name and mailing address of the ISA/SE Patent- och registreringsverket Box 5055 S-102 42 STOCKHOLM Facsimile No. + 46 8 666 02 86	Authorized officer Anna Åhlander Telephone No. + 46 8 782 28 00	

INTERNATIONAL SEARCH REPORT

International application No.
PCT/SE2018/050934

C (Continuation). DOCUMENTS CONSIDERED TO BE RELEVANT		
Category*	Citation of document, with indication, where appropriate, of the relevant passages	Relevant to claim No.
A	US 20090200214 A1 (SVATEK DALE ADOLPH ET AL), 13 August 2009 (2009-08-13); paragraphs [0031]-[0032], [0037]; figures 1-4 --	1-17
A	EP 0968772 A2 (SATAKE USA INC), 5 January 2000 (2000-01-05); abstract; paragraphs [0027]-[0031]; figure 1 -- -----	1-17

Continuation of: second sheet

International Patent Classification (IPC)

B07C 5/34 (2006.01)

B07C 5/36 (2006.01)

INTERNATIONAL SEARCH REPORT

Information on patent family members

International application No.

PCT/SE2018/050934

US	4848590 A	18/07/1989	CA	1242260 A	20/09/1988
EP	1300200 A1	09/04/2003	DE	10149505 A1	10/04/2003
US	20090050540 A1	26/02/2009	CN	101372007 B	07/11/2012
			GB	2452164 B	01/08/2012
			JP	2009050760 A	12/03/2009
			JP	5082676 B2	28/11/2012
			US	7968814 B2	28/06/2011
US	4697709 A1	06/10/1987	BR	8604203 A	28/04/1987
			GB	2180062 B	02/05/1990
			JP	6257683 A	13/03/1987
			JP	0670877 U	04/10/1994
			MX	164318 B	03/08/1992
US	20090200214 A1	13/08/2009	US	7743927 B2	29/06/2010
EP	0968772 A2	05/01/2000	BR	9804665 A	09/11/1999