



US009768704B2

(12) **United States Patent**
Haj-Maharsi et al.

(10) **Patent No.:** **US 9,768,704 B2**
(45) **Date of Patent:** **Sep. 19, 2017**

(54) **HYBRID DISTRIBUTION TRANSFORMER HAVING A POWER ELECTRONIC MODULE FOR CONTROLLING INPUT POWER FACTOR AND OUTPUT VOLTAGE**

USPC 323/205-208, 267; 363/34-37, 148-173;
307/45-49
See application file for complete search history.

(75) Inventors: **Mohamed Y. Haj-Maharsi**, Garner, NC (US); **Le Tang**, Cary, NC (US); **Rafael Gutierrez**, Wytheville, VA (US); **Sandeep Bala**, Raleigh, NC (US)

(73) Assignee: **ABB Research Ltd.**, Zurich (CH)

(*) Notice: Subject to any disclaimer, the term of this patent is extended or adjusted under 35 U.S.C. 154(b) by 929 days.

(21) Appl. No.: **12/701,235**

(22) Filed: **Feb. 5, 2010**

(65) **Prior Publication Data**

US 2010/0201338 A1 Aug. 12, 2010

Related U.S. Application Data

(60) Provisional application No. 61/150,591, filed on Feb. 6, 2009, provisional application No. 61/163,311, filed on Mar. 25, 2009.

(51) **Int. Cl.**

G05F 3/04 (2006.01)
H02M 5/10 (2006.01)
H02M 1/42 (2007.01)
H02M 5/45 (2006.01)
H02M 5/458 (2006.01)

(52) **U.S. Cl.**

CPC **H02M 5/10** (2013.01); **H02M 1/4233** (2013.01); **H02M 5/4505** (2013.01); **H02M 5/4585** (2013.01); **Y02B 70/126** (2013.01)

(58) **Field of Classification Search**

CPC **H02M 1/4233**; **H02M 5/10**; **H02M 5/4585**;
H02M 5/4505; **Y02B 70/126**; **G05F 3/04**

(56) **References Cited**

U.S. PATENT DOCUMENTS

3,564,390 A 2/1971 Stratton
4,007,416 A 2/1977 Szatmari
4,086,526 A 4/1978 Grudelbach
4,255,782 A 3/1981 Joyce
4,562,382 A 12/1985 Elliott
4,774,451 A 9/1988 Mehnert et al.

(Continued)

FOREIGN PATENT DOCUMENTS

CN 101335457 A 12/2008
JP 10084674 3/1998

(Continued)

OTHER PUBLICATIONS

Bruno Georges and Jacques Aubin, Application of PLC for on-line monitoring of power transformers, Power Engineering Society Winter Meeting, 2001, IEEE, vol. 2, pp. 483-486.*

(Continued)

Primary Examiner — Gustavo Rosario Benitez

(74) *Attorney, Agent, or Firm* — Taft Stettinius & Hollister LLP

(57) **ABSTRACT**

A hybrid transformer is provided that includes an electro-magnetic transformer and an AC-AC converter with a DC bridge. The AC-AC converter is operable to keep the input voltage and current of the hybrid transformer substantially in phase and to reduce fluctuation in the output voltage of the hybrid transformer in the event of an increase or decrease in the input voltage.

26 Claims, 21 Drawing Sheets

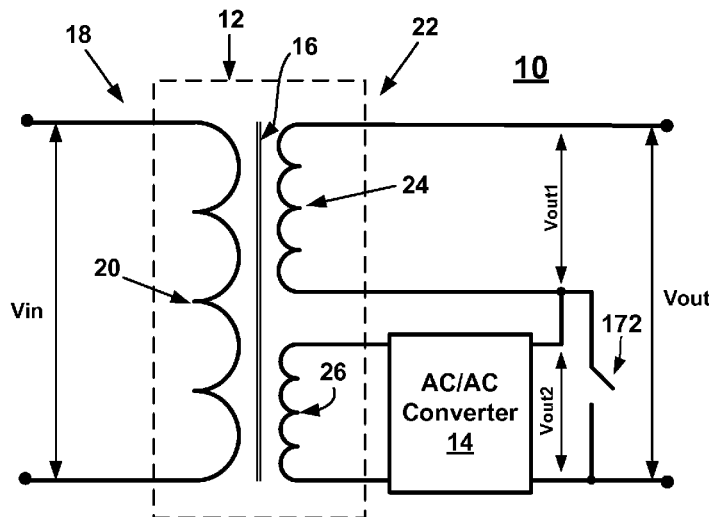

(56)

References Cited

U.S. PATENT DOCUMENTS

5,166,869 A * 11/1992 Hesterman H02M 3/337
363/24
5,179,508 A * 1/1993 Lange et al. 363/16
5,329,222 A * 7/1994 Gyugyi H02J 3/1814
307/102
5,514,915 A 5/1996 Kim et al.
5,570,279 A 10/1996 Venkataramanan
5,625,545 A 4/1997 Hammond
5,724,236 A 3/1998 Oglesbee
5,747,972 A 5/1998 Baretich et al.
5,905,367 A 5/1999 Hochgraf
5,943,229 A 8/1999 Sudhoff
5,949,221 A 9/1999 Edwards
5,991,168 A * 11/1999 Farrington et al. 363/16
6,005,788 A 12/1999 Lipo et al.
6,288,915 B1 9/2001 Stemmier et al.
6,304,006 B1 * 10/2001 Jungreis 307/64
6,310,787 B2 10/2001 Ito et al.
6,340,851 B1 1/2002 Rinaldi et al.
6,472,851 B2 10/2002 Hammond
6,490,178 B1 12/2002 Asayama
6,542,390 B2 4/2003 Bixel
6,545,453 B2 4/2003 Glinkowski et al.
6,559,562 B1 5/2003 Rostron
6,750,563 B2 6/2004 Rostron et al.
6,770,984 B2 * 8/2004 Pai H02M 5/2573
307/46
6,879,062 B2 4/2005 Oates
6,954,366 B2 10/2005 Lai et al.
6,987,331 B2 1/2006 Koeppe et al.
6,995,992 B2 2/2006 Wei et al.
7,049,921 B2 5/2006 Owen
7,050,311 B2 5/2006 Lai et al.
7,362,007 B2 4/2008 Farmer
7,495,410 B2 2/2009 Zargari et al.
7,495,935 B2 2/2009 Chen et al.
7,622,825 B2 11/2009 Brune et al.
2004/0084965 A1 * 5/2004 Welches et al. 307/64
2005/0111245 A1 * 5/2005 Lai et al. 363/125
2005/0201127 A1 * 9/2005 Tracy et al. 363/37
2006/0006850 A1 * 1/2006 Inoue et al. 323/265
2006/0028848 A1 2/2006 Lai et al.
2006/0131960 A1 * 6/2006 Aritsuka H02J 3/1814
307/17
2006/0132062 A1 * 6/2006 Maru et al. 315/291
2006/0221653 A1 * 10/2006 Lai et al. 363/37
2007/0096703 A1 * 5/2007 Jain 323/282
2007/0151272 A1 7/2007 Cosan et al.
2007/0223258 A1 9/2007 Lai et al.
2007/0230226 A1 10/2007 Lai et al.
2009/0001940 A1 1/2009 Sihler et al.
2009/0212758 A1 * 8/2009 Asinovski et al. 323/355
2010/0220499 A1 9/2010 Haj-Maharsi
2012/0087157 A1 * 4/2012 Huang H02M 7/5387
363/37

FOREIGN PATENT DOCUMENTS

JP 2004104909 4/2004
WO 2010091260 8/2010

OTHER PUBLICATIONS

IEEE, IEEE Standard 100-2000, Year 2000, p. 791, Digital Object Identifier: 10.1109/IEEESTD.2000.322221.*
L.-S.Lai, A.Maitra, A.Mansoor, and F.Goodmann, "Multilevel Intelligent Universal Transformer for Medium Voltage Applications," in

Conf.Rec. of IEEE IAS Annual Meeting, Hong Kong, China Oct. 2005 pp. 1893-1899.
J.-S.Lai, A.Maitra, A.Mansoor, and F.Goodmann, "Performance of a Distribution Intelligent Universal Transformer under Source and Load Disturbances," in Conf.Rec.of IEEE IAS, 41st. Annual Meeting, Tampa, FL, Oct. 2006 pp. 719-725.
Ronan, JR., E.Sudhoff, S.Glover, S., and D.Galloway, "A Power Electronic-Based Distribution Transformer," IEEE Transactions on Power Delivery, Apr. 2002, pp. 537-543.
Oscar C. Montero-Hernandez and Prasad N. Enjeti, "Ride-Through for Critical Loads-Exporing a Low Cost to maintaining Continuous Connections between buildings and/or industrial systems," IEEE Industry Applications Magazine—Nov./Dec. 2002—www.IEEE.ORG/IAS.
Z.Fedyczak, J.Kaniewski and M.Klyta, "Single-Phase Hybrid Transformer Using Matrix-Reactance Chopper with Cuk Topolog," in Power Electronics and Applications, 2007 European Conference, Aalborg, Denmark, pp. 1-10.
Jih-Sheng Lai, "Designing The Next Generation Distribution Transformers: New Power Electronic-Based Hybrid and Solid-State Design Approaches," Proceedings of the Latest International Conference Power and Energy Systems, Feb. 24-26, 2003, Palm Springs, CA pp. 262-267.
M.Kang, P.Enjeti and I.Pitel, Analysis and Design of Electronic Transformers for Electronic Power Distribution System in IEEE Industry Applications Society Annual Meeting, New Orleans, LA Oct. 5-7, 1977.
E.C.Aeloiza, P.N.Enjeti, L.A.Moran and I.Pitel, "Next Generation Distribution Transformer: To Address Power Quality for Critical Loads," in Power Electronics Specialist Conference, 2003, PESC'03, 2003 IEEE 34th Annual Meeting pp. 1266-1271.
Z.Fedyczak and J.Kaniewski, Modeling and Analysis of Three-Phase Hybrid Transformer Using matrix Converter, in Compatibility in Power Electronics, 2007, CPE'07, Gdansk, Poland pp. 1-6.
E.R.Ronan, Jr., S.D.Sudhoff, S.F.Glover and D.L.Galloway, "Application of Power Electronics To The Distribution Transformer," in Applied Power Electronics Conference and Exposition, 2000. APEC2000. 15th Annual, New Orleans, LA., Feb. 6-10., pp. 861-867.
P.K.Banerjee, M.A.Choudhury and Golam Toasha Rasul, "AC Voltage Regulation by Switch Mode Buck-Boost Voltage Controller," vol. EE 31, No. I&II, Dec. 2004, pp. 27-31.
A.Julian, D.Divan, T.Lipo, F.Nozari, P.Mezs, "Double Bride Resonant DC Link Converter with Variable Input and Output Frequency," Research Report 96-07, University of Wisconsin-Madison, College of Engineering, Madison, WI 53706-1691.
J.-S.Lai, A.Hefner, A.Maitra and F.Goodmann, Characterization of a Multilevel HV-IGBT Module for Distribution Applications, in Industry Applications Conference, 2006. 41st. IAS Annual Meeting, Conference Record. Tampa, FL, pp. 747-753.
Hefner et al., "Recent Advances in High-Voltage, High-Frequency Silicon-Carbide Power Devices" The 2006 IEEE Industry Applications Conference Forty-First IAS Annual Meeting, Conference Record of, IEEE, Piscataway, NJ, US, Oct. 1, 2006 (Oct. 1, 2006), pp. 330-337, XP031026053, ISBN: 978-1-4244-0364-6.
"Feasibility Assessment for Intelligent Universal Transformer," TR-1001698, Final Report, Dec. 2002, EPRI, 3412 Hillview Av Palo Alto, California 94304., www.epri.com.
Amendment "B"—U.S. Appl. No. 12/713,766.
Second Office Action—U.S. Appl. No. 12/713,766.
Amendment "A"—U.S. Appl. No. 12/713,766.
First Office Action—U.S. Appl. No. 12/713,766.
Chinese Office Action, CN201080009629.2, Nov. 6, 2015.
Chinese Office Action, CN201080009629.2, Nov. 6, 2015, English Translation.

* cited by examiner

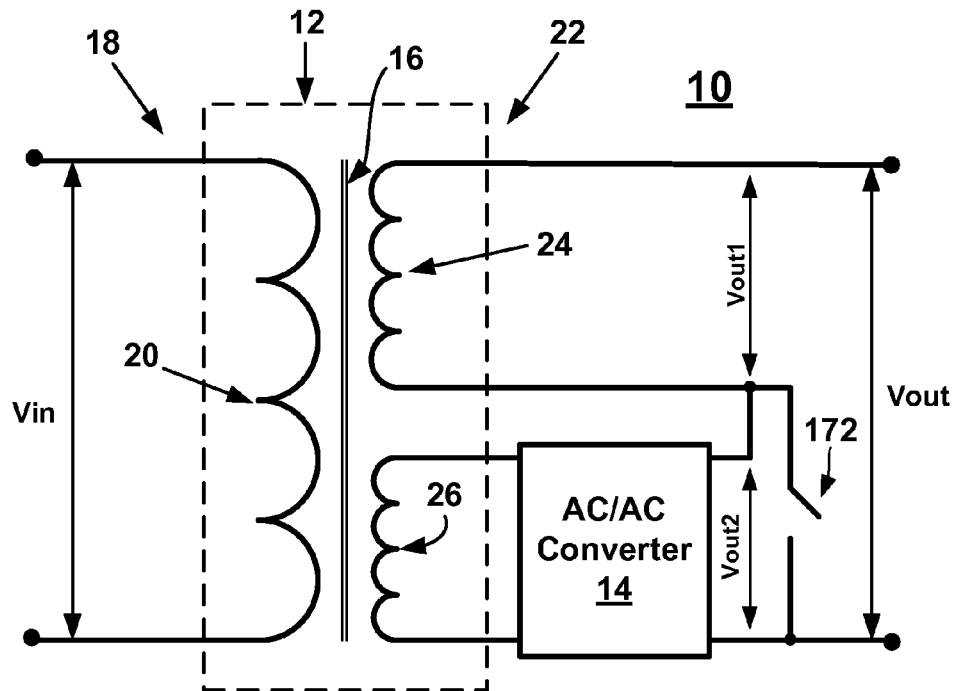

Fig. 1

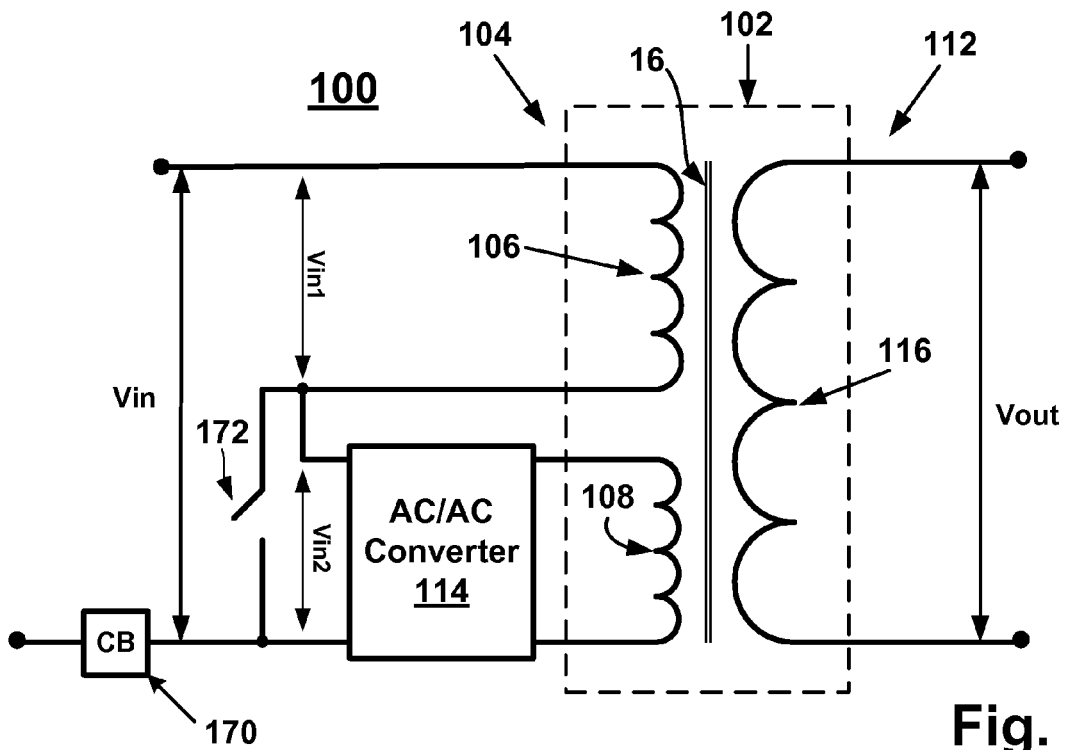

Fig. 2

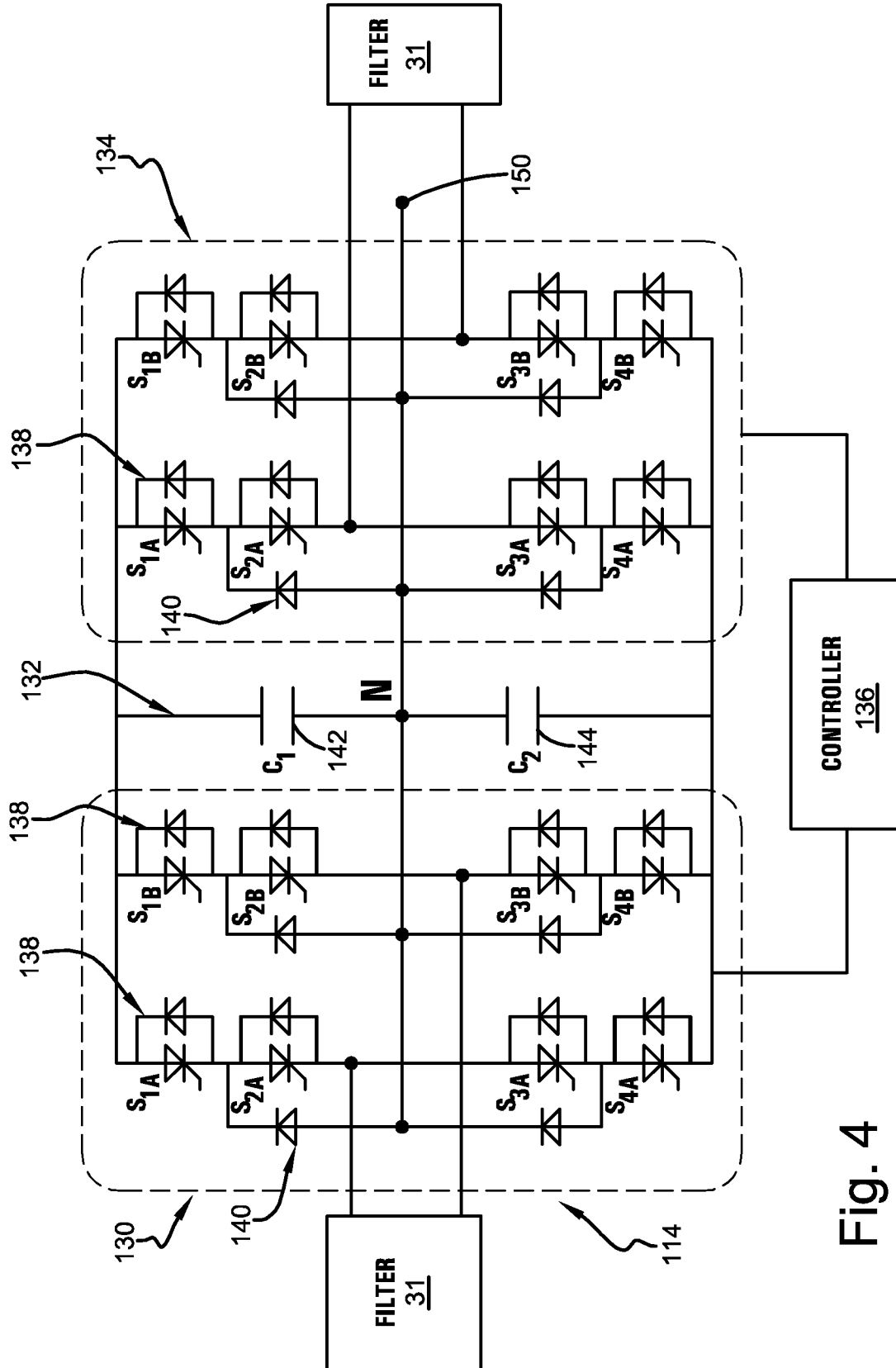

Fig. 4

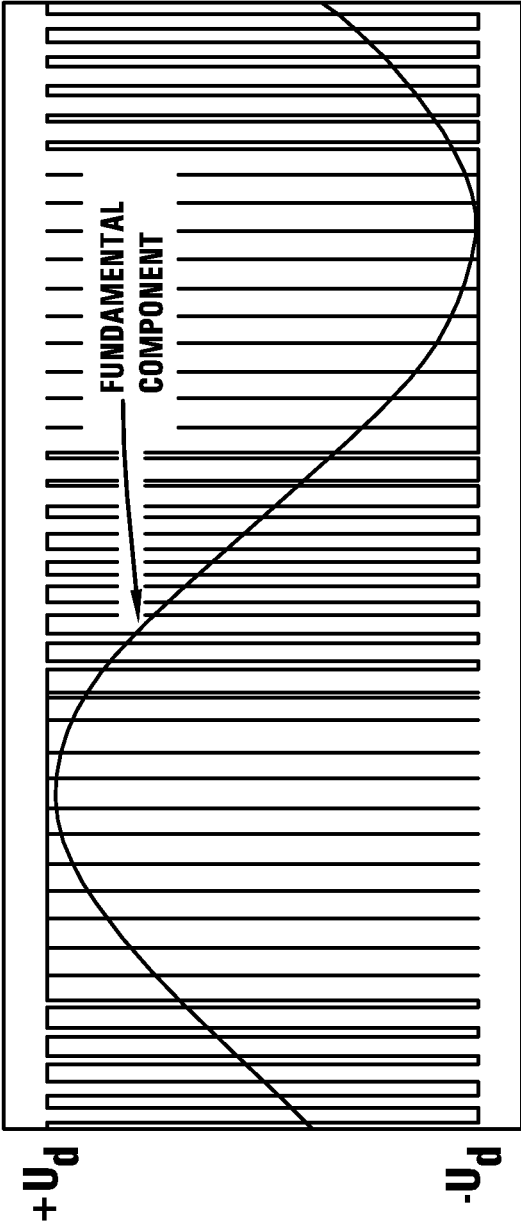

Fig. 5

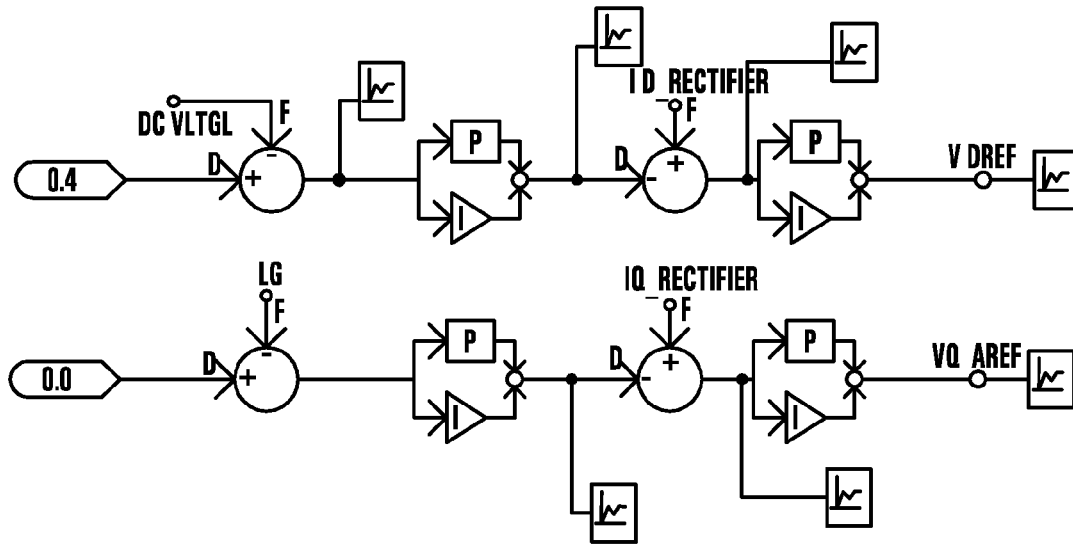

Fig. 8

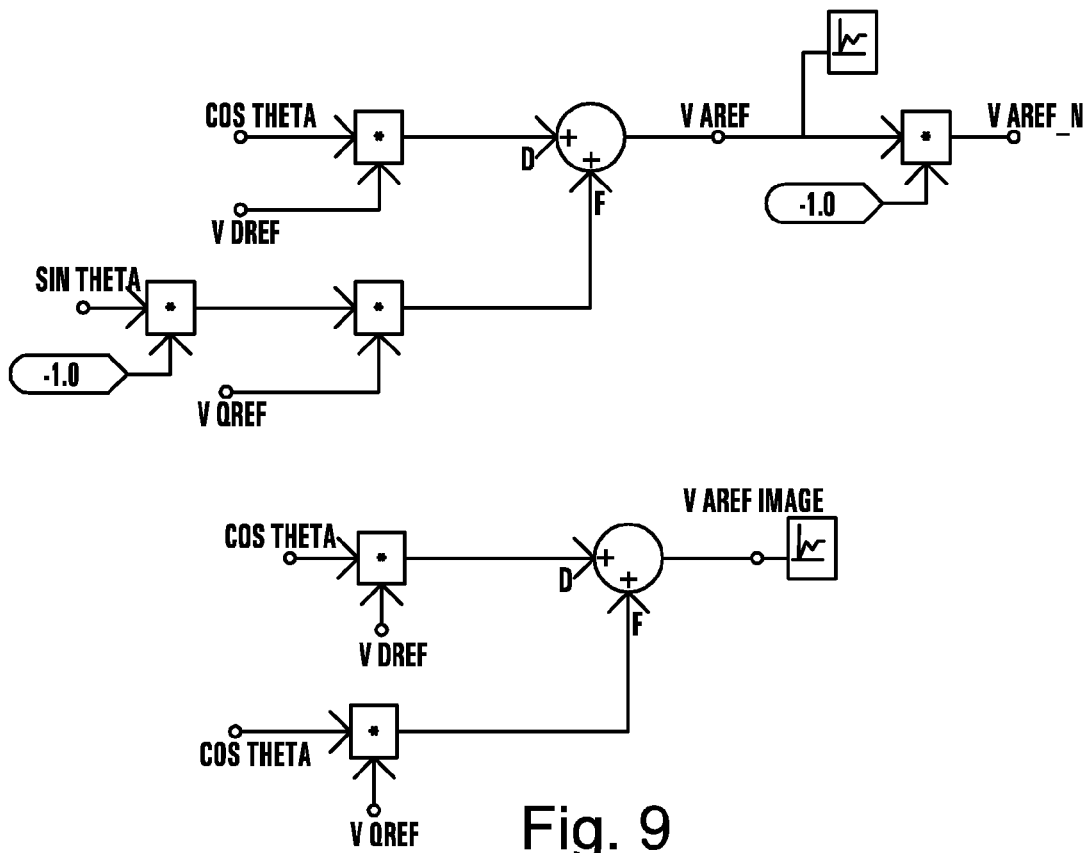

Fig. 9

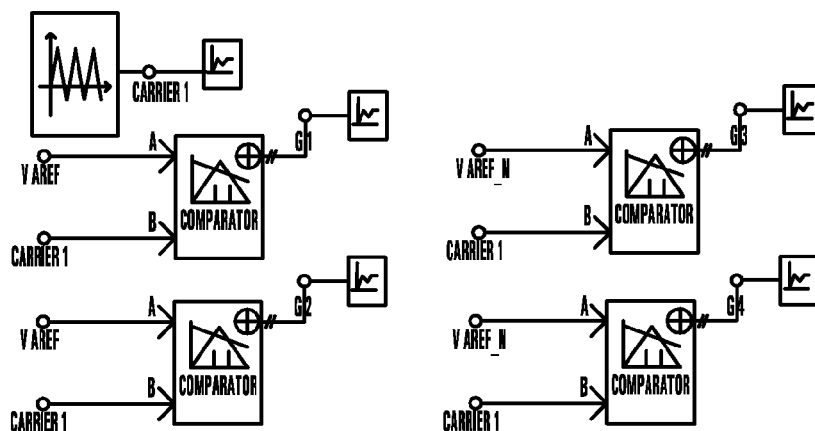

Fig. 10

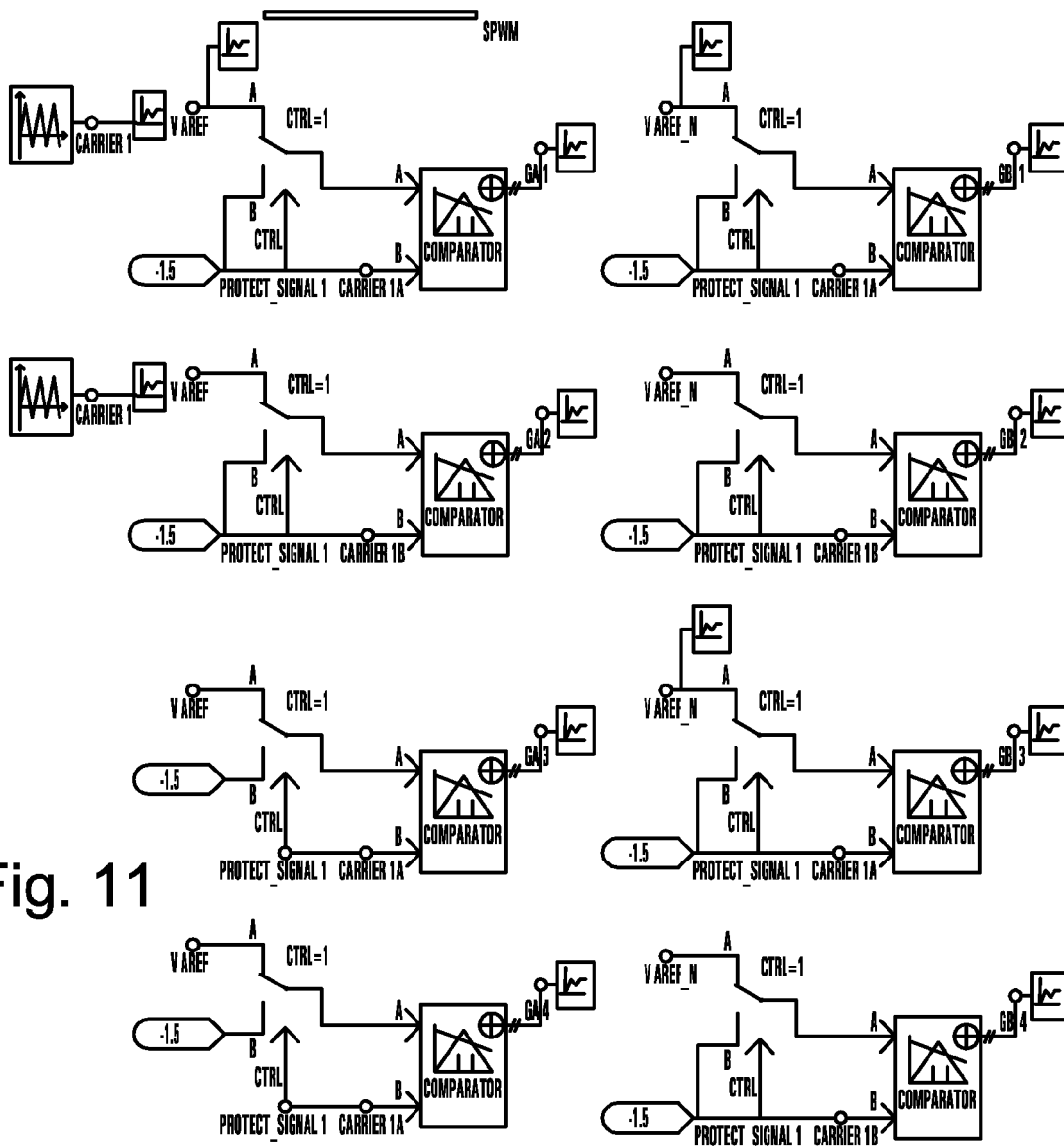

Fig. 11

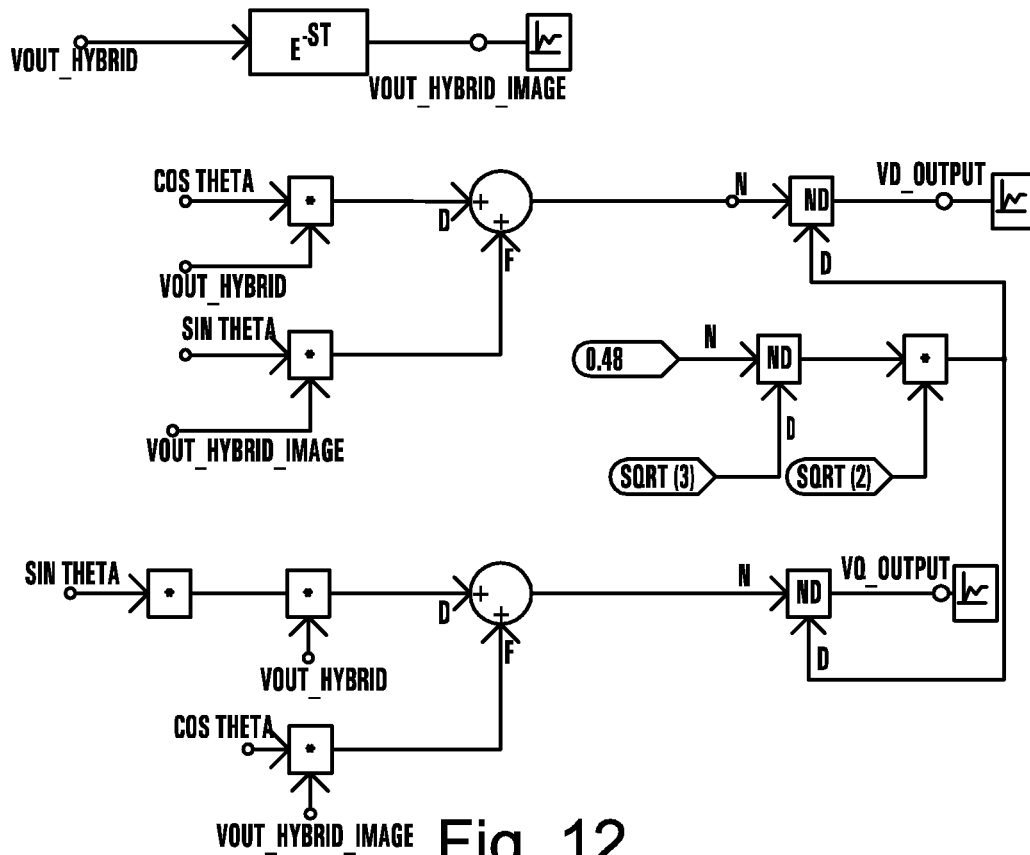

Fig. 12

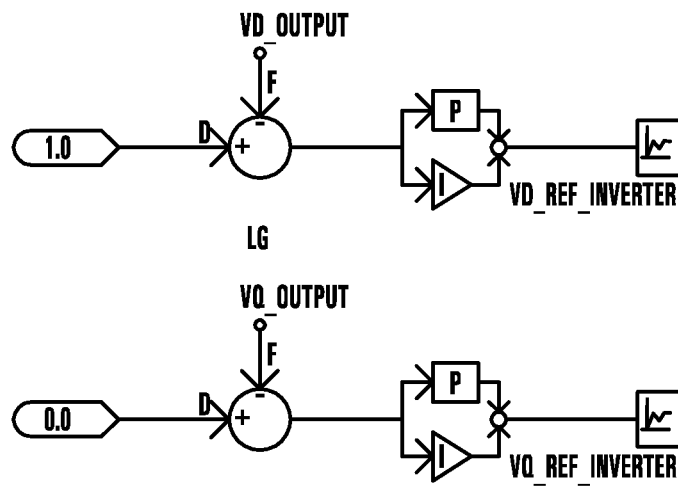

Fig. 13

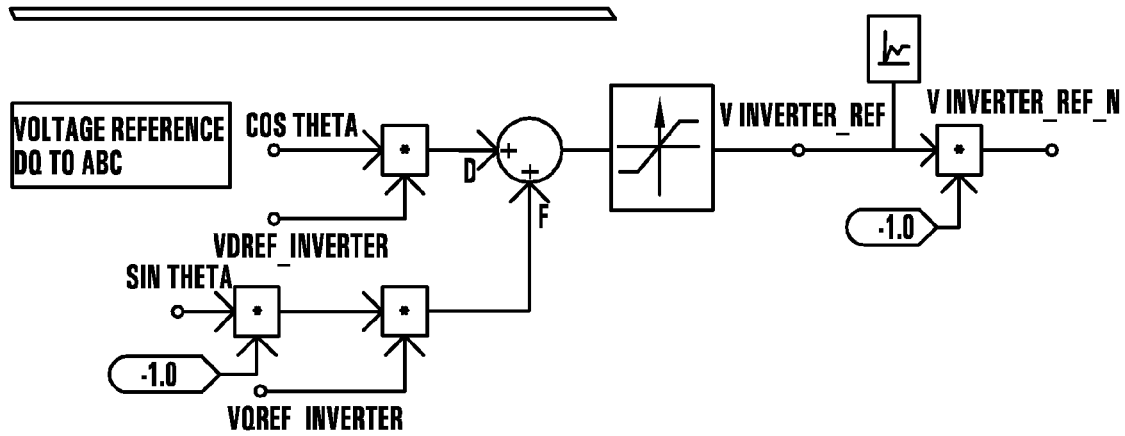

Fig. 14

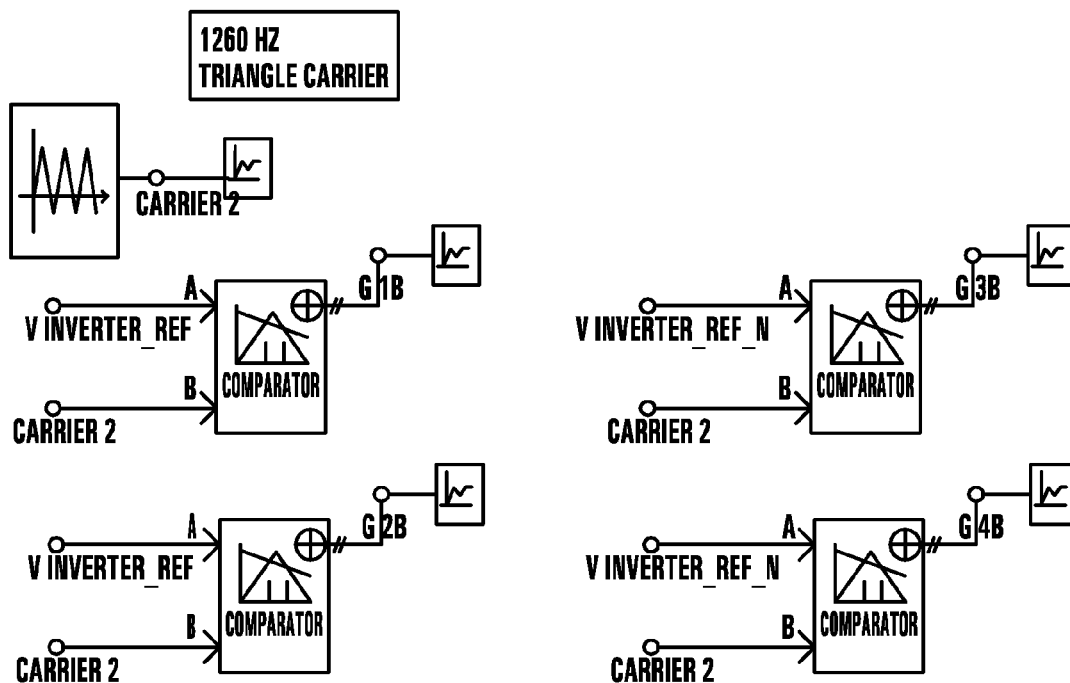

Fig. 15

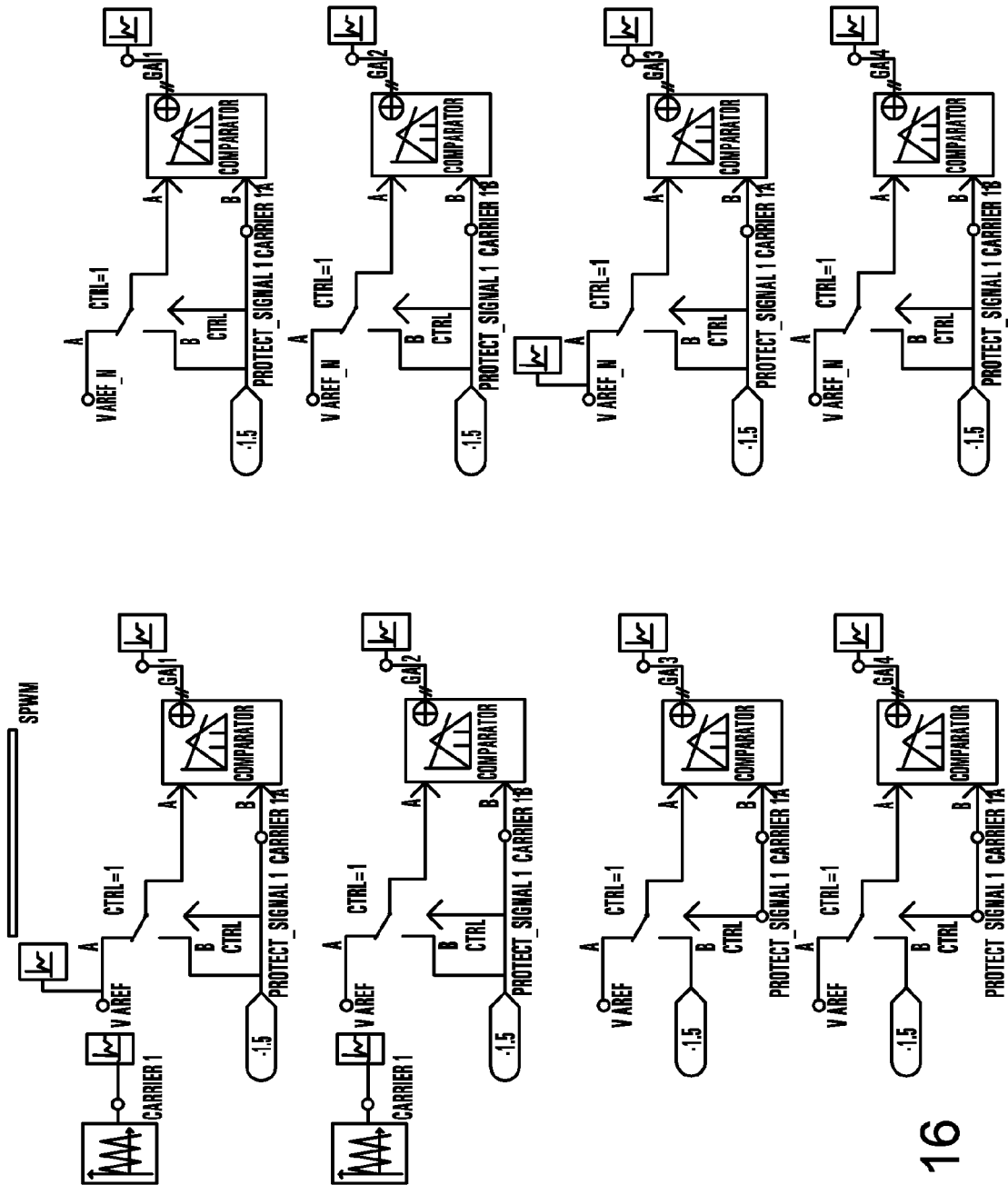

Fig. 16

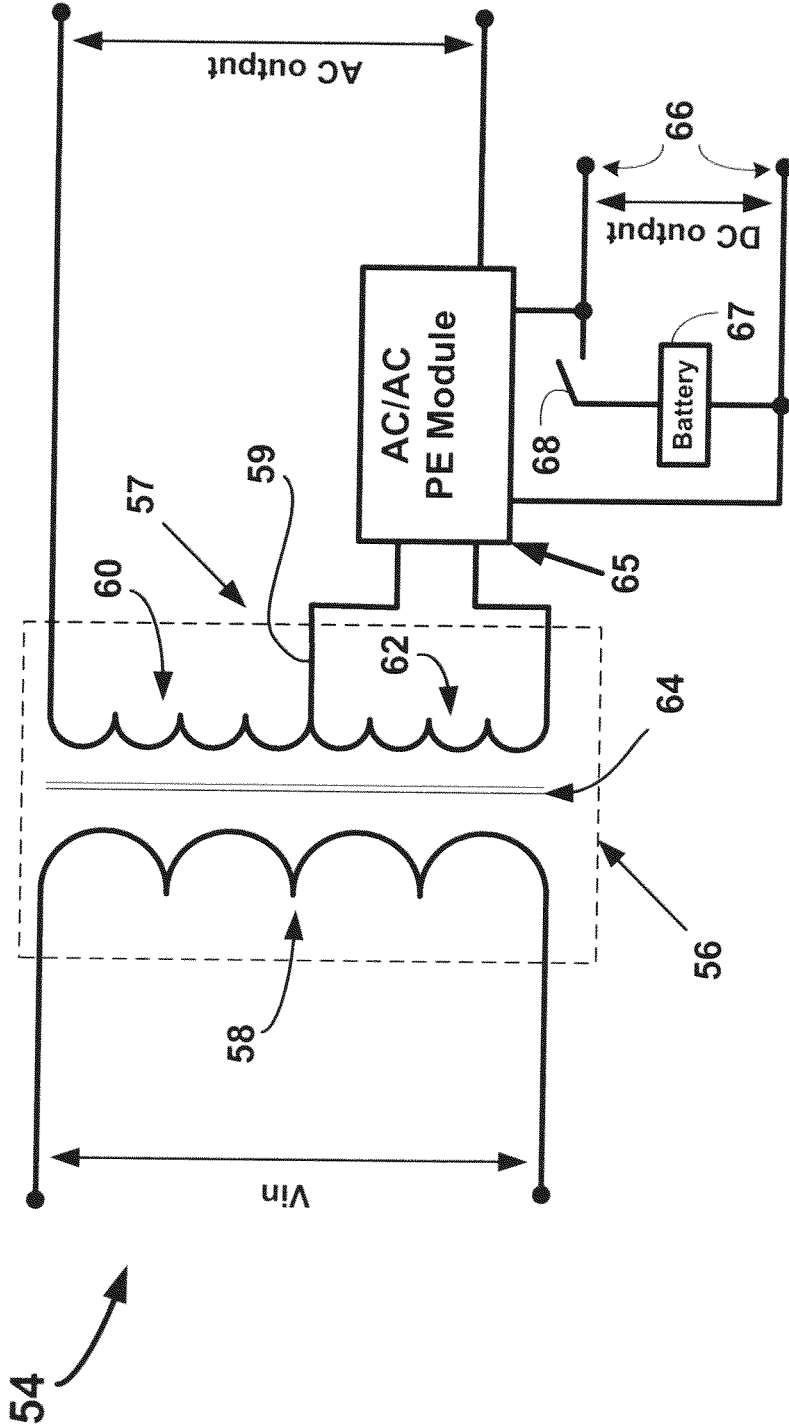

Fig. 17

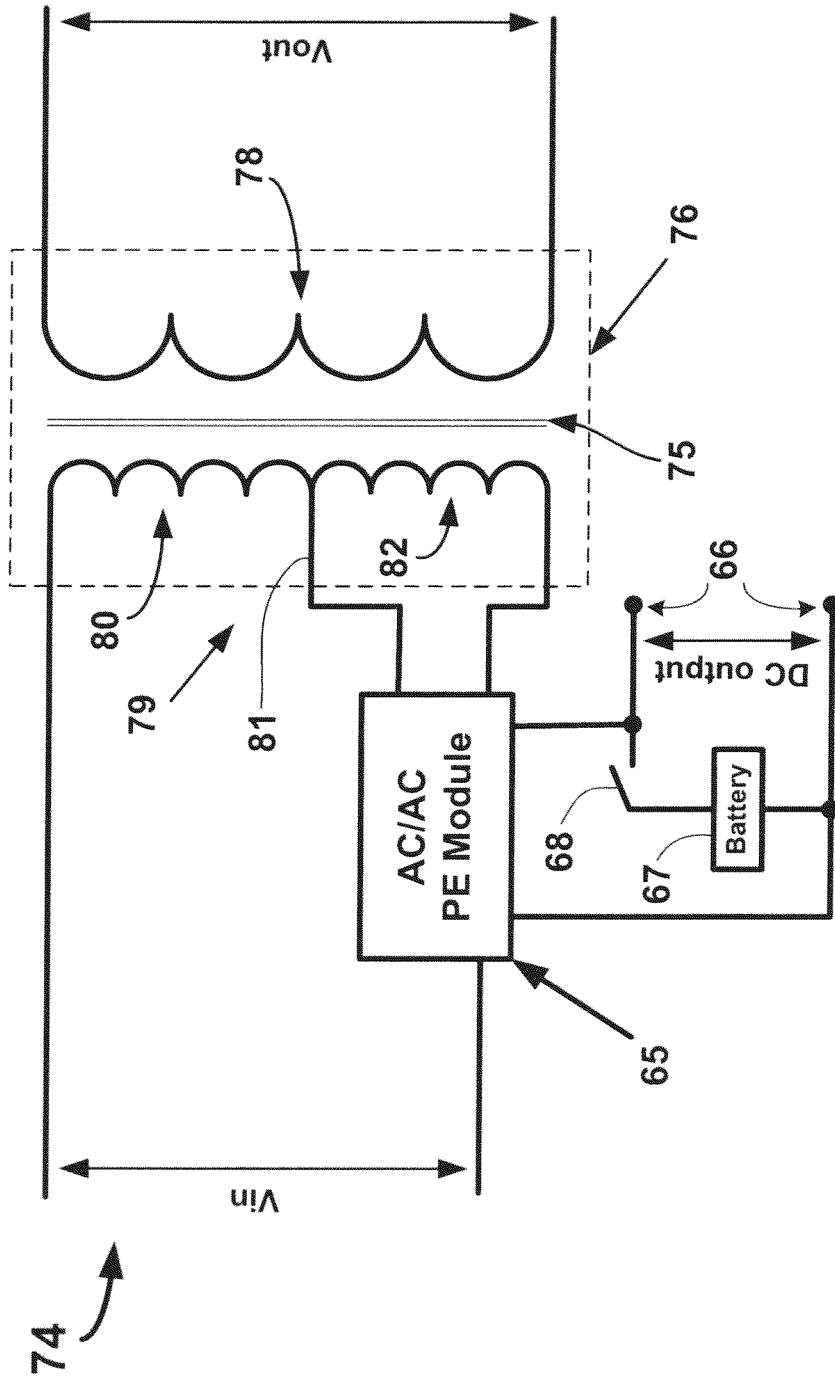

Fig. 18

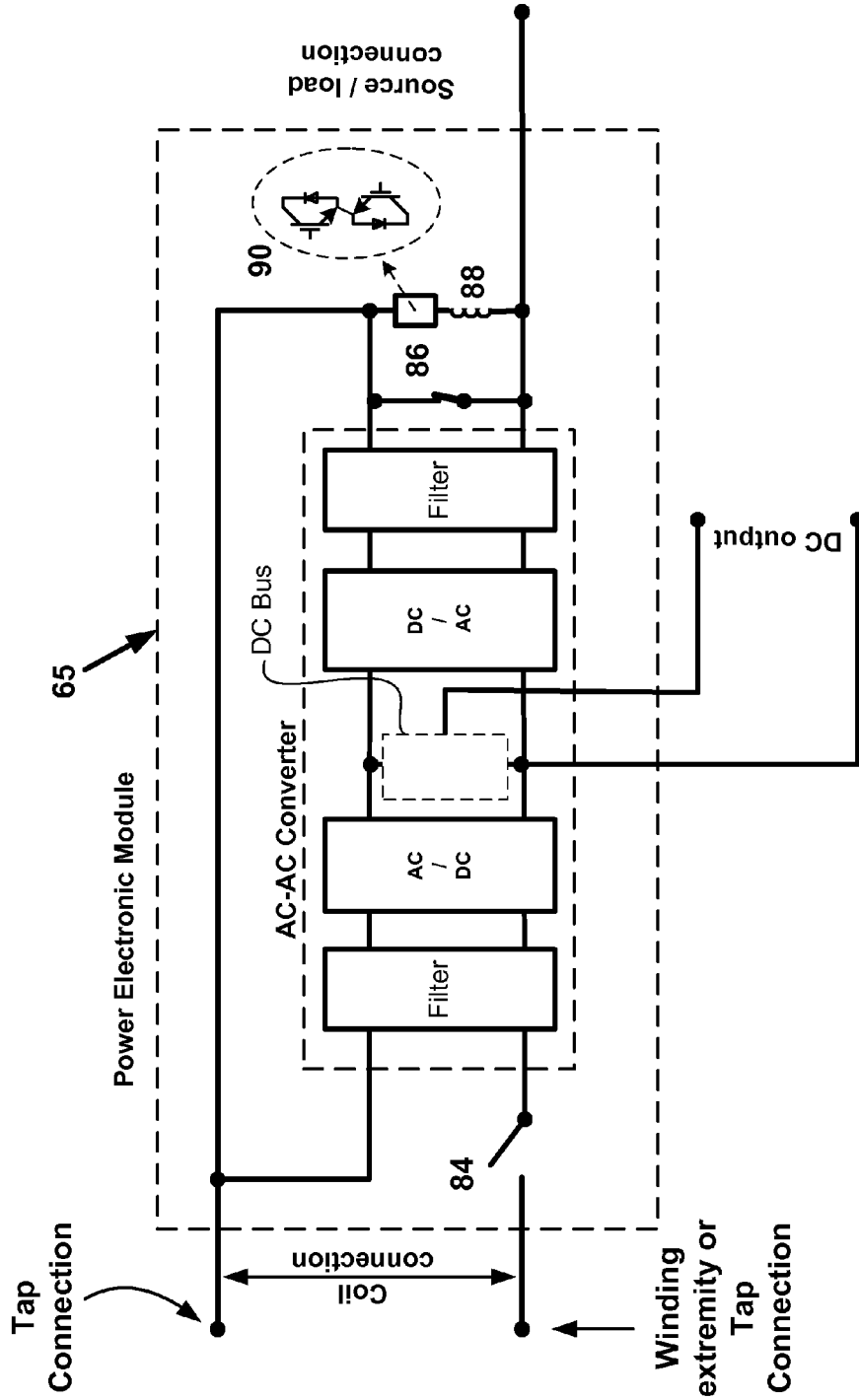

Fig. 19

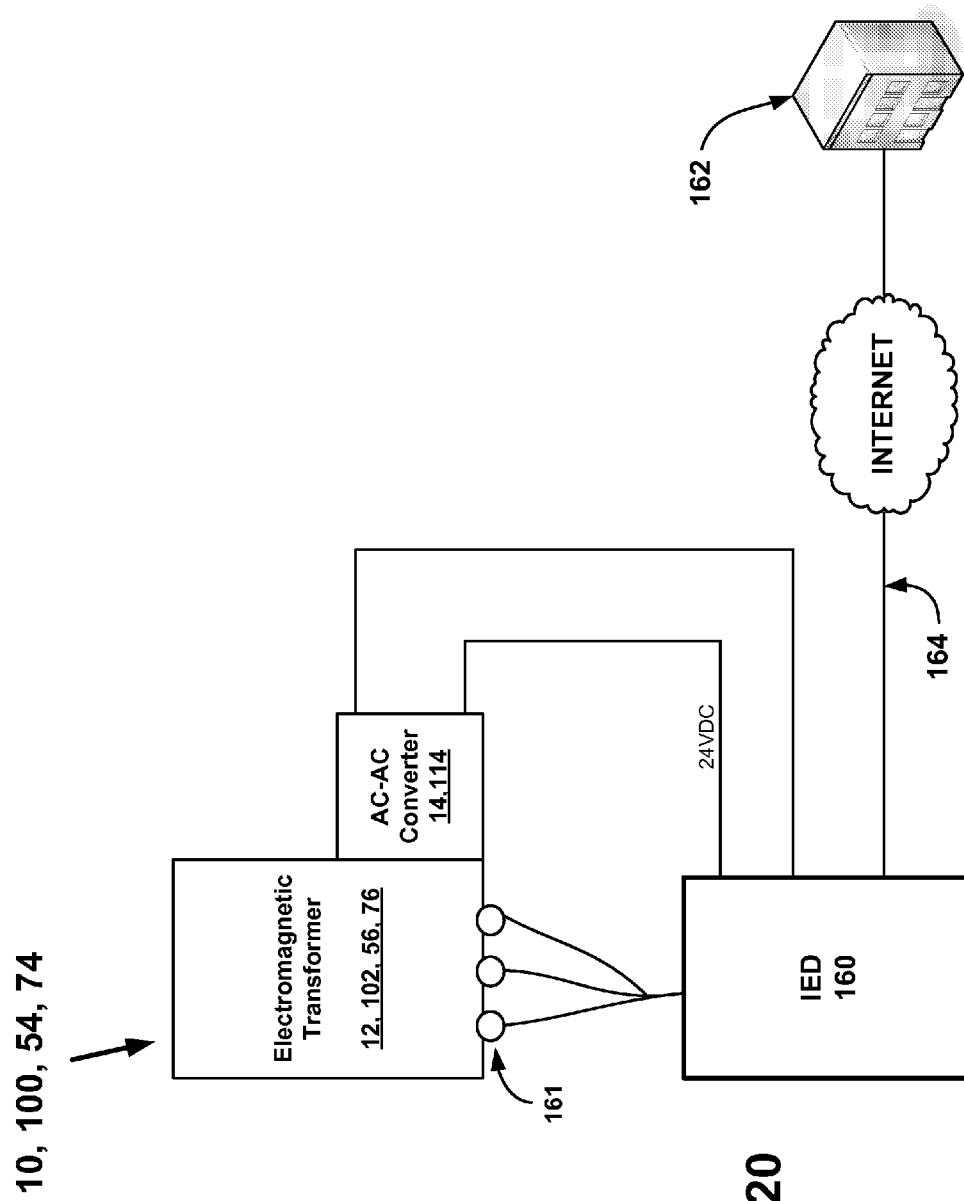

Fig. 20

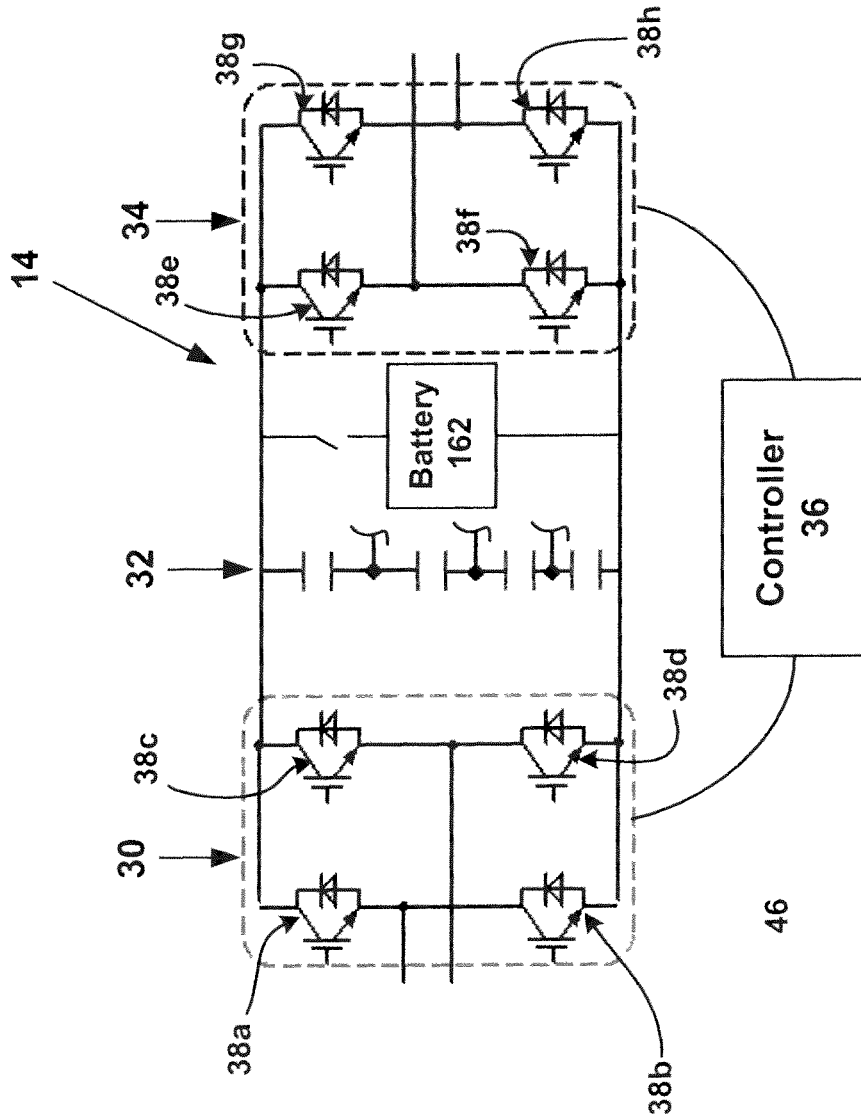

Fig. 21

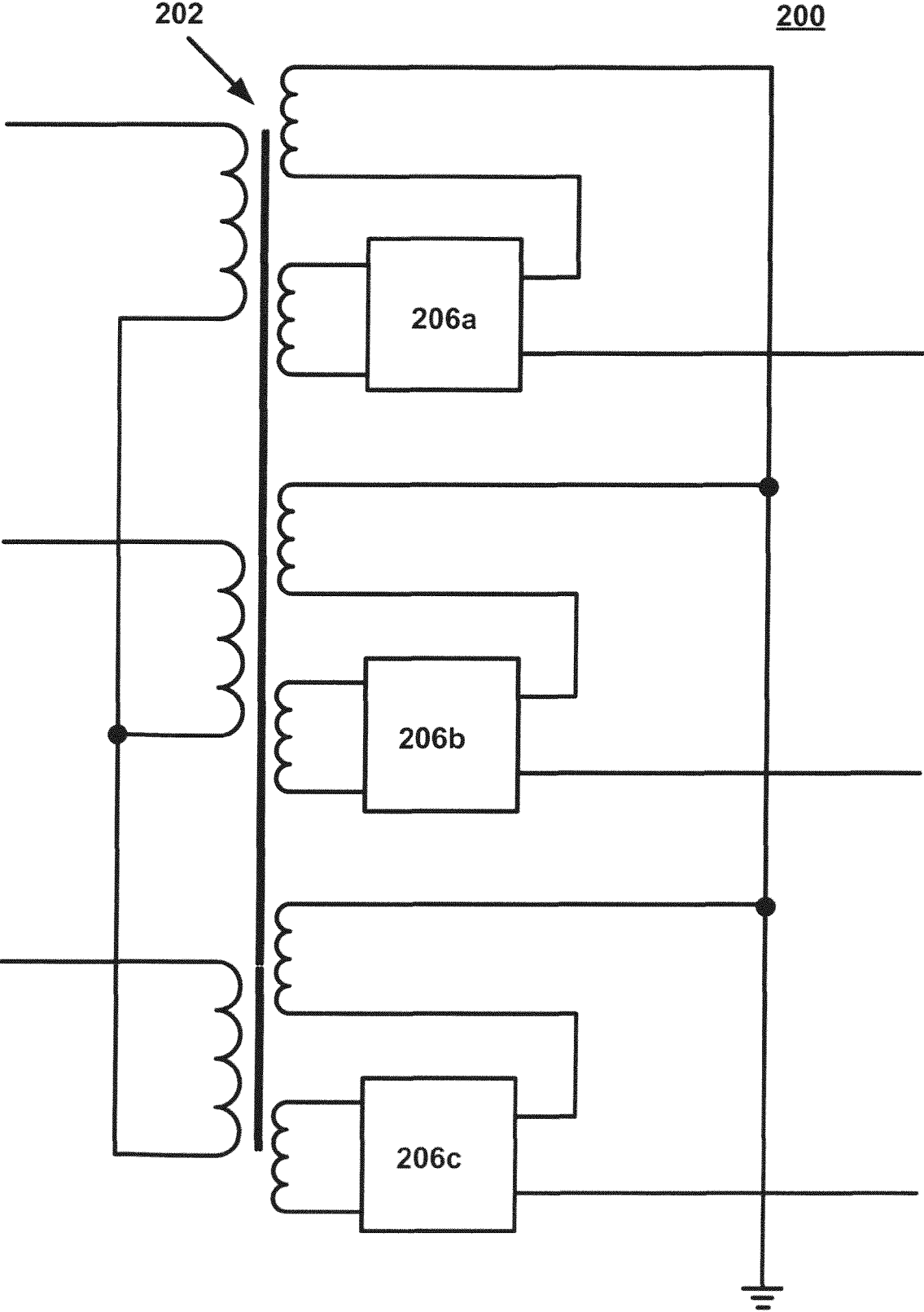

Fig. 22

Transient Voltage Regulation

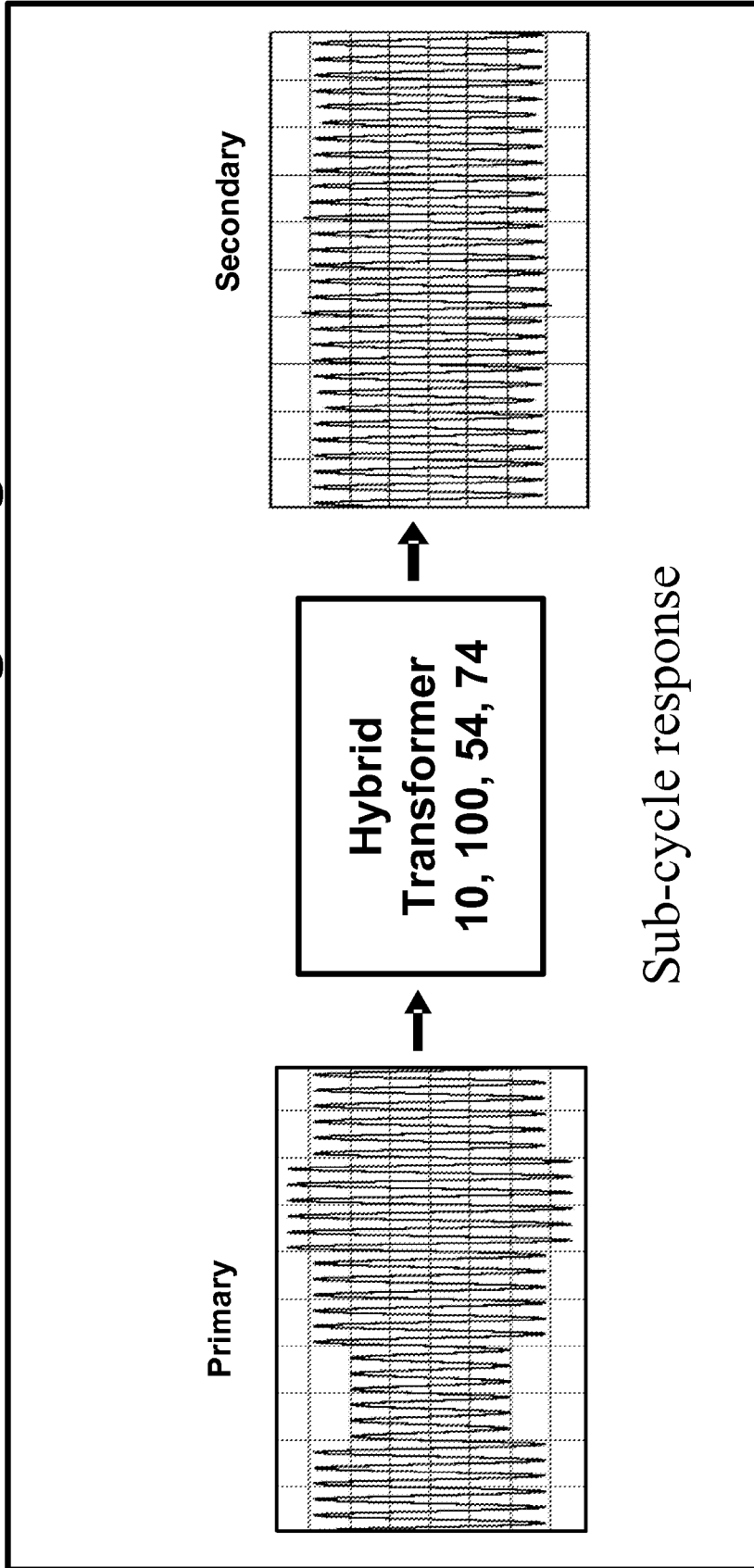

Fig. 23

Long time (sag) Voltage Regulation

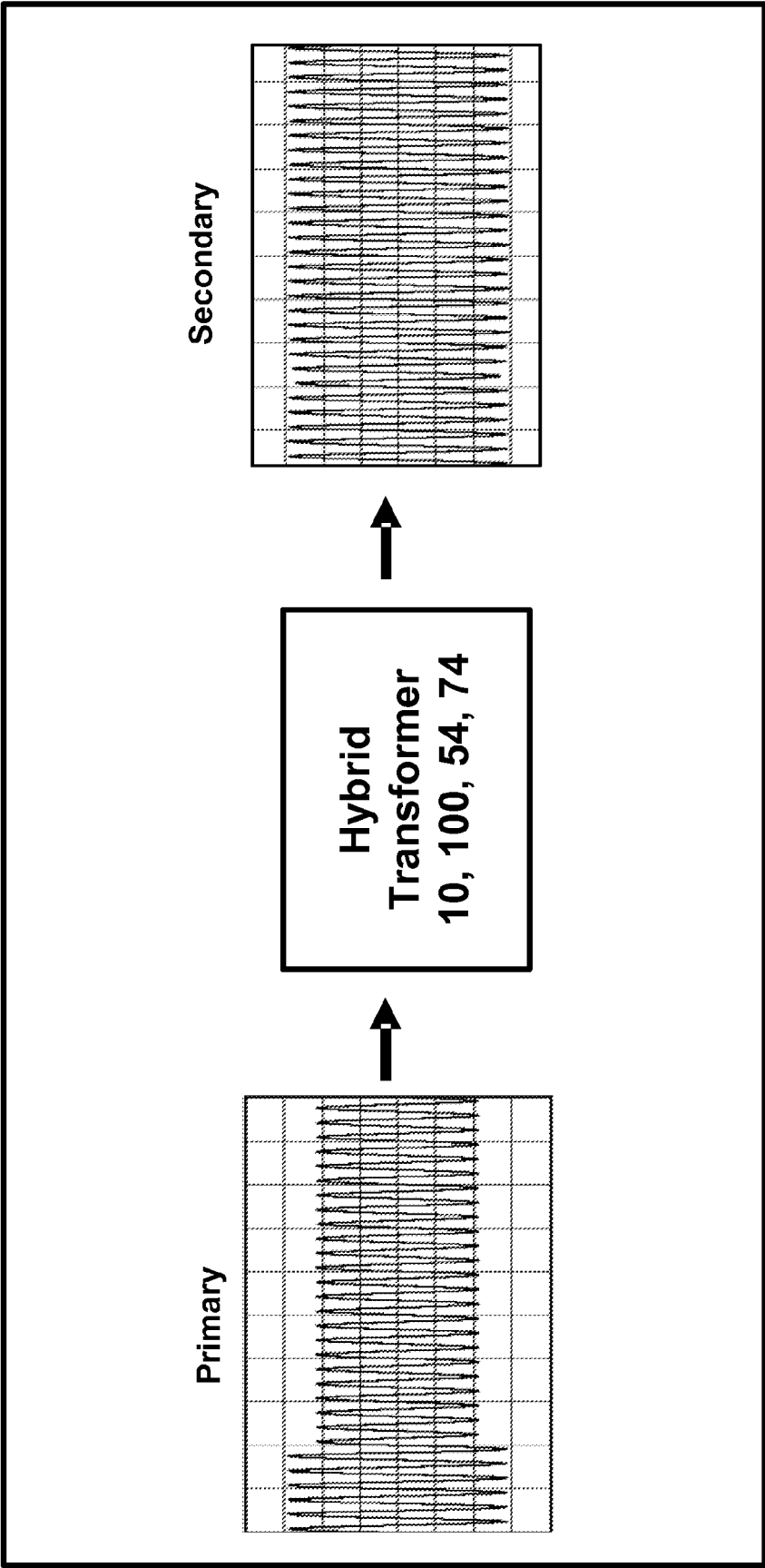

Fig. 24

Power Factor Correction

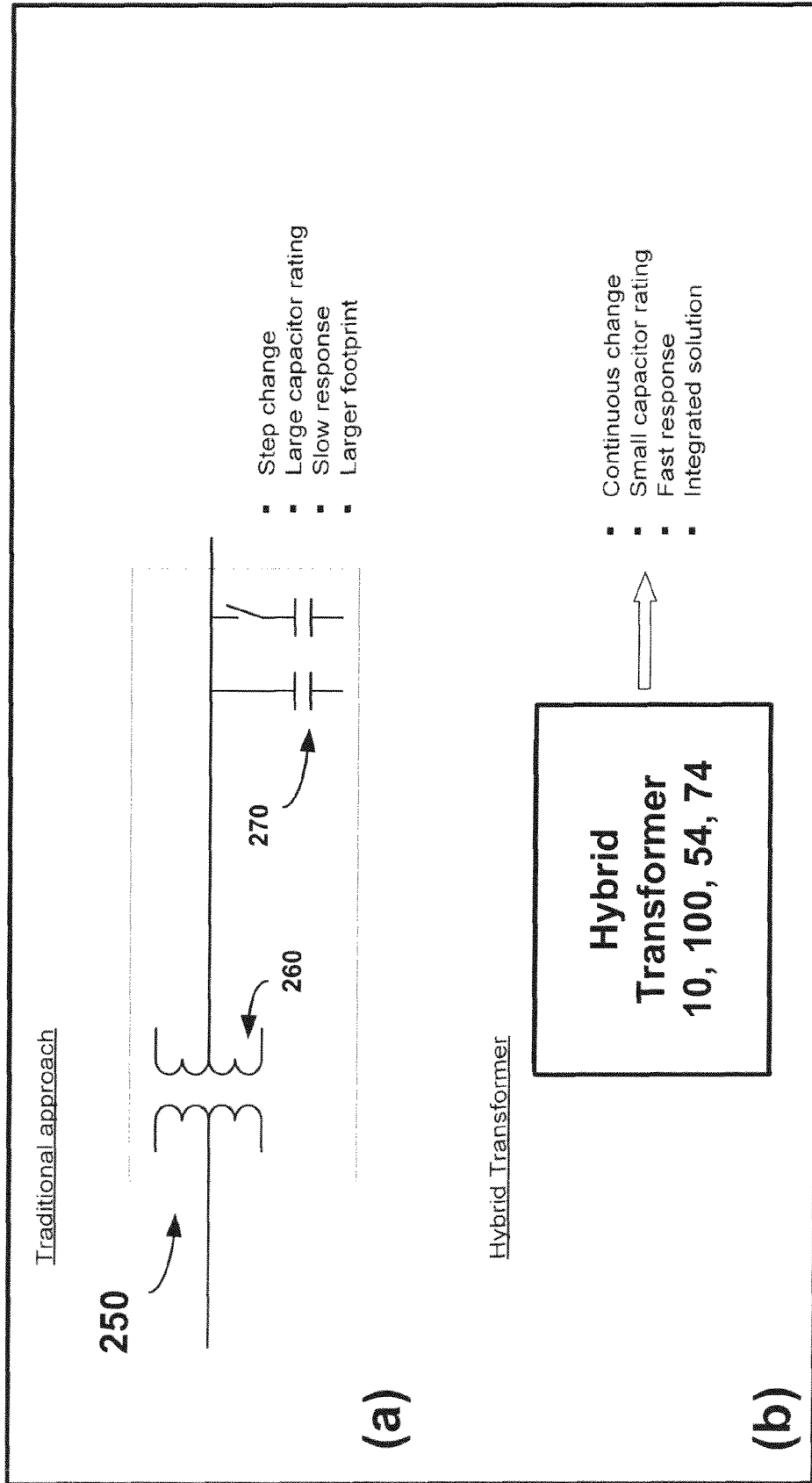

Fig. 25

Phase Shifting Functionality

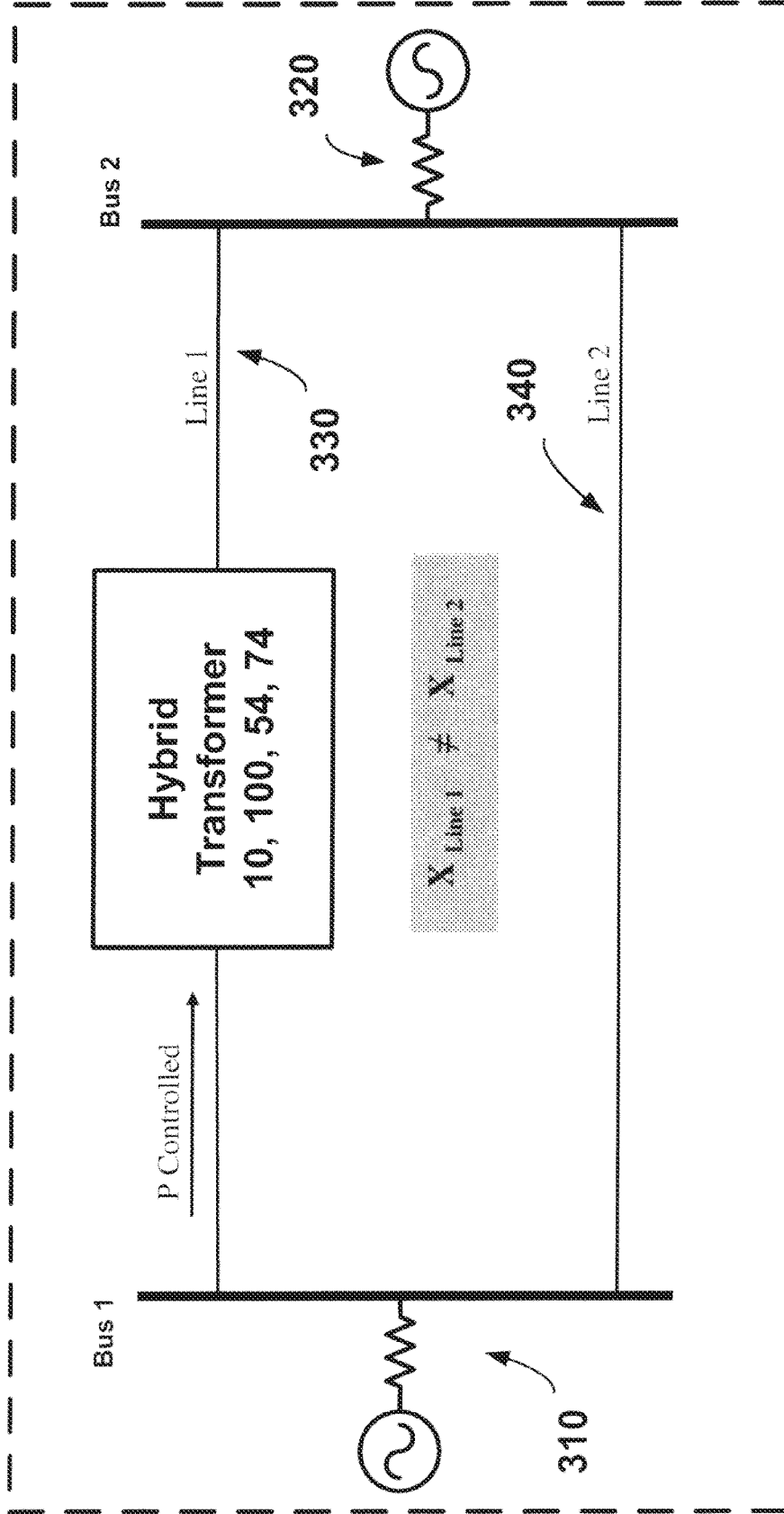

Fig. 26

Datacenter application

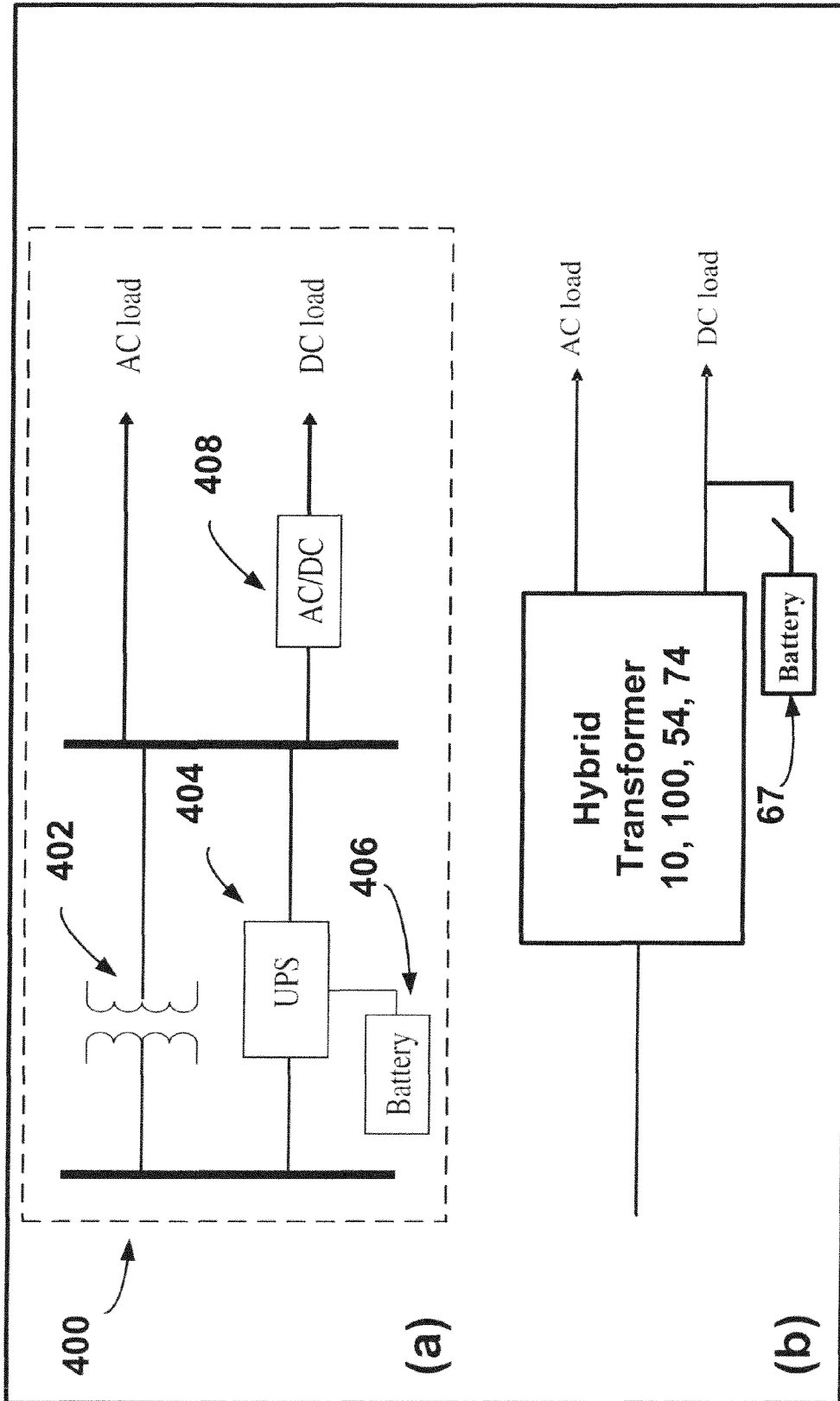

Fig. 27

**HYBRID DISTRIBUTION TRANSFORMER
HAVING A POWER ELECTRONIC MODULE
FOR CONTROLLING INPUT POWER
FACTOR AND OUTPUT VOLTAGE**

CROSS-REFERENCE TO RELATED
APPLICATION

This application claims the benefit of U.S. provisional patent application No. 61/150,591 filed on Feb. 6, 2009 and U.S. provisional patent application No. 61/163,311 filed on Mar. 25, 2009, both of which are hereby incorporated by reference in their entirety.

BACKGROUND OF THE INVENTION

This invention relates to transformers and more particularly to a hybrid distribution transformer utilizing power electronics.

Modern society's movement into the digital age is necessitating the development of a more reliable supply of high-quality electricity. An indispensable component in the supply of electricity to end-users is a distribution transformer. A conventional distribution transformer converts electricity at one voltage to electricity at another voltage, either of higher or lower value. A transformer achieves this voltage conversion using a primary winding and a secondary winding, each of which is wound on a ferromagnetic core and comprises a number of turns of an electrical conductor. A conventional distribution transformer employed in present day power distribution systems cannot protect digital loads against poor power quality, such as sags/swells/distortion. It is estimated that voltage disturbances cost millions of dollars every year to industries around the world.

Sometimes systems are connected to a power distribution line to improve power quality. Examples of such systems include dynamic voltage restorers (DVRs) and static VAR compensators (SVCs). DVRs sustain or restore an operational electric load during sags or spikes in voltage supply, while SVCs provide fast-acting reactive power compensation on power networks. DVRs and SVCs are often "add on" systems that are connected to, and used with, conventional distribution transformers.

More recently, it has been proposed to combine power electronics with a conventional distribution transformer to improve power quality. The present invention is directed to such a transformer.

SUMMARY OF THE INVENTION

In accordance with the present invention, a hybrid transformer is provided. The hybrid transformer has a primary side for receiving an input voltage and current from a source and a secondary side for providing an output voltage and current to a load. The hybrid transformer includes an AC-AC converter, a ferromagnetic core and first, second and third windings wound around the core. At least one of the first, second and third windings is a primary winding for connection to the source, and at least one of the first, second and third windings is a secondary winding for connection to the load. The AC-AC converter includes a first switching bridge connected to the first winding, a second switching bridge connected in series with the second winding and a DC bridge connected between the first and second switching bridges, and a controller. In one aspect, the controller is operable to control the first and second switching bridges to control the power factor on the primary side of the hybrid transformer

and to reduce variations in the output voltage in the event of a change in the input voltage. In another aspect, the controller is operable to control the first switching bridge to control the DC voltage across the DC bridge.

Also provided in accordance with the present invention is another hybrid transformer having a primary side for receiving an input voltage and current from a source and a secondary side for providing output voltage and current to a load. The hybrid transformer includes a ferromagnetic core and first and second windings wound around the core. The first winding has opposing ends, a plurality of turns disposed between the ends and a tap connected to one of the turns. The tap helps define winding portions of the first winding. One of the first and second windings is a primary winding for connection to the source, and the other one of the first and second windings is a secondary winding for connection to the load. A power electronic module is connected to the tap of the first winding. A control device is operable to control the power electronic module to regulate variations in the output voltage and control the power factor on the primary side of the hybrid transformer.

BRIEF DESCRIPTION OF THE DRAWINGS

The features, aspects, and advantages of the present invention will become better understood with regard to the following description, appended claims, and accompanying drawings where:

FIG. 1 shows a schematic circuit of a first hybrid transformer constructed in accordance with a first embodiment of the present invention;

FIG. 2 shows a schematic circuit of a second hybrid transformer constructed in accordance with a second embodiment of the present invention;

FIG. 3 shows a schematic circuit of a first AC-AC converter used in the first hybrid transformer;

FIG. 4 shows a schematic circuit of a second AC-AC converter used in the second hybrid transformer;

FIG. 5 shows a schematic of a sinusoidal waveform formed by pulse width modulation;

FIG. 6 shows a functional block diagram of a phase lock loop;

FIG. 7 shows functional block diagrams for the current α (and a imaginary)-dq transformation;

FIG. 8 shows functional block diagrams for the d-q vector control;

FIG. 9 shows functional block diagrams for the D-Q to a (a imaginary) transformation;

FIG. 10 shows functional block diagrams for the generation of gating signals for the first AC-AC converter;

FIG. 11 shows functional block diagrams for gating signals for the second AC-AC converter;

FIG. 12 shows functional block diagrams for output voltage α -dq transformation;

FIG. 13 shows functional block diagrams for d-q voltage control;

FIG. 14 shows a functional block diagram for d-q reference voltage to abc axis;

FIG. 15 shows SPWM modulation for the first AC-AC

FIG. 16 shows SPWM modulation for the second AC-AC converter;

FIG. 17 shows a schematic circuit of a third hybrid transformer constructed in accordance with a third embodiment of the present invention;

FIG. 18 shows a schematic circuit of a fourth hybrid transformer constructed in accordance with a fourth embodiment of the present invention;

FIG. 19 shows a schematic circuit of a power electronic module used in the third and fourth hybrid transformers shown in FIG. 17 and FIG. 18;

FIG. 20 shows a schematic circuit of a hybrid transformer with an IED and a communication link;

FIG. 21 shows a schematic circuit of the first AC-AC converter with a battery bank;

FIG. 22 shows a schematic circuit of a three-phase hybrid transformer constructed in accordance with the present invention;

FIG. 23 shows a plot of the transient voltage regulation capability of a simulated hybrid transformer of the present invention;

FIG. 24 shows a plot of the long time (sag) voltage regulation capability of a simulated hybrid transformer of the present invention;

FIG. 25 shows an application of a hybrid transformer of the present invention for power factor correction;

FIG. 26 shows an application of a hybrid transformer of the present invention for phase shifting and power-flow control on parallel lines; and

FIG. 27 shows an application of a hybrid transformer of the present invention for a datacenter where AC and DC loads are powered by the hybrid transformer.

DETAILED DESCRIPTION OF ILLUSTRATIVE EMBODIMENTS

It should be noted that in the detailed description that follows, identical components have the same reference numerals, regardless of whether they are shown in different embodiments of the present invention. It should also be noted that in order to clearly and concisely disclose the present invention, the drawings may not necessarily be to scale and certain features of the invention may be shown in somewhat schematic form.

The present invention is directed to a hybrid transformer that may be used in the distribution of power. The hybrid transformer generally includes an electromagnetic transformer and a power electronic AC-AC converter. The electromagnetic transformer includes a ferromagnetic core, a primary winding structure and a secondary winding structure, each of which are wound on the ferromagnetic core. The primary winding structure comprises one or more primary windings and the secondary winding structure comprises one or more secondary windings. The electromagnetic transformer may be a liquid-filled transformer, wherein the core and the primary and secondary winding structures are immersed in a dielectric fluid, or the electromagnetic transformer may be a dry type transformer, wherein the core and the primary and secondary winding structures are not immersed in a dielectric fluid, but, instead, are encased in a dielectric resin or surrounded by an inert gas, or simply ambient air. The hybrid transformer may be a single phase transformer, a three phase transformer, or a multiphase (>3 phases) transformer. The hybrid transformer may be pole-mounted or pad-mounted.

Two embodiments of a hybrid transformer constructed in accordance with the present invention are shown in FIGS. 1 and 2 and are designated by the reference numerals 10, 100, respectively. The hybrid transformer 10, 100 includes an electromagnetic transformer 12, 102 integrated with an AC-AC converter 14, 114. The electromagnetic transformer 12, 102 includes a ferromagnetic core 16 and at least three windings. For example: one primary winding and two secondary windings, or two primary windings and one secondary winding. The hybrid transformer 10, 100 may be a single

phase transformer that has a power rating of about 67 kVA and a voltage rating of about 7.97 kV to 277 V.

The AC-AC converter 14, 114 can be connected into the primary winding structure or the secondary winding structure. If the AC-AC converter 14, 114 is connected into the primary winding structure, the primary winding structure comprises at least two primary windings and if the AC-AC converter 14, 114 is connected into the secondary winding structure, the secondary winding structure comprises at least two secondary windings. The winding on a side (primary or secondary) whose ends are connected to the AC-AC converter 14, 114 shall be referred to as a proximate winding and the other winding(s) on the side shall be referred as distal winding(s).

As shown in FIG. 1, the hybrid transformer 10 includes the electromagnetic transformer 12, which has a primary winding structure 18 with a single primary winding 20 and a secondary winding structure 22 with two secondary windings 24, 26. The AC-AC converter 14 is connected to ends of the secondary winding 26 and is connected in series with the secondary winding 24. The voltage V_{out} across the secondary winding structure is equal to the voltage V_{out1} across the secondary winding 24 plus the voltage V_{out2} across the AC-AC converter 14. Under normal operating conditions, the secondary winding 24 produces 100% of the output voltage to the load. When required, the secondary winding 26 can produce up to 20% of the output voltage to the load. The hybrid transformer 10 may be constructed such that the primary winding 20 can support a voltage of 8.66 kV, the secondary winding 24 can produce a voltage of 277 V and the secondary winding 26 can produce a voltage of 55.4 V, which corresponds to 20% of the voltage of winding 24.

As shown in FIG. 2, the hybrid transformer 100 includes the electromagnetic transformer 102, which has a primary winding structure 104 with two primary windings 106, 108 and a secondary winding structure 112 with a single secondary winding 116. The AC-AC converter 114 is connected to ends of the primary winding 108 and is connected in series with the primary winding 106. The voltage V_{in} across the primary winding structure is equal to the voltage V_{in1} across the primary winding 106 plus the voltage V_{in2} across the AC-AC converter 114. The primary winding structure 104 is constructed such that, under normal conditions, the primary winding 106 supports 100% of the input voltage. When required, the primary winding 108 can support about 20% of the input voltage. The hybrid transformer 100 may be constructed such that the primary winding 106 can support a voltage of 7.97 kV, the primary winding 108 can support a voltage of 1.59 kV, the secondary winding 116 can provide a voltage of 277 V and there is a leakage reactance of 0.1 pu. Since the input voltage equals the voltage output from the AC-AC converter 114 plus the voltage of the primary winding 106, control of the voltage output from the AC-AC converter 114 controls the input voltage and, thus, the output voltage.

The AC-AC converter 14 may be an AC-DC-AC converter having the structure shown in FIG. 3. In this embodiment, the AC-AC converter 14 includes a first switching bridge 30 connected by a DC link or bridge 32 to a second switching bridge 34. The first switching bridge 30 is connected to the ends of the secondary winding 26. A filter 31 may be connected between the first switching bridge 30 and the secondary winding 26. Another filter 31 may also be connected to an output of the second switching bridge 34. Each of the first and second switching bridges 30, 34 is connected to and controlled by a controller 36. In addition,

5

each of the first and second switching bridges **30**, **34** comprises a plurality of switching devices **38**. As shown in FIG. **3**, each of the first and second switching bridges **30**, **34** may comprise a pair of arms connected in parallel, with each arm having a pair switching devices **38** connected in series. Each switching device **38** may be an insulated gate bipolar transistor (IGBT) and an anti-parallel diode. The DC bridge **32** may comprise a plurality of capacitors connected in series. The capacitors may have the same or different capacitances. As shown in FIG. **3**, the DC bridge **32** may have four capacitors **40**, **42**, **44**, **46**. A plurality of DC taps are connected to the DC bridge **32** and provide different maintained DC voltage levels. More specifically, three DC taps **48**, **50**, **52** may be connected between pairs of the capacitors **40**, **42**, **44**, **46**, respectively, and may have maintained voltages of 12 Volts, 24 Volts and 100 Volts. Combinations of these taps **48**, **50**, **52** can be used to obtain 36, 112, 123 and 136 Volts DC. Other voltage levels can be implemented as well.

The AC-AC converter **114** may be an AC-DC-AC converter having the structure shown in FIG. **4**. In this embodiment, the AC-AC converter **114** is a neutral point converter (NPC) having three levels. The AC-AC converter **114** includes a first switching bridge **130** connected by a DC link or bridge **132** to a second switching bridge **134**. The first switching bridge **130** is connected to the voltage source. A filter **31** may be connected between the first switching bridge **130** and the voltage source. Another filter **31** may be connected between the second switching bridge **134** and the primary winding **108**. Each of the first and second switching bridges **130**, **134** is connected to and controlled by a controller **136**. In addition, each of the first and second switching bridges **30**, **34** comprises a plurality of switching devices **138**. As shown in FIG. **4**, each of the first and second switching bridges **130**, **134** may comprise a pair of arms connected in parallel, with each arm having four switching devices **138** connected in series. In each arm, a clamping diode **140** is connected between a top pair of the switching devices **138** and a bottom pair of the switching devices **138**. Each switching device **138** may be an insulated gate bipolar transistor (IGBT) and an anti-parallel diode. The DC bridge **132** may comprise a plurality of capacitors connected in series. As shown in FIG. **4**, the DC bridge **132** may have two capacitors **142**, **144**. The clamping diodes **140** are connected (clamped) to the DC bridge **132**, between the capacitors **142**, **144**, i.e., at the middle or neutral point, where the voltage is half of the voltage across the entire DC bridge **132**. A tap **150** may be connected to the neutral point as well.

As shown in FIG. **3**, each filter **31** comprises inductors **147** connected into lines **151**, **153**, respectively. A capacitor **149** is connected in parallel between the lines **151**, **153**. The filters **31** help prevent high frequency harmonics from being introduced into the output voltage of the transformer **10**, **100** and the currents in the primary and secondary windings as a result of the switching of the switching devices **38**, **138**. Although the filters **31** are shown as being an LC filter, it should be appreciated that other types of filters may be used. For example, an L or an LCL filter may be used.

Although the AC-AC converters **14**, **114** are shown having different constructions or topologies, it should be appreciated that they may both have the same topology, which may be the topology described above for the AC-AC converter **14**, or the topology described above for the AC-AC converter **114**. It should further be appreciated that other AC-AC converter topologies may be utilized for both of the AC-AC converters **14**, **114**, provided the other topologies have a DC link or bridge. For example, NPC AC-AC

6

converters may be used having four, five, etc. levels. For those applications that do not require DC outputs, an AC-AC converter without a DC bridge can be used.

The controllers **36** and **136** each include a processor for executing a program stored in associated memory. The controllers **36** and **136** control the AC-AC converters **14**, **114**, respectively, using pulse width modulation (PWM), wherein the switching devices **38**, **138** are opened and closed to create a series of voltage pulses, wherein the average voltage is the peak voltage times the duty cycle, i.e., the "on" and "off" times of pulses. In this manner, a sine wave can be approximated using a series of variable-width positive and negative voltage pulses as shown in FIG. **5**. The phase and the amplitude of the sine wave can be changed by changing the PWM pattern.

In each of the AC-AC converters **14**, **114**, the controller **36**, **136** controls the first switching bridge **30**, **130** to balance the real power transferring from the AC-AC converter **14**, **114** and to control the primary side power factor by providing reactive power to the load through the transformer coupling. The controller **36**, **136** controls the first switching bridge **30**, **130** based on the d-q transformation, which is a transformation of coordinates from the three-phase stationary coordinate system to a dq rotating coordinate system. This transformation is typically made in two steps: 1) a transformation from the three-phase stationary coordinate system to the two-phase, so-called ab, stationary coordinate system and 2) a transformation from the ab stationary coordinate system to the dq rotating coordinate system. A phase lock loop, such as shown in FIG. **6**, may be used to extract the phase angle of the primary side voltage. The d-q transform for a single phase converter is similar to that for a three-phase system. However, because there is only one phase variable, the corresponding imaginary variable which is 90 degree lagging the real signal has to be hypothesized. Real signal $X_R = X_M \cos(\omega t + \phi)$
Imaginary variable: $X_I = X_M \sin(\omega t + \phi)$

Applying a rotating transformation matrix T to the stationary real and imaginary variables:

$$T = \begin{bmatrix} \cos(\omega t) & \sin(\omega t) \\ -\sin(\omega t) & \cos(\omega t) \end{bmatrix}$$

The variables in D-Q rotating coordinates become:

$$\begin{bmatrix} X_D \\ X_q \end{bmatrix} = T \begin{bmatrix} X_R \\ X_I \end{bmatrix} = X_M \begin{bmatrix} \cos(\phi) \\ \sin(\phi) \end{bmatrix}$$

The inverse transformation matrix from the dq rotating coordinates to the stationary real and imaginary variables is:

$$T^{-1} = T^T = \begin{bmatrix} \cos(\omega t) & -\sin(\omega t) \\ \sin(\omega t) & \cos(\omega t) \end{bmatrix}$$

Functional block diagrams for the current a (and a imaginary)-dq transformation is shown in FIG. **7**. In FIGS. **7** and **8**, the term "rectifier" refers to the DC bridge **32**, **132**. The controller **36**, **136** controls the voltage across the DC bridge **32**, **132** to follow a reference DC voltage to balance the real power. The reference DC voltage is selected so that the AC-AC converter can compensate for up to a predetermined

amount of voltage swell and sag, such as a voltage swell of up to 15% of the normal input voltage and a voltage sag of up to 35% of the normal input voltage. In the first example embodiment of the hybrid transformer **10**, the reference DC voltage is 0.5 kV, whereas in the first example embodiment of the hybrid transformer **100**, the reference DC voltage is 4.5 kV. In addition, the controller **36**, **136** controls the q-axis component of the primary side current to be zero, which means unity power factor of the input to the hybrid transformer **10**, **100**. Functional block diagrams for the d-q vector control is shown in FIG. **8**. First in the d-axis loop, the DC link (DC bridge **32**, **132**) voltage is compared with the reference DC voltage and the difference is fed to a proportional integral (PI) regulator, which generates I_{d_ref} . The I_d of the rectifier (DC bridge **32**, **132**) is then compared with I_{d_ref} and the difference is fed to another PI regulator to generate the V_{d_ref} . In the q-axis loop, the I_q of the source current is compared to 0 and the difference is fed to a PI regulator, which generates the I_{q_ref} for the rectifier in the secondary side. Then, $I_{q_rectifier}$ is compared with I_{q_ref} and the difference is fed to another PI regulator to generate the V_{q_ref} . The d-q voltages, V_{dref} and V_{qref} , are transformed to A and a-imaginary axis to generate the modulation signal for sinusoidal PWM (SPWM). Then gating signals are sent to the switching devices of the first switching bridge **30**, **130**. Functional block diagrams for the D-Q to a (a imaginary) transformation are shown in FIG. **9**. Functional block diagrams for the generation of the gating signals for the AC-AC converter **14** are shown in FIG. **10** and functional block diagrams for the gating signals for the AC-AC converter **114** are shown in FIG. **11**.

In each of the AC-AC converters **14**, **114**, the controller **36**, **136** controls the second switching bridge **34**, **134** to maintain the output voltage at a set value or reference output voltage (such as $480V/\sqrt{3}$ RMS) and to be a clean sinusoidal waveform. Thus, in the event of a voltage sag, the controller **36**, **136** increases the voltage output of the AC-AC converter **14**, **114** and in the event of a voltage swell, the controller decreases the voltage output of the AC-AC converter **14**, **114**. In order to fully utilize the secondary winding **24** and avoid circulation current, the controller **36** controls the output voltage of the AC-AC converter **14** to be in phase with the voltage of the secondary winding **24**. Similarly, in order to fully utilize the input voltage and avoid circulation current, the controller **136** controls the output voltage of the AC-AC converter **114** to be in phase with the voltage of the primary winding **106**.

The controller **36**, **136** also controls the second switching bridge **34**, **134** based on the d-q transformation. First, the output voltage of the hybrid transformer **10**, **100** is transformed from abc (a and a imaginary axis) to d-q axis, using the phase angle from the phase lock loop for the primary side voltage. Functional block diagrams for the output voltage a-dq transformation are shown in FIG. **12**. The output d-q voltages are then compared with the reference output d-q voltages, respectively, and the differences are fed to PI regulators, respectively, to generate the d-q voltage references for the AC-AC converter. The goal of the controller **36**, **136** is to regulate the transformer output voltage to be 1.0 pu. Therefore, the vector magnitude is compared with 1.0 pu, i.e., V_{d_ref} is set to be 1.0 pu, which means the output voltage of the hybrid transformer **10**, **100** is regulated to be $480V/\sqrt{3}$ RMS. V_{q_ref} is set to 0, so that for the AC-AC converter **14**, the output voltage of the AC-AC converter **14** is in phase with the primary side voltage and the secondary winding **24**, and so that for the AC-AC converter **114**, the output voltage of the AC-AC converter **114** is in phase with

the source voltage and the primary winding **106**. Functional block diagrams for the d-q voltage control are shown in FIG. **13**. The d-q voltage references are transformed to a (and a imaginary) axis, which is then used for the modulation signal for the SPWM control. A functional block diagram for the d-q reference voltage to abc axis is shown in FIG. **14**. The SPWM modulation for the AC-AC converter **14** is shown in FIG. **15** and the SPWM modulation for the AC-AC converter **114** is shown in FIG. **16**.

In the hybrid transformers **10**, **100**, the AC-AC converters **14**, **114** are protected from short circuit faults.

In the hybrid transformer **10**, the controller **36** monitors the input voltage and the output current of the hybrid transformer **10**. If the output current exceeds a predetermined limit, thereby indicating a short circuit fault in the output, or the input voltage drops below a certain level, thereby indicating a short circuit fault in the input, the controller **36** stops the pulse width modulation of all of the switching devices **38**, i.e., turns off (opens) the switching devices **38**, thereby disconnecting the load from the source. In this manner, the AC-AC converter **14** acts as a circuit breaker.

In the hybrid transformer **100**, it is possible that the AC-AC converter **114** may be subject to the entire voltage in the event of a short circuit fault. In order to protect the AC-AC converter **114** from this increased voltage, the controller **136** monitors the voltage of the AC-AC converter **114**. If the voltage increases above a predetermined level, thereby indicating a fault, the controller **136** turns on (closes) the top four switching devices **38** designated $S1a$, $S1b$, $S2a$, $S2b$ (or the bottom four switching devices designated $S3a$, $S3b$, $S4a$, $S4b$) in the first switching bridge **130**, thereby causing the AC-AC converter **114** to be bypassed. In order to provide additional protection, a circuit breaker **170** may be connected between the source and the AC-AC converter **114**. The circuit breaker **170** may be a solid state circuit breaker or an electro-mechanical circuit breaker. In lieu of the circuit breaker **170**, a bypass switch **172** may be connected in parallel with the AC-AC converter **114**, between the AC-AC converter **114** and the primary winding **106**.

As described above, the hybrid transformers **10**, **100** each have three windings. It should be appreciated that a hybrid transformer embodied in accordance with the present invention may have less than three windings, i.e., may have a single primary winding and single secondary winding. Hybrid transformers **54**, **74** described below are two such examples.

Referring now to FIG. **17**, the hybrid transformer **54** includes an electromagnetic transformer **56**, which has a single primary winding **58** and a single secondary winding **57** with one or more taps. Each tap is connected to a turn of the secondary winding **57**, between ends of the secondary winding **57**. An inner tap **59** divides the secondary winding **57** into two winding portions **60** and **62**. The winding portion **60** is formed by the inner tap **59** and a first extremity of the secondary winding **57** or, alternately, another, outer tap. Similarly, the winding portion **62** is formed by the inner tap **59** and a second extremity of the secondary winding **57** or, alternately, another, outer tap. The primary and secondary windings are wound around a ferromagnetic core **64**. Power electronic module **65** is connected across the winding portion **62** of the secondary winding **57**. The voltage "AC output" is equal to the voltage across the winding portion **60** of the secondary winding plus the voltage across the power electronic module **65**. Since the output voltage equals the voltage output from the power electronic module **65** plus the

voltage of the winding portion **60**, control of the voltage output from the power electronic module **65** controls the output voltage of the hybrid transformer **54**. As will be described below, power electronic module **65** comprises a DC bus that can be used to power DC loads when the load is connected to DC output terminals **66** of the hybrid transformer **54**. An optional energy storage device, such as a battery **67**, can be connected across the DC output terminals **66** using a switch **68**.

Referring now to FIG. **18**, hybrid transformer **74** includes an electromagnetic transformer **76**, which has a single secondary winding **78** and a single primary winding **79** with one or more taps. Each tap is connected to a turn of the primary winding **79**, between ends of the primary winding **79**. An inner tap **81** divides the primary winding **79** into two winding portions **80** and **82**. The winding portion **80** is formed by the inner tap **81** and a first extremity of the primary winding **79** or, alternately, another, outer tap. Similarly, the winding portion **82** is formed by the inner tap **81** and a second extremity of the primary winding **79** or, alternately, another, outer tap. The primary and secondary windings are wound around a ferromagnetic core **75**. The power electronic module **65** is connected to the winding portion **82** of the primary winding **79**. The voltage V_{in} is equal to the voltage across the winding portion **80** plus the voltage across the power electronic module **65**. Since the input voltage equals the voltage output from the power electronic module **65** plus the voltage of the winding portion **80**, control of the voltage output from power electronic module **65** controls the input voltage and, thus, the output voltage of the hybrid transformer **74**.

Referring now to FIG. **19**, the power electronic module **65** comprises an AC-AC converter, two switches **84** and **86** and a fault current limiting assembly that includes an impedance or inductor **88** and an electronic switch **90**. As shown in FIG. **19**, the inductor **88** is connected in series with the electronic switch **90**. Each of the switches **84**, **86** may be a mechanical switch, an electronic switch or a hybrid mechanical/electronic switch. The switches **84**, **86** and the electronic switch **90** are controlled by the controller of the AC-AC converter. The AC-AC converter may be the AC-AC converter **14**, the AC-AC converter **114**, or an AC-AC converter having another, different type of topology. In the hybrid transformer **54**, the power electronic module **65** may utilize the AC-AC converter **14**, while in the hybrid transformer **74**, the power electronic module **65** may utilize the AC-AC converter **114**. If the power electronic module **65** utilizes the AC-AC converter **14**, the DC bus of the power electronic module **65** comprises the DC bridge **32**. If the power electronic module **65** utilizes the AC-AC converter **114**, the DC bus of the power electronic module **65** comprises the DC bridge **132**.

During normal operation of the power electronic module **65**, the switch **84** is closed and the switch **86** is open. If the power electronic module **65** malfunctions, a bypass can be created by opening the switch **84** and closing the switch **86**. During normal operation, the electronic switch **90** is open and load current flows through the DC-AC converter (second switching bridge **34** or **134**) of the AC-AC converter. During a network phase-to-ground or phase-to-phase fault, the DC-AC converter is blocked and the switch **90** is closed, forcing the fault current to pass through the impedance **88**. By introducing the impedance **88** during faults, the fault current is limited to protect the transformer and upstream equipment. Impedance **88** can be of resistive or inductive type.

It should be appreciated that the hybrid transformers **10**, **100** may be provided with the switches **84**, **86** and the

impedance **88** and the electronic switch **90** in the same arrangement (relative to the AC-AC converter **14**, **114**) and operating in the same manner as described above for the hybrid transformers **54**, **74**.

In each of the hybrid transformers **10**, **100**, **54**, **74**, the controller **36**, **136** may be an intelligent electronic device (IED) or may interface with an IED, wherein the IED controls and monitors operational aspects of the hybrid transformer **10**, **100**, **54**, **74** in addition to controlling the AC-AC converter **14**, **114**. Such an IED **160** is shown in FIG. **20** mounted on or proximate to the hybrid transformer **10**, **100**, **54**, **74**. The IED **160** includes a user interface, a processor, memory and a communication port. In addition to controlling the AC-AC converter **14**, **114** and the devices appurtenant thereto, the IED **160** monitors the operation of the hybrid transformer **10**, **100**, **54**, **74** and communicates operating information to a remotely located control center **162** over a communication link **164**, which may be a physical hardwired link, a satellite link, a cellular link, a modem or telephone line link, an Internet link or any other wireless or wide area or shared local area network link. For example, the currents, voltages and temperatures of the primary and/or secondary windings may be measured by sensors **161** that are connected for communication with the IED **160**. The IED **160** may periodically or continuously transmit values for these currents, voltages and temperatures over the communication link **164** to the control center **162** and/or may transmit alarms to the control center **162** over the communication link **164** if the values exceed certain predetermined limits. In addition to transmitting information about the primary and/or secondary windings, the IED **160** may transmit information about the operation of the AC-AC converter **14**, **114** to the control center **162** over the communication link **164**. Moreover, the IED **160** may receive and implement control commands from the control center **162** for changing the operation of the AC-AC converter **14**, **114**.

In addition to communicating with the control center **162**, the IED **160** may communicate with other IEDs. For example, the IED **160** may communicate with other IEDs **160** installed in other hybrid transformers **10**, **100**, **54**, **74** that are part of the same power distribution network. The IEDs **160** may communicate directly with each other or through a data server (not shown) located in the control center **162**. In the former case, the IEDs **160** may communicate directly with each other via radio frequency transceivers, a wired or wireless local area network (LAN) or a communication bus. In the latter case, communication between each IED **160** and the data server occurs over the communication link **164**.

The IED **160** may support the IEC61850 standard and, in so doing, define abstract object models for electrical substations and a method for accessing these models over a network. The models can be mapped to a number of protocols, including Manufacturing Message Specification (MMS), Generic Object Oriented Substation Events (GOOSE), Generic Substation Status Event (GSSE), and Sampled Measured Values (SMV). These protocols can run over TCP/IP networks and/or LANs using high speed switched Ethernet.

Instead of using an IED to transmit operating information to a remotely located control center, transmitters may be used to do so. The transmitters may be connected to the sensors **161** and may transmit the values measured by the sensors to a remote location, such as the control center **162**, via a communication link, which may be wireless, or hardwired.

The DC taps **48, 50, 52, 150** may be connected to provide DC power to the sensors **161**, transmitters and other communication devices that are used to monitor and transmit data concerning the operation of the hybrid transformer **10, 100, 54, 74**. The DC taps **48, 50, 52, 150** may also be connected to provide DC power to the controller **36, 136** and/or IED **160**. Depending on the application of the hybrid transformer **10, 100, 54, 74**, the DC taps may be connected to provide DC power to equipment associated with the application.

In each of the AC-AC converters **14, 114** a battery bank **162** and associated switch may be connected in parallel with the DC bridge **32, 132**, as shown in FIG. **21** for the AC-AC converter **14**. When the IED **160** detects a voltage sag or interruption, the IED **160** may close the switch and connect the battery bank **162** to the second switching bridge **34** so as to provide DC power to the second switching bridge **34** to compensate for the loss or sag. A trickle charger or float charger connected to the DC bridge **32** may keep the battery bank **162** fully charged when the battery bank is not being utilized. In lieu of having the battery bank **162** connected in parallel with the DC bridge **32, 132**, the battery bank **162** may be connected into the DC bridge **32, 132** and may replace the capacitors. Still another option is to connect a battery bank **67** across the DC output terminals of the hybrid transformer **10, 100, 54, 74**, such as is shown in FIGS. **17, 18**.

Three of the single-phase hybrid transformers **10, 100, 54, 74** can be connected to form a three-phase transformer. The connection can be Y-Y, Y- Δ , Δ -Y, or Δ - Δ . In this embodiment, the controllers **36, 136** for the hybrid transformers **10, 100, 54, 74** would be synchronized to provide balanced three-phase power.

Referring now to FIG. **22**, a three-phase hybrid transformer **200** may be provided having a three-phase electromagnetic transformer **202** and a three-phase AC-AC converter. In the hybrid transformer **200**, the same principles of voltage regulation and power factor correction remain the same as that described above for the single-phase hybrid transformer **10, 100, 54, 74**. The AC-AC converter may be comprised of three units **206a, b, c**, one for each phase, wherein each unit **206** has substantially the same construction as the AC-AC converter **14** or the AC-AC converter **114** except the controller for the three-phase hybrid transformer is adapted to control three-phase currents and voltages instead of single-phase currents and voltages.

It should be appreciated that multiphase hybrid transformers may be provided having more than three phases. For such multiphase hybrid transformers, the same principles of voltage regulation and power factor correction remain the same as that described above for the single-phase hybrid transformer **10, 100, 54, 74**.

The hybrid transformer **10, 100, 54, 74** of the present invention provides a number of benefits. The AC-AC converter **14, 114** is operable to control the power factor on the primary side of the hybrid transformer **10, 100**. In contrast, the power factor on the primary side of a conventional transformer depends on the load. In addition, the AC-AC converter **14, 114** is operable to reduce fluctuation in the output voltage of the hybrid transformer **10, 100, 54, 74** in the event of a sag or a swell in the input voltage. For example, in the event of an increase or decrease of 15% in the input voltage, the AC-AC converter **14, 114** can keep the fluctuation in output voltage to less than 5%. The input current of the hybrid transformer **10, 100, 54, 74** is also smaller than that of a conventional transformer because the hybrid transformer **10, 100, 54, 74** generates all the needed

reactive power and, thus, the voltage source only provides the real power to the load. The hybrid transformer **10, 100, 54, 74** may be used in datacenters, naval propulsion systems, automotive manufacturing facilities, pharmaceutical plants, hospitals, polymer processing plants, paper mills and wind farms.

An example of how a hybrid transformer embodied in accordance with the present invention can be used to more efficiently to replace a conventional power system is shown in FIGS. **23** to **27**.

Referring now to FIG. **23**, there is shown a simulation result for transient voltage regulation. The primary voltage has $\pm 20\%$ fluctuations that are compensated by the hybrid transformer to obtain a regulated secondary voltage.

Referring now to FIG. **24**, there is shown a simulation result for a 20% long time voltage sag. The primary voltage depression is compensated by the hybrid transformer to obtain a regulated secondary voltage. In this case the hybrid transformer exhibits an on-load tap changer functionality.

In FIG. **25(a)**, a conventional power system **250** for power factor correction is shown. The power system **250** includes a conventional electromagnetic transformer **260**, and a switchable capacitor bank **270**. The capacitor bank **270** is switched by incremental steps to provide reactive power needed for load power factor correction. This method is characterized by a slow response and a large footprint. The hybrid transformer **10, 100, 54, 74** shown in FIG. **25(b)** provides a continuous and fast change of reactive power output needed for power factor correction. It provides an integrated solution that requires less capacitor rating and a limited footprint.

In FIG. **26**, a power system **300** connecting two networks **310** and **320** using two parallel lines **330** and **340**. In practice, the parallel lines do not have the same impedance and the power flowing in one line is greater than that flowing in the other line. Under heavy load condition, one of the lines **330, 340** may be subjected to thermal overload, thereby causing line sags and mechanical stresses. When the hybrid transformer **10, 100, 54, 74** is placed in series with the line **330**, it allows control of power flow through line **330** by imposing a phase shift on the output voltage. The hybrid transformer **10, 100, 54, 74** can be placed in series with both of the lines **330** and **340** and control the power flow on that corridor.

In FIG. **27(a)**, a conventional power system **400** for a data center is shown. The power system **400** includes a conventional electromagnetic transformer **402**, a conventional uninterruptible power supply (UPS) **404**, a battery bank **406** and a rectifier **408**. The UPS **404** and the transformer **402** are connected to an AC voltage source and provide conditioned AC power to AC loads. The UPS **404** is connected to the battery bank **406** to provide AC power in the event of a failure of the voltage source. The rectifier **408** converts the conditioned AC power to DC power that is used to power DC loads, such as computers.

The conventional power system **400** can be replaced by an embodiment of the hybrid transformer **10, 100, 54, 74** having the battery bank **67** connected across the DC output terminals of the hybrid transformer through the switch **68**. As shown in FIG. **27(b)**, the DC loads are connected to the DC output terminals of the hybrid transformer **10, 100, 54, 74**. Under normal conditions, the battery bank **67** is maintained at full charge, but the switch **68** is open. DC power is provided to the DC loads from the AC-AC converter **14, 114**. Upon the occurrence of a power outage, the switch **68** closes

and DC power is supplied from the battery bank 67 to the DC loads until AC power is restored or a local generator unit is started.

The hybrid transformer 10, 100, 54, 74 with the battery bank 67 provides the same benefits as the conventional power system 400, but more efficiently and with less equipment.

As will be appreciated by one of skill in the art and as before mentioned, the present invention may be embodied as or take the form of the methods of controlling and monitoring hybrid transformers previously described, a computing device or system having program code configured to carry out the methods, a computer program product on a computer-usable or computer-readable medium having computer-usable program code embodied in the medium. The computer-usable or computer-readable medium may be any medium that can contain, store, communicate, propagate, or transport the program for use by or in connection with the instruction execution system, apparatus, or device and may by way of example but without limitation, be an electronic, magnetic, optical, electromagnetic, infrared, or semiconductor system, apparatus, device, or propagation medium or even be paper or other suitable medium upon which the program is printed. More specific examples (a non-exhaustive list) of the computer-readable medium would include: a portable computer diskette, a hard disk, a random access memory (RAM), a read-only memory (ROM), an erasable programmable read-only memory (EPROM or Flash memory), an optical fiber, a portable compact disc read-only memory (CD-ROM), an optical storage device, a transmission media such as those supporting the Internet or an intranet, or a magnetic storage device. Computer program code or instructions for carrying out operations of the present invention may be written in any suitable programming language provided it allows to achieve the previously described technical results. The program code may execute entirely on the user's computing device, partly on the user's computing device, as a stand-alone software package, partly on the user's computer and partly on a remote computer or entirely on the remote computer or server. In the latter scenario, the remote computer may be connected to the user's computer through a local area network (LAN) or a wide area network (WAN), or the connection may be made to an external computer (for example, through the Internet using an Internet Service Provider).

It is to be understood that the description of the foregoing exemplary embodiment(s) is (are) intended to be only illustrative, rather than exhaustive, of the present invention. Those of ordinary skill will be able to make certain additions, deletions, and/or modifications to the embodiment(s) of the disclosed subject matter without departing from the spirit of the invention or its scope, as defined by the appended claims.

What is claimed is:

1. A hybrid transformer having a primary side for receiving an input voltage and a current from a source and a secondary side for providing an output voltage and a current to a load, the hybrid transformer comprising:

a ferromagnetic core;

a first winding, a second winding and a third winding wound around the core, wherein at least one of the first, second and third windings is a primary winding for connection to the source, and at least one of the first, second and third windings is a secondary winding for connection to the load; and,

an AC-AC converter comprising:

a first switching bridge connected to the first winding such that the first switching bridge receives AC power from the first winding and converts the AC power to DC power;

a second switching bridge including an output connected to the second winding and structured to receive the converted DC power from the first switching bridge, convert the DC power to AC power, and provide the converted AC power to the load in parallel combination with unconverted AC power from the second winding effective to augment the AC power provided to the load;

a DC bridge connected between the first and second switching bridges; and

a controller that controls each of the first and second switching bridges to reduce variations in the output voltage in the event of a change in the input voltage, the controller further controlling the first and second switching bridges to continuously control a power factor on the primary side of the hybrid transformer, the controller configured to disconnect the load from the source by opening the first and second switching bridges when the output current exceeds a predetermined limit or when the input voltage drops below a predetermined limit.

2. The hybrid transformer of claim 1, wherein the first and second windings are secondary windings and the third winding is the primary winding.

3. The hybrid transformer of claim 1, wherein the first and second windings are primary windings and the third winding is the secondary winding.

4. The hybrid transformer of claim 1, wherein the DC bridge comprises a plurality of capacitors and one or more taps for providing DC power to a DC load.

5. The hybrid transformer of claim 4, further comprising a normally open switch and a battery bank connected in parallel with the DC bridge, wherein when an interruption occurs in the input voltage, the switch closes, thereby providing DC power from the battery bank to the second switching bridge.

6. The hybrid transformer of claim 4, further comprising sensors and a monitoring device for monitor the operation of the hybrid transformer, the monitoring device being connected to the one or more taps to receive DC power from the DC bridge.

7. The hybrid transformer of claim 6, wherein the monitoring device is an intelligent electronic device (IED) that receives operational data of the hybrid transformer from the sensors, the operational data including currents, voltages and temperatures in the first, second and third windings.

8. The hybrid transformer of claim 7, wherein the IED comprises the controller.

9. The hybrid transformer of claim 8, wherein the IED is connected to a remotely located control center by a communication link, the IED transmitting the operational data to the control center and receiving, commands for the controller from the control center.

10. A hybrid transformer for receiving an input voltage and current from a source and providing an output including an output voltage and current to a load, the hybrid transformer comprising:

a ferromagnetic core;

a first winding, a second winding and a third winding wound around the core, wherein at least one of the first, second and third windings is a primary winding for connection to the source, and at least one of the first,

15

second and third windings is a secondary winding for connection to the load; and,
an AC-AC converter comprising:

a first switching bridge connected to the first winding;
a second switching bridge connected in series with the second winding;

a DC bridge connected between the first and second switching bridges; and

a controller that controls each of the first and second switching bridges to control the DC voltage across the DC bridge to reduce variations in the output voltage in the event of a change in the input voltage, wherein the controller is structured to operate the second switching bridge so as to receive DC power from the first switching bridge, convert the DC power to AC power, and provide the AC power to the load,

wherein the output power includes an AC power transmitted with the second winding unconverted by the first or second switching bridge in addition to the AC power provided with the second switching bridge.

11. The hybrid transformer of claim 10, further comprising sensors and an intelligent electronic device (IED) that is connected to a remotely located control center by a communication link, the IED comprising the controller and being operational to receive operational data from the sensors, transmit the operational data to the control center and receive commands for the controller from the control center.

12. A hybrid distribution transformer having a primary side for receiving an input voltage and a current from a source and a secondary side for providing an output power including an output voltage and a current to a load, the hybrid distribution transformer comprising:

a ferromagnetic core;

a first winding and a second winding wound around the core, the first winding having opposing ends, a plurality of turns disposed between the ends and a tap connected to one of the turns, the tap helping define winding portions of the first winding, and wherein one of the first and second windings is a primary winding for connection to the source, and the other one of the first and second windings is a secondary winding for connection to the load;

a power electronic module connected to the tap of the first winding and comprising an AC-AC converter including a first converter and a second converter, the first converter being connected in parallel with the second converter and the second converter including an output being connected to the tap; and

a control device that controls the power electronic module to receive AC power with the first converter, to convert the received AC power to DC power with the first converter, to receive the converted DC power with the second converter, to convert the DC power to AC power with the second converter, to provide the converted AC power to the load, to regulate variations in the output voltage, to increase voltage across the first winding, and to decrease voltage across the first winding, as well as to control a power factor on the primary side of the hybrid distribution transformer,

wherein the output power includes unconverted AC power transmitted with the first winding, and wherein only a portion of the AC power transmitted with the first winding is the AC power provided with the second converter.

13. The hybrid distribution transformer of claim 12, wherein the first winding is the primary winding and the second winding is the secondary winding.

16

14. the hybrid distribution transformer of claim 12 wherein the first winding is the secondary winding and the second winding is the primary winding.

15. The hybrid distribution transformer of claim 12, further comprising first and second switches, the first switch being connected in series with an input to the first converter and the second switch being connected in parallel with an output of the second converter.

16. The hybrid distribution transformer of claim 15, wherein each of the first and second switches is a mechanical switch, an electronic switch or a hybrid electronic/mechanical switch.

17. The hybrid distribution transformer of claim 15, wherein the first and second switches are controlled by the control device such that when the AC-AC converter is determined to be operating normally, the first switch is maintained in a closed position and the second switch is maintained in an open position, and when the AC-AC converter is determined to not be operating normally, the first switch is opened and the second switch is closed, thereby causing the AC-AC converter to be bypassed.

18. The hybrid distribution transformer of claim 15, further comprising a fault current limiting assembly comprising a normally open electronic switch connected in series with an inductor, the fault current limiting assembly being connected in parallel with the second switch and the second converter, the electronic switch being controlled by the control device such that when a fault is detected, the control device closes the electronic switch.

19. The hybrid distribution transformer of claim 12, wherein the AC-AC converter further comprises a DC bus having at least one capacitor and one or more DC taps.

20. The hybrid distribution transformer of claim 19, wherein the one or more DC taps comprise a plurality of taps at different DC voltage levels.

21. The hybrid distribution transformer of claim 12, wherein the first converter is connected in parallel with the first one of the winding portions using the tap and an end of the first winding.

22. The hybrid distribution transformer of claim 12, wherein the tap is a first tap and the first winding further comprising a second tap connected to another one of the turns of the first winding; and

wherein the first converter is connected in parallel with the first one of the winding portions using the first and second taps.

23. The hybrid distribution transformer of claim 12, wherein the hybrid transformer is a distribution transformer.

24. The hybrid distribution transformer of claim 12, further comprising sensors and an intelligent electronic device (IED) that is connected to a remotely located control center by a communication link, the IED comprising the controller and being operable to receive operational data from the sensors, transmit the operational data to the control center and receive commands for the controller from the control center.

25. The hybrid transformer of claim 1, wherein the AC-AC converter includes a filter including at least one passive component, an input connected with the output of the second switching bridge, and an output connected in series with the second winding.

26. The hybrid transformer of claim 1, wherein the output of the second switching bridge is directly connected to the second winding.