

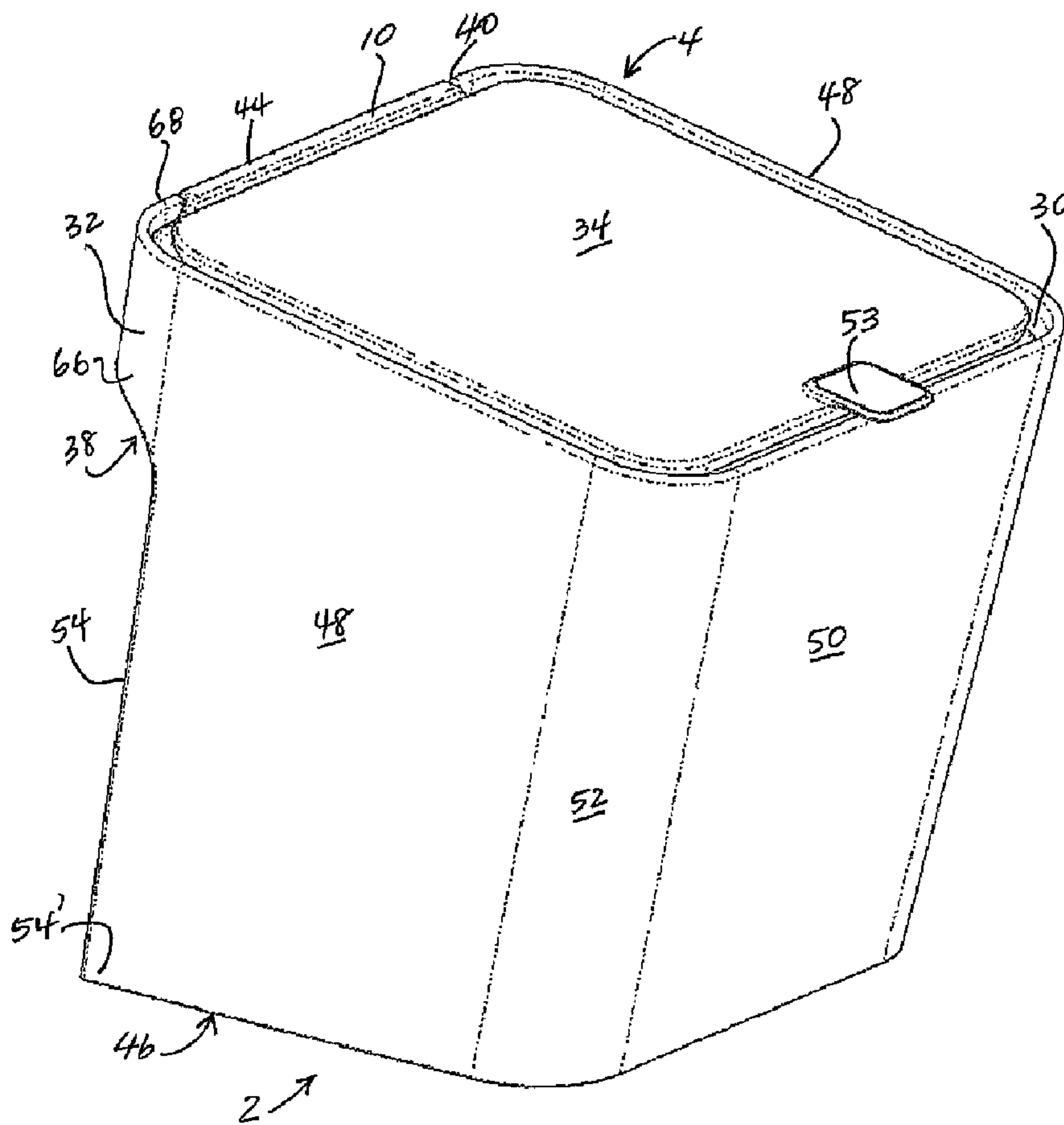

(22) Date de dépôt/Filing Date: 2012/01/13  
 (41) Mise à la disp. pub./Open to Public Insp.: 2012/07/15  
 (30) Priorités/Priorities: 2011/01/15 (US61/461,201);  
 2011/03/07 (US13/041,551)

(51) Cl.Int./Int.Cl. *B65F 1/06* (2006.01),  
*B65F 1/14* (2006.01)  
 (71) Demandeur/Applicant:  
 ICAN PRODUCTS, LLC, US  
 (72) Inventeurs/Inventors:  
 HELLER, CAROLYN YECIES, US;  
 LUKIC, BRANKO, US;  
 MORRISSEY, ANNE, US;  
 TAKAYAMA, STEVEN R., US  
 (74) Agent: RIDOUT & MAYBEE LLP

(54) Titre : CONTENANT  
 (54) Title: CONTAINER



(57) Abrégé/Abstract:

In one embodiment, an apparatus comprises a bin having an open end; a bag mounting ring mounted inside a perimeter of the bin adjacent to the open end; a handle, having two ends that extend inside and are coupled by pivots to inside walls of the bin, and a



(57) **Abrégé(suite)/Abstract(continued):**

top bar that fits inside the bin when the handle is closed; wherein the bag mounting ring comprises offset ring portions that are configured to clear the handle when the handle is closed. In another embodiment, an apparatus comprises a bin having a floor, side walls and an open end; a bag mounting ring mounted inside a perimeter of upper wall portions of the bin adjacent to the open end; a lid that is movable on pivots on the upper wall portions, wherein the lid fits over and at least partially covers the ring when the lid is closed.

## ABSTRACT

In one embodiment, an apparatus comprises a bin having an open end; a bag mounting ring mounted inside a perimeter of the bin adjacent to the open end; a handle, having two ends that extend inside and are coupled by pivots to inside walls of the bin, and a top bar that fits inside the bin when the handle is closed; wherein the bag mounting ring comprises offset ring portions that are configured to clear the handle when the handle is closed. In another embodiment, an apparatus comprises a bin having a floor, side walls and an open end; a bag mounting ring mounted inside a perimeter of upper wall portions of the bin adjacent to the open end; a lid that is movable on pivots on the upper wall portions, wherein the lid fits over and at least partially covers the ring when the lid is closed.

## CONTAINER

### BENEFIT CLAIM

[0001] This application claims the benefit under 35 U.S.C. 119(e) of United States provisional patent application, number to be supplied by amendment, mailed and intended to be filed on January 15, 2011, entitled "ICAN, LLC WASTE BUCKET" and filed *pro se* by named inventor Anne Morrissey and naming as inventors Carolyn Yecies Heller, Branko Lukic, Anne Ballinger Morrissey, and Steve Takayama, the entire contents of which are hereby incorporated by reference for all purposes as if fully set forth herein.

### TECHNICAL FIELD

[0002] The present disclosure generally relates to containers. The disclosure relates more specifically to containers for temporarily holding waste materials or materials intended for other uses such as recycling.

### BACKGROUND

[0003] The approaches described in this section are approaches that could be pursued, but not necessarily approaches that have been previously conceived or pursued. Therefore, unless otherwise indicated, it should not be assumed that any of the approaches described in this section qualify as prior art merely by virtue of their inclusion in this section.

[0004] Municipalities are increasingly requesting or requiring customers to recycle new kinds of household waste such as food scraps. Typically consumers collect food scraps in a container in the kitchen or other food preparation area and then transport the container to a curbside collection bin shortly before a scheduled time for collection of the contents of the bin.

[0005] Waste disposal containers are typically formed as buckets with or without handles and with or without lids. These designs fill a need, but also create problems for users when users transport and dump the contents. Typical waste disposal containers also are structured with the majority of their functional parts, such as the handle, on the exterior. Such an arrangement typically results in an unattractive appearance; the handle or other external functional parts may create obstacles for storage, or opportunities for breakage or entanglement with other objects in the environment. Typical waste disposal containers also are complex to use. Some users require

a bag in the container, while for other users factors such as ease of placement, secure placement and removal are important. Still other users need a way to separate different kinds of contents within a given container.

#### SUMMARY OF THE INVENTION

[0006] The invention may be summarized based upon the appended claims.

#### BRIEF DESCRIPTION OF THE DRAWINGS

[0007] In the drawings:

[0008] FIG. 1 is a perspective view of a container apparatus of one embodiment;

[0009] FIG. 2 is a front elevation view of a container apparatus of one embodiment;

[0010] FIG. 3 is a side elevation view of a container apparatus of one embodiment;

[0011] FIG. 4 is a rear elevation view of a container apparatus of one embodiment;

[0012] FIG. 5 is a top plan view of a container apparatus of one embodiment with lid closed;

[0013] FIG. 6 is an exploded perspective view of a container apparatus of one embodiment;

[0014] FIG. 7 is a section view taken on lines A-A of FIG. 17;

[0015] FIG. 8 is a perspective view of a container apparatus of one embodiment showing lid closed and carry handle partially raised;

[0016] FIG. 9 is a perspective view of a container apparatus of one embodiment showing lid closed and carry handle fully raised;

[0017] FIG. 10 is a perspective view of a container apparatus of one embodiment showing lid open and carry handle down and with a bag mounting ring omitted or removed;

[0018] FIG. 11 is a perspective view of a container apparatus of one embodiment showing lid open and carry handle down and with a bag mounting ring installed;

[0019] FIG. 12 is a perspective view of a container apparatus of one embodiment showing lid open and carry handle down and with a bag mounting ring installed and pivoted upward in a first direction;

[0020] FIG. 13 is a perspective view of a container apparatus of one embodiment showing lid open and carry handle down and with a bag mounting ring installed and pivoted upward in a second direction;

- [0021] FIG. 14 is a partial perspective view of a container apparatus of one embodiment showing detail of a carry handle pivot and tilted bag mounting ring;
- [0022] FIG. 15 is a partial perspective view of a container apparatus of one embodiment showing detail of a tilted bag mounting ring;
- [0023] FIG. 16 is a perspective view of an upper end of a container apparatus of one embodiment showing details of pivots for a bag mounting ring and for a lid;
- [0024] FIG. 17 is a top plan view of a container apparatus of one embodiment with lid omitted to illustrate interior details;
- [0025] FIG. 18 illustrates four (4) views A, B, C, D of an example carry handle and comprising a perspective view (A), end elevation view (B), top plan view (C), and side elevation view (D);
- [0026] FIG. 19 illustrates four (4) views A, B, C, D of an example bag mounting ring and comprising a top plan view (A), end elevation view (B), side elevation view (C), and perspective view (D).
- [0027] The drawings are not rendered to scale.

#### DETAILED DESCRIPTION

[0028] In the following description, for the purposes of explanation, numerous specific details are set forth in order to provide a thorough understanding of the present invention. It will be apparent, however, that the present invention may be practiced without these specific details. In other instances, well-known structures and devices are shown in block diagram form in order to avoid unnecessarily obscuring the present invention.

#### [0029] 1.0 OVERVIEW

[0030] In an embodiment, a container comprises a bin, a concealable handle, a pivoting bag mounting ring that is positioned within and spaced apart from the handle, and a pivoting lid that is closable within the handle and providing means for ventilating contents of the bin.

[0031] In an embodiment, two or more upper wall portions of the bin comprise an inwardly extending lip and wherein the bag mounting ring is seated on the lips. In an embodiment, the bag mounting ring comprises outwardly extending pins that are snugly engaged in the pivots on the inside walls of the bin. In an embodiment, the pins are formed at midpoints of side ring

portions of the bag mounting ring and are configured to permit the bag mounting ring to pivot upwardly or downwardly within the bin.

**[0032]** In an embodiment, the apparatus further comprises a movable lid having pivot mouths that snugly engage pivot rods formed in an upper wall portion of the bin, wherein the lid is configured to fit inside the handle and over the bag mounting ring when the lid and the handle are closed. In an embodiment, the lid is formed having at least one perimeter dimension that is smaller than an inside dimension of the open end and defining a ventilation gap between the bin and the lid when the lid is closed. In an embodiment, the pivots are offset from a rear edge of the lid.

**[0033]** In an embodiment, the apparatus further comprises a non-movable grab handle formed integrally with and extending outwardly from an upper portion of a rear side wall of the bin. In an embodiment, the grab handle comprises end arms formed integrally with the upper portion and comprising pivot rods, and the apparatus further comprises a pivoting lid having pivot mouths that snugly engage the pivot rods, wherein the lid is configured to fit inside the handle and over the ring when the lid and the handle are closed.

**[0034]** In an embodiment, the grab handle comprises an upper rear edge that is configured to stop rearward pivoting of the lid when the lid is open. In an embodiment, the grab handle comprises a bottom edge defining an open region that is configured to hang. In an embodiment, an elongated recess is in an upper rear edge of the grab handle and a corresponding finger grip ridge is formed on a grip position of the grab handle.

**[0035]** In an embodiment, an apparatus, comprises a bin having a floor, side walls and an open end; a bag mounting ring mounted inside a perimeter of upper wall portions of the bin adjacent to the open end; a lid that is movable on pivots on the upper wall portions, wherein the lid fits over and at least partially covers the ring when the lid is closed.

**[0036]** In an embodiment, each upper wall portion of the bin comprises one or more inwardly extending lips and wherein the bag mounting ring is seated on the lips. In an embodiment, the bag mounting ring is mounted using outwardly extending pivot pins that are snugly engaged in pivots that are formed on the inside walls of the bin. In an embodiment, the bag mounting ring is mounted using outwardly extending pivot pins that are snugly engaged in pivots that are formed on the pivoting ends of the handle. In an embodiment, the pins are formed

at midpoints of side ring portions of the bag mounting ring and are configured to permit the bag mounting ring to pivot upwardly or downwardly within the bin.

**[0037]** In an embodiment, the apparatus further comprises a pivoting lid having pivot mouths that snugly engage pivot rods formed in an upper wall portion of the bin, wherein the lid is configured to fit inside the handle and over the bag mounting ring when the lid and the handle are closed. In an embodiment, the lid has at least one perimeter dimension that is smaller than an inside dimension of the open end and defining a ventilation gap between the bin and the lid when the lid is closed. In an embodiment, the pivots are offset from a rear edge of the lid.

**[0038]** In an embodiment, the apparatus further comprises a non-pivoting grab handle formed integrally with and extending outwardly from an upper portion of a rear side wall of the bin. In an embodiment, the grab handle comprises end arms formed integrally with the upper portion and comprising pivot rods, the apparatus further comprising a pivoting lid having pivot mouths that snugly engage the pivot rods, wherein the lid is configured to fit inside the handle and over the ring when the lid and the handle are closed. In an embodiment, the grab handle comprises an upper rear edge that is configured to stop rearward pivoting of the lid when the lid is open.

**[0039]** In an embodiment, the grab handle comprises a bottom edge defining an open region that is configured to hang. In an embodiment, the apparatus further comprises an elongated recess in an upper rear edge of the grab handle and a corresponding finger grip ridge formed on a grip position of the grab handle.

**[0040]** In an embodiment, a container comprises a bin, lid, handle and ring that allow opening, filling and emptying the bin. In one embodiment, the container can allow for the separation of different waste streams such as food waste and garbage. In an embodiment as further detailed herein, the lid may be more easily opened than prior designs, more easily filled because of the lid design described herein, and easily emptied due to the handle design.

**[0041]** In addition, in an embodiment the placement of a bag inside easier to accomplish, more aesthetic and securely fixed in place by means of a pivoting offset bag mounting ring as more further described herein. The ring may be flexible and may hold more than one bag. The ring may allow for variable volume within the attached bag. The ring may be structured in several different sizes and the overall perimeter size of the ring is not critical to an embodiment.

[0042] The bag ring may be inside of the can, and as a result the ring may allow the handle to be hidden. The bag ring or frame may be made of a minimum amount of material to accomplish secure bag placement. The bag ring or frame may be attached to the can with a pivoting pin into a boss, a slot, a knob or simply rest on a step on the can inner surface. The boss or slot also can be formed in or as part of the pivoting ends of the carry handle. The inner ring may allow for ventilation of the can by means of an offset construction that forms a gap around a perimeter of the lid.

[0043] In an embodiment, a handle is structured and affixed in a manner that permits dumping the container using a single hand. The one hand dump handle may be facilitated by the design of the inner ring because of its location inside of the bin.

[0044] In an embodiment, the lid is pivotally affixed in a manner that permits the lid to stay open on its own, with gravity, facilitating the use and filling of the bucket.

[0045] The carry handle may be hidden from view when it is not in use.

[0046] In an embodiment, a bag mounting ring enables many desirable features of the apparatus such as a concealable carry handle and a grab handle that is configured for one hand disposal operation. In an embodiment, the bag mounting ring comprises an open frame not coupled to or including an inner bucket that has sufficient physical strength and material to securely hold and retain a bag or liner in or to the container. In an embodiment, the bag mounting ring may be mounted in the container in several different ways, such as a pivoting pin that is snugly received in a boss, a slot, or a cantilever, which may be on inner walls of the bin or on a carry handle. In an embodiment, the bag mounting ring is seated inside the container on a step or lip that extends inwardly from on the inner surface of the container.

[0047] In an embodiment, the bag mounting ring enables several desirable features. For example, the bag mounting ring enables a user to achieve a hidden liner bag. When a liner bag is installed on the bag mounting ring and the lid of the container is closed, the bag may be entirely hidden from view, which makes the container appear neat and attractive. As another example, because the liner bag does not over the outer rim of the bin, the container may comprise a carry handle just inside a perimeter of upper walls of the bin, resulting in a simple and attractive appearance.

[0048] Further, because the bag does not hang over the outer rim of the bin, a grab handle for one hand disposal may be integrated into the outer edge of the bin. As yet another example,

integrated ventilation is provided; because the bag can be attached away from the upper edge of the bin, ventilation can be incorporated using a gap between the lid and upper edges of upper walls of the bin, without perforating the lid of the can. This feature is desirable in part because a simplified look is achieved.

**[0049]** In an embodiment, the container comprises an integrated carry handle that may be hidden from view when closed. One benefit of this arrangement is that the container appears simple and elegant. In an embodiment, a top edge of the carry handle is seated in a corresponding recess of a grab handle of a rear wall of the bin. In this arrangement, when closed, the handle remains visible to enable a user to rapidly locate and access the handle. The handle when closed also does not interfere with use or operation of the lid or bin when a user is disposing of the contents of the bin. The handle is configured to remain away from a path of the contents of the bin when the bin is emptied. In particular, in an embodiment, the handle cannot be positioned in front of the lid and therefore it is not possible to pour or spill contents of the bin onto the handle.

**[0050]** In an embodiment, the container comprises a grab handle integrally formed with a rear wall of the bin that facilitates intuitive one handed disposal operations. In an embodiment, the grab handle is configured to permit a user to empty the bin with only one hand. The location of the grab handle allows the user to open the lid with the thumb or other fingers of a hand while holding the bin with the same hand. The grab handle also allows the user to invert the bin while keeping the lid open with the same hand. Use of the grab handle is also intuitive. By grabbing the grab handle in a natural way, the way to open the lid becomes apparent to the user as the user's thumb naturally rests on an area of the lid that may be pressed to open the lid.

**[0051]** In an embodiment, the lid incorporates a tab or other protrusion that overhangs the front edge of the bin. By lifting up on the tab, the lid can be opened. The lid is easy to open because there is no latch; instead, the lid stays closed by gravity. When the lid is in the open position, it also stays open by gravity. When open, the lid rests in a position just past the point of balance, and therefore, the lid is easy to close by tapping the lid, nudging the lid, or shaking the bin. In another embodiment, the lid may omit a tab but may extend beyond the front edge of the bin, and the region of the lid that extends beyond the front edge of the bin may be used to lift the lid.

**[0052]** In an embodiment, the container incorporates visually integrated ventilation. In an embodiment, ventilation of the bin is achieved using a specified gap between the lid and the upper edge of upper side walls of the bin. Because the bag liner is attached away from the edge of the bin, a gap may be defined between the lid and the bin. The gap allows air to circulate and reduces undesirable odor buildup, which can occur in other containers when the contents are foods that undergo anaerobic decomposition while in a sealed container. The ventilation does not require perforations in the lid. The lid is simple in appearance and is easy to clean.

**[0053]** 2.0 EXAMPLE MECHANICAL CONFIGURATION

**[0054]** An example container apparatus is now described with reference to the examples shown in the drawings.

TABLE OF PARTS AND ELEMENTS

**[0055]** The following reference numerals identify the following elements:

2	bin	4	open end
6	bag mounting ring	8	inside upper perimeter of bin
10	carry handle	11	side arms of carry handle
12	end of carry handle	14	pivot for carry handle
16	inside wall of bin	18	top bar of carry handle
20	offset ring portion	21	rear ring portion
22	upper wall portion of bin	24	inwardly extending lip
26	outwardly extending pins on ring	28	pivots for bag mounting ring
30	ventilation gap of lid	32	grab handle
34	lid	36	pivot mouth
38	bottom edge of grab handle	40	elongated recess
42	upper rear edge of grab handle	44	finger grip ridge
46	floor of bin	48	side wall of bin
50	front wall of bin	52	curved transition of side wall
53	lifting tab of lid	54	rear wall of bin
54'	obtuse angle at which floor meets rear wall	56	midpoint
58	side ring portion	60	pivot rod
66	curved transition	68	rear grab handle wall
70	curved edge	72	gap

74	badge	76	pivot boss
78	edge of bag mounting ring	80	retaining clip
82	slot in upper rear wall	84	side ring portion
86	transitions in ring	88	front ring portion

**[0056]** FIG. 1 is a perspective view of a container apparatus. In general a container apparatus, in one embodiment, comprises a bin 2 having a floor 46, front wall 50, side walls 48, and rear wall 54 defining an open upper end 4 that may be closed by a movable lid 34. Each of the floor and walls 50, 48, 54 may be generally planar and formed using thermoplastics, such as injection molded plastics that produce integrally formed parts, or wood, metals, composites, glass, or other materials. In an embodiment, front wall 50 joins side walls 48 using integral smoothly curved transitions 52 whereas rear wall 54 joins the side walls at a more sharply defined angle which may be a right angle.

**[0057]** In an embodiment, floor 46 joins rear wall 54 at an acute angle 54'; the particular measurement of the angle is not critical but an angle of approximately 70 degrees could be used. Further, in an embodiment floor 46 joins front wall 50 at a complementary obtuse angle so that the bin 2 as a whole has a forward thrusting appearance. The forward thrusting appearance in part provides a distinctive ornamental design that is not purely functional or required for the functionality of the other features herein. For example, the bin 2 could be cylindrical or oval with partially linear sections to support the handle, bag mounting ring, or other features that are described herein as wall mounted.

**[0058]** In an embodiment, lid 34 comprises an attached or integrally formed generally planar lifting tab 53 that extends outwardly from the lid 34 beyond a plane of the front wall 50. In this arrangement, grasping and upwardly moving the lifting tab 53 may cause the lid 34 to move upward and to open by pivoting on pivots located on a rear portion of the lid and engaging a corresponding pivot rod formed in an upper portion of the rear wall, in a manner that is further described and illustrated herein.

**[0059]** In an embodiment, side walls 48 are joined by smoothly curved transition segments 66 to a grab handle 32 that extends along a rear portion of the bin and above rear wall 54. Grab handle 32 is further defined by a rear grab handle arm or wall 68 that extends along an entire rear

portion of the bin and is separated from rear wall 54 at its bottom edge 38 thereby defining a hanger by which the bin may hang on a separate wall.

**[0060]** For example, a user could install a plurality of spaced apart fasteners such as screws on a wall of a kitchen, pantry, garage or other generally vertical planar surface and then hang the bin 2 on the fasteners by placing bottom edge 38 of grab handle 32 on the fasteners. Thus, the grab handle 32 may also serve as convenient means for hanging the bin.

**[0061]** In an embodiment, the container apparatus includes a movable carry handle 10 that is concealable below the lid 34 when the carry handle is in a down position. Carry handle 10 includes a finger grip ridge 44 at a grip position of the carry handle that protrudes upwardly and outwardly behind the lid 34 and rests in an elongated recess 40 formed in an upper portion of the rear grab handle wall 68.

**[0062]** FIG. 2 is a front elevation view of a container apparatus of one embodiment. In FIG. 2, front wall 50 may be seen as smoothly joined by transitions 52 to side walls 48. Lid 34 is illustrated in the closed position with carry handle 10 down and partially concealed under the lid such that only side portions and finger grip edge 44 of the carry handle are visible. In FIG. 2 side ring portions 58 of a bag mounting ring may be seen; the bag mounting ring is further described herein.

**[0063]** FIG. 3 is a side elevation view of a container apparatus of one embodiment. FIG. 3 further clarifies that in an embodiment, floor 46 joins rear wall 54 at the acute angle 54' and the floor joins front wall 50 at a complementary obtuse angle so that the bin 2 as a whole has a forward thrusting appearance.

**[0064]** FIG. 3 further shows that grab handle 32 may be integrally formed with side walls 48 and may be defined by a curved edge 70 that transitions the grab handle to rear wall 54. In this arrangement the bin 2 may be lifted and carried using a single hand by placing the fingers under edge 38 and in a gap 72 formed between rear grab handle wall 68 and rear wall 54 of the bin.

**[0065]** FIG. 4 is a rear elevation view of a container apparatus of one embodiment. FIG. 4 further illustrates the structure of grab handle 32, which may join side walls 48 using smoothly curved transitions 66 that define curved edges 70. In this view gap 72 is apparent beneath the grab handle 32 and under its bottom edge 38. Placing the fingers of a user's hand in gap 72 typically causes the palm to rest against grab handle 32 and the thumb to rest over finger grip

ridge 44 and an upper rear edge 42 of the grab handle, which is thereby retained in a closed position against recess 40.

[0066] FIG. 5 is a top plan view of a container apparatus of one embodiment with lid closed. FIG. 5 illustrates that when lid 34 is closed and carry handle 10 is in a down position, side arms 11 of the carry handle rest inside an interior perimeter of upper portions of side walls 48 and grab handle 32 thereby providing almost complete concealment of the handle. Finger grip edge 44 of the handle 10 remains visible at the rear of the bin 2 so that a user can rapidly locate and lift the carry handle.

[0067] A bag mounting ring 6 is also seated within an inside upper perimeter 8 of upper portions of the side walls and front wall 50. Bag mounting ring 6 comprises offset ring portions 20 that clear the carry handle arms 11 when the handle is down. Both the bag mounting ring 6 and ends 12 of the carry handle 10 may be affixed to interior upper portions of side walls 48 using a common pivot, details of which are further illustrated herein.

[0068] In this arrangement the carry handle 10 may be lifted upwardly or moved downwardly by pivoting motion of ends 12 on the side pivots, and the bag mounting ring 6 may be separately or concurrently lifted upwardly or downwardly to facilitate installing or removing a bag or liner. The bag mounting ring 6 in this arrangement is positioned adjacent to upper wall portions 22 of the bin 2 as best seen in FIG. 11.

[0069] Further, in this arrangement the lid 34 is formed having perimeter dimensions that are smaller than the upper perimeter or open end 4 of the bin 2 to define a perimeter ventilation gap 30 at adjacent to all edges of the lid. The lid 34 does not fall downward into the open end 4 because tab 53 acts as a stop and because an inside surface of the lid rests on portions of the bag mounting ring. In other embodiments, the lid 34 may omit the tab 53 and may extend outwardly beyond the upper perimeter or open end of the bin 2 so that the over-extending region of the lid provides a lifting surface and also prevents the lid from falling downwardly into the bin. In this disclosure, all references to tab 53 are intended to broadly include the alternative embodiment in which lid 34 omits a tab and instead has a size or region that extends beyond the perimeter of the bin 2.

[0070] FIG. 6 is an exploded perspective view of a container apparatus of one embodiment. FIG. 6 may further clarify a relationship of rear wall 54 to grab handle 32 and gap 72, which may receive fingers of a hand for one-handed lifting of the bin 2. FIG. 6 further shows carry handle

10 comprising top bar 18 joined to or integrally formed with handle arms 12, which terminate at their ends in generally circular holes or pivots 14. Handle 10 incorporates finger grip ridge 44 that may rest in elongated recess 40 of the grab handle 32 when the handle is closed. Pivots 14 may be affixed to corresponding pivot bosses 76 on the inside walls 16 of side walls 48 using a snap fit arrangement or other fasteners such as screws, rivets, or press-fit retainers.

**[0071]** Bag mounting ring 6 comprises a generally quadrilateral integrally formed ring having offset ring portions 20 that clear the handle 10 when the handle is closed. Bag mounting ring 6 may comprise outwardly extending pins 26 that may snugly fit into pivot bosses 76 over and through pivots 14 of the carry handle 10 such that the bag mounting ring is mounted within the handle. Thus pins 26 and pivot bosses 76 when mounted together collectively act as pivots 28 for the bag mounting ring 6. Pins 26 may be formed generally near midpoints of side portions of the bag mounting ring to facilitate balanced movement or pivoting of the bag mounting ring as further illustrated and described. Alternatively, in an embodiment, the bag mounting ring is mounted using outwardly extending pivot pins that are snugly engaged in pivots that are formed on the pivoting ends 12 of the carry handle 10.

**[0072]** Bag mounting ring 6 may comprise an outwardly extending ridge 78 along an entire perimeter of the ring to provide rigidity and strength for the ring, and the ridge may be friction fitted into a plurality of inwardly extending lips 24 when the ring is in the bin 2. In this arrangement the friction connection of ridge 78 into lips 24 retains the bag mounting ring 6 in alignment with upper edges of the side walls 48, but permits the ring to be rotated or moved on the pivot pins 26 by gently urging the ring upwardly or downwardly against and beyond lips 24.

**[0073]** Optionally, bag mounting ring 6 may include one or more bag retaining clips 80 that protrude downwardly and include a narrow slot into which excess bag material may be gathered and cinched to snugly retain the bag in position on the ring.

**[0074]** Lid 34 may include a badge 74 that is printed or colored with indicia such as a brand name and may be attached to tab 53 using adhesive or other means of affixation.

**[0075]** Operational aspects of an embodiment based on the preceding description may be further understood with reference to FIG. 8, FIG. 9, FIG. 10, FIG. 11, FIG. 12, and FIG. 13, which illustrate an embodiment in various combinations of positions of the carry handle, lid, and bag mounting ring. For example, FIG. 8 is a perspective view of a container apparatus of one embodiment showing lid closed and carry handle partially raised.

[0076] The structural arrangement described above enables the handle 10 to be lifted using finger grip edge 44 or other means and raised above the closed lid 34 without interfering with the lid or the bag mounting ring, which is concealed in FIG. 8. Ends 12 of the carry handle 10 extend between the perimeter edges of the lid 34 and inside the side walls 48 to rotate on pivot bosses 76, which are concealed in FIG. 8.

[0077] FIG. 9 is a perspective view of a container apparatus of one embodiment showing lid closed and carry handle fully raised and illustrating the same structural relationships as described above for FIG. 8.

[0078] FIG. 10 is a perspective view of a container apparatus of one embodiment showing lid open and carry handle down and with a bag mounting ring omitted or removed. FIG. 10 shows that lid 34 may comprise a pair of pivot mouths 36 formed in one end of the lid. The pivot mouths 36 engage and are snugly retained against one or more pivot rods that are formed adjacent to an upper edge of rear wall 54 of bin 2. A snap fit of the pivot mouths to the pivot rods may be used to facilitate assembly. The pivot mouths 36 may be formed at a position that is inwardly offset from a rear edge of the lid 34 so that when the lid is opened, a rear portion of the lid rotates into a portion of the gap 72 that is formed between rear wall 54 of bin 2 and rear grab handle wall 68.

[0079] In an embodiment, rear wall 54 may incorporate slots 82 that receive and act as stops for arms 12 of carry handle 10 when the carry handle is down.

[0080] FIG. 11 is a perspective view of a container apparatus of one embodiment showing lid open and carry handle down and with a bag mounting ring installed. FIG. 11 shows that in an embodiment, bag mounting ring 6 may mount on the same pivot bosses 76 on which ends 12 of the carry handle rotate, and the bag mounting ring is positioned inside the carry handle ends and inside the side walls 48, front wall 50, and rear wall 54 of bin 2. In particular, a rear ring portion 21 of bag mounting ring 6 rests nearly adjacent to rear wall 54.

[0081] Perimeter edge 78 is snugly retained in inwardly extending lips 24 but still allows the bag mounting ring 6 to be moved upwardly or downwardly within the bin 2 and without interfering with the carry handle. For example, FIG. 12 is a perspective view of a container apparatus of one embodiment showing lid open and carry handle down and with a bag mounting ring installed and pivoted upward in a first direction. FIG. 13 is a perspective view of a container apparatus of one embodiment showing lid open and carry handle down and with a bag

mounting ring installed and pivoted upward in a second direction. FIG. 12, FIG. 13 illustrate that movement of the bag mounting ring is independent of the carry handle and provides great flexibility for the user in mounting or removing a bag or liner.

**[0082]** FIG. 14 is a partial perspective view of a container apparatus of one embodiment showing detail of a carry handle pivot and tilted bag mounting ring. FIG. 14 shows that lid 34 having pivot mouths 36 that are snugly retained against pivot rods, not visible in FIG. 15, formed under or extending from upper end corners 84 of rear wall 54. Ends 12 of carry handle 10 are seated in slots 82 of the upper part of rear wall 54.

**[0083]** FIG. 15 is a partial perspective view of a container apparatus of one embodiment showing detail of a tilted bag mounting ring. FIG. 15 shows that bag mounting ring 6 may be tilted upward while rotating on the same pivot bosses 76 on which pivots 14 of ends 12 of the carry handle rotate. Edge 78 of the bag mounting ring 6 may be retained by friction in the inwardly extending lips 24.

**[0084]** FIG. 16 is a perspective view of an upper end of a container apparatus of one embodiment showing details of pivots for a bag mounting ring and for a lid. FIG. 16 is a rearward side view toward an inside upper portion of a side wall 48. FIG. 16 shows, on inside walls 16 of bin 2, pivot bosses 76 that may concurrently bear the outwardly extending pins 26 of the bag mounting ring 26 and the pivots 14 of the carry handle 10, both of which are omitted for clarity. Example details of rear wall 54 may be seen including slots 82 that may receive arms of the carry handle. Pivot rods 60 may be formed in or extend from upper end corners 84 of rear wall 54.

**[0085]** FIG. 17 is a top plan view of a container apparatus of one embodiment with lid omitted to illustrate interior details. FIG. 17 is a downward view through an open end 4 of bin 2 and toward floor 46. FIG. 17 shows, on inside walls 16 of bin 2, pivot bosses 76 that may concurrently bear the outwardly extending pins 26 of the bag mounting ring 26 and the pivots 14 of the carry handle 10, both of which are omitted for clarity. Example details of rear wall 54 may be seen including slots 82 that may receive arms of the carry handle. Pivot rods 60 may be formed in or extend from upper end corners 84 of rear wall 54. A position of gap 72 is defined between rear wall 54 and grab handle 32.

**[0086]** FIG. 7 is a section view taken on lines A-A of FIG. 17 in a rotated orientation such that open end 4 of bin 2 is at the left of the view and floor 46 is oriented vertically at the right of

the view. FIG. 7 shows gap 72 between grab handle 32 and rear wall 54. FIG. 7 shows pivot boss 76 on an inside wall 16 of a side wall, pivot rods 60 formed at rear wall 54 and inwardly extending lips 24 for retaining the bag mounting ring, which is omitted for purposes of clarity.

**[0087]** FIG. 18 illustrates four (4) views A, B, C, D of an example carry handle and comprising a perspective view (A), end elevation view (B), top plan view (C), and side elevation view (D). In all the views, FIG. 18 shows an example carry handle 10 comprising side arms 11 and ends 12 integrally formed with or joined to top bar 18, which further comprises an outwardly extending finger grip ridge 44. Ends 12 terminate in pivots 14 to engage pivot bosses 76 of the bin 2.

**[0088]** FIG. 19 illustrates four (4) views A, B, C, D of an example bag mounting ring and comprising a top plan view (A), end elevation view (B), side elevation view (C), and perspective view (D). In all the views, FIG. 19 shows an example bag mounting ring 6 comprising offset ring portions 20 joined to or integrally formed with a rear ring portion 21 and side ring portions 84 that may use smoothly curved transitions 86 to join a front ring portion 88.

**[0089]** Pins 26 may be formed generally near midpoints of side portions of the bag mounting ring to facilitate balanced movement or pivoting of the bag mounting ring as further illustrated and described.

**[0090]** In this arrangement, when mounted in the bin 2, front ring portion 88 is generally adjacent to an inside of the front wall 50 and side ring portions 84 are generally adjacent to insides 16 of side walls 48. The offset ring portions 20 clear side arms 11 of the carry handle when the carry handle is closed and outwardly extending pins 26 may rotate in pivot bosses 76 to permit moving the ring 6.

**[0091]** 3.0 OTHER EMBODIMENTS, EXTENSIONS AND IMPROVEMENTS

**[0092]** Certain embodiments illustrated and described herein are shown as comprising the combination fundamentally of bin 2, lid 34, carry handle 10, and bag mounting ring 6. However, other embodiments may omit one or more of these elements. For example, one embodiment may comprise bin 2, lid 34, and carry handle 10 while omitting the bag mounting ring 6; this embodiment may be appropriate for applications that do not need a bag or liner. Another embodiment may comprise bin 2, lid 34, and bag mounting ring 6 while omitting the carry handle 10. Another embodiment may comprise bin 2, carry handle 10 while omitting the bag

mounting ring 6 and lid 34. Another embodiment may comprise bin 2, and bag mounting ring 6 while omitting the carry handle 10 and lid 34.

**[0093]** Yet another embodiment may comprise bin 2, with or without carry handle 10, with or without lid 34, and omitting bag mounting ring 6 but additionally including a plurality of inwardly protruding features on inside walls of the bin that will hold a bag. The protruding features may comprise hangers for a bag. The bag could also be a custom bag specifically designed to work with bin 2. An embodiment that uses interior bag hangers or other protruding features for grasping or holding a bag may be desirable because it eliminates a part and reduces complexity of use because one can use it with or without a bag without making a decision to remove or otherwise reconfigure the bin; cost may also be reduced.

**[0094]** Certain embodiments have been illustrated and described as having a ventilated lid 34. In another embodiment, lid 34 may form a snug seal over bin 2, or the lid may incorporate holes, mesh, screen, or other means for ventilation. Any such embodiment may include carry handle 10 or bag mounting ring 6, or both the carry handle 10 and bag mounting ring.

**[0095]** In the foregoing specification, embodiments of the invention have been described with reference to numerous specific details that may vary from implementation to implementation. Thus, the sole and exclusive indicator of what is the invention, and is intended by the applicants to be the invention, is the set of claims that issue from this application, in the specific form in which such claims issue, including any subsequent correction. Any definitions expressly set forth herein for terms contained in such claims shall govern the meaning of such terms as used in the claims. Hence, no limitation, element, property, feature, advantage or attribute that is not expressly recited in a claim should limit the scope of such claim in any way. The specification and drawings are, accordingly, to be regarded in an illustrative rather than a restrictive sense.

**[0096]** For example, all parts described herein may be formed or manufactured in any of several different kinds of materials including plastic, metal or wood materials. Embodiments are not limited to holding waste, but may be used for holding or containing any material that can be contained or disposed, or benefit from the disposal in this manner. For example, embodiments may be used for recyclable materials, parts, toys, foods, animal feed, or other materials that are edible, inert, or bulk.

## CLAIMS

What is claimed is:

1. An apparatus, comprising:  
a bin having an open end;  
a bag mounting ring mounted inside a perimeter of the bin adjacent to the open end;  
a handle, having two ends that extend inside and are coupled by pivots to inside walls of the bin, and a top bar that fits inside the bin when the handle is closed;  
wherein the bag mounting ring comprises offset ring portions that are configured to clear the handle when the handle is closed.
2. The apparatus recited in claim 1 wherein two or more upper wall portions of the bin comprise an inwardly extending lip and wherein the bag mounting ring is seated on the lips.
3. The apparatus recited in claim 1 wherein the bag mounting ring comprises outwardly extending pins that are snugly engaged in the pivots on the inside walls of the bin.
4. The apparatus recited in claim 3 wherein the pins are formed at midpoints of side ring portions of the bag mounting ring and are configured to permit the bag mounting ring to pivot upwardly or downwardly within the bin.
5. The apparatus recited in claim 1 further comprising a movable lid having pivot mouths that snugly engage pivot rods formed in an upper wall portion of the bin, wherein the lid is configured to fit inside the handle and over the bag mounting ring when the lid and the handle are closed.
6. The apparatus recited in claim 5 wherein the lid is formed having at least one perimeter dimension that is smaller than an inside dimension of the open end and defining a ventilation gap between the bin and the lid when the lid is closed.

7. The apparatus recited in claim 5 wherein the pivots are offset from a rear edge of the lid.

8. The apparatus recited in claim 1 further comprising a non-movable grab handle formed integrally with and extending outwardly from an upper portion of a rear side wall of the bin.

9. The apparatus recited in claim 8 wherein the grab handle comprises end arms formed integrally with the upper portion and comprising pivot rods, the apparatus further comprising a pivoting lid having pivot mouths that snugly engage the pivot rods, wherein the lid is configured to fit inside the handle and over the ring when the lid and the handle are closed.

10. The apparatus recited in claim 9 wherein the grab handle comprises an upper rear edge that is configured to stop rearward pivoting of the lid when the lid is open.

11. The apparatus recited in claim 8 wherein the grab handle comprises a bottom edge defining an open region that is configured to hang.

12. The apparatus recited in claim 8 further comprising an elongated recess in an upper rear edge of the grab handle and a corresponding finger grip ridge formed on a grip position of the grab handle.

13. An apparatus, comprising:  
a bin having a floor, side walls and an open end;  
a bag mounting ring mounted inside a perimeter of upper wall portions of the bin adjacent to the open end;  
a lid that is movable on pivots on the upper wall portions, wherein the lid fits over and at least partially covers the ring when the lid is closed.

14. The apparatus recited in claim 13 wherein each upper wall portion of the bin comprises one or more inwardly extending lips and wherein the bag mounting ring is seated on the lips.

15. The apparatus recited in claim 13 wherein the bag mounting ring is mounted using outwardly extending pivot pins that are snugly engaged in pivots that are formed on the inside walls of the bin.

16. The apparatus recited in claim 16 wherein the pins are formed at midpoints of side ring portions of the bag mounting ring and are configured to permit the bag mounting ring to pivot upwardly or downwardly within the bin.

17. The apparatus recited in claim 13 further comprising a pivoting lid having pivot mouths that snugly engage pivot rods formed in an upper wall portion of the bin, wherein the lid is configured to fit inside the handle and over the bag mounting ring when the lid and the handle are closed.

18. The apparatus recited in claim 17 wherein the lid has at least one perimeter dimension that is smaller than an inside dimension of the open end and defining a ventilation gap between the bin and the lid when the lid is closed.

19. The apparatus recited in claim 17 wherein the pivots are offset from a rear edge of the lid.

20. The apparatus recited in claim 13 further comprising a non-pivoting grab handle formed integrally with and extending outwardly from an upper portion of a rear side wall of the bin.

21. The apparatus recited in claim 20 wherein the grab handle comprises end arms formed integrally with the upper portion and comprising pivot rods, the apparatus further

comprising a pivoting lid having pivot mouths that snugly engage the pivot rods, wherein the lid is configured to fit inside the handle and over the ring when the lid and the handle are closed.

22. The apparatus recited in claim 21 wherein the grab handle comprises an upper rear edge that is configured to stop rearward pivoting of the lid when the lid is open.

23. The apparatus recited in claim 20 wherein the grab handle comprises a bottom edge defining an open region that is configured to hang.

24. The apparatus recited in claim 20 further comprising an elongated recess in an upper rear edge of the grab handle and a corresponding finger grip ridge formed on a grip position of the grab handle.

25. An apparatus, comprising:  
a bin having an open end;  
a handle, having two ends that extend inside and are coupled by pivots to inside walls of the bin, and a top bar that fits inside the bin when the handle is in a downward position;  
a movable lid configured to fit inside the handle and over an open end of the bin when the lid and the handle are in downward or closed positions.

Fig. 1

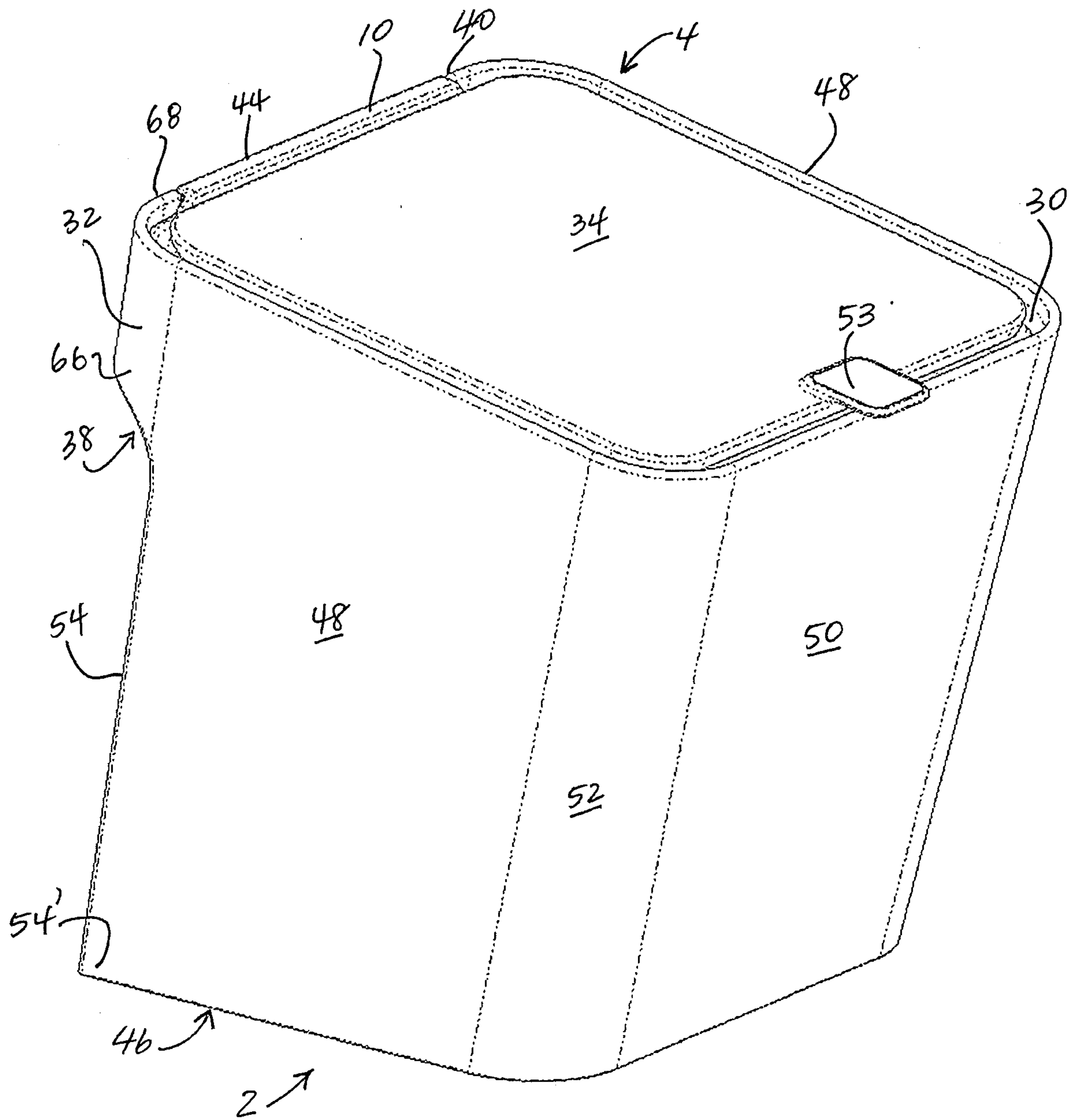

Fig. 2

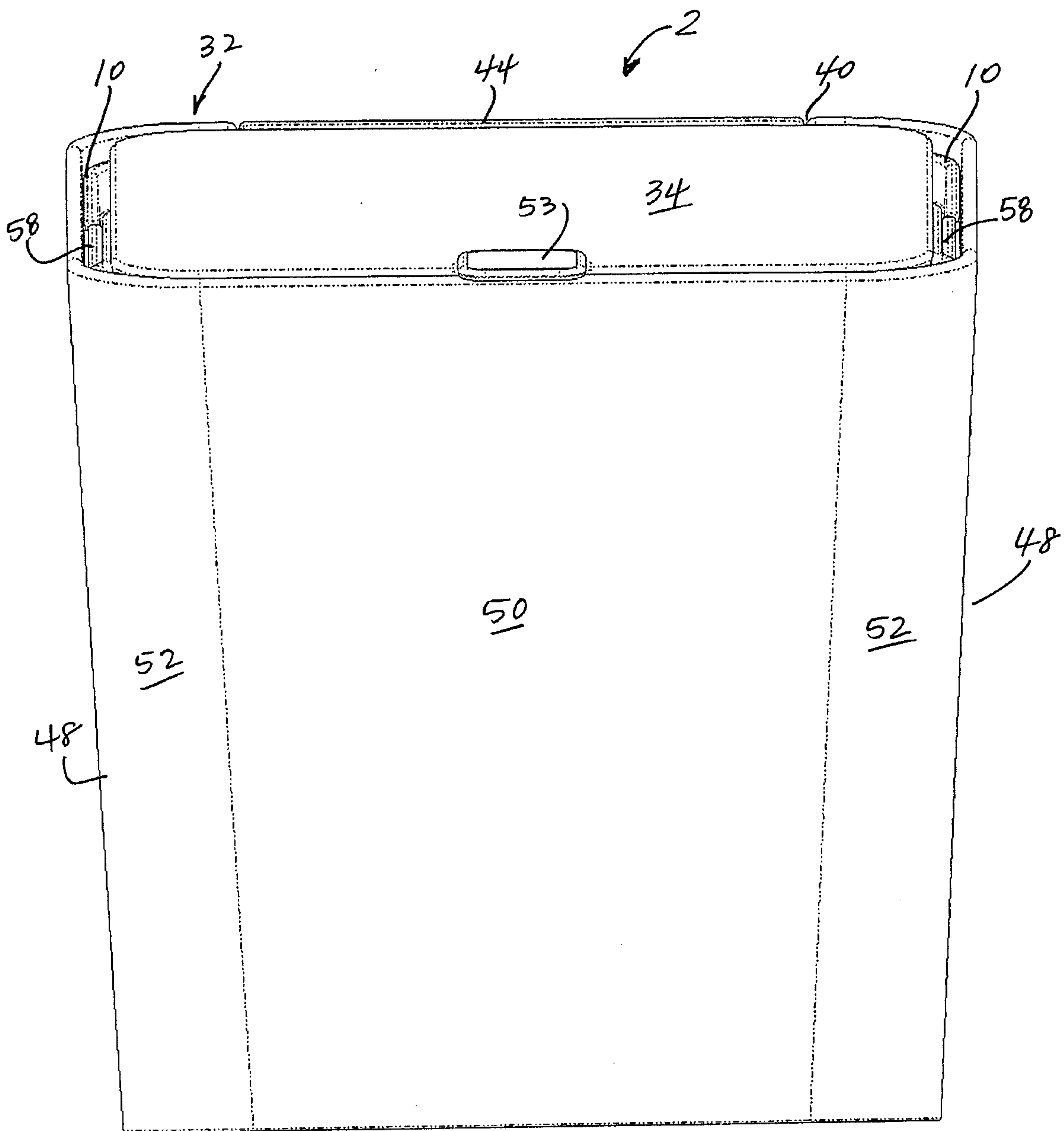

Fig. 3

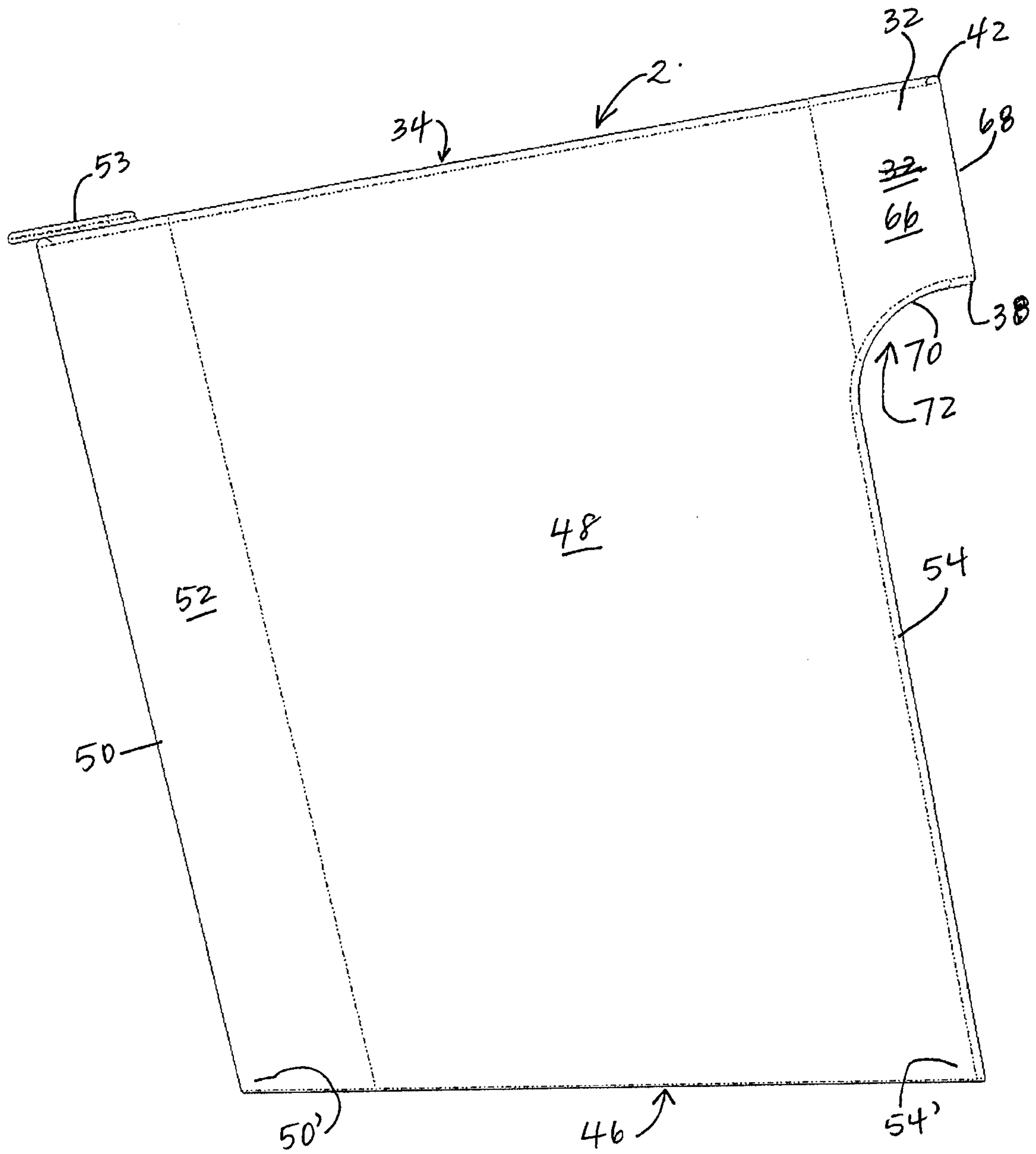

Fig. 4

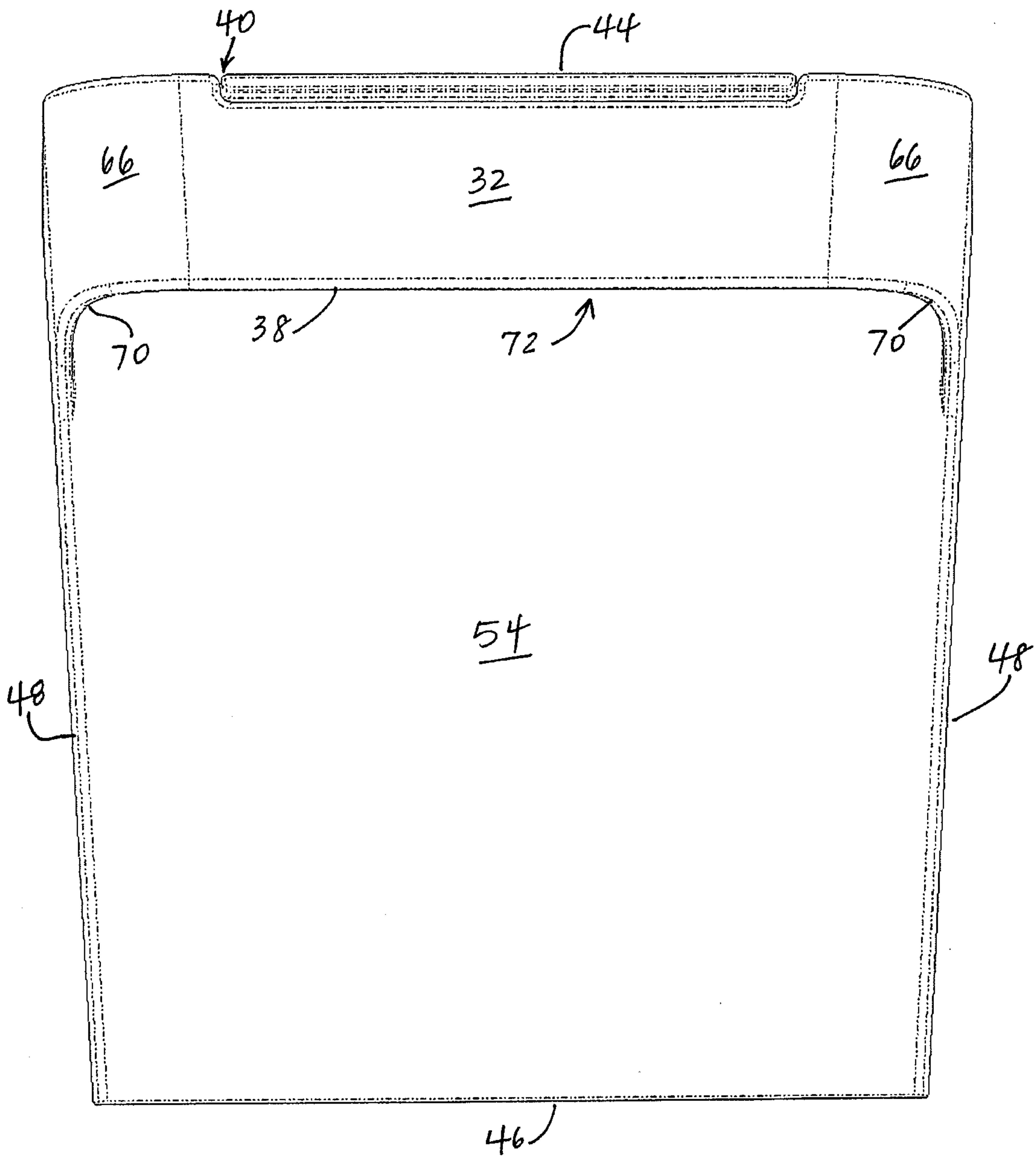
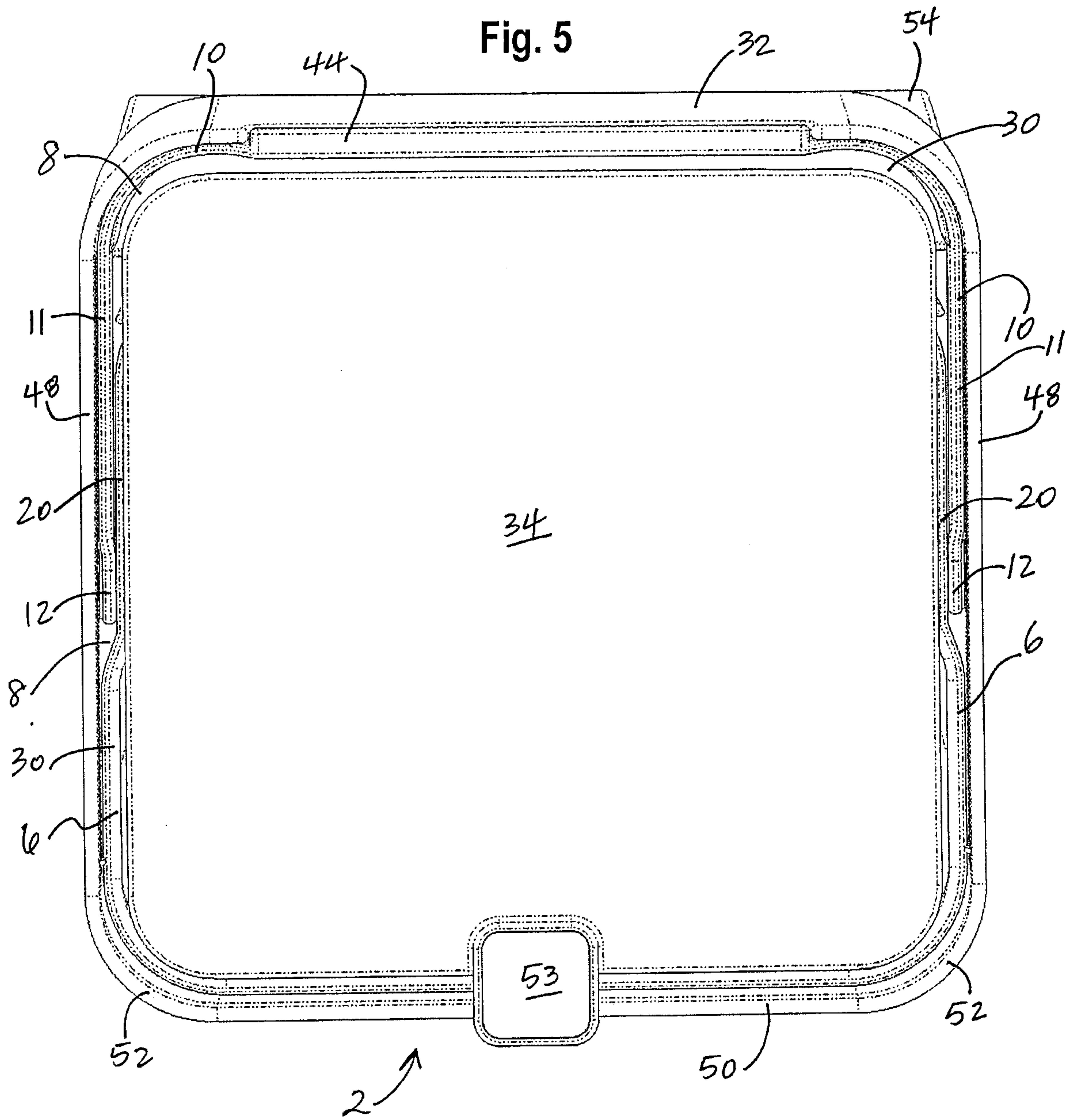
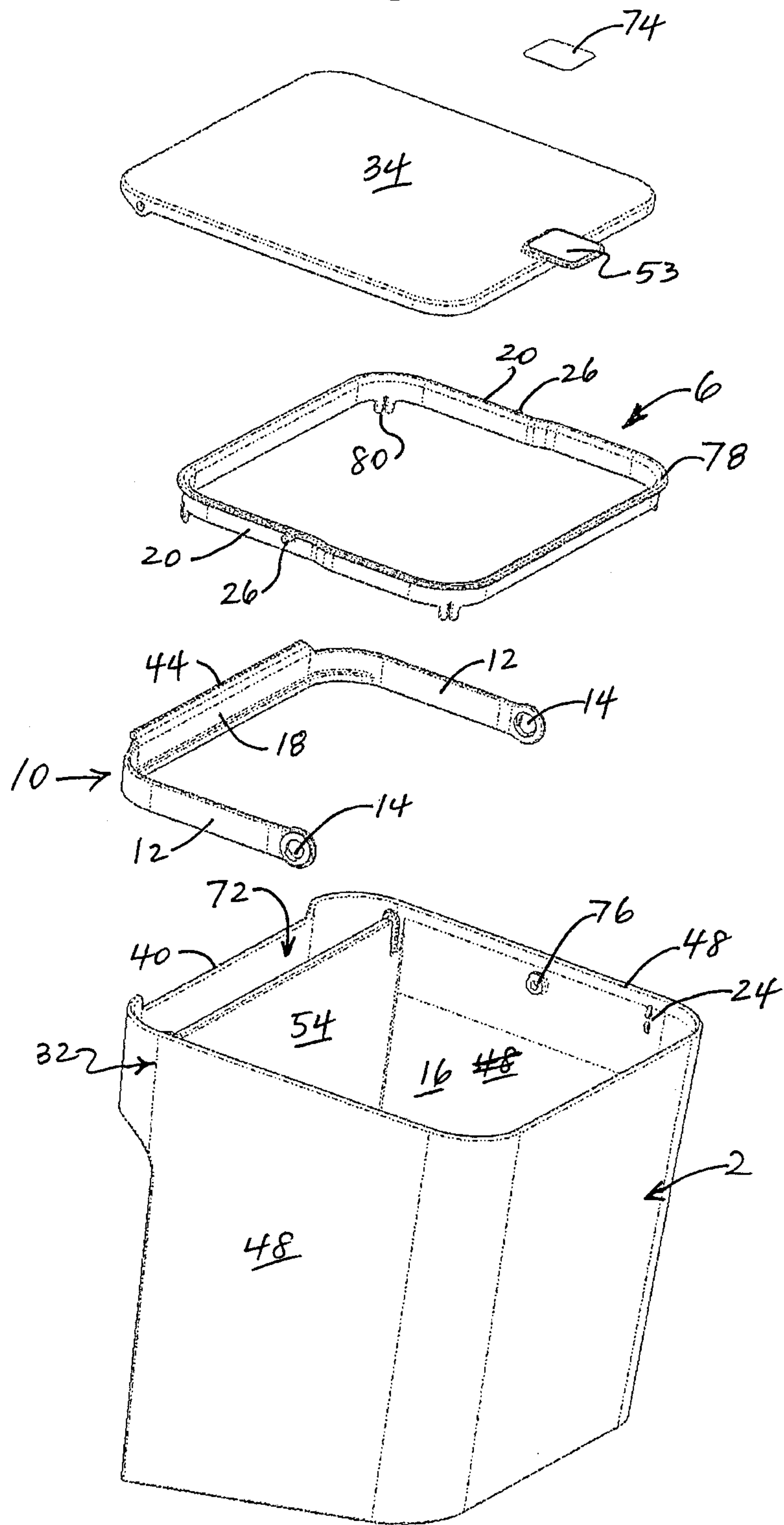

Fig. 5



6/18

Fig. 6



7/18

Fig. 7

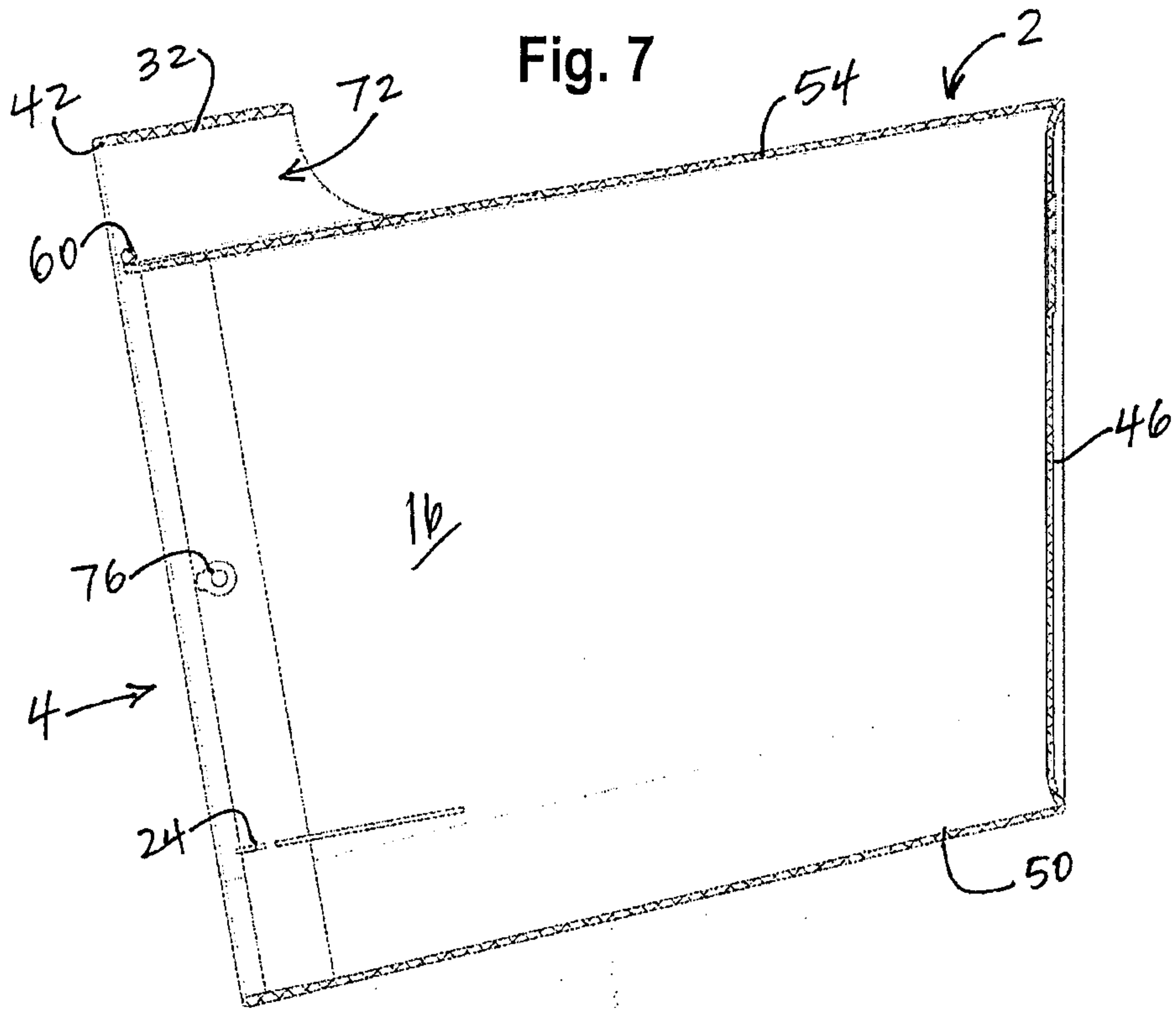

Fig. 16

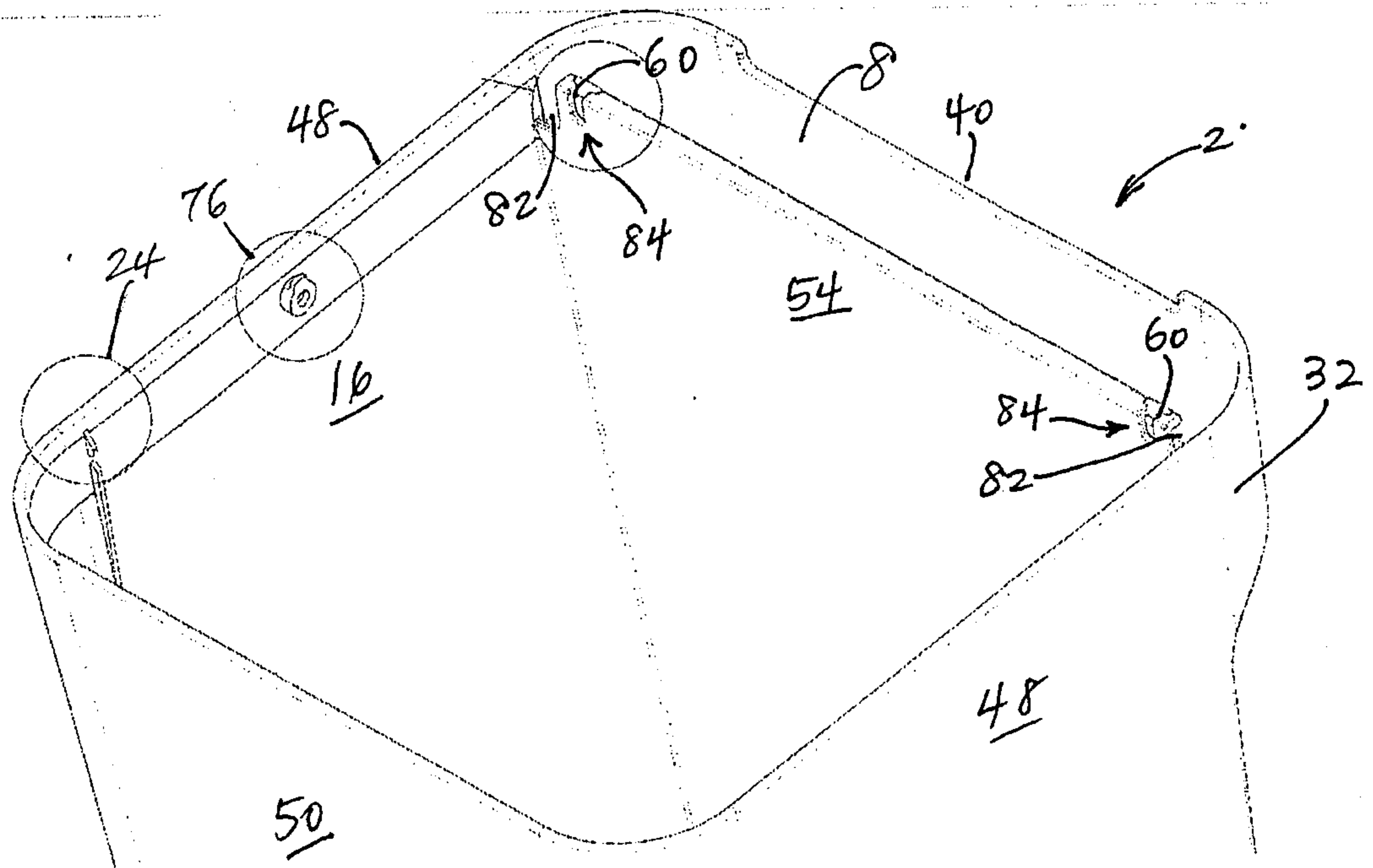
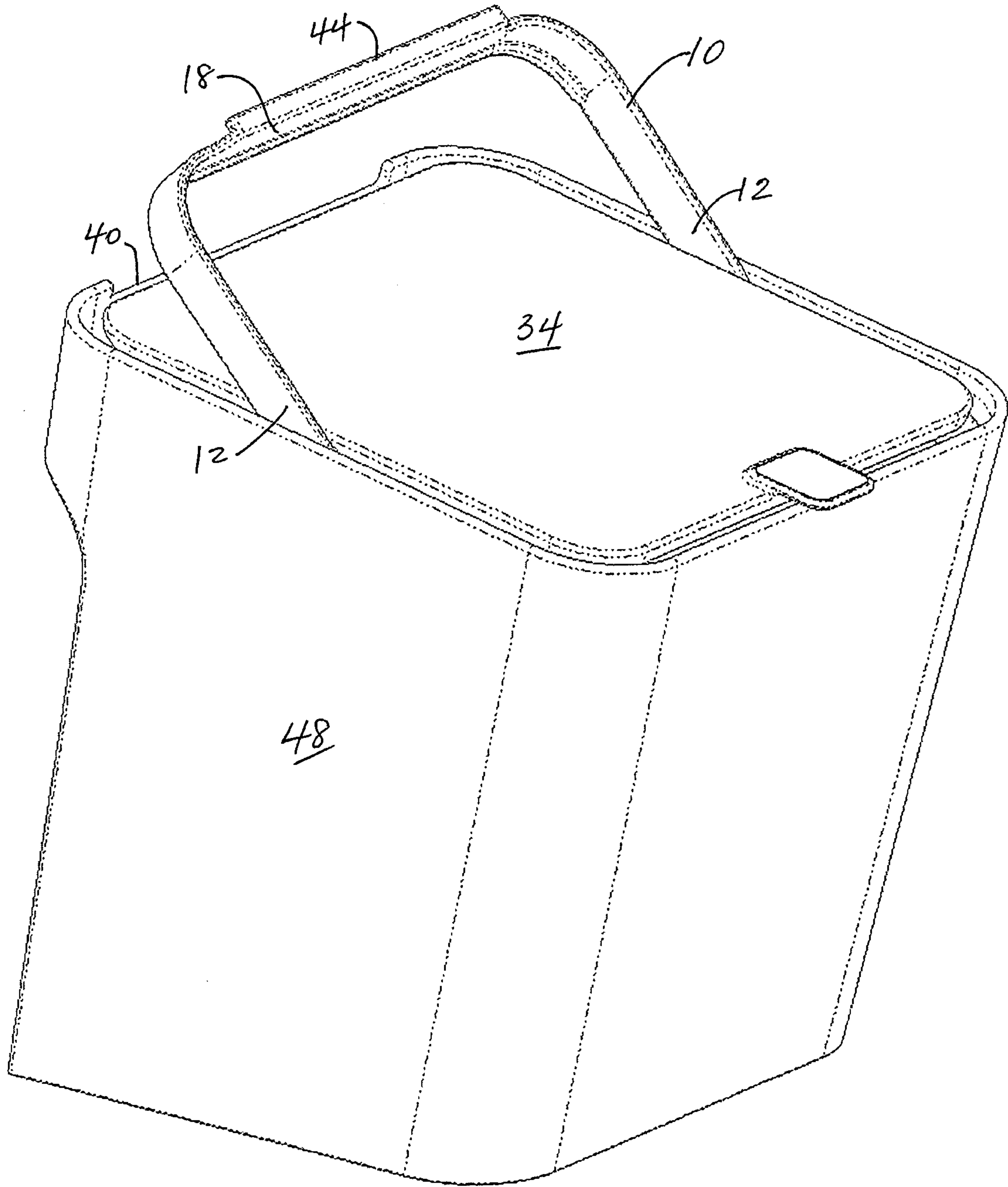

Fig. 8



9/18

**Fig. 9**

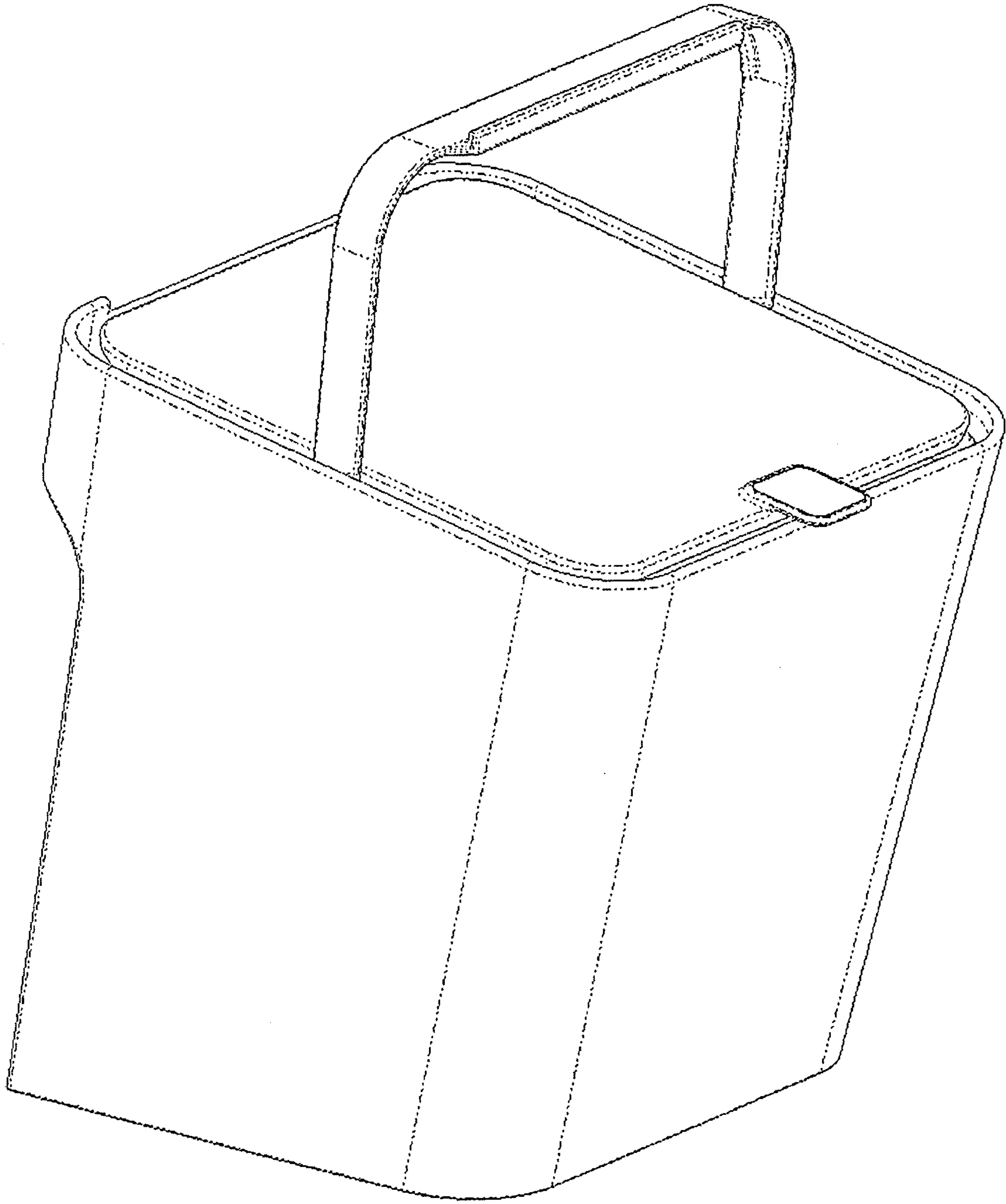

Fig. 10

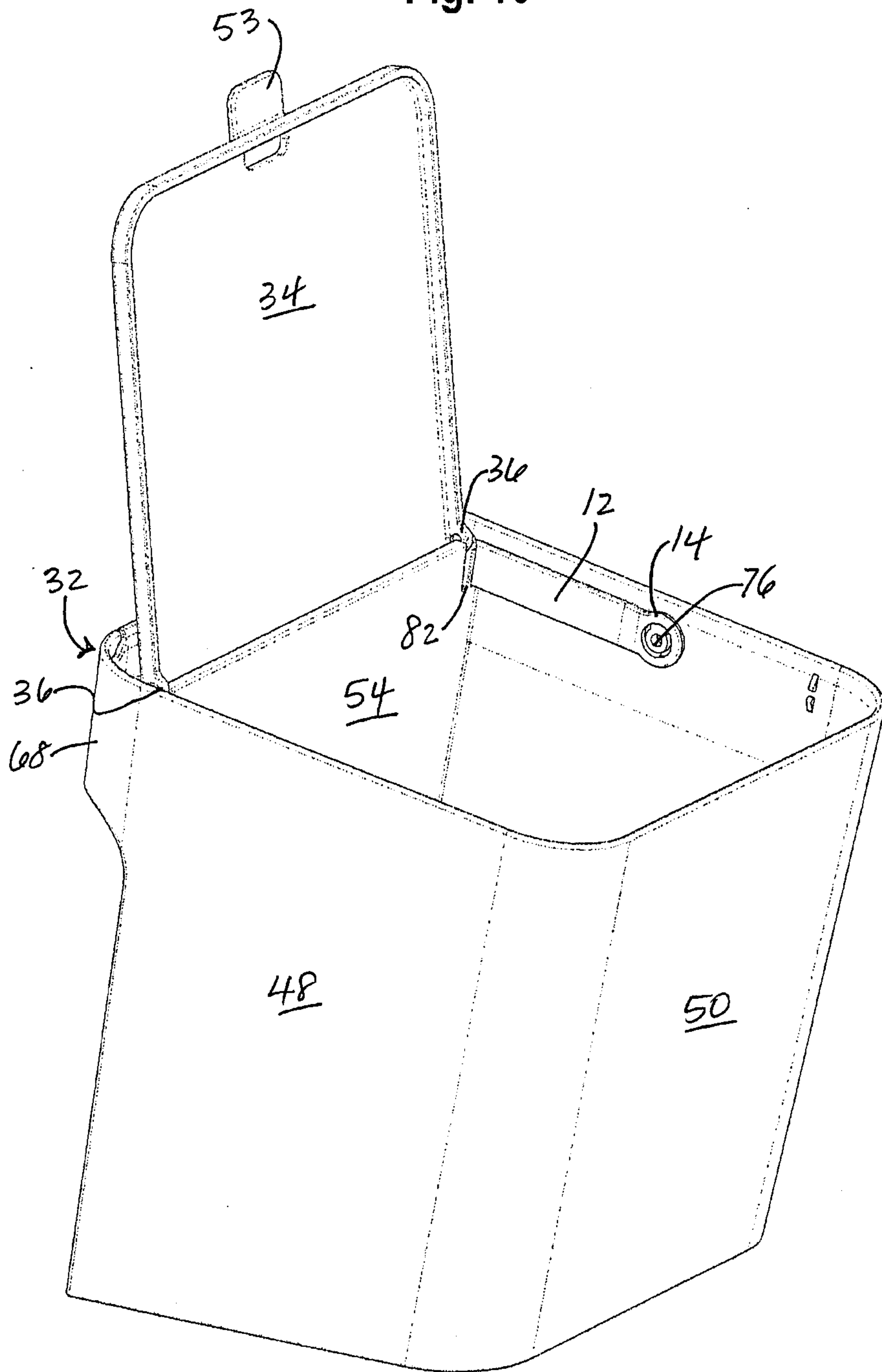

Fig. 11

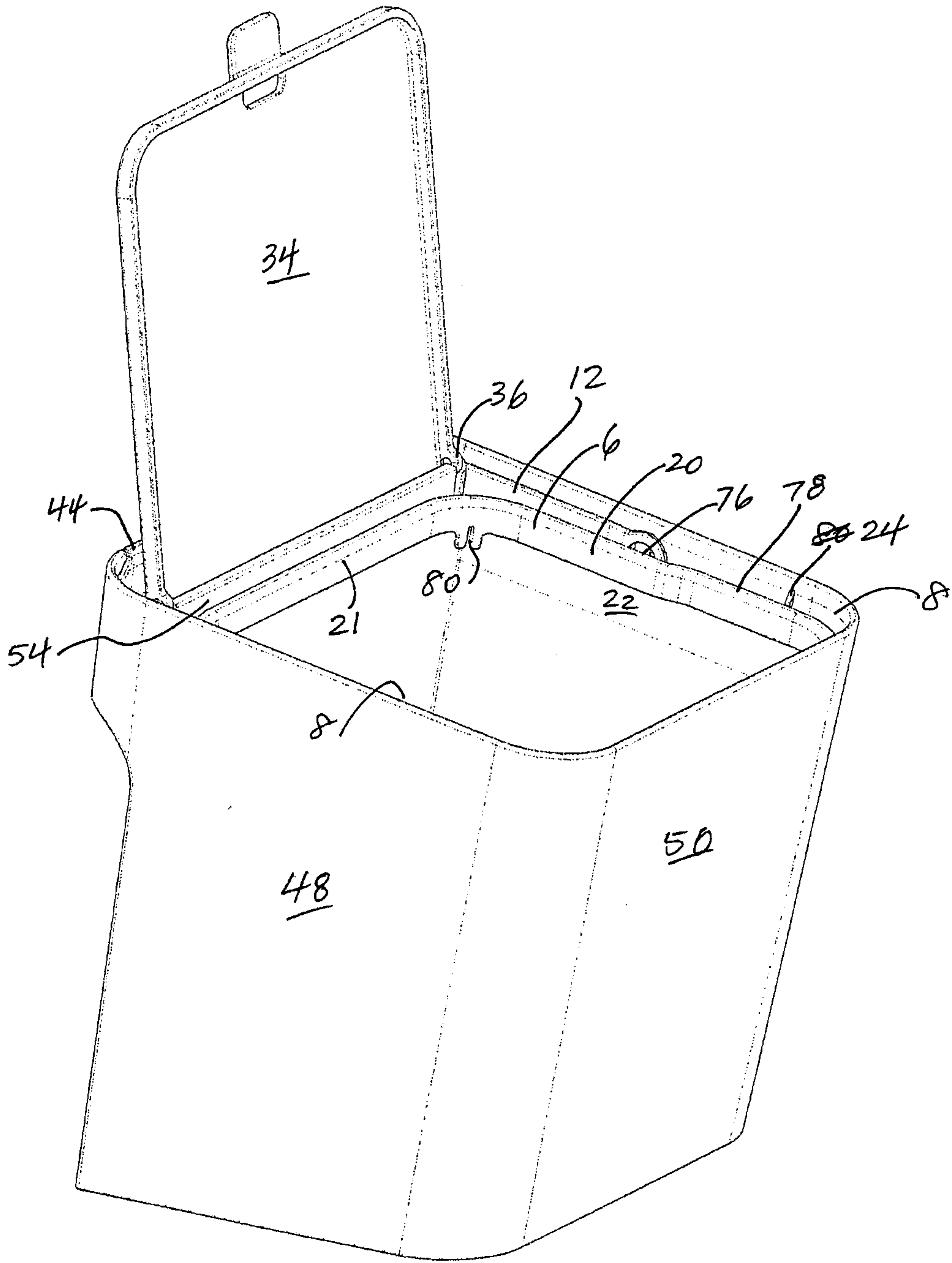
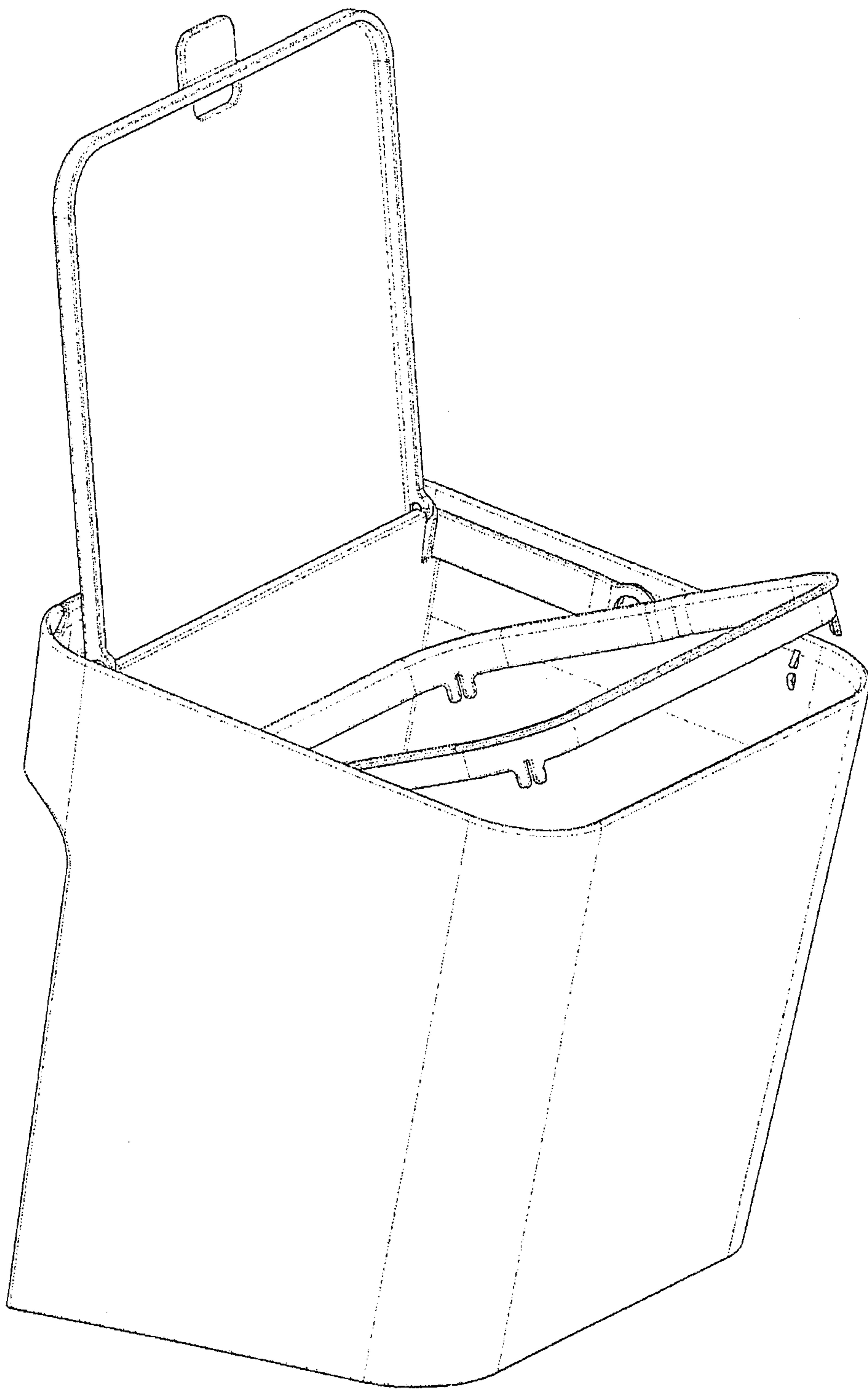

Fig. 12



**Fig. 13**

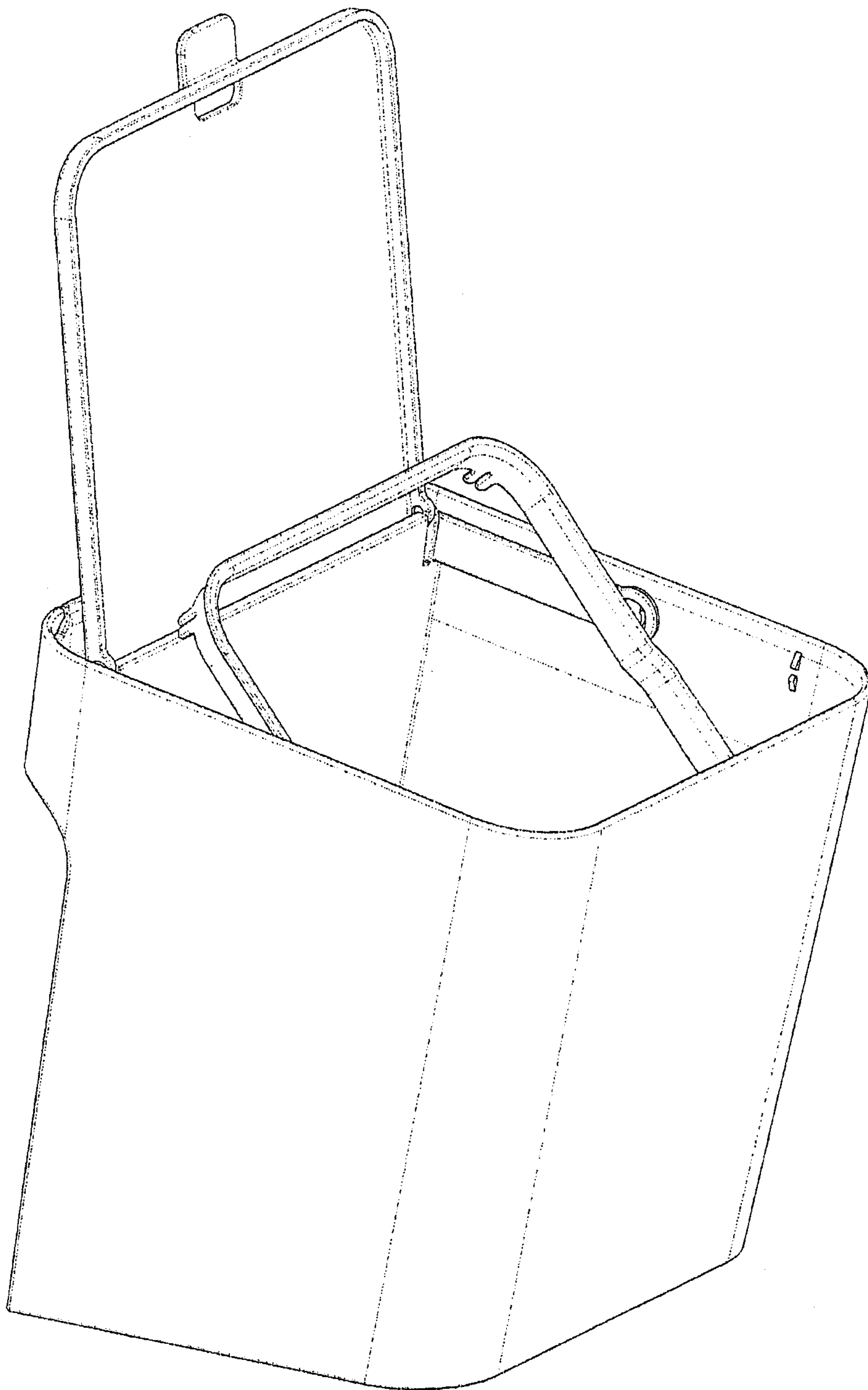
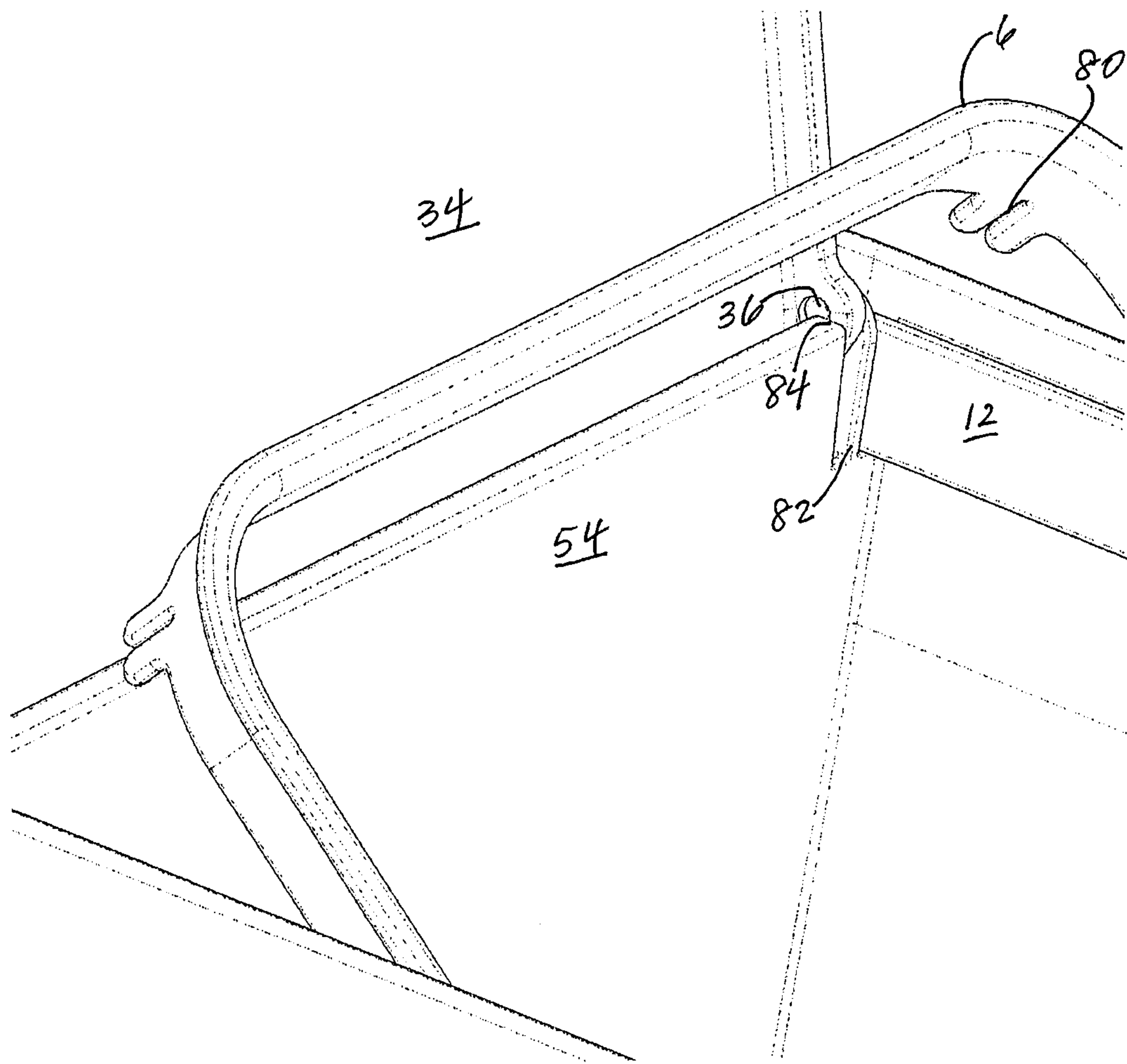
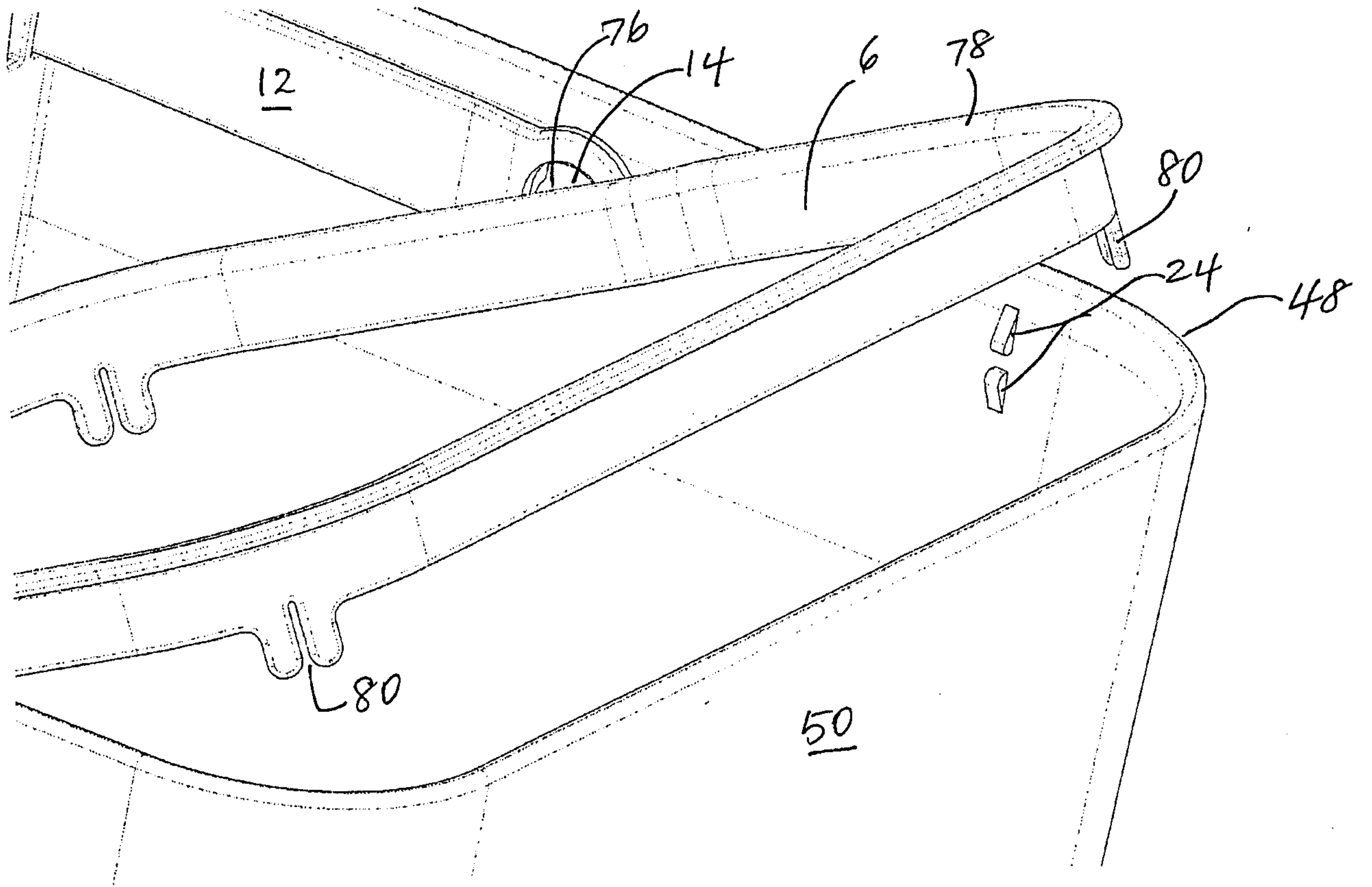

Fig. 14



**Fig. 15**



16/18

Fig. 17

~~8,595~~

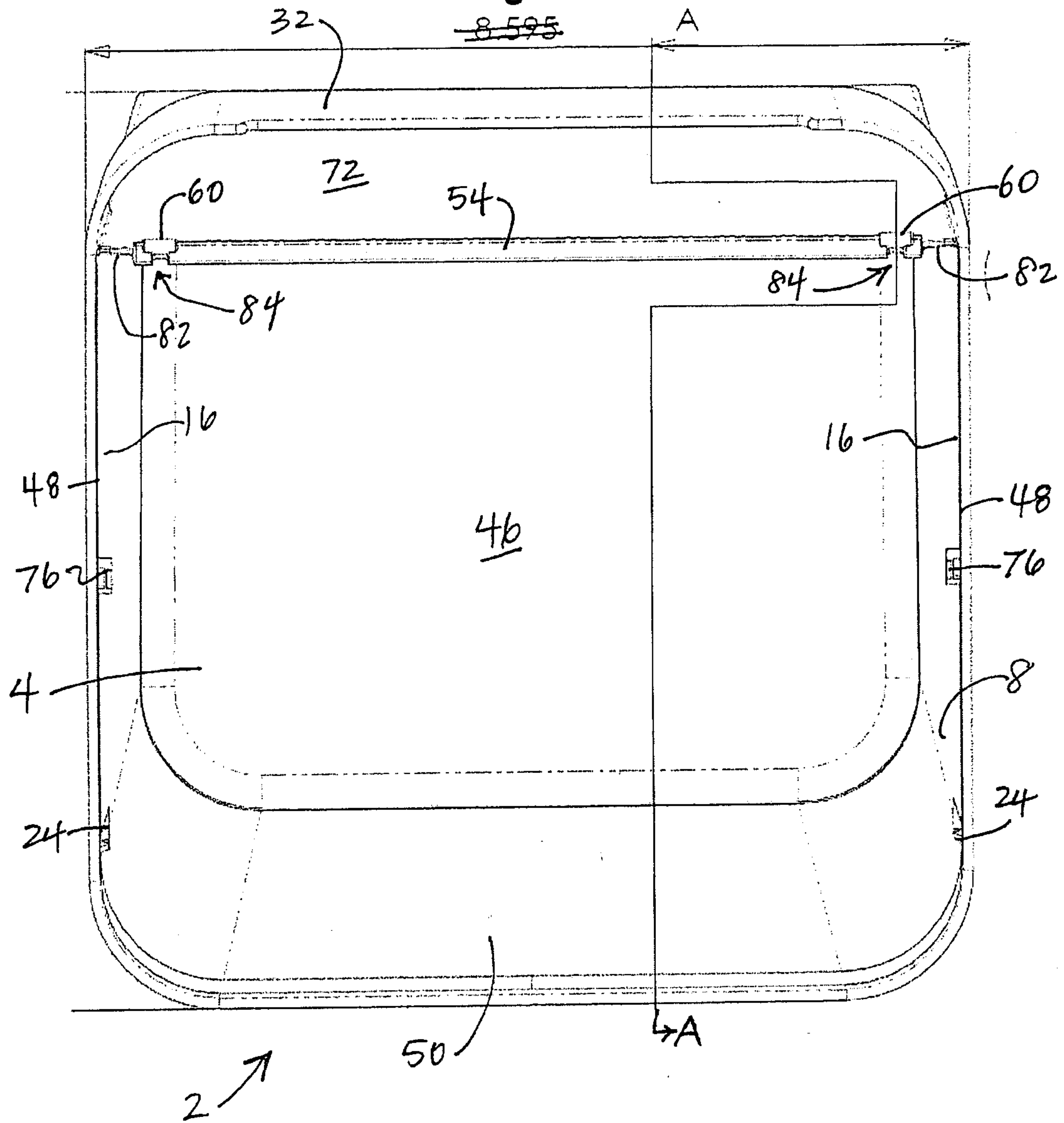

Fig. 18

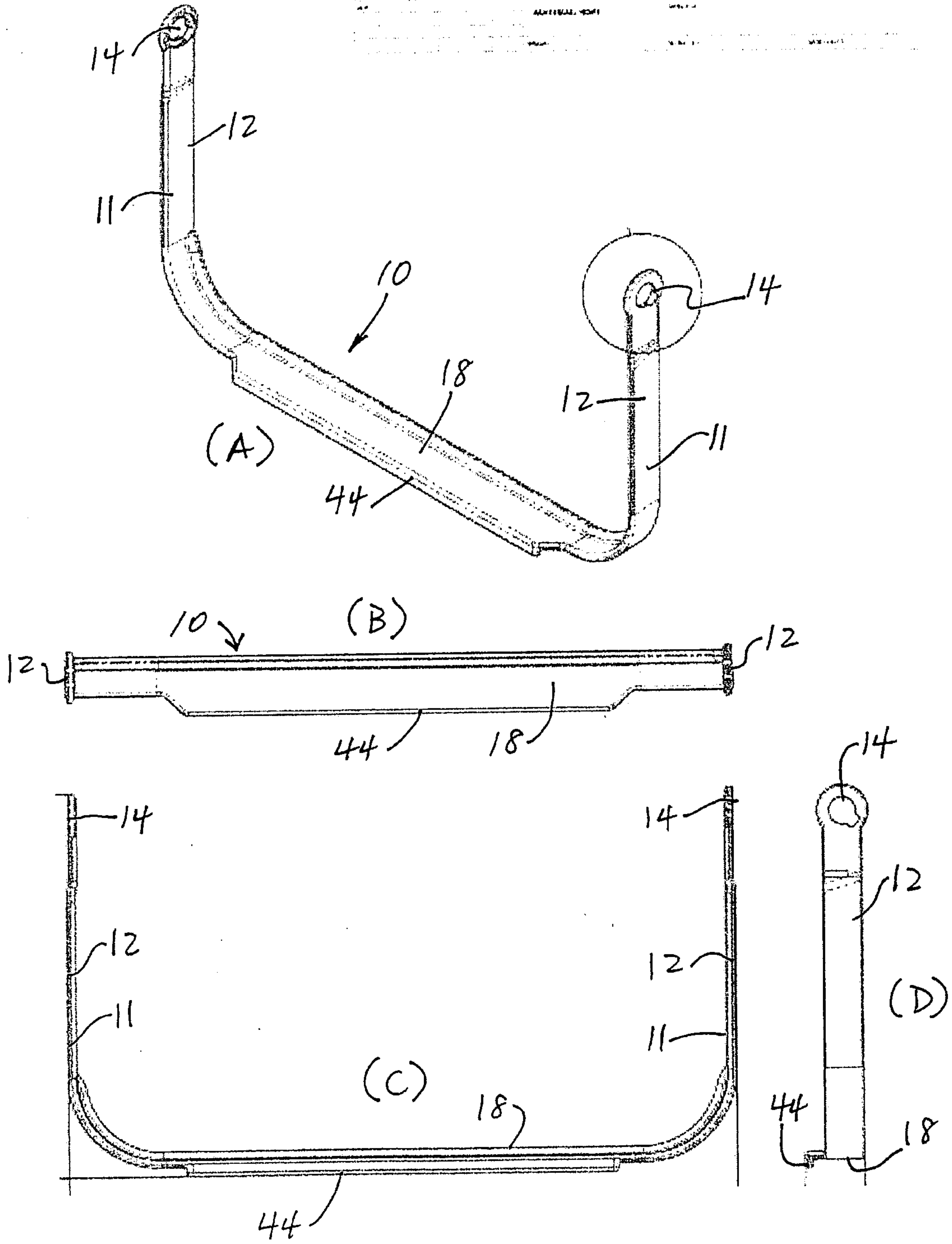

Fig. 19

