

(19)



(11)

**EP 2 481 879 B1**

(12)

**EUROPEAN PATENT SPECIFICATION**

(45) Date of publication and mention of the grant of the patent:  
**14.06.2017 Bulletin 2017/24**

(51) Int Cl.:  
**E06B 11/02<sup>(2006.01)</sup> E06B 3/964<sup>(2006.01)</sup>**

(21) Application number: **12152574.5**

(22) Date of filing: **26.01.2012**

(54) **Bar for a gate and method for manufacturing a gate**

Stab für ein Tor und Verfahren zur Herstellung eines Tors

Barre de porte et procédé de fabrication d'une porte

(84) Designated Contracting States:  
**AL AT BE BG CH CY CZ DE DK EE ES FI FR GB GR HR HU IE IS IT LI LT LU LV MC MK MT NL NO PL PT RO RS SE SI SK SM TR**

(30) Priority: **28.01.2011 NL 2006096**

(43) Date of publication of application:  
**01.08.2012 Bulletin 2012/31**

(73) Proprietor: **Heras B.V.**  
**5688 ZG Oirschot (NL)**

(72) Inventor: **Ruigrok, Jan Rudolf**  
**2631 LC Eindhoven (NL)**

(74) Representative: **D'Halleweyn, Nele Veerle Trees Gertrudis et al**  
**Arnold & Siedsma**  
**Bezuidenhoutseweg 57**  
**2594 AC The Hague (NL)**

(56) References cited:  
**GB-A- 2 408 064 NL-A- 8 302 007**  
**NL-C2- 2 000 880**

**EP 2 481 879 B1**

Note: Within nine months of the publication of the mention of the grant of the European patent in the European Patent Bulletin, any person may give notice to the European Patent Office of opposition to that patent, in accordance with the Implementing Regulations. Notice of opposition shall not be deemed to have been filed until the opposition fee has been paid. (Art. 99(1) European Patent Convention).

## Description

**[0001]** The present invention relates to an assembly according to the preamble of claim 1. The Netherlands patent 2000880 C2 in the name of the Applicant discloses a bar provided with a transverse channel for receiving a tensioning element, and provided with recesses for receiving a flange of the upper/lower beam.

**[0002]** Said document NL 2 000 880 C2 discloses all the features of the preamble of claims 1 and 10. Another bar is known from the Netherlands patent 8302007 in the name of applicant. Such a bar is used to make a gate element by providing a substantially horizontal beam with a plurality of bars which are mutually connected by means of a tensioning element, which is in turn connected to a substantially vertical post. The tensioning element is for instance a stiff steel wire or other slender element which is able to absorb tensile forces.

**[0003]** It is a drawback of the bars of the described type that threading the bars together is labour-intensive. This is because two persons are in principle required to perform the threading. A first person places the bars vertically with one outer end into the beam and subsequently rotates the bar in the correct direction to receive the tensioning element, while a second person pushes the tensioning element slowly forward so as to insert it into the transverse channel of the bar that has just been placed. The first person must here have a view of the location where the tensioning element is being threaded through the bar in order to slightly change the orientation of the bar if necessary so that the transverse channel comes to lie wholly parallel to the vertical plane of the gate element to be erected.

**[0004]** It is an object of the present invention to provide an assembly comprising at least one beam of a gate, a tensioning element for tensioning the gate, and a plurality of bars of the above described type with which a gate element can be assembled in less labour-intensive manner, in particular by one person.

**[0005]** The object is achieved with an assembly according to claim 1.

**[0006]** Since the person placing the bars in the beam can thus be sure that the bars are correctly oriented for receiving the tensioning element, the bar according to the present invention allows a less labour-intensive assembly of the gate element, wherein a single person places the bars successively in the beam at the correct orientation and subsequently threads the tensioning element in one operation through the transverse channels of the respective bars.

**[0007]** In an embodiment of the bar of the present invention the orienting element has at least one peripheral protrusion which, relative to a longitudinal axis of the bar, forms a predetermined angle with the direction of the transverse channel, this predetermined angle corresponding to an angle between a recess in the beam, which can be coupled to the protrusion, and a longitudinal axis of the beam.

**[0008]** It is an advantage of this embodiment that during coupling of the bar to the beam the correct orientation of the bar is easily detected by fitting the protrusion on the edge of the outer end of the bar into the recess of the beam provided for this purpose.

**[0009]** In a more specific embodiment the orienting element comprises two peripheral protrusions lying diametrically opposite each other. This embodiment is particularly advantageous when the bars provided with a transverse channel are rotation-symmetrical in a rotation angle of 180°.

**[0010]** In an embodiment of a bar according to the present invention the predetermined angle of the orienting element with the direction of the transverse channel is corresponding to an angle between a protrusion in the beam, which can be coupled to the recess, and a longitudinal axis of the beam. This embodiment has the same advantages as the above stated embodiment with a peripheral protrusion, with the understanding that the function of the recess and that of the protrusion are now interchanged. In a specific embodiment the orienting element comprises two peripheral recesses lying diametrically opposite each other. This embodiment also makes use of the 180° rotation-symmetry of the bar with a transverse channel. It is moreover advantageous in this embodiment that the bar must be rotated through a maximum of 180° in order to arrive at the correct orientation, while in the case of a bar with only one recess this may be 360°.

**[0011]** In an embodiment of the bar according to the present invention the recess is substantially L-shaped or stepped. This embodiment has the advantage that the bar is also locked vertically to certain extent and that, during placing of the bar in the beam, it is readily possible to discern when it has fully reached the correct orientation.

**[0012]** In an embodiment the recess has a widened entry side.

**[0013]** This embodiment has the advantage that placing of a bar in the beam becomes easier.

**[0014]** According to an embodiment, the predetermined angle corresponds to an angle between a recessed portion, which is arranged in the beam and which substantially corresponds in shape to the support surface, and a longitudinal axis of the beam.

**[0015]** In this embodiment the recess in the bar typically has the form of a horizontal slot or a groove, and the bar is rotated during placing such that the upper side of the slot or groove fits precisely into the recessed portion of the beam. In this configuration the slot or groove receives a portion of the beam (which is plate-like or hollow) so that the support surface gives the bar support, i. e. prevents further downward movement of the bar, while the immobilizing surface retains the bar when the bar is subjected to a tensile force from above.

**[0016]** The present invention also relates to an assembly comprising a beam for use with the above described bar, wherein an upper surface of the beam is provided

with a recessed portion substantially corresponding in shape to the support surface of the bar.

**[0017]** The present invention also relates to a method for manufacturing a gate according to claims 10 and 12. The method for manufacturing a gate comprises coupling a plurality of bars with a transverse channel to a beam and threading a tensioning element through the transverse channel of each of the bars, wherein coupling of the plurality of bars with the transverse channel to the beam takes place at an angular orientation which is determined by fitting protrusions into recesses, wherein the plurality of bars are provided with the recesses and the beam is provided with the protrusions.

**[0018]** The method may comprise coupling a plurality of bars of the above described type to a beam of the above described type and threading a tensioning element through the transverse channel of each of the bars, wherein coupling of the plurality of bars to the beam takes place at an angular orientation determined by fitting the support surface of each bar into the corresponding recessed portion of the beam.

**[0019]** The present invention also relates to an assembly comprising at least one beam and a plurality of bars as described above.

**[0020]** In an embodiment the assembly according to the present invention is further provided with a tensioning element.

**[0021]** In a specific embodiment the tensioning element comprises a steel rod.

**[0022]** The present invention also relates to a gate comprising the above described assembly.

**[0023]** In an embodiment of the method according to the present invention the recesses are substantially L-shaped or stepped, and coupling of each of the plurality of bars to the beam comprises of rotating each of the plurality of bars around their respective longitudinal axis.

**[0024]** The foregoing aspects and advantages of the present invention will now be further elucidated with reference to the figures, wherein:

Figure 1 is an outline view of a bar gate;  
 Figure 2 illustrates the problems of the prior art;  
 Figure 3 shows a bar according to an embodiment of the present invention;  
 Figure 4 shows a bar according to another embodiment of the present invention;  
 Figure 5 shows a more specific embodiment;  
 Figure 6 is a partial enlargement of the outer end of a bar such as that in Figure 5;  
 Figure 7 shows a bar according to yet another embodiment of the present invention; and  
 Figure 8 shows a part of a beam according to the invention for use with the bar of Figure 6.

**[0025]** Figure 1 shows a known gate 1 formed by substantially vertical bars 100 placed between substantially horizontal beams 120, 121. The shown gate element is supported by vertical posts. In order to strengthen the

gate element the bars 100 are connected to each other by a tensioning element (not shown) threaded through a transverse channel of bars 100. The tensioning element is attached to the vertical post, optionally via a hinge and/or other connecting part. In the embodiment of Figure 1 the tensioning element and the transverse channels are inside the substantially hollow beam 120.

**[0026]** Figure 2 illustrates the difficulty which occurs during assembly of a known bar gate such as that shown in Figure 1. Since the zone in which the transverse channels of bars 100 are located is inside the substantially hollow horizontal beam 120, it is very difficult to see whether the placed bars have the correct orientation. Two people are in fact therefore required to assemble such a known gate element, wherein the first looks via small openings at the otherwise covered outer end of the bar 100 to be fitted and rotates the bar 100 until the correct orientation is reached, and the second pushes the tensioning element 140 through the correctly oriented transverse channels. During the assembly a temporary positioning beam 122 can be used to hold the placed bars 100 at the correct height during threading, this positioning beam 122 being removed after proper anchoring of tensioning element 140.

**[0027]** Figure 3 shows a bar 100 according to the present invention provided with a transverse channel 130 suitable for receiving a tensioning element 140. Tensioning element 140 here also has the purpose of threading together different bars and of attaching the whole to the substantially vertical posts bounding the gate element. Tensioning element 140 can be a steel wire or other suitable slender element with sufficient stiffness. The shown bar 100 has on at least one outer end 110 (only the lower outer end is shown here) an orienting means 151 which consists in the shown embodiment of two recesses lying diametrically opposite each other. These recesses 151 are formed in each case such that, at a correct orientation of the bar, they fit precisely into the corresponding protrusions 161 provided for this purpose in beam 120.

**[0028]** It is in principle also possible to provide a single recess 151 and a single protrusion 161 or to provide a certain larger number of recesses 151 and the same number of protrusions 161. Because both the recesses and the protrusions are placed in the shown exemplary embodiment in diametrically opposite pairs, two equivalent orientations are possible, both corresponding to the situation in which the transverse channel 130 runs parallel to the longitudinal axis of beam 120, and in which threading together of the bars is thus possible. The maximum rotation which has to be performed in order to arrive at a correct orientation is thus halved compared to an embodiment with only one recess 151 and one protrusion 161, this further increasing ease of assembly.

**[0029]** Figure 4 shows a variant of the bar according to the present invention wherein recess 151 in a hollow bar 100 takes the form of a slot. In order to facilitate assembly this slot has a somewhat widened entry side. This embodiment otherwise has the same operation and fea-

tures as the above described embodiment of Figure 3.

**[0030]** In the embodiments of Figures 3 and 4 the bar **100** is provided in each case with a recess **151** while beam **120** is provided with a protrusion **161**. The orienting effect can however also be obtained by providing beam **120** with a recess and providing bar **100** with a protrusion.

**[0031]** The shown embodiments have the advantage that, due to the contact between the upper outer end of recesses **151** and protrusions **161**, bar **100** finds support on these protrusions **161** and so will not drop through beam **120**, even if this latter takes a substantially hollow form or if the opening in which bar **100** is placed passes through the whole of beam **120**. Compared to the prior art method as shown in Figure 2, the positioning beam **122** can on the one hand be dispensed with and the load on tensioning element **140** can on the other be greatly reduced.

**[0032]** Figure 5 shows a further variant of the bar according to the present invention, wherein recess **151** in outer end **110** of bar **100** is L-shaped or even stepped. This variant has the advantage that the placing of the bar in the beam takes place with a bayonet coupling, thereby obtaining both rotational and translational locking of the bar in the beam. This makes it even easier for the person placing the bars in the beam to make sure that the bar has reached the correct orientation. Furthermore, it is not possible after assembly to pull the bars upward out of the beam.

**[0033]** Figure 6 shows a partial enlargement of the outer end of a bar **100** of the type shown in Figure 5. Shown in Figure 6 is an optional additional recessed portion **159** which secures the bar against rotation following assembly.

**[0034]** Figure 7 shows a further variant of the bar according to the present invention, wherein bar **100** has a square profile with rounded ribs **170**. The flat or hollow beam **120** has a corresponding opening. The orienting element is formed by a set of horizontal slots **152** which, at a correct orientation of bar **100**, find support on the upper side of beam **120**. Particularly the upper side of slots **152** forms a support surface **180** which, at a correct orientation, fits precisely into a recessed portion (not shown) arranged for this purpose in beam **120**. The underside of slots **152** forms an immobilizing surface **190** which retains the mounted bar **100** if a tensile force were to be exerted on bar **100** from above.

**[0035]** Figure 8 shows the corresponding beam **120**, wherein the recessed portions **162** for receiving the support surfaces **180** are clearly shown.

**[0036]** Although the invention has been described above on the basis of specific embodiments, these serve only to elucidate and not to limit the invention. The skilled person will appreciate that measures and features of the invention described in the context of one embodiment can be applied in the context of other embodiments without departing from the scope of the invention.

## Claims

1. Assembly comprising at least one beam (120) of a gate, a tensioning element (140) for tensioning the gate, and a plurality of bars, each bar having at least one outer end (110) for use with the beam (120), the bar being provided with a transverse channel (130) for receiving the tensioning element, wherein the at least one outer end (110) is further provided with an orienting element (151, 152) adapted to ensure a substantially parallel orientation of the transverse channel (130) and the beam (120) during coupling of the bar (100) to the beam (120); **characterized in that** the orienting element comprises at least one peripheral recess (151, 152) which, relative to a longitudinal axis of the bar (100), forms a predetermined angle with the direction of the transverse channel (130), wherein the at least one peripheral recess (151, 152) is formed such that a lower surface of a part of the bar (100) adjacent at the top to the recess forms a support surface (180) for preventing further downward movement of the bar.
2. Assembly according to claim 1, wherein the predetermined angle corresponds to an angle between a recessed portion (162), which is arranged in the beam (120) and which substantially corresponds in shape to the support surface, and a longitudinal axis of the beam (120).
3. Assembly as claimed in claim 1 or 2, wherein the orienting element comprises two peripheral recesses (151) lying diametrically opposite each other.
4. Assembly (100) as claimed in any of the claims 1-3, wherein the recess (151) is substantially L-shaped or stepped.
5. Assembly as claimed in any of the claims 1 to 4, wherein the recess (151) has a widened entry side.
6. Assembly as claimed in any of the claims 1 to 5, wherein the at least one peripheral recess (152) is further provided with an additional recess (159) securing the bar (100) against rotation following assembly.
7. Assembly as claimed in any of the claims 1 to 6, wherein an upper surface (121) of the beam (120) is provided with a recessed portion (162) substantially corresponding in shape to the support surface (180) of the bar (100).
8. Assembly as claimed in any one of the previous claims, wherein the tensioning element (140) comprises a steel rod.

9. Gate (1) comprising the assembly as claimed in any of the claims 1 to 8.

10. Method for manufacturing a gate (1), comprising of:

- coupling a plurality of bars (100) with a transverse channel (130) to a beam (120), and
- threading a tensioning element (140) through the transverse channel (130) of each of the bars (100),

wherein coupling of the plurality of bars (100) with the transverse channel (130) to the beam (120) takes place at an angular orientation which is determined by fitting protrusions into recesses (151, 152); wherein the plurality of bars (100) are provided with the recesses (151) and the beam is provided with the protrusions (161);

**characterized in that** the recesses (151, 152) are formed such that a lower surface of a part of the bar adjacent at a top to the recess forms a support surface and an upper surface of a part adjacent at the bottom to the recess forms an immobilizing surface.

11. Method as claimed in claim 10, wherein the recesses (151) are substantially L-shaped or stepped, and wherein coupling of each of the plurality of bars (100) to the beam (120) comprises of rotating each of the plurality of bars around their respective longitudinal axis.

12. Method for manufacturing a gate (1), comprising of:

- coupling a plurality of bars (100) of an assembly according to claim 2 to a beam (120) of an assembly according to claim 7, and
- threading a tensioning element (140) through the transverse channel (130) of each of the bars (100),

wherein coupling of the plurality of bars (100) to the beam (120) takes place at an angular orientation determined by fitting the support surface of each bar (100) into the corresponding recessed portion (162) of the beam (120).

## Patentansprüche

1. Einrichtung, aufweisend mindestens einen Träger (120) eines Tors, ein Spannelement (140) zum Verspannen des Tors, und eine Mehrzahl von Stäben, wobei jeder Stab mindestens ein äußeres Ende (110) zur Verwendung mit dem Träger (120) aufweist, wobei der Stab mit einem transversalen Kanal (130) zum Aufnehmen des Spannelements versehen ist, wobei das mindestens eine äußere Ende (110) fer-

ner versehen ist mit einem Ausrichtungselement (151, 152), welches dazu eingerichtet ist, eine im Wesentlichen parallele Ausrichtung des transversalen Kanals (130) und des Trägers (120) beim Verbinden des Stabs (100) mit dem Träger (120) sicherzustellen, **gekennzeichnet dadurch, dass** das Ausrichtungselement mindestens eine periphere Aussparung (151, 152) aufweist, welche relativ zu einer Längsachse des Stabs (100) einen vorbestimmten Winkel mit der Richtung des transversalen Kanals (130) bildet, wobei die mindestens eine periphere Aussparung (151, 152) ausgebildet ist, so dass eine untere Fläche eines Teils des Stabs (100), der an der Oberseite zu der Aussparung benachbart ist, eine Stützfläche (180) zum Verhindern einer weiteren Abwärtsbewegung des Stabs bildet.

2. Einrichtung gemäß Anspruch 1, wobei der vorbestimmte Winkel mit einem Winkel zwischen einem ausgesparten Abschnitt (162), der in dem Träger (120) angeordnet ist und der hinsichtlich Form im Wesentlichen mit der Stützfläche korrespondiert, und einer Längsachse des Trägers (120) korrespondiert.

3. Einrichtung wie in Anspruch 1 oder 2 beansprucht, wobei das Ausrichtungselement zwei periphere Aussparungen (151), die einander diametral gegenüber liegen, aufweist.

4. Einrichtung (100) wie in irgendeinem der Ansprüche 1-3 beansprucht, wobei die Aussparung (151) im Wesentlichen L-förmig oder gestuft ist.

5. Einrichtung wie in irgendeinem der Ansprüche 1 bis 4 beansprucht, wobei die Aussparung (151) eine geweitete Eintrittsseite hat.

6. Einrichtung wie in irgendeinem der Ansprüche 1 bis 5 beansprucht, wobei die wenigstens eine periphere Aussparung (152) ferner mit einer zusätzlichen Aussparung (159) versehen ist, welche den Stab (100) gegen eine auf die Montage folgende Rotation sichert.

7. Einrichtung wie in irgendeinem der Ansprüche 1 bis 6 beansprucht, wobei eine obere Fläche (121) des Trägers (120) mit einem ausgesparten Abschnitt (162) versehen ist, der hinsichtlich Form im Wesentlichen mit der Stützfläche (180) des Stabs (100) korrespondiert.

8. Einrichtung wie in irgendeinem der vorherigen Ansprüche beansprucht, wobei das Spannelement (140) eine Stahllange aufweist.

9. Tor (1), aufweisend die Einrichtung wie in irgendeinem der vorherigen Ansprüche 1 bis 8 beansprucht.

10. Verfahren zum Herstellen eines Tors (1), aufweisend:

- Verbinden einer Mehrzahl von Stäben (100), die einen transversalen Kanal (130) aufweisen, mit einem Träger (120), und
- Hindurchführen eines Spannelements (140) durch den transversalen Kanal (130) jedes Stabs (100),

wobei das Verbinden der Mehrzahl von Stäben (100), die den transversalen Kanal (130) aufweisen, mit dem Träger (120) bei einer Winkelausrichtung, welche durch Einbringen von Vorsprüngen in Aussparungen (151, 152) festgelegt ist, stattfindet, wobei die Mehrzahl von Stäben (100) mit den Aussparungen (151) versehen ist und wobei der Träger mit den Vorsprüngen (161) versehen ist, **gekennzeichnet dadurch, dass** die Aussparungen (151, 152) ausgebildet sind, so dass eine untere Fläche eines Teils des Stabs, der an der Oberseite zu der Aussparung benachbart ist, eine Stützfläche bildet und dass eine obere Fläche eines Teils, der an der Unterseite zu der Aussparung benachbart ist, eine Festhaltefläche bildet.

11. Verfahren wie in Anspruch 10 beansprucht, wobei die Aussparungen (151) im Wesentlichen L-förmig oder gestuft sind, und wobei das Verbinden jedes von der Mehrzahl von Stäben (100) mit dem Träger (120) ein Rotieren jedes der Mehrzahl von Stäben um ihre jeweilige Längsachse aufweist.

12. Verfahren zum Herstellen eines Tors (1), aufweisend:

- Verbinden einer Mehrzahl von Stäben (100) einer Einrichtung gemäß Anspruch 2 mit einem Träger (120) einer Einrichtung gemäß Anspruch 7, und
- Hindurchführen eines Spannelements (140) durch den transversalen Kanal (130) jedes Stab (100),

wobei das Verbinden der Mehrzahl von Stäben (100), die den transversalen Kanal (130) aufweisen, mit dem Träger (120) bei einer Winkelausrichtung, welche durch Einbringen der Stützfläche jedes Stabs (100) in die korrespondierenden ausgesparten Abschnitte (162) des Trägers festgelegt ist, stattfindet.

## Revendications

1. Ensemble comprenant au moins une traverse (120) d'une porte, un élément d'application de tension (140) destiné à appliquer une tension sur la porte,

et une pluralité de barres, chaque barre comportant au moins une extrémité externe (110) destinée à être utilisée avec la traverse (120), la barre comportant un canal transversal (130) destiné à recevoir l'élément d'application de tension, dans lequel la ou les extrémités externes (110) comportent en outre un élément d'orientation (151, 152) adapté afin d'assurer une orientation sensiblement parallèle du canal transversal (130) et de la traverse (120) au cours du couplage de la barre (100) sur la traverse (120); **caractérisé en ce que** l'élément d'orientation comprend au moins une cavité périphérique (151, 152) qui, par rapport à un axe longitudinal de la barre (100), forme un angle prédéterminé avec la direction du canal transversal (130), dans lequel la ou les cavités périphériques (151, 152) sont formées, de telle sorte qu'une surface inférieure d'une partie de la barre (100) adjacente à la partie supérieure de la cavité forme une surface de support (180) destinée à empêcher tout autre mouvement descendant de la barre.

2. Ensemble selon la revendication 1, dans lequel l'angle prédéterminé correspond à un angle compris entre une partie en cavité (162), qui est agencée sur la traverse (120) et dont la forme correspond sensiblement à celle de la surface de support, et un axe longitudinal de la traverse (120).

3. Ensemble selon la revendication 1 ou 2, dans lequel l'élément d'orientation comprend deux cavités périphériques (151) agencées comme étant diamétralement à l'opposé l'une de l'autre.

4. Ensemble (100) selon l'une quelconque des revendications 1 à 3, dans lequel la cavité (151) est sensiblement en forme de L ou étagée.

5. Ensemble selon l'une quelconque des revendications 1 à 4, dans lequel la cavité (151) présente un côté d'entrée élargi.

6. Ensemble selon l'une quelconque des revendications 1 à 5, dans lequel la ou les cavités périphériques (152) comportent en outre une cavité supplémentaire (159) empêchant la rotation de la barre (100) après assemblage.

7. Ensemble selon l'une quelconque des revendications 1 à 6, dans lequel une surface supérieure (121) de la traverse (120) comporte une partie en cavité (162) dont la forme correspond sensiblement à celle de la surface de support (180) de la barre (100).

8. Ensemble selon l'une quelconque des revendications précédentes, dans lequel l'élément d'application de tension (140) comprend une tige en acier.

9. Porte (1) comprenant l'ensemble selon l'une quelconque des revendications 1 à 8.
10. Procédé de fabrication d'une porte (1), comprenant :
- le couplage d'une pluralité de barres (100) avec un canal transversal (130) à une traverse (120), et
  - l'enfilage d'un élément d'application de tension (140) à travers le canal transversal (130) de chacune des barres (100),
- dans lequel le couplage de la pluralité de barres (100) avec le canal transversal (130) à la traverse (120) est assuré sous une orientation angulaire qui est déterminée par des saillies d'assemblage dans les cavités (151, 152) ;
- dans lequel les barres de la pluralité de barres (100) comportent les cavités (151) et la traverse comporte les saillies (161) ;
- caractérisé en ce que** les cavités (151, 152) sont formées de telle sorte qu'une surface inférieure d'une partie de la barre adjacente à la cavité en haut forme une surface de soutien et une surface supérieure d'une partie adjacente à la cavité en bas forme une surface d'immobilisation.
11. Procédé selon la revendication 10, dans lequel les cavités (151) sont sensiblement en forme de L ou étagées, et dans lequel le couplage de chacune de la pluralité de barres (100) à la traverse (120) comprend la rotation de chacune de la pluralité de barres autour de leur axe longitudinal respectif.
12. Procédé de fabrication d'une porte (1), comprenant :
- le couplage d'une pluralité de barres (100) d'un ensemble selon la revendication 2 à une traverse (120) d'un ensemble selon la revendication 7, et
  - l'enfilage d'un élément d'application de tension (140) à travers le canal transversal (130) de chacune des barres (100),
- dans lequel le couplage de la pluralité de barres (100) à la traverse (120) est assuré sous une orientation angulaire déterminée par assemblage de la surface de support de chaque barre (100) dans la partie en cavité (162) correspondante de la traverse (120).

55

FIGURE 1

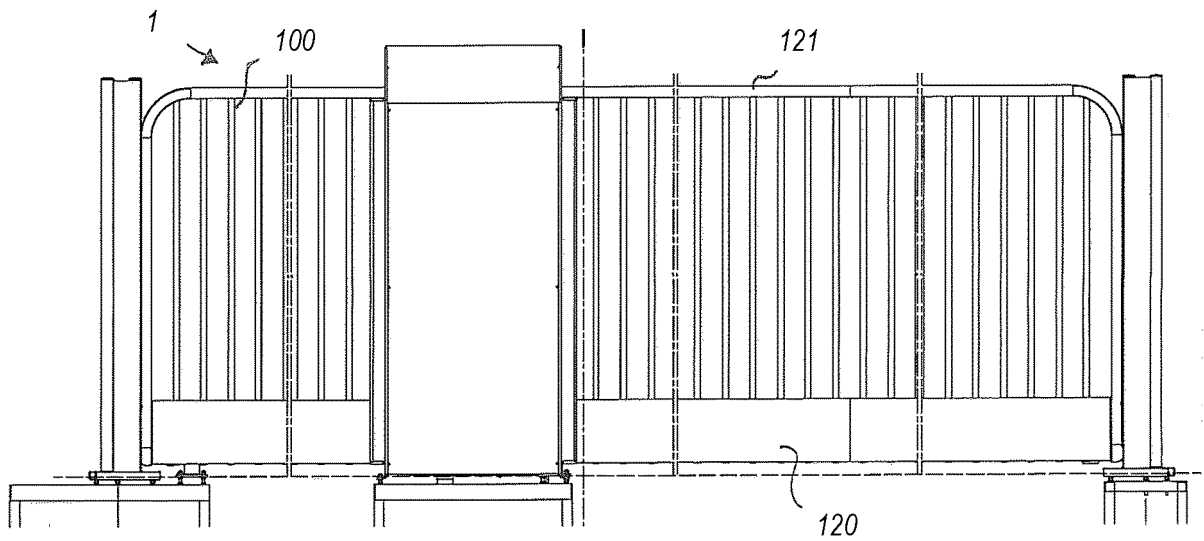

FIGURE 2

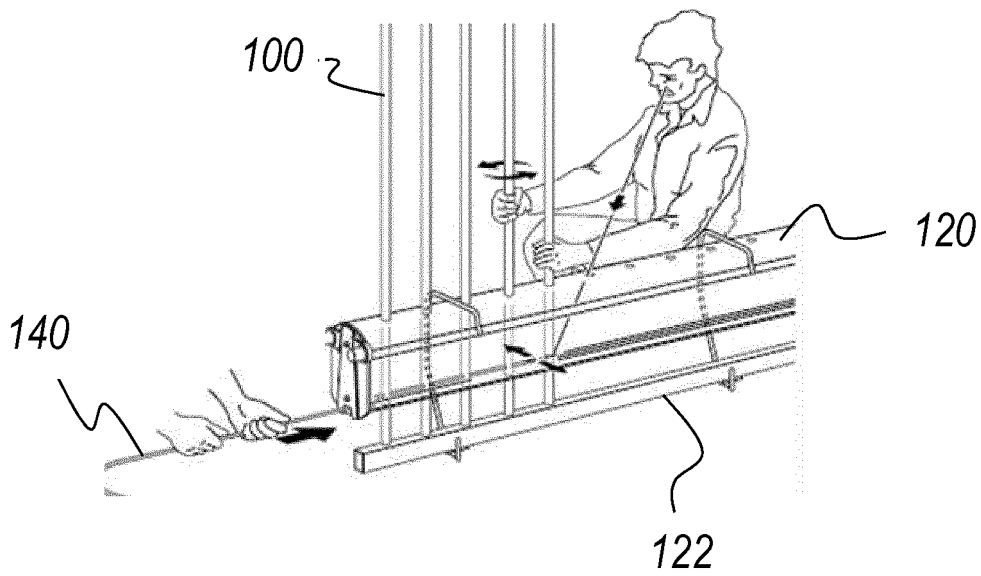

FIGURE 3

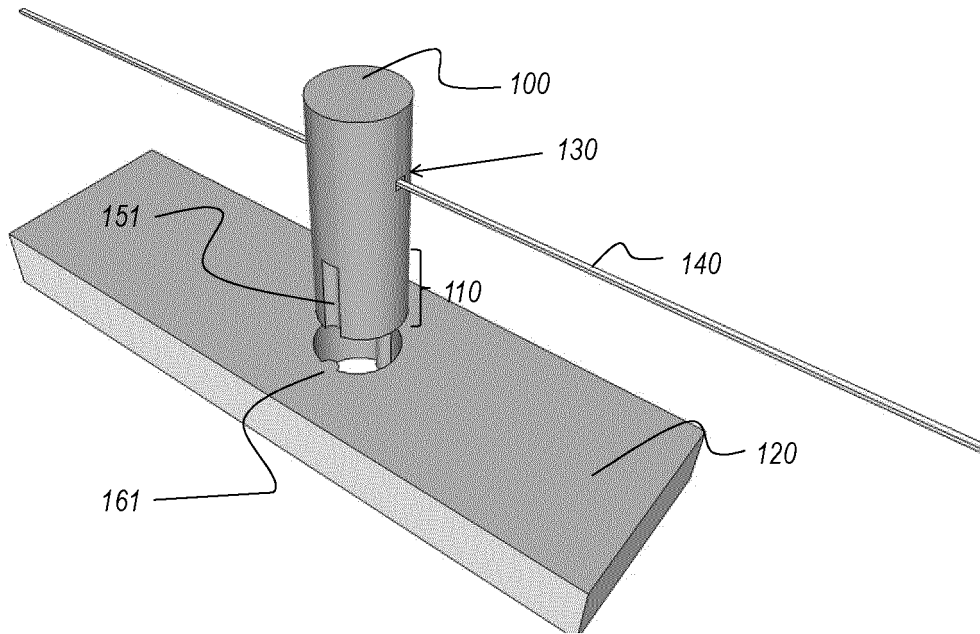

FIGURE 4

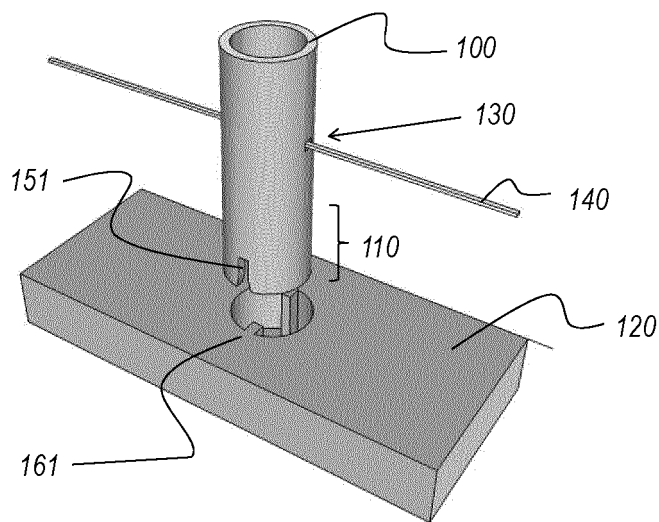

FIGURE 5

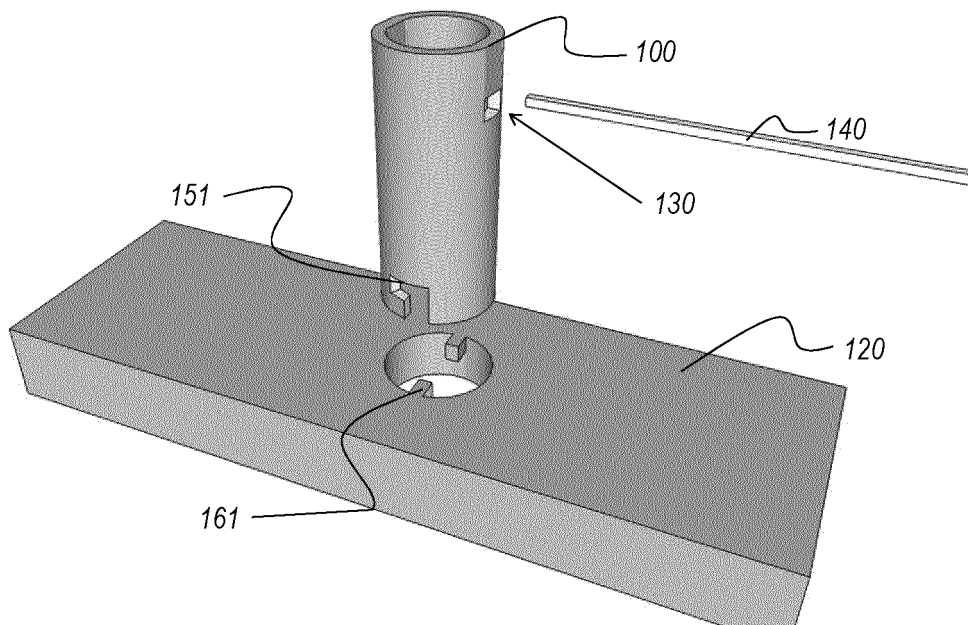

FIGURE 6

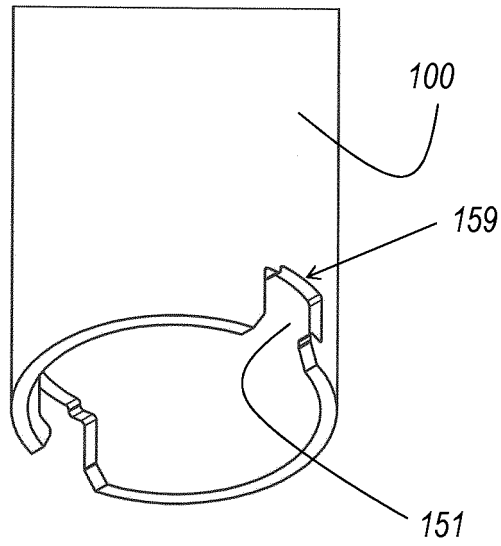

FIGURE 7

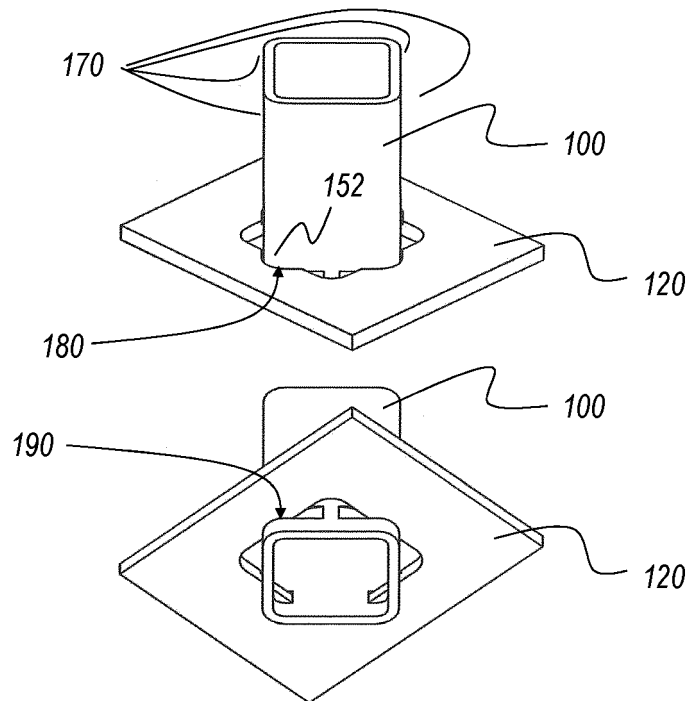
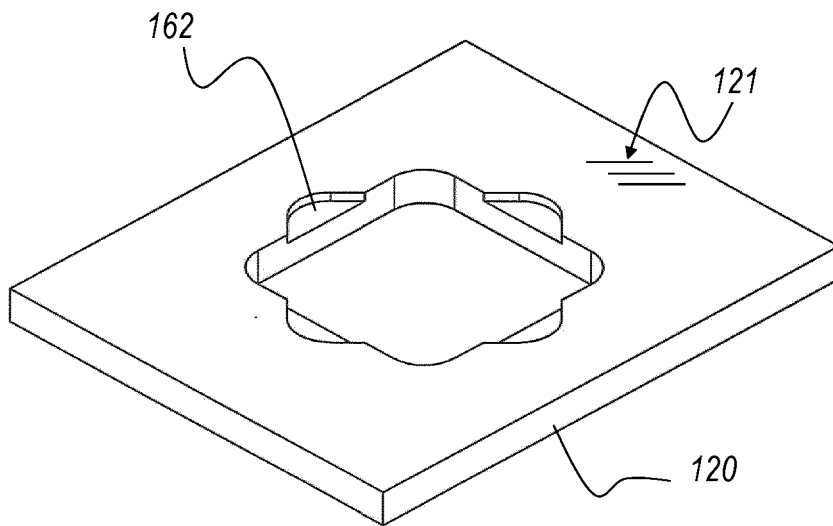

FIGURE 8



**REFERENCES CITED IN THE DESCRIPTION**

*This list of references cited by the applicant is for the reader's convenience only. It does not form part of the European patent document. Even though great care has been taken in compiling the references, errors or omissions cannot be excluded and the EPO disclaims all liability in this regard.*

**Patent documents cited in the description**

- NL 2000880 C2 [0001] [0002]
- NL 8302007 [0002]