

(12) STANDARD PATENT
(19) AUSTRALIAN PATENT OFFICE

(11) Application No. **AU 2006314365 B9**

(54) Title
Intervertebral disc prosthesis

(51) International Patent Classification(s)
A61F 2/44 (2006.01)

(21) Application No: **2006314365** (22) Date of Filing: **2006.11.14**

(87) WIPO No: **WO07/057555**

(30) Priority Data

(31) Number	(32) Date	(33) Country
05 11596	2005.11.16	FR

(43) Publication Date: **2007.05.24**

(44) Accepted Journal Date: **2010.07.15**

(48) Corrigenda Journal Date: **2010.07.22**

(71) Applicant(s)
Warsaw Orthopedic, Inc.

(72) Inventor(s)
Assaker, Richard;Pointillart, Vincent

(74) Agent / Attorney
FB Rice & Co, Level 23 44 Market Street, Sydney, NSW, 2000

(56) Related Art
US 2005/0165485 (TRIEU) 28 July 2005
US 6582466 (GAUCHET) 24 June 2003

(12) DEMANDE INTERNATIONALE PUBLIÉE EN VERTU DU TRAITÉ DE COOPÉRATION
EN MATIÈRE DE BREVETS (PCT)

(19) Organisation Mondiale de la Propriété
Intellectuelle
Bureau international



(43) Date de la publication internationale
24 mai 2007 (24.05.2007)

PCT

(10) Numéro de publication internationale
WO 2007/057555 A1

- (51) Classification internationale des brevets :
A61F 2/44 (2006.01)
- (21) Numéro de la demande internationale :
PCT/FR2006/002515
- (22) Date de dépôt international :
14 novembre 2006 (14.11.2006)
- (25) Langue de dépôt : français
- (26) Langue de publication : français
- (30) Données relatives à la priorité :
05 11596 16 novembre 2005 (16.11.2005) FR
- (71) Déposants et
(72) Inventeurs : POINTILLART, Vincent [FR/FR]; 146 Rue
Naujac, F-33000 Bordeaux (FR). ASSAKER, Richard
[BE/BE]; 62 Rue Du Vert Lion, B-7540 Kain (BE).
- (74) Mandataires : ROBERT, Jean-Pierre etc.; C/o Cabinet
Boettcher, 22 Rue Du Général Foy, F-75008 Paris (FR).
- (81) États désignés (sauf indication contraire, pour tout titre de
protection nationale disponible) : AE, AG, AL, AM, AT,
AU, AZ, BA, BB, BG, BR, BW, BY, BZ, CA, CH, CN, CO,
CR, CU, CZ, DE, DK, DM, DZ, EC, EE, EG, ES, FI, GB,
GD, GE, GH, GM, GT, HN, HR, HU, ID, IL, IN, IS, JP,
KE, KG, KM, KN, KP, KR, KZ, LA, LC, LK, LR, LS, LT,
LU, LV, LY, MA, MD, MG, MK, MN, MW, MX, MY, MZ,
NA, NG, NI, NO, NZ, OM, PG, PH, PL, PT, RO, RS, RU,
SC, SD, SE, SG, SK, SL, SM, SV, SY, TJ, TM, TN, TR,
TT, TZ, UA, UG, US, UZ, VC, VN, ZA, ZM, ZW.
- (84) États désignés (sauf indication contraire, pour tout titre
de protection régionale disponible) : ARIPO (BW, GH,
GM, KE, LS, MW, MZ, NA, SD, SL, SZ, TZ, UG, ZM,
ZW), eurasién (AM, AZ, BY, KG, KZ, MD, RU, TJ, TM),
européen (AT, BE, BG, CH, CY, CZ, DE, DK, EE, ES, FI,

[Suite sur la page suivante]

(54) Title: INTERVERTEBRAL DISC PROSTHESIS

(54) Titre : PROTHESE DE DISQUE INTERVERTEBRAL

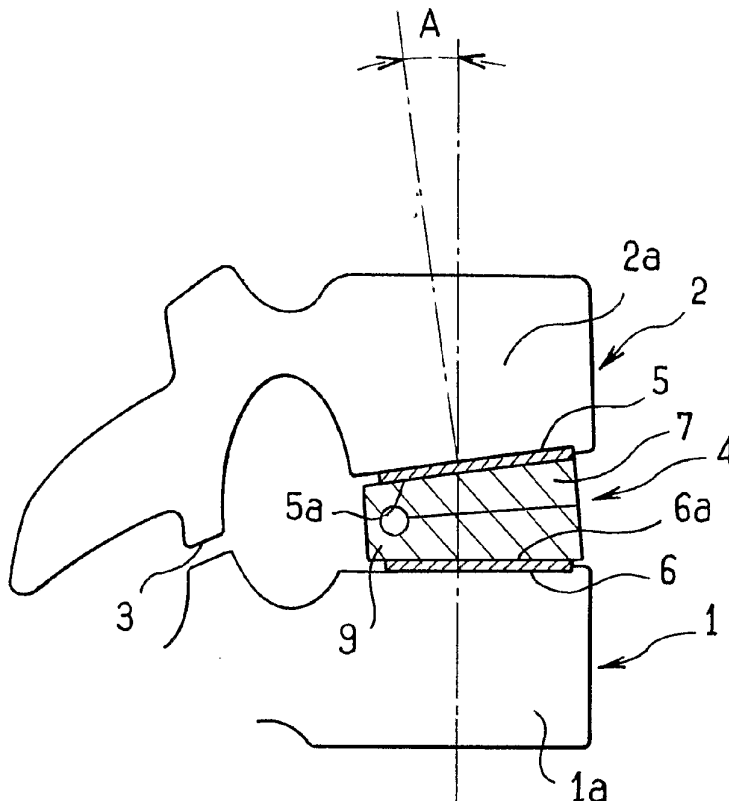

(57) Abstract: The invention relates to an intervertebral disc prosthesis (4) characterized in that it comprises: a rigid upper plate (5), a rigid lower plate (6), an intermediate cushion (7), which can be elastically compressed and is placed between the two inner surfaces of the plates (5, 6). The invention is also characterized in that the assembly is divided in the width direction into two units resting one atop the other via complementary contact surfaces.

(57) Abrégé : Prothèse (4) de disque intervertébral caractérisée en ce qu'elle comporte : - un plateau supérieur rigide (5), - un plateau inférieur rigide (6), - un coussin intermédiaire (7) élastiquement compressible, logé entre les deux surfaces internes des plateaux (5,6), remarquable en ce que l'ensemble est divisé dans le sens de l'épaisseur en deux unités reposant l'une sur l'autre par des surfaces de contact complémentaires.

WO 2007/057555 A1



FR, GB, GR, HU, IE, IS, IT, LT, LU, LV, MC, NL, PL, PT, RO, SE, SI, SK, TR), OAPI (BF, BJ, CF, CG, CI, CM, GA, GN, GQ, GW, ML, MR, NE, SN, TD, TG).

En ce qui concerne les codes à deux lettres et autres abréviations, se référer aux "Notes explicatives relatives aux codes et abréviations" figurant au début de chaque numéro ordinaire de la Gazette du PCT.

Publiée :

- avec rapport de recherche internationale
- avant l'expiration du délai prévu pour la modification des revendications, sera republiée si des modifications sont reçues

AN INTERVERTEBRAL DISK PROSTHESIS

The invention relates to an intervertebral disk prosthesis for replacing in full or in part the natural disks that provide the connection between two vertebrae of the vertebral column, regardless of the portion of the spine that is concerned.

BACKGROUND OF THE INVENTION

Each intervertebral disk of the vertebral column is constituted by a central element referred to as the nucleus pulposus that is enclosed in a winding of fibers referred to as the annulus. The disk provides a connection between two vertebral bodies and it controls the flexing, bending, and turning movements of the vertebral column. Such a disk can become damaged under the effect of time, effort, or certain degenerative diseases, and it then becomes flattened and/or ceases to function properly. This can lead to various types of pathology, leading to multiple more or less intense pains and to handicaps of greater or lesser extent.

Treatment for that type of disorder consists in removing the diseased disk and replacing it either with an element that is movable or deformable, or with an element that readily interconnects the two vertebrae concerned.

Several type of prosthesis have been proposed for replacing an intervertebral disk, however they are satisfactory in part only. They do indeed preserve mobility between vertebrae and restore the distance between the vertebrae to a value close to that provided by a healthy disk. However, in providing such mobility, they impose particular dynamics that are not compatible or that are only partially compatible with the natural relative mobility between two vertebrae. In most circumstances, the prosthesis imposes dynamics that are specific thereto, with its center of rotation and its various plane-on-plane guidances, and that inevitably

interfere with the natural joint elements that remain between two vertebrae, in particular the posterior articular facets. In this respect it is important to position the prosthesis with care since any inaccuracy in such placement increases the severity of the conflict between the dynamics of the prosthesis and natural dynamics. This non-physiological mobility can lead to undesirable clinical consequences. It is even possible that a component might migrate or that the prosthesis might become dislocated.

Furthermore, most known prostheses are unsuitable for restoring normal cervical or lumbar lordosis. Restoring the distance between vertebrae does not take account of the inclinations needed from one vertebra to the next in the stack of vertebrae in order to attain such natural lordosis, the existence of which is useful for normal biomechanics of the spine as a whole, and in particular of the adjacent levels.

Furthermore, known prostheses are not adapted to absorb shocks. A consequence of this unsuitability, associated with the conflict between the natural dynamics and the dynamics of the joint, can lead to premature wear both in natural elements and in elements of the prosthesis, thereby running the risk of degrading the patient's clinical state.

Any discussion of documents, acts, materials, devices, articles or the like which has been included in the present specification is solely for the purpose of providing a context for the present invention. It is not to be taken as an admission that any or all of these matters form part of the prior art base or were common general knowledge in the field relevant to the present invention as it existed before the priority date of each claim of this application.

Throughout this specification the word "comprise", or variations such as "comprises" or "comprising", will be understood to imply the inclusion of a stated element, integer or step, or group of elements, integers or steps, but not the exclusion of any other element, integer or step, or group of elements, integers or steps.

SUMMARY OF THE INVENTION

According to one aspect, the present invention provides an intervertebral disk prosthesis comprising:

a rigid top plate;

a rigid bottom plate; and

an elastically-compressible intermediate cushion received between the two inside surfaces of the plates;

the cushion having the feature of being subdivided in the thickness direction into two portions having a first section where the two portions are fixed together, and a second section where the two portions rest one on the other via complementary contact surfaces.

This structure is in the form of a part that does not impose any stressed connection between the two vertebrae it connects together (naturally this applies to amplitudes corresponding to natural relative movements). As a result, the natural guides for guiding such relative movements remain preponderant (in particular the posterior articular facets), and their integrity is preserved. In addition, at these contact surfaces, it is possible, by making an appropriate selection for their shape and their state, to govern the nature and the concentration of the stresses and the deformations that occur at said surfaces.

In a first embodiment of the invention, the complementary contact surfaces are formed in the thickness of the intermediate cushion, and preferably in the form of indentations and projections (teeth), the projections of one of them being complementary to the indentations of the other, so that they come into contact with each other over via least the surfaces of their flanks.

In a preferred embodiment of the invention, the elastically compressible intermediate cushion housed between the two inside surfaces of the plates possesses, in the free state, the general shape of a wedge between said two plates. This wedge shape of the structure enables the lordosis of the spine to be restored, which lordosis will generally have been degraded by the degeneration of the disk.

By way of example, the cushions may be based on high density polyethylenes, on high density polyurethanes, on silicones, or on composites of those various materials.

The prosthesis preferably includes a contention membrane for the cushion, which membrane is secured to the plates. The contention membrane serves to avoid biological invasion and colonization of the prosthesis. It also serves, in spite of all of the materials used being biocompatible, to isolate the cushion completely from the adjacent biological medium, and it forms a barrier to migration into the organism of any particles that might come from the cushion.

The membrane may be an annulus that is to be fastened to the plates (leaving direct contact between the cushion and each plate), or it may be a hermetically-sealed bag, enclosing the cushion, and for example bonded to the plates by adhesive, or indeed it may be a membrane that is sandwiched between each plate and a backing plate that is riveted thereto, the other face of the backing plate being in contact with the cushion.

Other structural arrangements appear on reading the description below. Particular mention can be made of the existence of a tie between the two plates of the prosthesis that enables the prosthesis to be kept in a compressed state so as to make it easier to put into place. One of the advantages of the prosthesis lies in that it is easy to put into place, and that this does not require great accuracy since there is no need to "match" its degrees of freedom with the natural degrees of freedom that exist between two vertebrae.

BRIEF DESCRIPTION OF THE DRAWINGS

Other characteristics and advantages of the invention appear from the description given below of a few embodiments thereof.

DETAILED DESCRIPTION OF THE INVENTION

Reference is made to the accompanying drawings, in which:

· Figure 1 shows a prosthesis of the invention placed between two cervical vertebrae;

· Figure 2 is an exploded view of an embodiment of a prosthesis in accordance with the invention;

5 · Figure 3 is a view of the Figure 2 prosthesis when closed and held compressed by a severable tie;

· Figure 4 shows an embodiment of the compressible cushion;

10 · Figure 5 shows a variant embodiment of the compressible cushion of the preceding figure;

· Figure 6 shows the cushion of the preceding figure folded in half;

· Figure 7 shows a variant embodiment of a compressible cushion; and

15 · Figure 8 is an exploded view of a variant embodiment of the prosthesis of the invention.

DETAILED DESCRIPTION OF THE INVENTION

Figure 1 shows two successive cervical vertebrae 1 and 2, each having a vertebral body 1a and 2a, and a posterior articular surface 3. Between the vertebral bodies, there is shown in diagrammatic manner a prosthesis 4 comprising two end plates 5 and 6 together with an intermediate body 7 in the form of a compressible cushion that is wedge-shaped with the tip or vertex (thin end) in the posterior position, the right-hand portion of the figure representing the anterior zone of the spine.

The end plates 5 and 6 of the prosthesis are in contact with the vertebral bodies 1a and 2a via surfaces of said bodies that have received prior preparation after removal of the damaged natural disk. The outside surfaces of these plates may include anchor means, e.g. portions in relief, in order to improve bone fixing; they may also make use of screws or any other equivalent element. The spine is shown presenting lordosis through an angle A that imposes on the prosthesis the relative orientation of these two vertebrae.

In Figure 2, it can be seen that each of the plates 5 and 6 possesses an inside surface 5a, 6a, drawn as plane, but that could possibly have a substantially spherical or cylindrical concave shape. The compressible cushion 7 is fastened to the plate. This cushion is enclosed in a contention membrane 8 that biologically isolates the cushion from the remainder of the patient's body. The membrane is fastened to the remainder of the prosthesis by any appropriate means. By way of example, mention can be made of a "cylindrical" membrane fastened to the edge of each plate (in particular by crimping); the membrane may also be such that its edge is sandwiched between the inside face of each plate and a backing plate fitted thereto, e.g. by riveting. The membrane may also be in the form of a completely closed bag with the plates being stuck thereto.

Figure 3 shows the prosthesis in its state ready for being inserted between two vertebrae, this state corresponding to the compressible cushion 7 being held in a compressed state by a tie 10 disposed on the anterior face of the prosthesis 4 and that is suitable for being ruptured after the prosthesis has been put into place between the vertebral bodies 1a and 2a. The tie may also be placed in such a manner as to surround the entire prosthesis so that it can be ruptured and removed after being cut, when necessary, by the surgeon acting via a posterior approach.

In this figure, it can be seen that the plates 5 and 6 are of dimensions such that, in the posterior portion of the prosthesis, they are set back from the cushion which projects beyond the plates via a portion 9 beside the tip of the wedge.

Figure 4, as a detail corresponding to the preceding figures, shows an elastically compressible cushion 7 that is folded in half, having two portions 7a and 7b folded one onto the other about a portion 7c that constitutes a thin zone forming a folding hinge that becomes the

posterior end of the wedge. The prosthesis is thus subdivided into two units that co-operate with each other via complementary contact surfaces, here represented diagrammatically as being plane surfaces.

5 In Figure 5, the cushion 11 shown likewise possesses two membranes 11a and 11b that can be folded one onto the other about a thin zone 11c acting as a folding hinge, such that, as shown in Figure 6, indentations 12 can interpenetrate when the two portions are folded one
10 against the other. It can be understood that the contact surface via which the two units of the prosthesis co-operate is complex in this embodiment: it comprises the flanks of interpenetrating teeth. On fabrication, it is possible to select the angle of inclination of the
15 indentations 12, the number of indentations, their profile, ... as a function of the elastic characteristics and of the behavior desired for the cushion.

 In a variant (not shown) the indentations are curved, e.g. in circular arcs centered beside the hinge.

20 In another variant (not shown) the two portions 11a and 11b can be separate (the hinge being omitted) and merely superposed with their indentations interleaved.

 In Figure 7, the cushion 13 as shown constitutes a kind of resilient capsule for a gel core 14 that can
25 deform depending on the extent to which the cushion is compressed during intervertebral movements. In this embodiment, the prosthesis likewise satisfies the general definition of the invention, i.e. the lens of gel subdivides the prosthesis into two units possessing
30 surfaces that co-operate with each other via a gel. In other words, the functional complementarity of the surfaces is provided by the gel lens.

 Finally, Figure 8 shows a variant embodiment of the prosthesis reproducing most of the elements described
35 above and given the same references. Inside the membrane (not shown), this variant embodiment has two slide tabs 15 and 16 situated in the vicinity of one of the plates,

between the cushion and that plate. The subdivision of the prosthesis into two units is performed in this embodiment outside the cushion, the complementary surfaces being slide planes with surface states prepared so as to correspond with desired behavior. The cushion is shown as being a single piece. It could also be made as two portions folded one on the other, with the ability to slide being in addition to the performance of the prosthesis that results from it being separated into two units as described above.

Advantageously, at least one of the plates 5 and 6, and preferably both of them, is dimensioned in such a manner that the prosthesis has a cushion that projects beyond the plates, behind them, so as to leave a space adjacent to the posterior portion of the spine in which there is no metal element, with this being done for two purposes:

- limiting the artifact (degraded imagery) concerning this posterior portion of the spine by keeping the metal portion constituted by the plate away therefrom; and

- facilitating decompression (resection of the posterior wedges of the vertebral plates).

Finally, it should be mentioned that the above-described prosthesis corresponds to a single-piece prosthesis that is put into place using an anterior approach. In an embodiment adapted to be put into place via a posterior approach, it would comprise two half-protheses that are put into place via lateral approaches so as to be placed on either side of the remaining portion (nucleus pulposus) of the natural disk. The shape of each half-prosthesis should then be adapted to the morphology that is encountered, e.g. by being kidney-bean shaped, when seen from above. Each half-prosthesis should be subdivided into two units using the various above-described variants.

WHAT IS CLAIMED IS:

1. An intervertebral disk prosthesis, comprising:
a rigid top plate;
5 a rigid bottom plate; and
an elastically-compressible intermediate cushion
received between the two inside surfaces of the plates;
wherein the cushion is subdivided in the thickness
direction into two portions, the two portions having a
10 first section where the two portions are fixed together,
and a second section where the two portions releasably
rest one on the other via complementary contact surfaces.

2. A prosthesis according to claim 1, wherein the
15 cushion is a component that is folded in half about the
first section.

3. A prosthesis according to claim 1 or 2, wherein the
two portions of the cushion are fixed at the first
20 section by a thin zone forming a hinge for folding one
portion down onto the other.

4. A prosthesis according to claim 1, 2 or 3, wherein
the two portions are integrated at the first section.
25

5. A prosthesis according to any one of the preceding
claims, wherein the first section is provided adjacent to
a lateral edge of the cushion.

- 30 6. A prosthesis according to any one of the preceding
claims, wherein the cushion is formed as a one-piece
element.

7. A prosthesis according to any one of the preceding claims, wherein, in the free state, the prosthesis is generally wedge-shaped between the two plates.

5 8. A prosthesis according to any one of the preceding claims, including a contention membrane for the cushion, which membrane is secured to the plates.

10 9. A prosthesis according to any one of the preceding claims, including a tie for holding the cushion in the compressed state, and suitable for being severed after the prosthesis has been put into place.

15 10. A prosthesis according to any one of the preceding claims, wherein the complementary contact surfaces of the two portions are provided with interleaved indentations.

20 11. A prosthesis according to any one of the preceding claims, wherein the two complementary surfaces constitute the walls of a gel lens included in the cushion.

25 12. A prosthesis according to any one of the preceding claims, having two slide tabs between the cushion and one of the plates.

30 13. A prosthesis according to any one of the preceding claims, wherein the plates are limited in their rear portions, the prosthesis thus having a posterior portion of the cushion projecting from said plates.

14. An intervertebral disk prosthesis substantially as any one embodiment described herein with reference to the accompanying Figures.

1/2

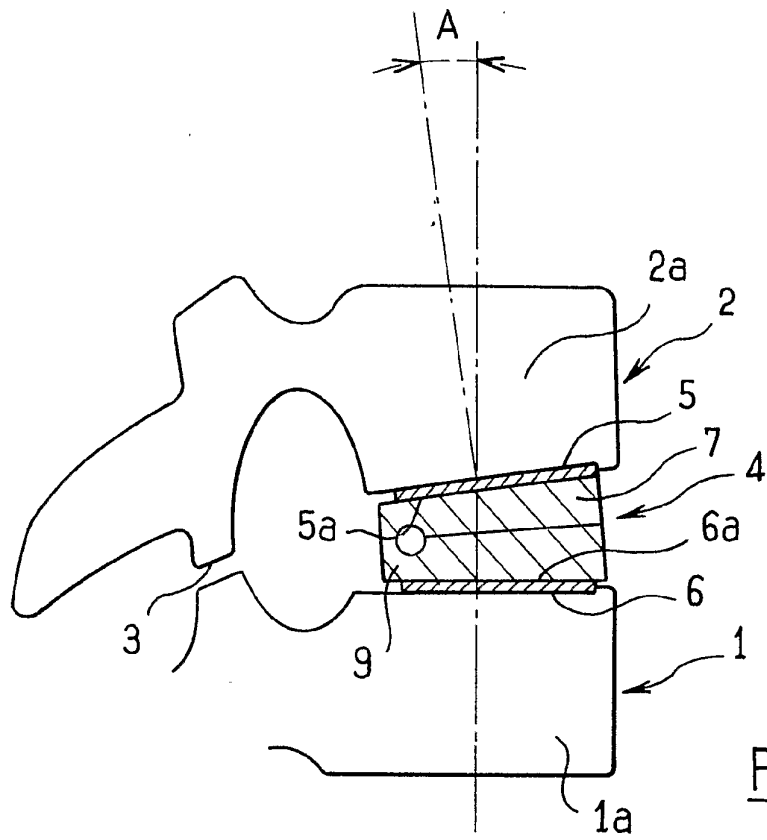

FIG. 1

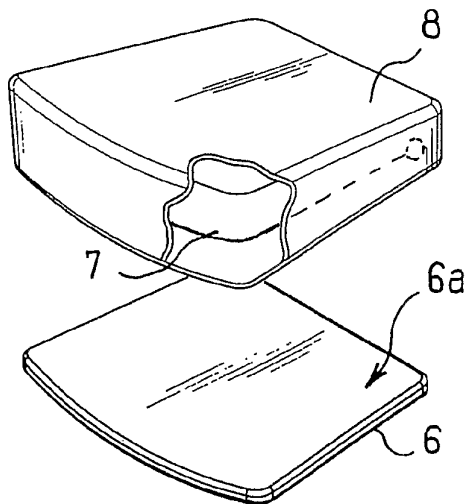
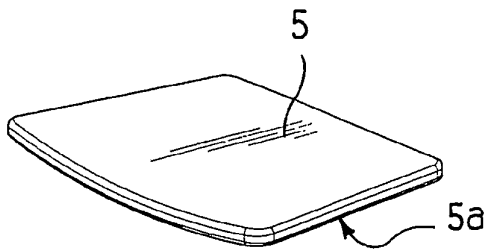

FIG. 2

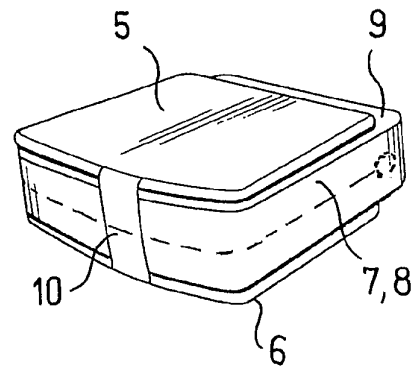

FIG. 3

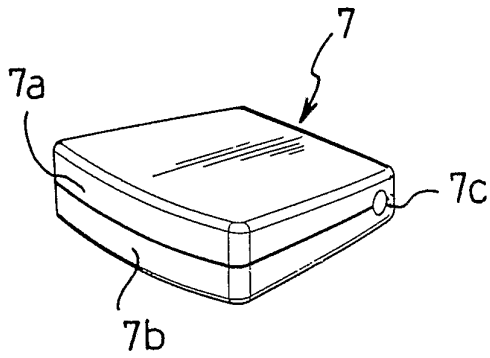

FIG. 4

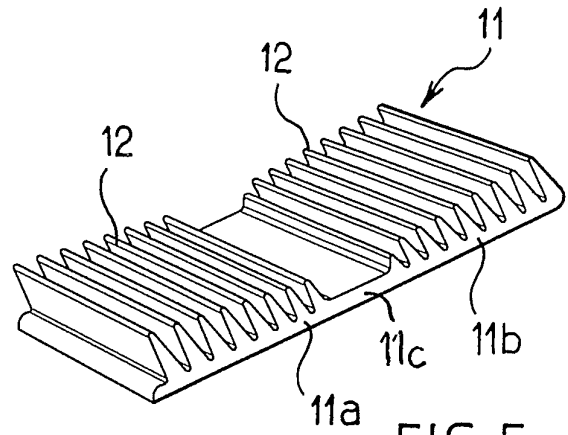

FIG. 5

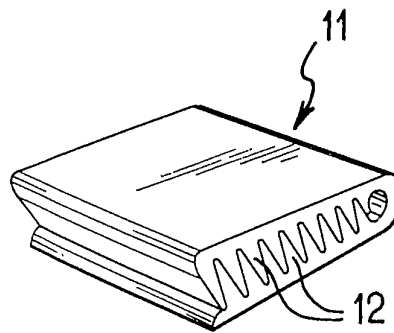

FIG. 6

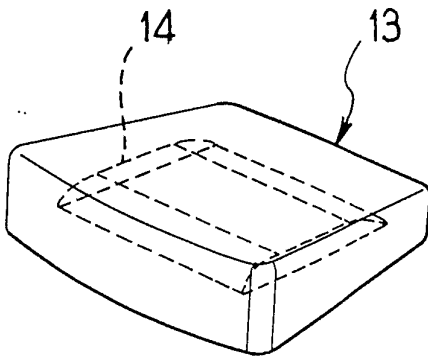

FIG. 7

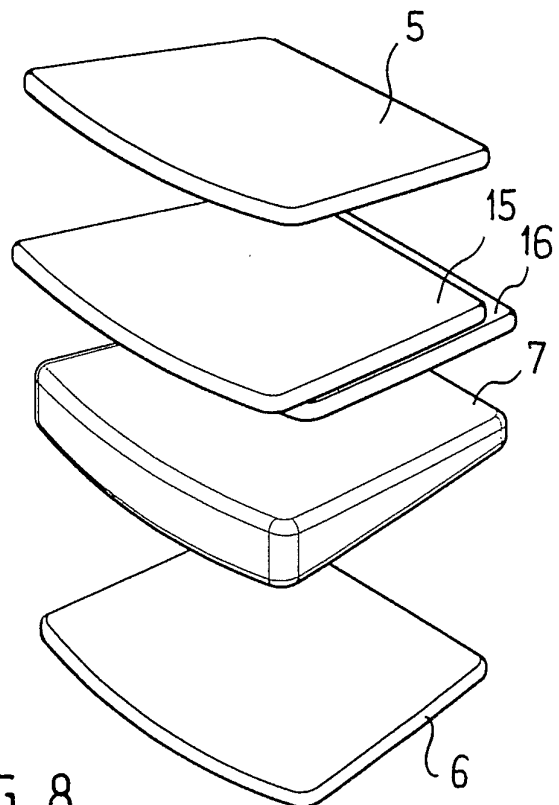

FIG. 8