

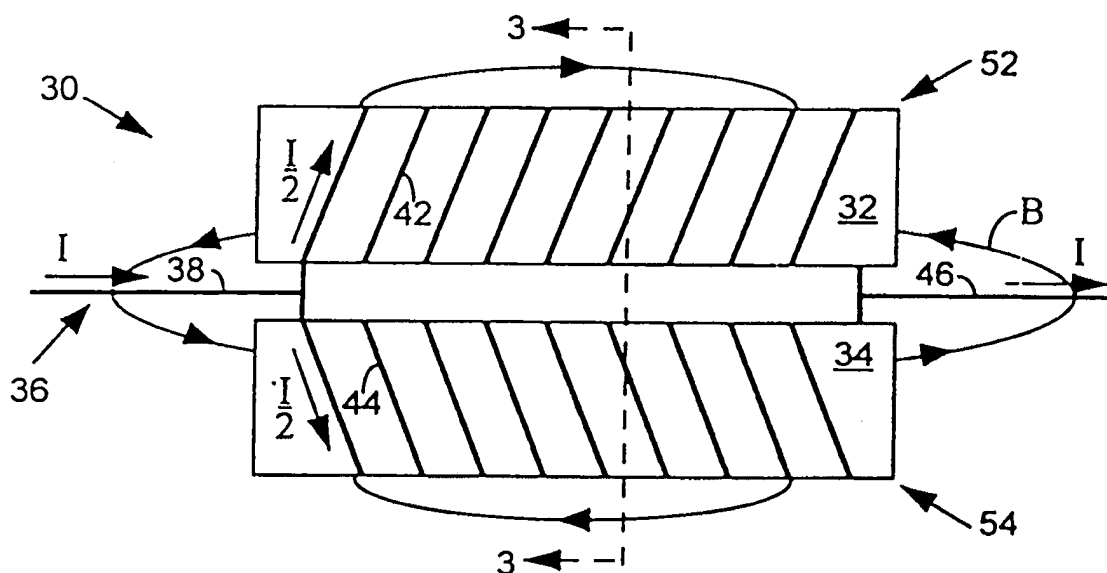

## INTERNATIONAL APPLICATION PUBLISHED UNDER THE PATENT COOPERATION TREATY (PCT)

<p>(51) International Patent Classification<sup>6</sup> : <b>H01F 17/04</b></p>	<p><b>A1</b></p>	<p>(11) International Publication Number: <b>WO 98/43255</b> (43) International Publication Date: 1 October 1998 (01.10.98)</p>
<p>(21) International Application Number: PCT/US98/05365 (22) International Filing Date: 18 March 1998 (18.03.98) (30) Priority Data: 08/821,841 21 March 1997 (21.03.97) US (71) Applicant (for all designated States except US): RAYCHEM CORPORATION [US/US]; 300 Constitution Drive, Mail Stop 120/6600, Menlo Park, CA 94025-1164 (US). (72) Inventors; and (75) Inventors/Applicants (for US only): MORRIS, Arthur, Sherman, III [US/US]; 2040 Oakton Drive, Raleigh, NC 27606 (US). O'STEEN, Steven, Bryan [US/US]; 624 Wagstaff Road, Fuquay-Varina, NC 27526 (US). (74) Agents: REGAN, Christopher, F. et al.; Allen, Dyer, Doppelt, Milbrath &amp; Gilchrist, P.A., Suite 1401, 255 S. Orange Avenue, P.O. Box 3791, Orlando, FL 32802-3791 (US).</p>		<p>(81) Designated States: AL, AM, AT, AU, AZ, BA, BB, BG, BR, BY, CA, CH, CN, CU, CZ, DE, DK, EE, ES, FI, GB, GE, HU, IL, IS, JP, KE, KG, KP, KR, KZ, LC, LK, LR, LS, LT, LU, LV, MD, MG, MK, MN, MW, MX, NO, NZ, PL, PT, RO, RU, SD, SE, SG, SI, SK, TJ, TM, TR, TT, UA, UG, US, UZ, VN, European patent (AT, BE, CH, DE, DK, ES, FI, FR, GB, GR, IE, IT, LU, MC, NL, PT, SE).  <b>Published</b> <i>With international search report.</i></p>

## (54) Title: RF CHOKES COMPRISING PARALLEL COUPLED INDUCTORS



## (57) Abstract

An RF choke (30) that can have a higher inductance and a higher current carrying capacity than RF chokes heretofore available. Two coils (42, 44) are counter-wound around two cylindrical cores (32, 34) so that the magnetic fields add in the respective cores. This can be accomplished in at least two ways: 1) two independent but counter-wound electrically parallel coupled cores located closely together, and 2) two cores wound in a figure-eight pattern. The two approaches yield one effective choke on two counter-wound cores.

**FOR THE PURPOSES OF INFORMATION ONLY**

Codes used to identify States party to the PCT on the front pages of pamphlets publishing international applications under the PCT.

<b>AL</b>	Albania	<b>ES</b>	Spain	<b>LS</b>	Lesotho	<b>SI</b>	Slovenia
<b>AM</b>	Armenia	<b>FI</b>	Finland	<b>LT</b>	Lithuania	<b>SK</b>	Slovakia
<b>AT</b>	Austria	<b>FR</b>	France	<b>LU</b>	Luxembourg	<b>SN</b>	Senegal
<b>AU</b>	Australia	<b>GA</b>	Gabon	<b>LV</b>	Latvia	<b>SZ</b>	Swaziland
<b>AZ</b>	Azerbaijan	<b>GB</b>	United Kingdom	<b>MC</b>	Monaco	<b>TD</b>	Chad
<b>BA</b>	Bosnia and Herzegovina	<b>GE</b>	Georgia	<b>MD</b>	Republic of Moldova	<b>TG</b>	Togo
<b>BB</b>	Barbados	<b>GH</b>	Ghana	<b>MG</b>	Madagascar	<b>TJ</b>	Tajikistan
<b>BE</b>	Belgium	<b>GN</b>	Guinea	<b>MK</b>	The former Yugoslav Republic of Macedonia	<b>TM</b>	Turkmenistan
<b>BF</b>	Burkina Faso	<b>GR</b>	Greece	<b>ML</b>	Mali	<b>TR</b>	Turkey
<b>BG</b>	Bulgaria	<b>HU</b>	Hungary	<b>MN</b>	Mongolia	<b>TT</b>	Trinidad and Tobago
<b>BJ</b>	Benin	<b>IE</b>	Ireland	<b>MR</b>	Mauritania	<b>UA</b>	Ukraine
<b>BR</b>	Brazil	<b>IL</b>	Israel	<b>MW</b>	Malawi	<b>UG</b>	Uganda
<b>BY</b>	Belarus	<b>IS</b>	Iceland	<b>MX</b>	Mexico	<b>US</b>	United States of America
<b>CA</b>	Canada	<b>IT</b>	Italy	<b>NE</b>	Niger	<b>UZ</b>	Uzbekistan
<b>CF</b>	Central African Republic	<b>JP</b>	Japan	<b>NL</b>	Netherlands	<b>VN</b>	Viet Nam
<b>CG</b>	Congo	<b>KE</b>	Kenya	<b>NO</b>	Norway	<b>YU</b>	Yugoslavia
<b>CH</b>	Switzerland	<b>KG</b>	Kyrgyzstan	<b>NZ</b>	New Zealand	<b>ZW</b>	Zimbabwe
<b>CI</b>	Côte d'Ivoire	<b>KP</b>	Democratic People's Republic of Korea	<b>PL</b>	Poland		
<b>CM</b>	Cameroon	<b>KR</b>	Republic of Korea	<b>PT</b>	Portugal		
<b>CN</b>	China	<b>KZ</b>	Kazakstan	<b>RO</b>	Romania		
<b>CU</b>	Cuba	<b>LC</b>	Saint Lucia	<b>RU</b>	Russian Federation		
<b>CZ</b>	Czech Republic	<b>LI</b>	Liechtenstein	<b>SD</b>	Sudan		
<b>DE</b>	Germany	<b>LK</b>	Sri Lanka	<b>SE</b>	Sweden		
<b>DK</b>	Denmark	<b>LR</b>	Liberia	<b>SG</b>	Singapore		
<b>EE</b>	Estonia						

**RF CHOKES COMPRISING  
PARALLEL COUPLED INDUCTORS**

BACKGROUND OF THE INVENTION

1. Field of the Invention

This invention relates to radio frequency (RF) chokes, and more particularly to a device for  
5 separating a single phase AC power signal from a broadband signal carried on the same conductor, the device having a higher inductance and a higher current carrying capacity than RF chokes heretofore available.

2. Introduction to the Invention

10 It is well known in systems distributing RF signals, such as cable television signals, data transmission signals, and the like, to combine the broadband RF signals, e.g. 5 MHz to 1 GHz, with an AC power signal, e.g. 60 Hz in the United States, on a  
15 single coaxial cable. The AC power signal is transmitted on the same cable that transmits the RF signal in order to supply power to amplifiers, repeaters, and other equipment associated with the cable system. It is common for such cable systems to  
20 carry AC power at a current magnitude generally in the range of about 10 to 12 amps, and even as high as about 14 to 15 amps.

At specified locations in a cable distribution system, it is then necessary to separate the combined  
25 AC power and RF signals, for example, to provide the AC

-2-

power to associated equipment, and to do so without degrading the RF signal. It is well known to employ inductors in circuits designed to separate the AC power from the RF signals. In such applications, the  
5 inductors are commonly referred to as RF chokes. Since the impedance, i.e. reactance, of an inductor increases with frequency, RF chokes are designed to exhibit a relatively high impedance to signals in the RF frequency range, commonly above 5MHz, a relatively low  
10 impedance to the AC power signal, and to minimize resonance effects at the higher frequencies.

It is known that, in general, the quality of an RF choke may be characterized in terms of three properties: inductance value, current carrying  
15 capacity, and resonant frequency. It is known that these three properties must be balanced in a practical design. Standard cylindrical chokes commonly include an insulated wire coiled into a helix. The inductance level needed to present a sufficiently high impedance  
20 at the RF frequencies is achieved by introducing a magnetic core into the center of the coil. The magnetic core is commonly comprised of ferrite material. Other linear magnetic materials, e.g. powdered iron and laminated steel may also be used.  
25 Ferrite cores are commonly preferred for high frequency, e.g. greater than about 1 MHz, applications. However, it is known that the properties of the magnetic core will change above a saturation level of magnetic flux density. This limits the current  
30 carrying capacity of the RF choke to a level below the saturation level of the core.

Parasitic capacitance can result from wrapping a conductor around a core. The effect of parasitic capacitance electrically coupled in series with the  
35 inductor is to form a series LC circuit having a resonant frequency, with a concomitant sharp loss in impedance at the resonant frequency. The Q of the

resonant LC circuits may be quite high.

The inductance of an RF choke can be raised by increasing the number of turns in the coil. However, this can lower the resonant frequency into the band of operation. Reducing the number of turns in the coil to reduce the resonance may reduce the inductance to a value that makes the RF choke no longer useful in the frequency range of interest.

Several attempts have been made at improving the performance of RF chokes. In order to reduce the Q of the series LC circuit, a resistor may be electrically coupled between specified turns of the inductor coil. The spacing between the individual conductor coils may be increased to decrease parasitic capacitance and damp the resonance. However, the inductance of an RF choke is dependent on the coil spacing to the second order. Therefore, an effect of spreading out the coil spacing can be to reduce the inductance of the coil. Air coils of one or more turns may be included to avoid saturating the core. However, this approach requires a compromise at the lower frequencies since much less inductance can be obtained. The diameter of the core may be increased to lower the flux density for a given current level. However, this increases the wire length and causes high frequency resonance problems.

There is therefore a need for an RF choke which can have a higher inductance and a higher current carrying capacity without a significant resonance in the RF band of interest.

#### 30 SUMMARY OF THE INVENTION

We have now invented an RF choke that can have a higher inductance and a higher current carrying capacity than RF chokes heretofore available. In a first aspect the invention provides an RF choke comprising first and second cores.

In one embodiment, an RF choke of the invention comprises a first wire coil wound upon the first core;

and a second wire coil wound upon the second core;  
wherein: the two cores are aligned substantially  
parallel; the first wire coil and the second wire coil  
are wound in opposite directions around the first and  
5 second cores; and the first wire coil and the second  
wire coil are electrically coupled in parallel.

In a second embodiment, an RF choke of the  
invention comprises a wire coil wound upon the cores,  
wherein: the two cores are aligned substantially  
10 parallel; the wire coil forms at least two successive  
windings in series with each other, with a first  
winding wound in one direction around the first core  
and a second winding wound in the opposite direction  
around the second core.

15 While cylindrical cores are preferred for use in  
RF chokes of the invention, elongate cores having other  
cross-sections, e.g. polygon, having parallel  
longitudinal axes, may also be used. In addition, it  
is preferred that the core comprise a low-loss material  
20 with a relative magnetic permeability greater than 1.  
Air or dielectric cores may also be used, in which case  
the current carrying capacity would be limited by the  
thermal power limit of the wires rather than core  
saturation.

25 If two cylindrical chokes are placed side by side,  
each interacts with the fringing magnetic field of the  
other. Depending on the direction of the windings, the  
magnetic fields can add or subtract. If the coils are  
counter wound, so that the magnetic fields add in each  
30 core, higher inductance is obtained and much higher  
currents are feasible. This can be accomplished in at  
least two ways: 1) two independent but counter-wound  
parallel connected cores located closely together, and  
2) two cores wound in a figure-eight pattern. The two  
35 approaches yield one effective choke on two counter-  
wound cores.

The inductance of a choke comprising two

-5-

cylindrical cores increases as the cores are moved closer together. Thus, in preferred embodiments, the wire-wound cores are placed in juxtaposition. In an embodiment comprising two independent, counter-wound  
5 cores, the cores are placed substantially two wire thicknesses apart. In an embodiment comprising two cores wound in a figure-eight pattern, the cores are placed substantially one wire thickness apart.

By way of example, one present commercial line of  
10 outdoor cable TV taps includes a choke that is made on a .164 inch diameter by .873 inch long ferrite core. The choke is wound with 12 turns of 20 gauge wire tightly wound together except for an approximately .050 inch gap in the center, i.e., 5 1/2 turns, then a 1  
15 turn spread, then 5 1/2 more turns. This choke has an inductance of about 2  $\mu$ H and is fairly linear up to about 7 amps RMS of 60 Hz current. The choke does have a small hum in a 14 dB 4-way outdoor tap. Above about 7 amps RMS, the peak current saturates the ferrite core  
20 and causes significant hum modulation of the RF signal through the tap.

An improved RF choke of the invention was made by winding two chokes, one wound identical to the choke used in the tap described above, and the second in the  
25 same manner except wound with the opposite pitch. The two chokes were then connected in parallel. The parallel combination provided about 2  $\mu$ H inductance, not 1  $\mu$ H that a simple parallel element calculation would predict. The RF performance, i.e. return loss  
30 and insertion loss, of the tap was unimpaired, and the tap was free of significant hum modulation to greater than 10 amps.

The scope of the invention is not limited to RF chokes in cable TV applications. RF chokes in  
35 accordance with the invention may be used to advantage in applications, e.g., from 800 MHz cellular telephones through the millimeter wave band. Improved chokes of

-6-

the invention may be used in bias tees for amplifiers and other active elements where current carrying capability is often a limiting factor.

Moreover, RF chokes of the invention may be  
5 employed to advantage both: in applications, including those referenced above, in which the low frequency AC signal is passed, and the high frequency RF signal is filtered in a manner so as to preserve the RF signal for subsequent use; and in applications, e.g. RFI  
10 filters, wherein the AC power is passed, and the higher frequency signal is filtered out and not preserved for subsequent use.

#### BRIEF DESCRIPTION OF THE DRAWINGS

The invention is illustrated in the accompanying  
15 drawings, in which:

FIG. 1 is a plan view of a prior art RF choke.

FIG. 2 is a plan view of an embodiment of an RF choke of the invention.

FIG. 3 is a cross sectional view of the embodiment  
20 of an RF choke in FIG. 2 taken along the plane 3-3.

FIG. 4 is a plan view of a second embodiment of an RF choke of the invention.

FIG. 5 is a cross sectional view of the embodiment  
of an RF choke in FIG. 4 taken along the plane 5-5.

25 Note that none of the drawings are to scale, including, in particular, the representations of the windings and the spacing of the windings of the wire coils.

#### DETAILED DESCRIPTION OF THE INVENTION

30 FIG. 1 is a plan view of a prior art RF choke which is indicated generally by the reference numeral 10. The choke 10 comprises a cylindrical core 12 and a conductor 14 wound on the core 12 to form a winding 18 having a predetermined number of turns. The conductor

-7-

has an input lead 16 and an output lead 22. Parasitic capacitance between the windings 18 is represented by a capacitor 24 shown electrically coupled between two of the windings. The magnetic field generated by a  
5 current  $I$  flowing through the conductor is indicated by the pattern generally representing the flux density  $B$ . Since the choke 10 comprises a single winding 18, the current  $I$  flowing through the winding 18 is the same as the current  $I$  flowing in the input lead 16 and out the  
10 output lead 22. The number and spacing of the windings 18 may vary among chokes used for different applications, and among chokes produced by different manufacturers. In addition, as described above, prior art RF chokes may include additional components, e.g.  
15 resistors electrically coupled between selected windings (not illustrated in any of the FIGS.), etc.

FIG. 2 is a plan view of an embodiment of an RF choke of the invention which is indicated generally by the reference numeral 30. The choke 30 comprises a  
20 first cylindrical core 32, a second cylindrical core 34, and a conductor 36. The first core 32 and second core 34 have the same length and the same diameter. The conductor 36 has an input lead 38, an output lead 46, a first winding 42 and a second winding 44. The  
25 first winding 42 and second winding 44 are electrically coupled in parallel, with the parallel combination electrically coupled in series between the input lead 38 and output lead 46. The first winding 42 and second winding 44 are wound in opposite directions about the  
30 first core 32 and second core 34, respectively. Since the choke 30 comprises two windings 42, 44 the current flowing through each of the respective windings 42,

-8-

44, represented as  $I/2$ , is half of the total current, represented as  $I$ , flowing in the input lead 38 and out the output lead 46. A first inductor 52 formed by the combination of the first core 32 and first winding 42 is thus electrically coupled in parallel with a second inductor 54 formed by the combination of the second core 34 and second winding 44. The magnetic field generated by a current  $I$  flowing through the choke 30 is indicated by the pattern generally representing the flux density  $B$ . With the first inductor 52 and second inductor 54 positioned in parallel, and side-by-side, each inductor interacts with the fringing magnetic field of the other inductor.

FIG. 3 is a cross sectional view of the embodiment of an RF choke in FIG. 2 taken along the plane 3-3. This view depicts the two inductors 52, 54 formed from the counter wound cores 32, 34, and the direction of current flow in the respective windings 42, 44 around the two cores 32, 34.

FIG. 4 is a plan view of a second embodiment of an RF choke of the invention which is indicated generally by the reference numeral 60. The choke 60 comprises a first cylindrical core 62, a second cylindrical core 64, and a conductor 66. The first core 62 and second core 64 have the same length and the same diameter. The conductor 66 has an input lead 68, an output lead 76, and a winding 72, 72'. The winding 72, 72' is wound alternatively around the first core 62 and second core 64, in a figure-eight pattern, and is thereby wound in opposite directions about the first core 62 and second core 64. Since the choke 60 comprises only

one winding 72, 72', the current flowing through the winding 72, 72' is the same as the total current, represented as I, flowing in the input lead 68 and out the output lead 76. The result is a single choke 60  
5 formed on the two counter-wound cores 62, 64. The magnetic field generated by a current I flowing through the choke 60 is indicated by the pattern generally representing the flux density B.

FIG. 5 is a cross sectional view of the second  
10 embodiment of an RF choke in FIG. 4 taken along the plane 5-5. This view depicts the two cores 62, 64 with the counter wound figure-eight winding pattern, and the direction of current flow in the windings 72, 72' around the two cores 62, 64.

15 Although not illustrated in any of the FIGS., those skilled in the art recognize that the turn-to-turn spacing of the windings on each of the cores in the embodiments of the invention depicted in the FIGS. may be selected to obtain a desired turn-to-turn  
20 capacitance, in order to adjust the resonant frequencies of the RF chokes. In particular, while the invention provides RF chokes with a higher current carrying capacity with a smaller core, the larger resonances which, in prior art RF chokes would require  
25 resistors electrically coupled between selected turns of the winding, typically fall outside the frequency band of interest. However, those skilled in the art will also recognize that a gap between the center turns of the windings on each core will serve to further  
30 reduce the effects of remaining smaller resonances.

The foregoing detailed description of the invention includes passages which are chiefly or exclusively concerned with particular parts or aspects of the invention. It is to be understood that this is

-10-

for clarity and convenience, that a particular feature may be relevant in more than just the passage in which it is disclosed, at that the disclosure herein includes all the appropriate combinations of information found  
5 in the different passages. Similarly, although the various figures and descriptions herein relate to specific embodiments of the invention, it is to be understood that where a specific feature is disclosed in the context of a particular figure, such feature can  
10 also be used, to the extent appropriate, in the context of another figure, in combination with another feature, or in the invention in general.

Further, while the present invention has been particularly described in terms of certain preferred  
15 embodiments, the invention is not limited to such preferred embodiments. Rather, the scope of the invention is defined by the appended claims.

-11-

## WHAT IS CLAIMED IS:

1. An RF choke comprising first and second cores.
  2. An RF choke according to claim 1 comprising:
    - a. a first wire coil wound upon the first core;
    - 5       and
    - b. a second wire coil wound upon the second core;
- wherein,
- i. the two cores are aligned substantially parallel;
  - 10       ii. the first wire coil and the second wire coil are wound in opposite directions around the first and second cores; and
  - iii. the first wire coil and the second wire coil
  - 15       are electrically coupled in parallel.
3. An RF choke according to claim 2 wherein:
    - a. the first wire coil and second wire coil comprise an insulated wire having a thickness; and
    - 20       b. the first core and second core are mounted in juxtaposition substantially two wire thicknesses apart.
  4. An RF choke according to claim 1 comprising a wire coil wound upon the cores wherein:
    - 25       a. the two cores are aligned substantially parallel;
    - b. the wire coil forms at least two successive windings in series with each other, with a first winding wound in one direction around
    - 30       the first core and a second winding wound in the opposite direction around the second core.
  5. An RF choke according to claim 4 wherein:
    - a. the wire coil comprises an insulated wire
    - 35       having a thickness; and
    - b. the first core and second core are mounted in

-12-

juxtaposition, substantially one wire thickness apart.

6. An RF choke according to claim 1 wherein the first core and second core comprise a low-loss material with a relative magnetic permeability greater than 1.

7. An RF choke according to claim 6 wherein the first core and second core comprise a material selected from the group comprising:

- a. ferrite;
- 10 b. powdered iron; and
- c. laminated steel.

8. An RF choke according to claim 1 wherein the first core and second core comprise a material selected from the group comprising:

- 15 a. air; and
- b. a dielectric material.

9. An RF choke according to claim 1 wherein the first core and second core have elongate cylindrical shapes, with the first core having a first length and a first diameter, and the second core having a second length and a second diameter.

10. An RF choke according to claim 9 wherein the first core and second core have the same length and the same diameter.

25

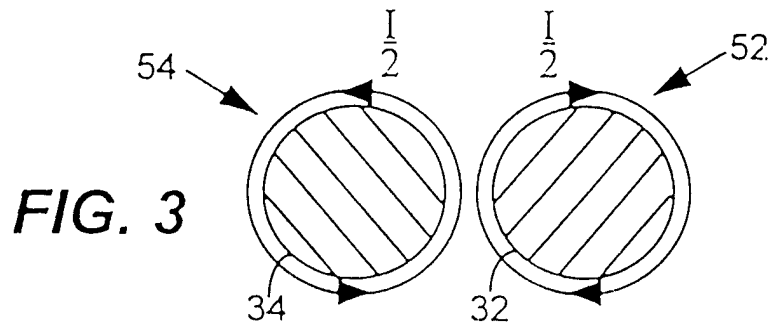
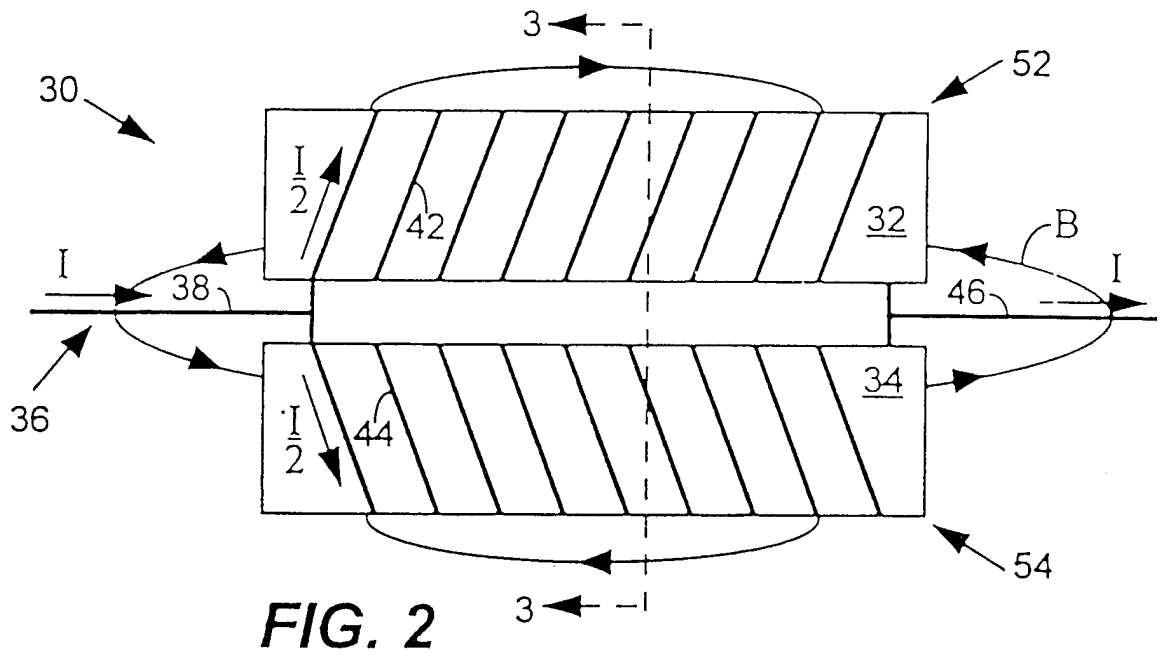
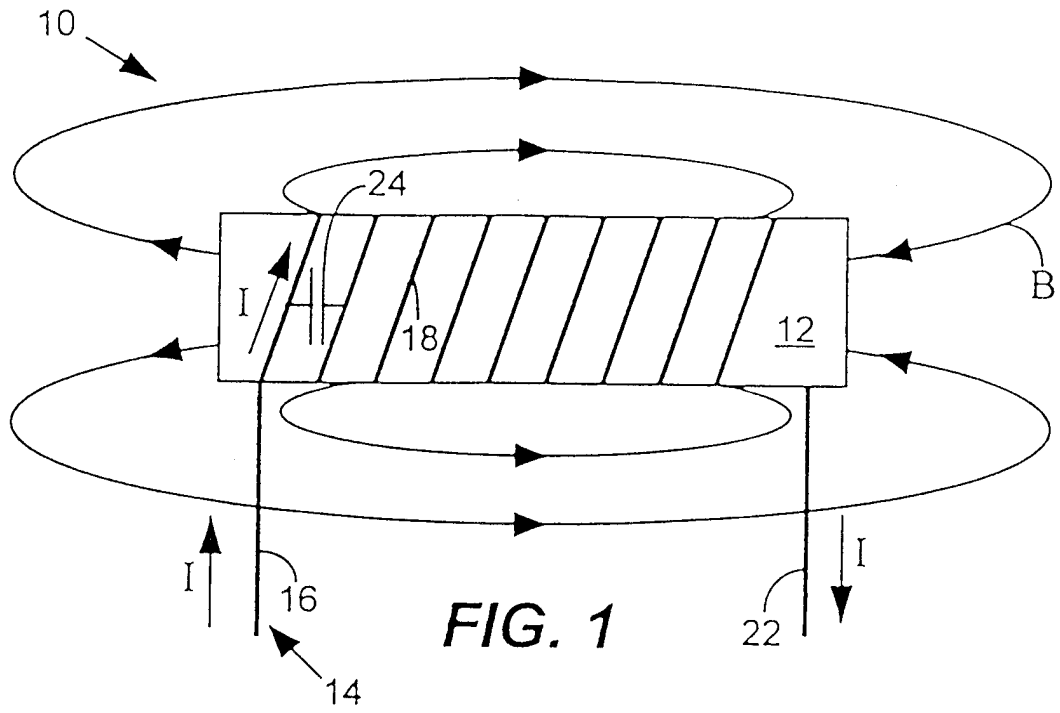

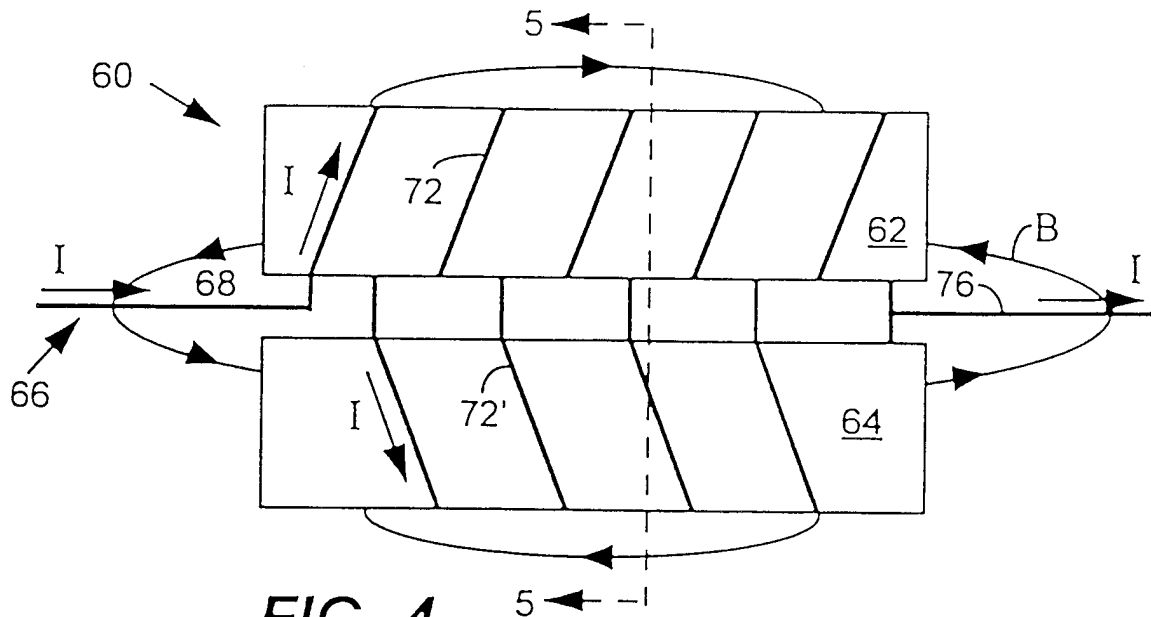

**FIG. 4**

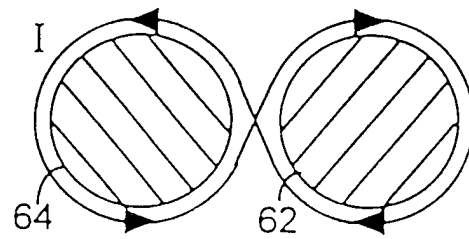

**FIG. 5**

# INTERNATIONAL SEARCH REPORT

International Application No

PCT/US 98/05365

**A. CLASSIFICATION OF SUBJECT MATTER**  
IPC 6 H01F17/04

According to International Patent Classification (IPC) or to both national classification and IPC

**B. FIELDS SEARCHED**

Minimum documentation searched (classification system followed by classification symbols)  
IPC 6 H01F

Documentation searched other than minimum documentation to the extent that such documents are included in the fields searched

Electronic data base consulted during the international search (name of data base and, where practical, search terms used)

**C. DOCUMENTS CONSIDERED TO BE RELEVANT**

Category	Citation of document, with indication, where appropriate, of the relevant passages	Relevant to claim No.
P, X	WO 97 19458 A (ERICSSON TELEFON AB L M ;LINDQVIST BENGT ARNE YNGVE (SE)) 29 May 1997 see page 3, line 8 - line 18; figures 2A, 2B	1, 6, 7, 9, 10
L	& SE 504 592 A (ERICSSON) 10 March 1997 ---	
A	DE 41 03 297 A (SCHULTE UEBBING ERNST DR) 13 August 1992 see column 1, line 45 - last line ---	1-3, 8
A	FR 2 496 969 A (GIRODIN TECH) 25 June 1982 see page 3, line 2 - line 6; figures 6, 7 ---	1, 2, 4
	-/--	

Further documents are listed in the continuation of box C.

Patent family members are listed in annex.

Special categories of cited documents:

- "A" document defining the general state of the art which is not considered to be of particular relevance
- "E" earlier document but published on or after the international filing date
- "L" document which may throw doubts on priority claim(s) or which is cited to establish the publication date of another citation or other special reason (as specified)
- "O" document referring to an oral disclosure, use, exhibition or other means
- "P" document published prior to the international filing date but later than the priority date claimed

- "T" later document published after the international filing date or priority date and not in conflict with the application but cited to understand the principle or theory underlying the invention
- "X" document of particular relevance; the claimed invention cannot be considered novel or cannot be considered to involve an inventive step when the document is taken alone
- "Y" document of particular relevance; the claimed invention cannot be considered to involve an inventive step when the document is combined with one or more other such documents, such combination being obvious to a person skilled in the art.
- "&" document member of the same patent family

Date of the actual completion of the international search

16 June 1998

Date of mailing of the international search report

23/06/1998

Name and mailing address of the ISA  
European Patent Office, P.B. 5818 Patentlaan 2  
NL - 2280 HV Rijswijk  
Tel. (+31-70) 340-2040, Tx. 31 651 epo nl,  
Fax: (+31-70) 340-3016

Authorized officer

Marti Almeda, R

# INTERNATIONAL SEARCH REPORT

International Application No

PCT/US 98/05365

**C.(Continuation) DOCUMENTS CONSIDERED TO BE RELEVANT**

Category	Citation of document, with indication, where appropriate, of the relevant passages	Relevant to claim No.
A	PATENT ABSTRACTS OF JAPAN vol. 014, no. 489 (E-0994), 24 October 1990 & JP 02 201906 A (MURATA MFG CO LTD), 10 August 1990, see abstract <p style="text-align: center;">----</p>	1,2,4
A	GB 1 401 741 A (SIEMENS AG) 30 July 1975 <p style="text-align: center;">-----</p>	

# INTERNATIONAL SEARCH REPORT

Information on patent family members

International Application No

PCT/US 98/05365

Patent document cited in search report		Publication date	Patent family member(s)	Publication date
WO 9719458	A	29-05-1997	SE 504592 C	10-03-1997
			AU 7715896 A	11-06-1997
			SE 9504204 A	10-03-1997
DE 4103297	A	13-08-1992	DE 4014118 A	14-11-1991
FR 2496969	A	25-06-1982	FR 2469786 A	22-05-1981
			FR 2474748 A	31-07-1981
			DE 3122949 A	15-07-1982
			JP 57114210 A	16-07-1982
GB 1401741	A	30-07-1975	DE 2213186 A	27-09-1973
			AT 326234 B	25-11-1975
			BE 796907 A	16-07-1973
			CH 554064 A	13-09-1974
			DD 102849 A	20-12-1973
			DE 2213118 A	20-09-1973
			FR 2176734 A	02-11-1973
			JP 49012364 A	02-02-1974
			NL 7303719 A	19-09-1973
			SE 382147 B	12-01-1976
			US 3982814 A	28-09-1976