

May 9, 1933.

H. REIMERS

1,908,445

POWDER DISTRIBUTING MACHINE

Filed June 21, 1930

2 Sheets-Sheet 1

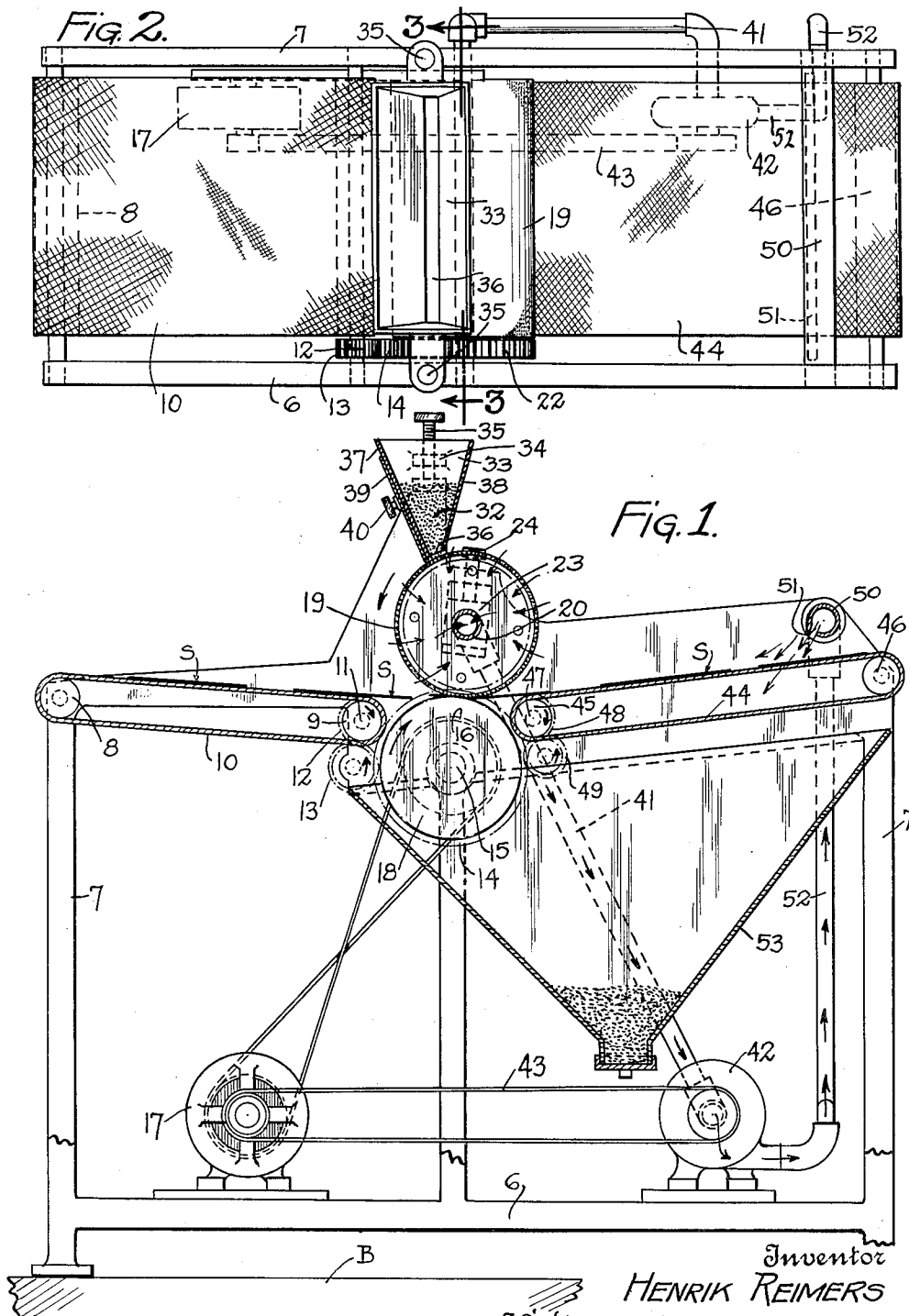

Fig. 1.

Fig. 2.

Inventor
HENRIK REIMERS
By His Attorney
Philip B. Koch

May 9, 1933.

H. REIMERS

1,908,445

POWDER DISTRIBUTING MACHINE

Filed June 21, 1930

2 Sheets-Sheet 2

Fig. 3.

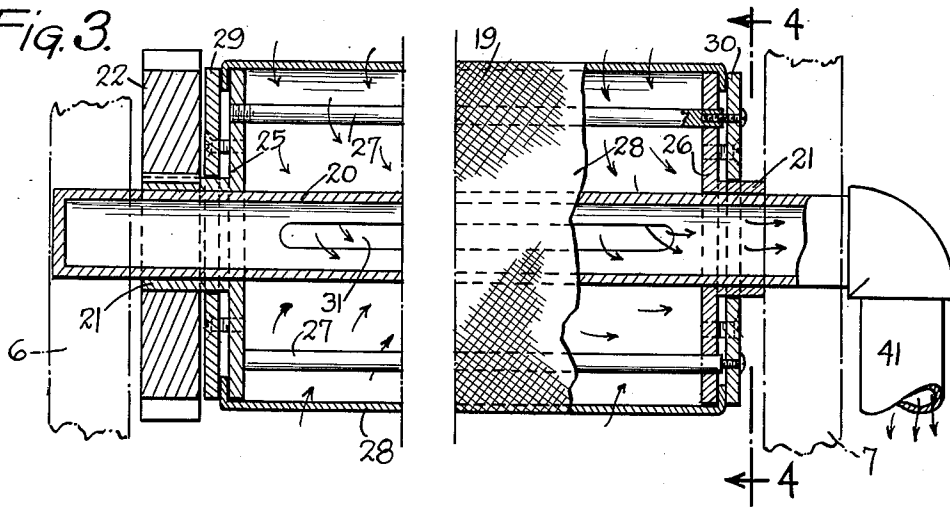

Fig. 4.

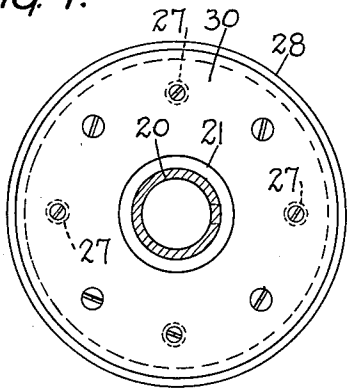
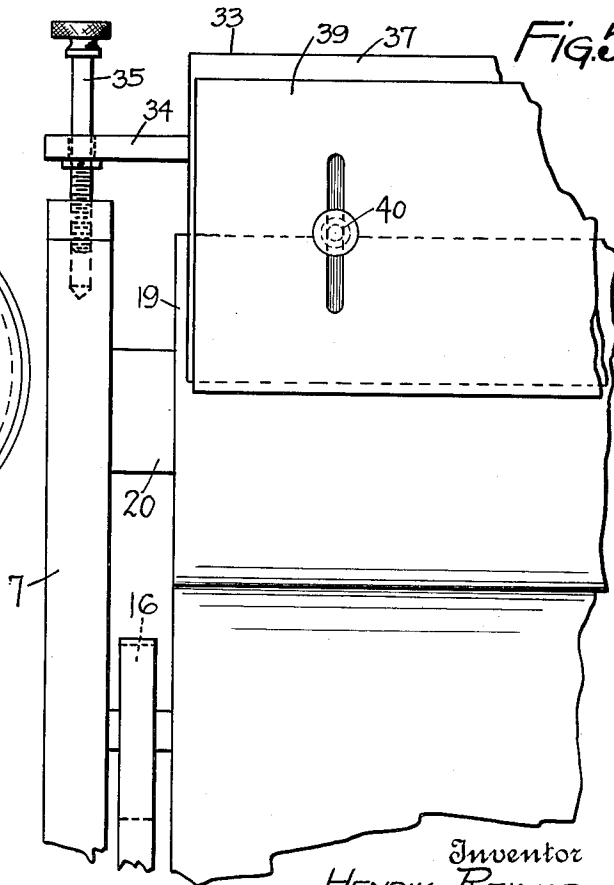

Fig. 5.



Inventor

HENRIK REIMERS

By His Attorney

Philip B. Koch

UNITED STATES PATENT OFFICE

HENRIK REIMERS, OF PLAINFIELD, NEW JERSEY

POWDER DISTRIBUTING MACHINE

Application filed June 21, 1930. Serial No. 462,715.

My invention relates more particularly to machines for spreading powder upon wet printed matter so that the printed characters become raised above the plane of the paper 5 thereby simulating engraved printing so closely as to make the product substantially indistinguishable from such work using steel dies or copper plates. Such process embossing or engraving as herein referred to 10 requires that the powder be applied to the print while the first impression is still wet so that such powder will adhere to the printed design. The superfluous powder that does not adhere to the freshly-inked 15 portions is then brushed, shaken or blown off, after which the powder-covered print is heated to a temperature sufficient to fuse or dissolve the powdered material and then the print is allowed to cool to complete the 20 process embossed product.

The objects of my invention are, among other things, to provide a new and improved machine for applying a film of powder directly to the wet printed matter in motion 25 by a simple, efficacious and economical mechanism. Such novel mechanism is designed to apply a uniform film of powder which is even to the ink without the necessity of covering the entire surface of the sheet 30 which is usually only partially printed or covered with wet ink, thereby avoiding to a large extent the requirement of removing surplus powder from the uninked portions as is indispensable where the powder is 35 applied by spraying or shaking methods customarily used to produce raised printing.

On such machines where the powder is shaken or sprayed on the sheets, a large amount of powder must be used to cover 40 the sheet completely, but by my improvements employing a vacuum roller or cylinder carrying a thin film of powder uniformly distributed on its peripheral surface, the powder leaves the roller and is applied to 45 the sheet only where there is wet ink on such sheet, the unprinted portions taking no powder from the powder applying roller. My improved machine renders it possible 50 to run large as well as small sheets at a relatively high speed, and also eliminates

the likelihood of the powder getting into the working parts of the machine, since there is very little surplus powder to be removed after the requisite amount has been applied to the wet ink portions of the sheets. 55

My improvements also comprehend a compact and inexpensive machine which is easy to operate and not likely to get out of order, and furthermore will run with a small amount of powder since a uniform film is directly applied only to the freshly-inked 60 portions of the sheets, and also other details of operation and apparatus which will be hereinafter fully described and then particularly pointed out in the claims. 65

In the annexed drawings Fig. 1 is a side elevation, partly in vertical section, of a preferred construction embodying my improvements;

Fig. 2 is a top plan view of the machine shown in Fig. 1; 70

Fig. 3 is an enlarged section taken on the line 3—3 of Fig. 2;

Fig. 4 is an end view taken on the line 4—4 of Fig. 3; and 75

Fig. 5 is a detail end view taken from the left side of Fig. 1.

Similar numerals refer to similar parts throughout the several figures.

Referring to the drawings, the side frames 6 and 7 are suitably mounted on any convenient base B and carry the transverse rollers 8 and 9 around which passes the feed-belt carrier 10 for the sheets S, preferably made of wire mesh and moving to the right 85 in Fig. 1. The shaft 11 of the roller 9 carries the gear 12 which is driven by the idler gear 13 which is driven by the gear 14 on the shaft 15 journaled in the side-frames 6 and 7. The shaft 15 carries the belted pulley 16 driven from the motor 17. 90

Mounted on the shaft 15 is the smooth-surfaced roller 18 which rotates in a clockwise direction as indicated by the arrow in Fig. 1. Above the roller 18 is the hollow suction roller 19 rotatably mounted on the hollow pipe 20 secured in the side-frames 6 and 7 (Fig. 3). The pipe 20 rotatably carries the sleeves 21 to one of which is keyed the gear 22 which meshes with the gear 14 100

on the shaft 15 to drive the suction roller 19 in an anti-clockwise direction as indicated by the arrow in Fig. 1. The pipe 20 is mounted in adjustable journal boxes 23 (one being shown in Fig. 1) regulated by the screw bolts 24 (only one being shown in Fig. 1) to vary the distance between the roller 18 and suction-roller 19 according to the thickness of the sheets fed therebetween and the character of the powder film on the roller 19.

The construction of the suction roller 19 may be widely varied: In the form shown, the inner heads 25 and 26 are mounted on the sleeves 21 and are held in spaced relationship by a series of axially-disposed rods 27 (Figs. 3 and 4).

Around the periphery of the suction-roller 19 and heads 25 and 26 is stretched a fine wire mesh 28 (preferably from 250 to 300 mesh) or bolt cloth which is held taut on the roller 19 by the clamping rings 29 and 30 fastened to the heads 25 and 26 respectively as well as to one end of the rods 27 by suitable screws as shown in Fig. 3. This construction for clamping the covering 28 on the suction-roller 19 enables the wire mesh or cloth covering 28 to be changed for varying degrees of fineness of the apertures required for different grades of powder as well as affording means for tightening same on the roller 19. The suction pipe 20 has cut therein the longitudinal slots 31 inside the heads 25 and 26 (only one being shown in Fig. 3).

The powder supply 32 is carried in the hopper 33 which extends transversely of the machine and is supported on brackets 34 extending outwardly from the hopper 33 (Figs. 2 and 5). The brackets 34 are carried by adjustable screw bolts 35 which are threaded in the side-frames 6 and 7 to raise or lower the hopper 33 relatively to the suction-roller 19. The hopper 33 is in the form of an inverted cone with a narrow slot 36 at the bottom formed between the converging side plates 37 and 38 which form the body of the hopper 33. The plate 37 carries the outer slidable plate 39 adjustably secured to the plate 37 by the set screws 40 (Figs. 1 and 5); such plate 39 serves to control the thickness and distribution of the film of powder deposited on, and covering, the mesh suction-roller 19 as the roller 19 is revolved beneath the hopper 33.

A vacuum or exhaust pressure is imparted to the interior of the suction-roller 19 whereby the film of powder deposited from the hopper 33 is held on the peripheral surface covering 28 of the roller 19. The suction pipe 20 is connected at one end to the pipe or rubber hose 41 attached to the combined suction fan and blower 42 (Fig. 1) driven by the belt 43 from the motor 17, whereby

air is drawn through the roller covering 28 as indicated by arrows in Figs. 1 and 3.

The sheet delivery carrier 44 is constructed like the feed-conveyor 10, preferably of wire-mesh, as shown in Fig. 2. The delivery conveyor 44 is carried by the transverse rollers 45 and 46 journaled in the side frames 6 and 7, the shaft 47 of the roller 45 carrying the gear 48 being driven by the pinion 49 which meshes with the gear 14 on the shaft 15. By this conveyor 44 the sheets S are advanced to the right in Fig. 1 beneath the transverse blow pipe 50 provided with the slotted orifice 51, the pipe 50 being connected by the pipe or hose 52 to the blower 42. The air blast from the pipe 50 removes any loose powder that has been deposited on the uninked portions of sheets and forces same into the open-mouthed tank 53 located below the rollers 18 and 19 and conveyor 44 as shown in Fig. 1. The blower 42 driven from the motor 17 not only maintains a continuous suction or exhaust pressure in the suction-roller 19, but also provides a continuous air-blast issuing from the pipe 50 as indicated by arrows in Figs. 1 and 3.

The operation of my machine is substantially as follows: The powder 32 of greater coarseness than the mesh or cloth covering 28 on the suction roller 19 is placed in the hopper 33, and the machine is started so that the film of powder deposited on the revolving roller 19 is uniformly distributed and held on the mesh or cloth covering 28, which, through the suction or exhaust pressure within the roller 19, enables the air to pass through the covering 28 but not the powder 32 because of the greater degree of fineness of the mesh covering 28.

The apparatus is preferably lined up with a printing-press so that the freshly-printed sheets S with the wet ink may be placed on the carrier 10, one by one, and carried into the bite of the rollers 18 and 19 where the wet ink portions of the sheets take the required amount of powder from the film on the suction roller 19; the uninked portions of the sheets do not remove any powder from the mesh covering 28 which contacts with the sheet with a positive but yielding pressure by which the film of powder is directly applied to the freshly-printed portions and not otherwise.

The sheets then pass forwardly on the delivery carrier 44 with the powder only on the wet ink portions and the air blast from the blow pipe 50 removes any powder that may have fallen from the film on the suction-roller 19 outside the zone of the sheet's wet ink portions, which surplus powder drops into the tank 53. The sheets S are then delivered to a carrier (not shown) running into and through a baking oven where the powder is fused with the ink, and

the finished product then emerges from the oven and is cooled in the regular way. The operation of the suction through the roller and air blast from the pipe 50 both connected with the blower 42 has been already described.

My machine is both simple in construction and economical in operation with powder applied only to the wet ink portions, and making it possible to use ordinary embossing powders with a uniform film even to the ink appearing on the sheets. My improvements are adapted to bronzing machines and all apparatus by which powder is to be applied to localized portions of any sheet material carrying adhesive to which the powder will stick when applied from this suction or vacuum roller.

Various changes in the construction and arrangement of the several parts shown and described may be made without departing from the scope of my invention or sacrificing its advantages in operation.

I claim as my invention:—

1. In a machine of the class described, a conveyor for a printed sheet and coating rollers between which the sheet is advanced by the conveyor, one of the rollers carrying a thereto exteriorly adhering film of powder held thereto throughout the entire periphery by suction maintained within the roller for pressing same only to the wet printed matter on the sheet, and means for varying the distance between said rollers to accommodate for different thicknesses of sheets.

2. In a machine of the class described, a conveyor for a printed sheet, a roller having a mesh peripheral surface adjacent the printed sheet advanced by the conveyor, means for depositing powder on the exterior peripheral surface of the roller, and means for maintaining a vacuum or exhaust pressure within the roller to hold a film of powder to the entire peripheral surface while applying same only to the wet printed matter on the sheet and retaining said film where contacting with unprinted matter.

3. In a machine of the class described, a conveyor for a printed sheet, coating rollers between which the freshly-printed sheet is advanced by the conveyor, one of the rollers having a mesh peripheral surface adjacent the printed sheet advanced by the conveyor, means for depositing powder on the exterior peripheral surface of the said mesh roller, means for maintaining a vacuum or exhaust pressure within the said mesh roller to hold a film of powder to the entire peripheral surface while applying same only to the wet printed matter on the sheet, while retaining the powder film in contact with the unprinted portions of the sheet and means for varying the distance between said rollers to

accommodate for different thicknesses of sheets.

4. In a machine of the class described, a conveyor for a printed sheet, a roller having a mesh peripheral surface adjacent the printed sheet advanced by the conveyor, means for depositing powder on the exterior peripheral surface of the roller, said mesh being of greater fineness than the powder deposited on the roller, and means for maintaining a vacuum or exhaust pressure within the roller to hold a film of powder to the entire peripheral surface while applying same only to the wet printed matter on the sheet and retaining said film where contacting with unprinted matter.

HENRIK REIMERS.

70

75

80

85

90

95

100

105

110

115

120

125

130