

D. MILLS.
Sewing Machine.

No. 101,644.

Patented April 5, 1870.

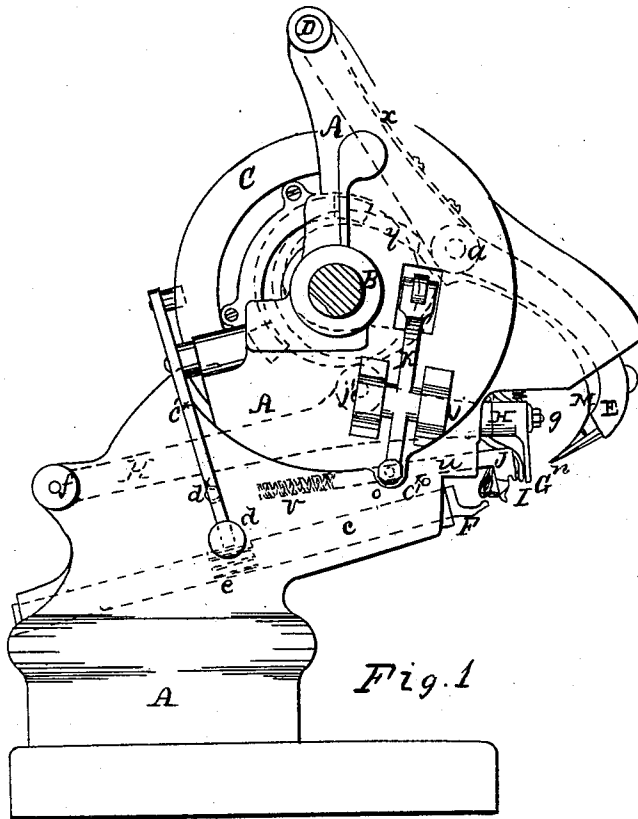

Fig. 3.



Fig. 5.

Witnesses

Wm. D. Bayley
Wm. H. Case

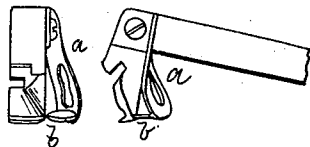

Inventor
Daniel Mills
by
A. Sollok
his atty

D. MILLS.
Sewing Machine.

No. 101,644.

Patented April 5, 1870.

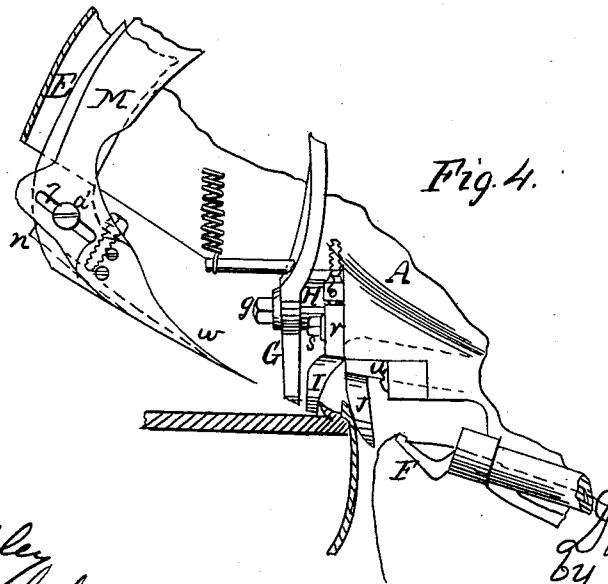
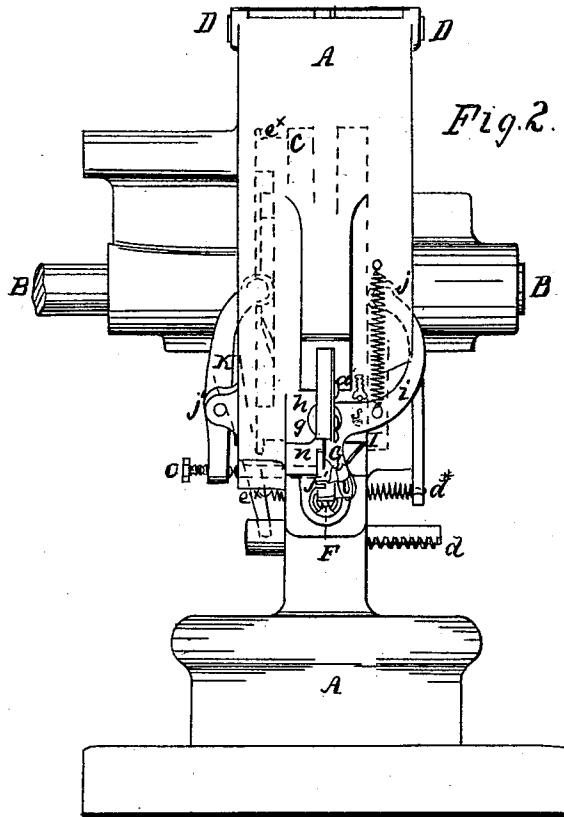

Witnesses

M. Bailey
Wm. W. Hale

Inventor

Daniel Mills
 by *A. Sollok*
 his atty

UNITED STATES PATENT OFFICE.

DANIEL MILLS, OF NEW YORK, N. Y.

IMPROVEMENT IN SEWING-MACHINE FOR BOOTS AND SHOES.

Specification forming part of Letters Patent No. 101,644, dated April 5, 1870.

To whom it may concern:

Be it known that I, DANIEL MILLS, of Brooklyn, in the county of Kings and State of New York, have invented certain new and useful Improvements in Sewing-Machines; and I hereby declare the following to be a full, clear, and exact description of the same, reference being had to the accompanying drawing, in which—

Figure 1 represents a sectional side elevation of a machine made in accordance with this invention; Fig. 2, a front view of the same.

Similar letters indicate corresponding parts.

This invention relates to sewing-machines which are intended particularly for "turned work," so called—*i. e.*, where the uppers of boots and shoes are sewed directly to their soles without the intermediary of welts, the work being inside out during the operation of sewing. This invention, however, may also be adapted for sewing on welts to insoles and uppers; and said invention consists, first, in so locating the fulcrum of the feed-lever as to be on a level with the work to be sewed, thereby causing the feed-dog to come down square upon the work, substantially as hereinafter shown and described; second, in the combination, with the vibratory feed-lever, of a feed-dog mounted upon the end of an elbow-lever, whose point of suspension is at the elbow, the relative position of the working-face of the feed-dog, the end of the lever, which is in contact with its operating cam-disk, and the fulcrum or pivot upon which said feed dog and lever vibrate, being such that the pivot and the end of the lever shall lie on opposite sides of a vertical plane passing through the working-face of the feed-dog at right angles with the line of feed; third, in the combination, with the yielding pressure-gage, of a locking device, to render said gage rigid at the proper intervals, as set forth; fourth, in the combination of the yielding pressure-gage with the lever actuated by the cam-disk and the set-screw passing through said lever for operation, substantially as herein shown and described, so that said gage can at all times be locked with the required degree of tightness; fifth, in a combined edge-gage and welt-guide, constructed and arranged substantially as herein shown and described, so that the inner edge

of the welt may be turned outward from the upper or work at the point where the stitching takes place, and be presented at a right angle to the needle, or nearly so, in order that the needle may squarely go through it, instead of going through it obliquely, as it would do if the welt were not so bent up.

In the drawing, A represents a frame, which forms the bearings for the shaft B, on which is mounted the cam-disk C, that imparts motion to the various parts of the sewing mechanism and its appurtenances. Through the upper part of the frame A extends a rod, D, which forms the fulcrum of a lever of the third order, E, and in the free end of this lever is secured the needle *n*, as shown in Fig. 1 of the drawing. An oscillatory motion is imparted to the lever E by a cam-groove in the disk C, the groove acting on a roller-stud secured to said lever between the needle and the fulcrum D, so that the moving force is applied to said lever at a point as close to the needle as possible, thus furnishing the power required to cause the needle to pass through leather or other thick material, and at the same time preventing said lever from springing sufficiently to disturb the correct operation of the sewing mechanism.

The thread is delivered to the needle by the action of the looper F, which is secured to a tubular arbor, *c*, to which a reciprocating revolving motion is imparted by the action of a rack, *d*, and pinion *e*, said rack receiving the required reciprocating motion by a cam-groove, *e**, in the periphery of the disk C, which connects with the rack by a lever, *e**'. The looper F, being made to extend eccentrically from the end of the tubular arbor *c*, partakes of the reciprocating motion of said arbor, and in doing so it carries the thread round the barb of the needle. The tubular arbor *c* extends through a cavity in the bottom part of the frame A, and it is exposed to the flame of a lamp or gas-burner, a draft-hole, *e**', being provided in the upper end of said cavity, so that the waxed thread, in passing through said tubular arbor, becomes heated and pliable. The pinion *e* is either keyed to the arbor *c*, or it is produced by cutting-teeth in the circumference of said arbor, and the reciprocating motion of the rack *d* is facilitated by the action

of a spring, d^* , connected to the lever e^* , as shown in the drawing. The required feed-motion is imparted to the work by the feed-dog G, which has its fulcrum on the free end of the lever H, and receives an oscillating motion by the action of a cam on the side of the disk C. The lever H, that carries the feed-lever, has its fulcrum on a pivot, f , situated on a level with the work, and it receives an oscillating motion by a cam mounted on the shaft B.

By placing the fulcrum of the lever that supports the feeding-dog on a level with the work, its point is brought down squarely upon said work, which is not the case if the fulcrum be situated higher or lower than the level of the work, and the oscillating motions of the feed-dog and of the lever are so timed that the feed-dog is first brought down upon the work by the action of the feed-lever, then receives its oscillating motion, so as to push the work along. It is then raised from the work and carried back to its original position, ready for the subsequent feed.

The connection between the feed-dog and lever is effected by a pivot, g , projecting from the free end of the lever, and passing through an eye, h , formed in the elbow of the feed-dog at the point farthest removed from the arm i , which carries a roller, j , that acts against the cam on the side of the disk C. Said eye or pivot is so situated in relation to the working face of the feed-dog and to the roller-arm i that it lies on that side of a vertical plane passing through the working-face of the feed-dog opposite to that on which the roller-arm i is situated, whereby the pressure of the feed-dog against the work has a tendency to keep the roller j in contact with its cam, thus rendering the feed motion sure and uniform.

This machine is intended particularly for sewing the uppers of boots and shoes to the soles, in what is technically known as turned work, and the work is turned inside out, and put on a last in the usual manner, a channel being made in the inner surface of the sole to receive the stitches, as indicated in Fig. 3, at a and b , where the work is shown before and after it is turned.

The last is secured in a last-holder, which is placed on a table, (not shown in the drawing,) and said table is forced up by means of a spring or weight, so that the work will be pressed up against the surface-gage I. This gage is secured to the edge of the frame, and it is provided with side flanges r , which overlap the edges of the frame and prevent the gage from swinging out sidewise. A screw, s , retains the gage in position, and another screw, t , which bears on the top edge of said gage, serves to adjust the same up and down, so that the work will be presented to the needle in the proper position, as more clearly shown in Fig. 4, which represents a side view of the parts last referred to.

The correct position of the work is further

insured by the edge-gage J, which is secured to the outer end of a pin or slide, u , fitted into a cavity in the frame A, and subjected to the action of a spring, v , which keeps said gage in contact with the edge of the work, and allows the same to follow the sinuosities thereof.

This edge-gage also serves to retain the work against the thrust of the needle, and to effect this purpose a locking-lever, K, is applied, which is operated by a cam in the side of the disk C.

This lever has its fulcrum on a pivot, j' , secured in a lug projecting from the frame A, and it carries a set-screw, o , which acts on the slide u of the edge-gage at the proper interval, and serves to retain the same firmly in position while the needle passes through the work. By adjusting the set-screw the locking-lever can be made to do its work with great precision, and without fail.

Although this machine is, as before said, particularly adapted to "turned work," it can also be used for welt-sewing by the appliance of a welt-guide to the edge-gage. At one side of the latter, and rigidly connected, is a slotted piece of sheet metal, of angular formation, as shown in front and side elevation in Fig. 5.

The face a of the welt-guide is so inclined in relation to the face b , and the slot therein so formed, that the inner edge of the welt, which is or may be fed from a strip of any length, is bent or turned outward from the upper or work at the point where the stitching takes place, and is presented at right angles, or nearly so, to the needle. In this way the needle will go squarely through the welt, instead of going obliquely through, as it would do if the belt were not so bent up.

The correct operation of the needle in retaining and releasing the loop of the thread at the proper intervals, is insured by the barb-coverer w , which is secured to a lever, M.

This lever has its fulcrum on the rod D, in the top of the frame A, and it is situated close to the side of the needle-lever E, and subjected to the action of a spring, x , which is secured to the edge of the needle-lever.

A cam on the shaft B acts on the lever M, and serves to impart to the barb-coverer its own distinct motion, as will be presently explained.

The free end of the lever M is provided with an oblong slot, z , through which passes a screw, a , which is secured in the needle-lever, as seen in Fig. 4. The motion of the barb-coverer in relation to the needle is as follows:

When the needle enters the work, the barb-coverer is resting against the work, being pressed up by the spring x , which is fastened to the needle-lever. When the needle recedes, the barb-coverer remains stationary until the barb is covered. Then the set-screw a' in the needle-lever strikes the end of the slot z in the lever M, and carries the barb-coverer up with it until near the outer end of its motion,

when the barb-coverer receives an additional outward movement by its own cam, and is retained there while the needle comes back, and it does not overtake the needle until the same is near entering its work again.

By these means the loop is prevented from slipping out of the barb while the needle is out, and as soon as the needle moves in the barb is uncovered, and the loop is free to drop out, and the barb-coverer does not move in until the loop has been carried out of the way by the feed motion imparted to the work.

Having now described this invention, and the manner in which the same is or may be carried into effect, what I claim, and desire to secure by Letters Patent, is—

1. The vibrating lever, carrying the feeding-dog and pivoted on a level with the work to be sewed, whereby the feed-dog is caused to come down squarely upon the work, substantially as herein shown and described.

2. The vibrating lever, in combination with the feeding-dog, formed substantially like an elbow-lever and pivoted at its elbow, and so shaped that the arm of the elbow-lever in contact with the operating cam-disk and the working face of the feed-dog lie on the same side of the pivotal point of the elbow-lever, so that, when the dog rests on the material, its pressure thereon tends to throw the opposite

end of the elbow-lever against its actuating-cam.

3. The combination, with the yielding pressure-gage, of the locking-mechanism, constructed as described, to render said gage rigid at the proper intervals, as set forth.

4. The combination of the yielding pressure-gage with the lever, actuated by the cam-disk and the set-screw passing through said lever, for operation substantially as herein shown and described, so that said gage can at all times be locked with the required degree of tightness.

5. A combined edge-gage and welt-guide, constructed and arranged substantially as herein shown and described, so that the inner edge of the welt may be turned outward from the upper or work at the point where the stitching takes place, and be presented at a right angle to the needle, or nearly so, in order that the needle may go squarely through it instead of going through it obliquely, as it would do if the welt were not so bent up.

In testimony whereof I have signed my name to this specification before two subscribing witnesses.

DANL. MILLS.

Witnesses:

M. BAILEY,
A. POLLOK.