

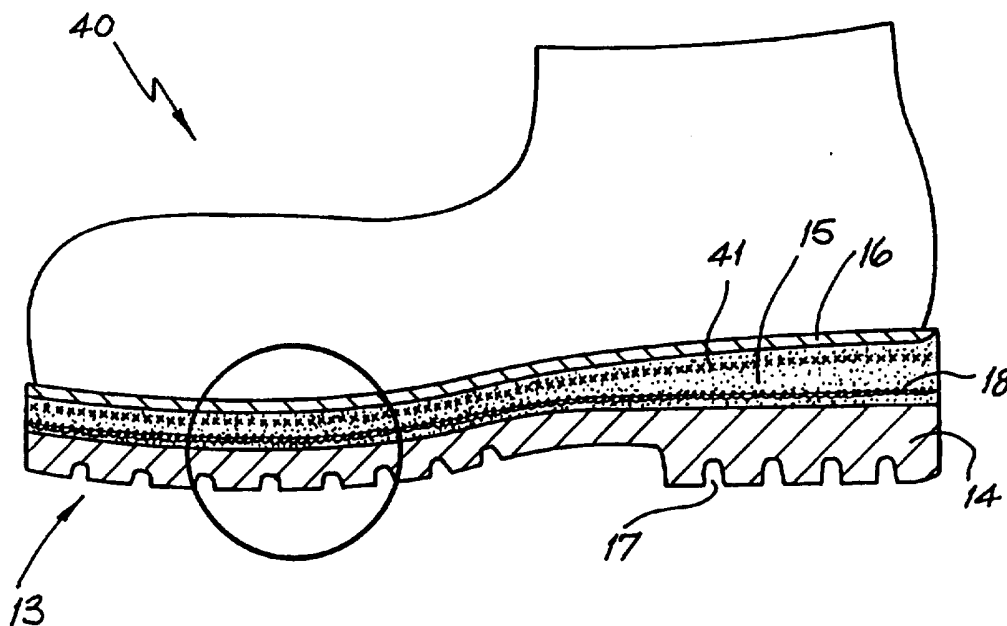

INTERNATIONAL APPLICATION PUBLISHED UNDER THE PATENT COOPERATION TREATY (PCT)

<p>(51) International Patent Classification <sup>6</sup> : A43B 7/32, 13/12</p>	<p>A1</p>	<p>(11) International Publication Number: <b>WO 96/26655</b> (43) International Publication Date: 6 September 1996 (06.09.96)</p>
<p>(21) International Application Number: PCT/SG96/00001 (22) International Filing Date: 28 February 1996 (28.02.96) (30) Priority Data: 95-00037-8 1 March 1995 (01.03.95) SG (71)(72) Applicant and Inventor: VAZ, Guy, Andrew [SG/SG]; 20 Pasir Ris Heights, Singapore 519227 (SG). (74) Agent: WONG PARTNERSHIP; 298 Tiong Bahru Road #18-01/06, Tiong Bahru Plaza, Singapore 168730 (SG).</p>	<p>(81) Designated States: AL, AM, AT, AU, AZ, BB, BG, BR, BY, CA, CH, CN, CZ, DE, DK, EE, ES, FI, GB, GE, HU, IS, JP, KE, KG, KP, KR, KZ, LK, LR, LS, LT, LU, LV, MD, MG, MK, MN, MW, MX, NO, NZ, PL, PT, RO, RU, SD, SE, SG, SI, SK, TJ, TM, TR, TT, UA, UG, US, UZ, VN, ARIPO patent (KE, LS, MW, SD, SZ, UG), Eurasian patent (AM, AZ, BY, KG, KZ, MD, RU, TJ, TM), European patent (AT, BE, CH, DE, DK, ES, FR, GB, GR, IE, IT, LU, MC, NL, PT, SE), OAPI patent (BF, BJ, CF, CG, CI, CM, GA, GN, ML, MR, NE, SN, TD, TG).</p> <p><b>Published</b> <i>With international search report. Before the expiration of the time limit for amending the claims and to be republished in the event of the receipt of amendments.</i></p>	

(54) Title: BLAST AND FRAGMENT RESISTANT POLYURETHANE BOOT SOLE FOR SAFETY FOOTWEAR



(57) Abstract

A blast and fragment resistant polyester or polyether-based polyurethane boot sole (13) is described, comprising embedded protective material composed of at least one woven polyaramid (Kevlar) layer (18). One or more layers of graphite fibres, ceramic fibres, S-glass fibres or mineral fibres may be also interwoven with or placed between the polyaramid layers.

**FOR THE PURPOSES OF INFORMATION ONLY**

Codes used to identify States party to the PCT on the front pages of pamphlets publishing international applications under the PCT.

AM	Armenia	GB	United Kingdom	MW	Malawi
AT	Austria	GE	Georgia	MX	Mexico
AU	Australia	GN	Guinea	NE	Niger
BB	Barbados	GR	Greece	NL	Netherlands
BE	Belgium	HU	Hungary	NO	Norway
BF	Burkina Faso	IE	Ireland	NZ	New Zealand
BG	Bulgaria	IT	Italy	PL	Poland
BJ	Benin	JP	Japan	PT	Portugal
BR	Brazil	KE	Kenya	RO	Romania
BY	Belarus	KG	Kyrgystan	RU	Russian Federation
CA	Canada	KP	Democratic People's Republic of Korea	SD	Sudan
CF	Central African Republic	KR	Republic of Korea	SE	Sweden
CG	Congo	KZ	Kazakhstan	SG	Singapore
CH	Switzerland	LI	Liechtenstein	SI	Slovenia
CI	Côte d'Ivoire	LK	Sri Lanka	SK	Slovakia
CM	Cameroon	LR	Liberia	SN	Senegal
CN	China	LT	Lithuania	SZ	Swaziland
CS	Czechoslovakia	LU	Luxembourg	TD	Chad
CZ	Czech Republic	LV	Latvia	TG	Togo
DE	Germany	MC	Monaco	TJ	Tajikistan
DK	Denmark	MD	Republic of Moldova	TT	Trinidad and Tobago
EE	Estonia	MG	Madagascar	UA	Ukraine
ES	Spain	ML	Mali	UG	Uganda
FI	Finland	MN	Mongolia	US	United States of America
FR	France	MR	Mauritania	UZ	Uzbekistan
GA	Gabon			VN	Viet Nam

**BLAST AND FRAGMENT RESISTANT  
POLYURETHANE BOOT SOLE FOR SAFETY FOOTWEAR**

Field of the Invention

5           The present invention relates to the construction of a boot sole, and more particularly pertains to a new and improved safety boot sole construction to prevent puncturing of the sole by high energy and high velocity projectiles thus affording greater protection to an individual's foot without over-restricting movement.

10          Description of the Prior Art

          U.S. Patent no. 5,237,758 to Zachman: this uses semi-elliptical sections intersecting at loops with adjacent webs of adjacent loops intersecting with flexible rods directed through the intersecting loops to minimise lateral displacement of adjacent webs.

15           U.S. Patent no. 5,285,583 to Aleven: this uses a protective layer composed of plastic and including a flexible forepart portion having an insole board bonded to its bottom surface and a fabric liner bonded to its top surface during the process of moulding the protective plastic layer. The plastic used by Aleven is molten plastic injected in the final bonding process.

20           International Patent DE 4214802, by ZEPF H, to SPORTARTIKELFABRIK UHL GMBH KARL: A multi-layer boot sole having a walking surface, a damping intermediate sole, and an upper insole. The base is a thermo-plastic moulding, or is made of metal, ceramic or graphite, in which multi-filament organic or inorganic reinforcing fibres are embedded in the form of a mat, or woven or knitted into the structure. The elastic profiled portions are formed on the underside of the base by injection moulding or pressing. The base can contain only a single layer of woven  
25           fibres, its total thickness being approximately 0.5 mm.

          Aleven achieved strength and impact resistance from a plastic plate in the sole and the use of a fabric mesh was to reinforce the plastic and not to provide impact  
30           resistance. ZEPF H, could only achieve a single layer of not more than 0.5 mm thickness of woven fibres through injection moulding or pressing. Aleven made no discussion of metal, ceramic or graphite materials. So far, techniques to use aramid,

ceramic, or graphite fibres in the construction of a boot sole in thicknesses to prevent puncturing of the sole by high energy and high velocity projectiles has not been mentioned or made feasible due to problems in rigidity and bonding.

5 Summary of the Invention

The boot soles described in the prior art are insufficient against blast and projectile protection when it is desired to conserve toe-to-heel flexion in order to enable running, jumping and to clear obstacles such as rope ladders, rope climbing, small steps, and with sufficient feel or sensitivity to detect edges, pits, and small stones. To attain this, the present invention provides a blast and fragment resistant polyester and/or polyether-based polyurethane boot sole comprising embedded protective material in which the material is embedded throughout the entire sole and is composed of at least one woven polyaramid (Kevlar) layer, the density of which is less than or equal to 15 oz per square yard. Increasing density and additional layers of woven polyaramid fibres increases the blast and fragment resistance.

10 It is also an object of the present invention to provide a boot sole with good adhesion between the various polyaramid (Kevlar) layers and/or graphite fibre bundles in spite of the poor intrinsic adhesion between the polyaramid fibres, graphite fibres, and the polyurethane. Due to the extremely thin coating of the various polyaramid (Kevlar) and/or graphite fibre bundles prior to weaving and/or due to the relatively loose or coarse weave of the polyaramid (Kevlar) fibres, the polyurethane is able to penetrate between the fibres, allowing the various layers to be well bonded together, thereby preventing the peeling apart of the sole in subsequent use.

20 According to the invention, polyaramid (Kevlar) and/or graphite fibres can be coated thinly with polyester or polyether based polyurethane before they are woven into the required mat form, this will greatly improve adhesion between the polyaramid and polyurethane material.

Also according to the invention, polyester fibres, preferably poly(ethylene terephthalate) (PET) fibres, can be interwoven with or between the (coated or uncoated) polyaramid (Kevlar) fibres to improve adhesion between the polyaramid and polyurethane material.

30

Also according to the invention, carbon graphite fibres can be interwoven with or between the polyaramid (Kevlar) layers to further strengthen and to stiffen the sole.

Also according to the invention, a woven layer of mineral fibres, notably ceramic fibres or S-glass fibres, can be included into the boot sole to act as a fire wall for protection against hot gasses with temperatures of between 815 and 1,650 degrees Celsius.

#### Brief Description of the Drawings

The invention will be better understood and objects other than those set forth above will become apparent when consideration is given to the following detailed description thereof. Such description makes reference to the annexed drawings wherein:

Figure 1 is a vertical cross-sectional view of a boot having a first embodiment of the sole construction according to the present invention;

Figure 1-A is an enlarged view of the sole construction of Figure 1;

Figure 2 is a vertical cross-sectional view of a boot having a second embodiment of the sole construction according to the present invention;

Figure 2-A is an enlarged view of the sole construction of Figure 2;

Figure 3 is a vertical cross-sectional view of a boot having a third embodiment of the sole construction according to the present invention;

Figure 3-A is an enlarged view of the sole construction of Figure 3;

Figure 3-B is an enlarged view of an alternative sole construction to that depicted in Figure 3-A;

Figure 4 is a vertical cross-sectional view of a boot having a fourth embodiment of the sole construction according to the present invention;

Figure 4-A is an enlarged view of the sole construction of Figure 4; and

Figure 4-B is an enlarged view of an alternative sole construction to that depicted in Figure 4-A.

#### Description of the Preferred Embodiments

A boot having a first embodiment of the sole construction according to the

present invention is generally depicted as 10 in Figures 1 and 1-A.

The boot 10 has a standard shaped upper portion 11 and a composite sole 13. The composite sole 13 comprises an outer polyurethane sole 14 having a tread 17, an intermediate sole 15 into which is embedded a layer of polyaramid fibres 18, and  
5 optionally, an upper sole 16.

The composite safety boot sole is made in a traditional multi-stage mould which is commonly used in the polyurethane shoe soling industry.

The polyester and/or polyether-based polyurethane is first injected into a composite sole mould cavity to form the outer (lower) sole 14 such that its density is  
10 typically in the range of 500 to 2000 kg/m<sup>3</sup>.

After removal of the top plate of the mould for the outer (lower) sole, one thick layer of polyaramid (Kevlar) woven fibre material 18 is placed onto the outer (lower) sole 14 which remains in the mould cavity.

The polyaramid (Kevlar) fibre material can be precoated with polyester and/or  
15 polyether-based polyurethane prior to weaving. The coat of polyurethane serves to facilitate good adhesion with and penetration by polyurethane which is injected into the mould cavity.

The density of the polyaramid layer 18 is at least 5 oz per square yard, preferably 15 oz per square yard, for each ply of woven polyaramid material.

This thick polyaramid layer 18 preferably consists of bundles of polyaramid in  
20 crowfoot or leno weave with 70% to 90% in the X to Y direction (that is perpendicular to toe-to-heel), and 10 to 30% in the toe-to-heel direction.

The thickness of the layer of the polyaramid layer 18 is at least 0.07 inches, more typically 0.11 inches, using Kevlar 49 in 7100 denier bundles with tensile  
25 strength of 43,000 PSI and modulus 19 million PSI with a 0.07 inch diameter polyaramid fibres.

After placement of the polyaramid layer 18, polyester and/or polyether-based polyurethane is injected into the mould cavity containing the outer (lower) sole 14 at the base of the sole to form the intermediate sole 15. The polyurethane after injection  
30 into the mould has a typical density of < 1000 kg/m<sup>3</sup>.

Due to the penetration of the polyurethane into and through the polyaramid

layer 18 good adhesion is achieved between the outer (lower) and sole 14 and intermediate sole 15, with the polyaramid layer 18 sandwiched in between.

At this stage, the upper portion 11 can be directly attached to the polyurethane composite sole 13 comprising of the outer (lower) and intermediate soles 14, 15 or a  
5 third upper sole 16 can be added on top of the intermediate sole for enhanced comfort. In this latter case, the outer (lower) and intermediate soles 14, 15 as described above are left in the mould cavity and polyester and/or polyether-based polyurethane is injected into the mould cavity, directly on top of the intermediate sole 15.

A shoe sole 13 made according to the above method with the preferred 15 oz  
10 per square yard polyaramid layer 18 is effective in providing blast and fragment resistance to 60 grain projectile with a velocity of 1350 fps. It also conserves good toe-to-heel flexion in order to enable running, jumping and to clear obstacles such as rope ladders, rope climbing and small steps, while avoiding delamination of the sole in subsequent use.

15 A boot having a second embodiment of the sole construction according to the present invention is depicted as 20 in Figures 2 and 2-A.

In this embodiment, where like features have the same reference number as used above, the sole 13 has further layers 18 of polyaramid fibre material incorporated therein.

20 As is depicted in Figure 2-A, the outer sole can have up to two layers of polyaramid fibre 18. The intermediate sole 15 would typically have between 2 and 6 layers of polyaramid fibre, with three layers being a typical number as is shown in Figure 2-A.

25 To fabricate the sole as depicted in Figures 2 and 2-A, 2 layers of the polyaramid woven layers 18 are placed into the mould cavity which forms the outer (lower) sole 14.

The polyaramid layers 18 consist preferably of polyaramid fibres being of 0.01 inch diameter. The fibres are woven together to form a layer less than 0.06 inches thick and, more typically, about 0.04 inches thick.

30 A polyester and/or polyether-based polyurethane is then injected into a composite shoe sole mould cavity to form the outer (lower) sole 14 such that its

density is typically in the range of 500 to 2000 kg/m<sup>3</sup>.

After removal of the top plate of the mould for the outer (lower) sole 14, a further 2 to 6 layers of the same polyaramid (Kevlar) woven material 18 as embedded into the outer (lower) sole 14 is placed onto the outer (lower) sole 14 which remains  
5 in the base of the mould cavity.

At this stage a polyester and/or polyether-based polyurethane is injected into the mould cavity to form the intermediate sole 15 such that the polyurethane has a typical density of < 1000 kg/m<sup>3</sup>.

Due to the penetration of the polyurethane into and through the polyaramid  
10 layers 18 good adhesion is achieved between the outer (lower) and intermediate soles 14, 15 with the polyaramid layers 18 sandwiched in between.

At this stage, the upper portion 11 can be directly attached to the polyurethane composite sole 13 comprising of the outer (lower) and intermediate soles 14, 15 or a third, upper polyurethane sole 16 can be included for enhanced comfort. This is  
15 achieved by allowing the outer and intermediate soles (made by the process above) to remain in the mould cavity and by injecting polyester and/or polyether-based polyurethane onto the intermediate sole 15.

A shoe sole made according to the above method is even more effective in providing blast and fragment resistance than the first embodiment due to the multiple  
20 polyaramid layers.

In a third embodiment of this invention, the polyaramid layers 18 as described in relation to soles depicted in Figures 1 and 2 are interwoven with polyester (PET) fibres and the boot sole is made in the same manner as described above.

The use of interwoven polyaramid and polyester (PET) fibres has the advantage  
25 of further increasing the adhesion of the polyurethane material to the embedded layer(s) 18. This being due to the intrinsically superior adhesion between polyurethane and polyester.

In a fourth embodiment of this invention, the polyaramid layers 18 as described in the embodiments above are further interwoven with carbon graphite fibres having  
30 12K TOW and a tensile strength of 470,000 PSI and modulus of 35 million PSI with the boot sole 13 being made in the same manner as described above.

The use of interwoven carbon graphite fibres has the advantage of further increasing strength and stiffness and of improving wear resistance.

In a further embodiment of the invention depicted generally as 30 in Figures 3 and 3-A boot sole 13 is made as described above except that, in addition, a layer of woven ceramic fibres of composite ceramic/polyaramid fibres 31 are included into the intermediate sole 15.

The woven ceramic fibre layer is preferably comprised of 0.05 inch diameter ceramic fibres with 70% to 90% of the ceramic fibres being woven into a crowfoot or leno weave in the X-Y direction (perpendicular to the toe-to-heel direction) and with 10% to 30% of ceramic fibres in the toe-to-heel direction. This layer is embedded in the intermediate sole above the polyaramid (Kevlar) layer(s) 18 (see Figure 3-A). In an alternative arrangement, as depicted in Figure 3-B, a thin (0.025 inch) composite layer 32 of ceramic/polyaramid fibres preferably consisting of standard bidirectional weave can be embedded in the upper sole 16.

The boot sole incorporating this composite layer of ceramic/polyaramid fibres 32 allows for protection against hot gasses, with a temperature resistance of 1,650 degrees Celsius during the very brief duration of the blast.

In a further embodiment 40 of this invention, a layer of composite S-Glass fibres can be added into the middle or upper sole 14, 15 (see Figures 4, 4-A and 4-B).

A layer 41 of 0.05 inch diameter ceramic fibres, where 70% to 90% of the S-Glass fibres are woven into a crowfoot or leno weave in the X-Y direction (perpendicular to the toe-to-heel direction) and with 10% to 30% of S-Glass fibres in the toe-to-heel direction, is embedded in the intermediate sole above the polyaramid (Kevlar) layer(s) 18 (Figure 4-A). Alternatively, a thinner (0.025 inch) layer 42 of S-Glass fibres preferably having a standard bi-directional satin weave can be embedded in the upper sole 16 (Figure 4-B).

The boot sole 13 incorporating the layer of S-Glass fibres 41, 42 allows for protection against hot gasses with a temperature resistance of 815 degrees Celsius for the very brief duration of the blast.

As to the manner of usage and operation of the instant invention, the same should be apparent from the above disclosure and accordingly no further discussion

relative to the manner of usage and operation of the instant invention shall be provided.

5 With respect to the above description, it is to be realised that the optimum dimensional relationships and materials for the parts of the invention, to include variations in size, materials, shape, form, function and manner of operation, assembly and use, are deemed readily apparent and obvious to one skilled in the art, and all equivalent relationships to those illustrated in the drawings and described in the specifications are intended to be encompassed by the present invention.

10 Therefore, the foregoing is considered as illustrative only of the principles of the invention. Further, since numerous modifications and changes will readily occur to those skilled in the art it is not desired to limit the invention to the exact construction and operation shown and described and accordingly, all suitable modifications and equivalents may be resorted to falling within the scope of the invention.

CLAIMS

1. A blast and fragment resistant polyester or polyether-based polyurethane boot sole comprising embedded protective material characterised in that the material is embedded through the entire sole and is composed of at least one woven polyaramid (Kevlar) layer, the density of which is less than or equal to 15 oz per square yard.
2. The sole according to claim 1, characterised in that the embedded material consists of one thick polyaramid (Kevlar) woven layer, the thickness of which is at least 0.07 inches.
3. The sole of claim 2 wherein the thick polyaramid layer consists of bundles of polyaramid in crowfoot or leno weave with 70% to 90% in the X-to-Y direction and 10% to 30% in the toe-to-heel direction.
4. The sole according to claim 1 characterised in that the embedded material includes at least 3 polyaramid (Kevlar) woven layers, the thickness of each layer being less than 0.06 inches, bonded together by the polyurethane material.
5. The sole according to any one of the above claims characterised in that the polyaramid fibres comprising the polyaramid (Kevlar) layers are interwoven with polyester (PET) fibres.
6. The sole according to any one of the above claims characterised in that the polyaramid fibres are thinly coated with polyester and/or polyether based polyurethane prior to weaving.
7. The sole according to any one of the above claims characterised in that the polyaramid fibres comprising the polyaramid (Kevlar) layers are interwoven with carbon graphite fibres.

8. The sole according to any one of the claims 1 to 6 characterised in that the embedded material includes at least one layer of carbon graphite fibres.
9. The sole according to any one of the above claims characterised in that the  
5 embedded materials include at least one layer of mineral fibres.
10. The sole according to claim 9 characterised in that the mineral fibres consist of ceramic fibres.
- 10 11. The sole according to claim 9 characterised in that the mineral fibres consist of S-Glass fibres.

1/4

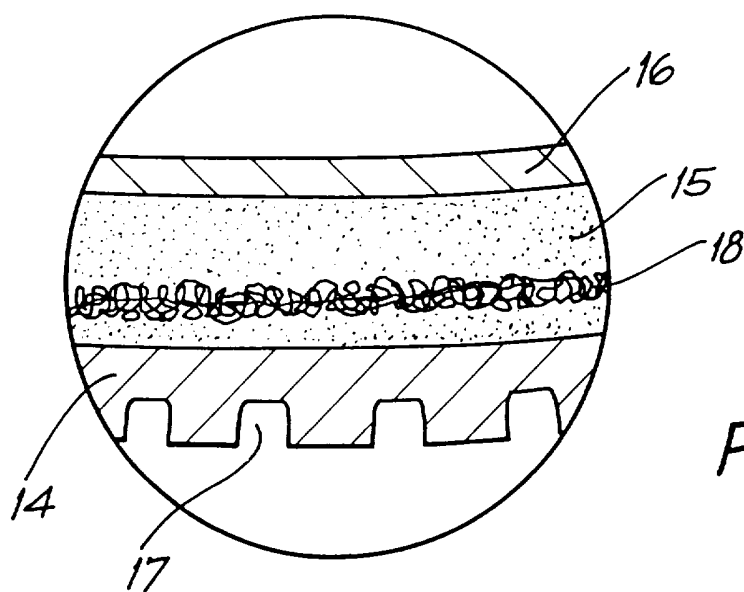
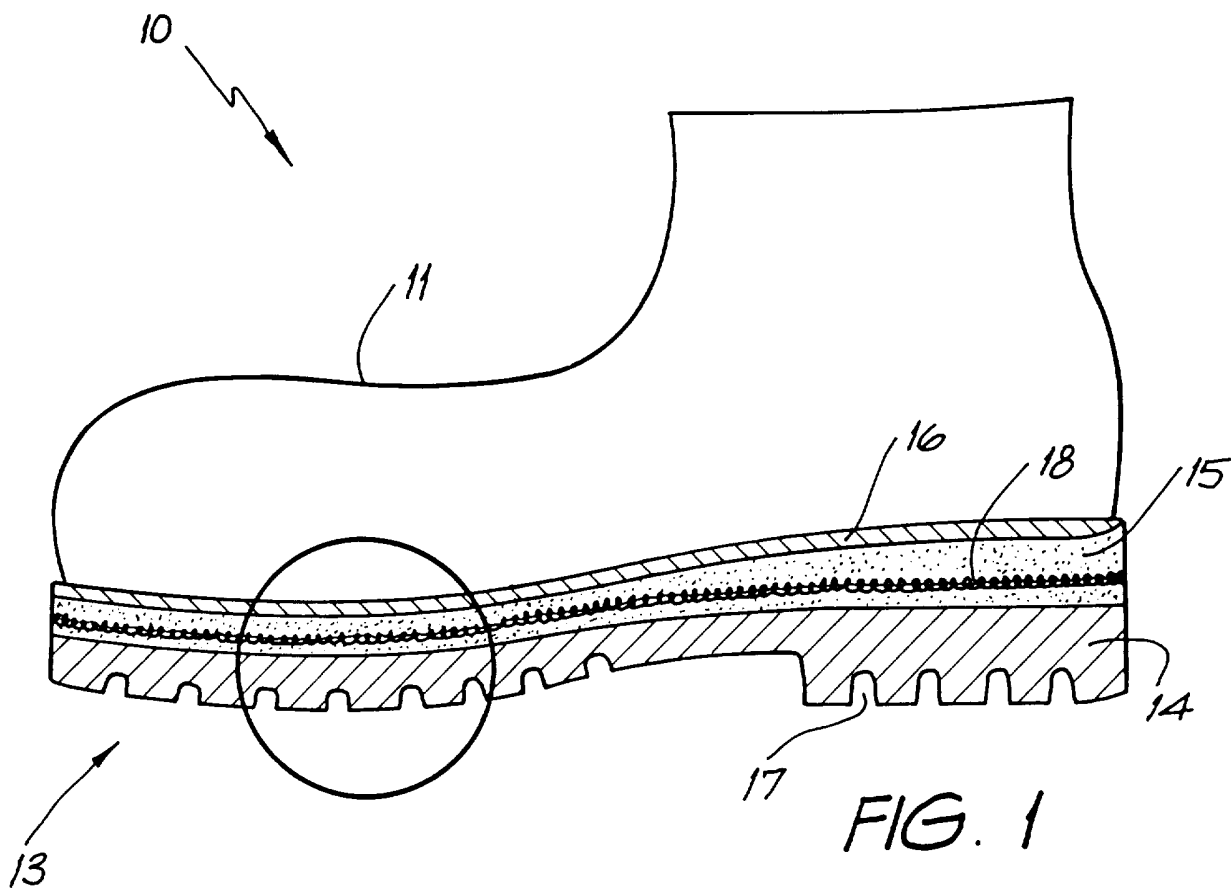

2/4

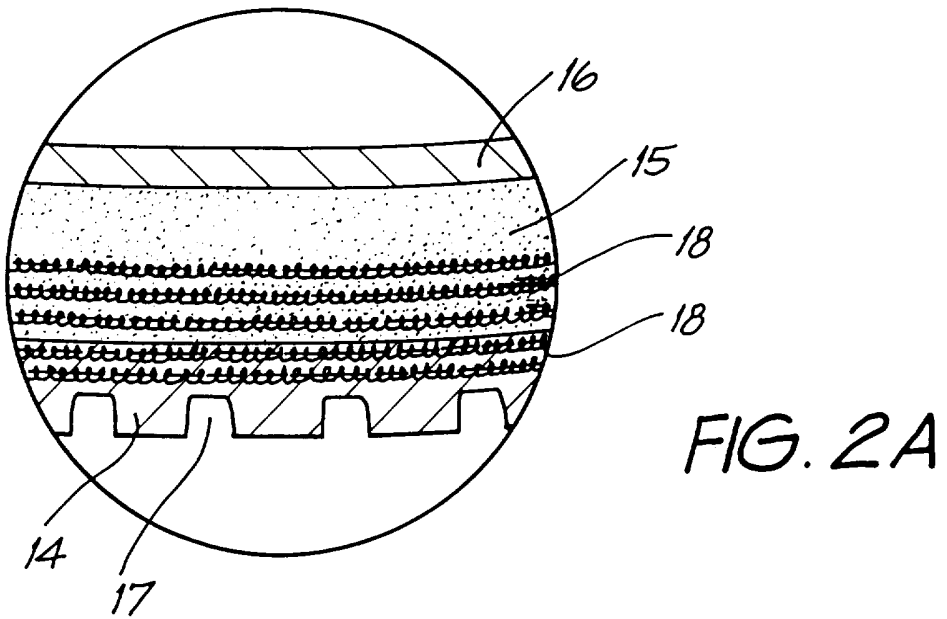
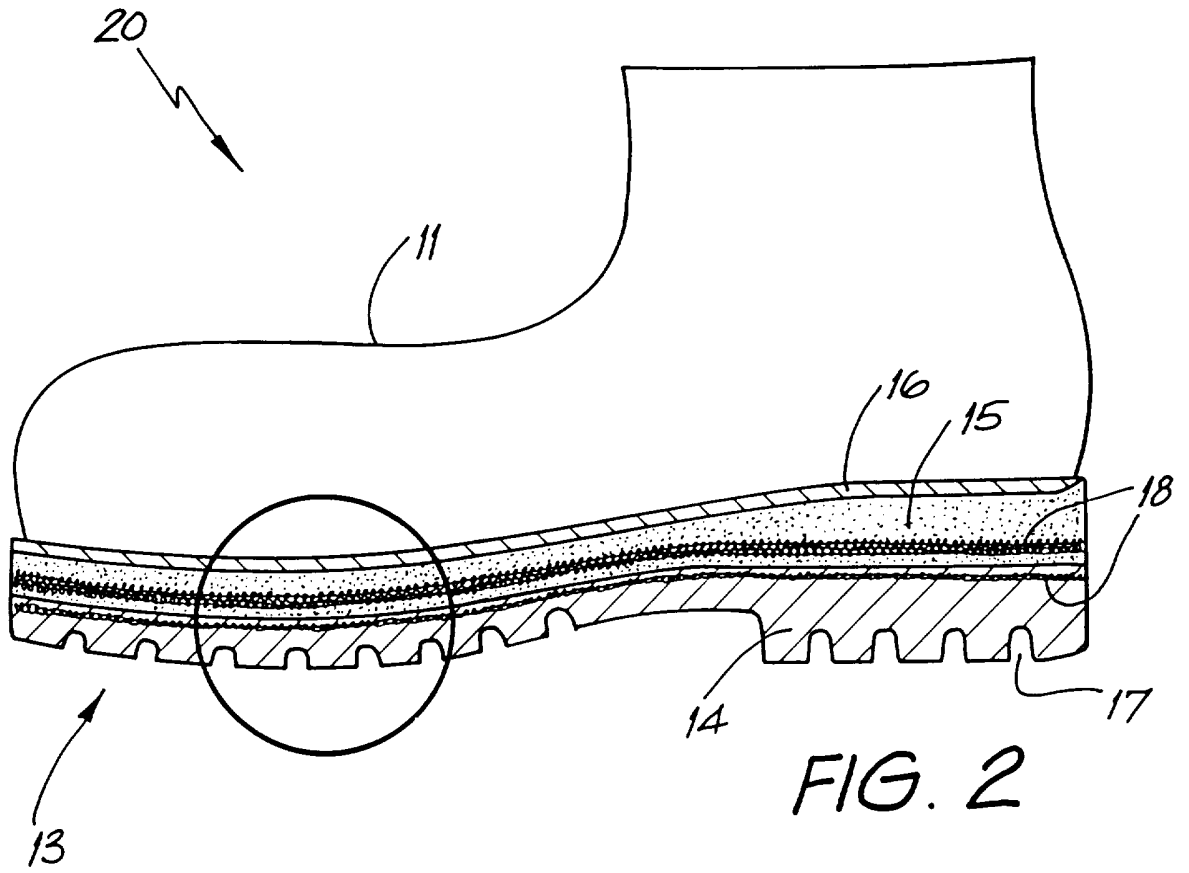

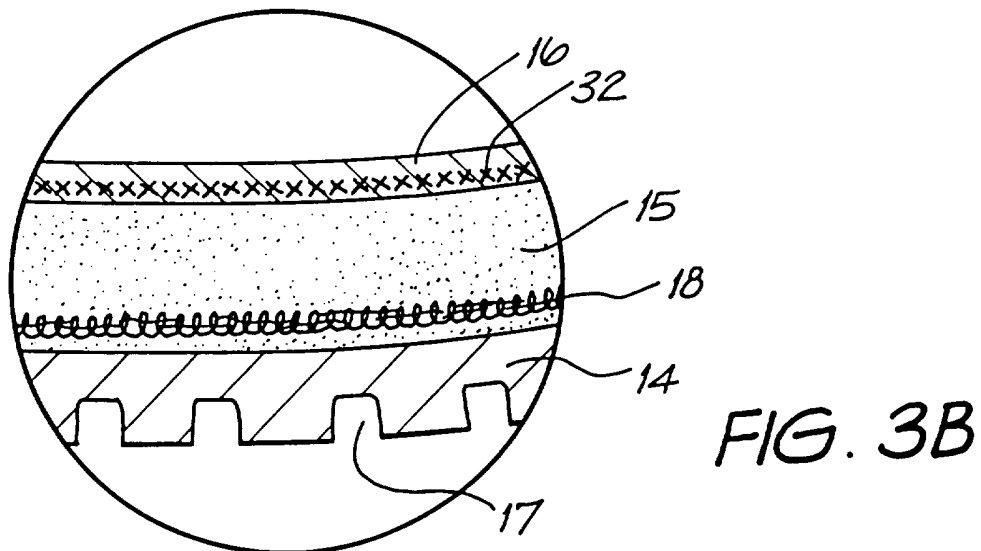
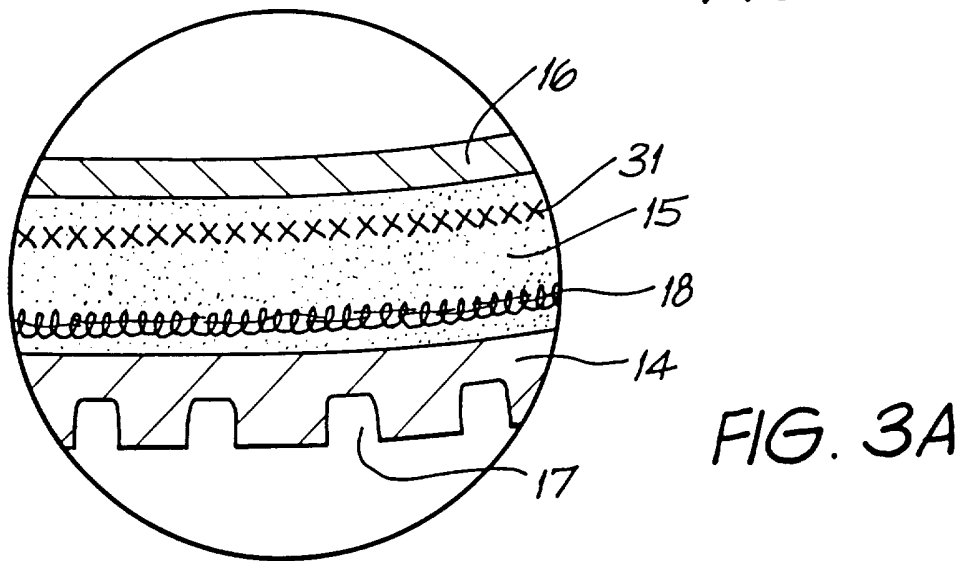
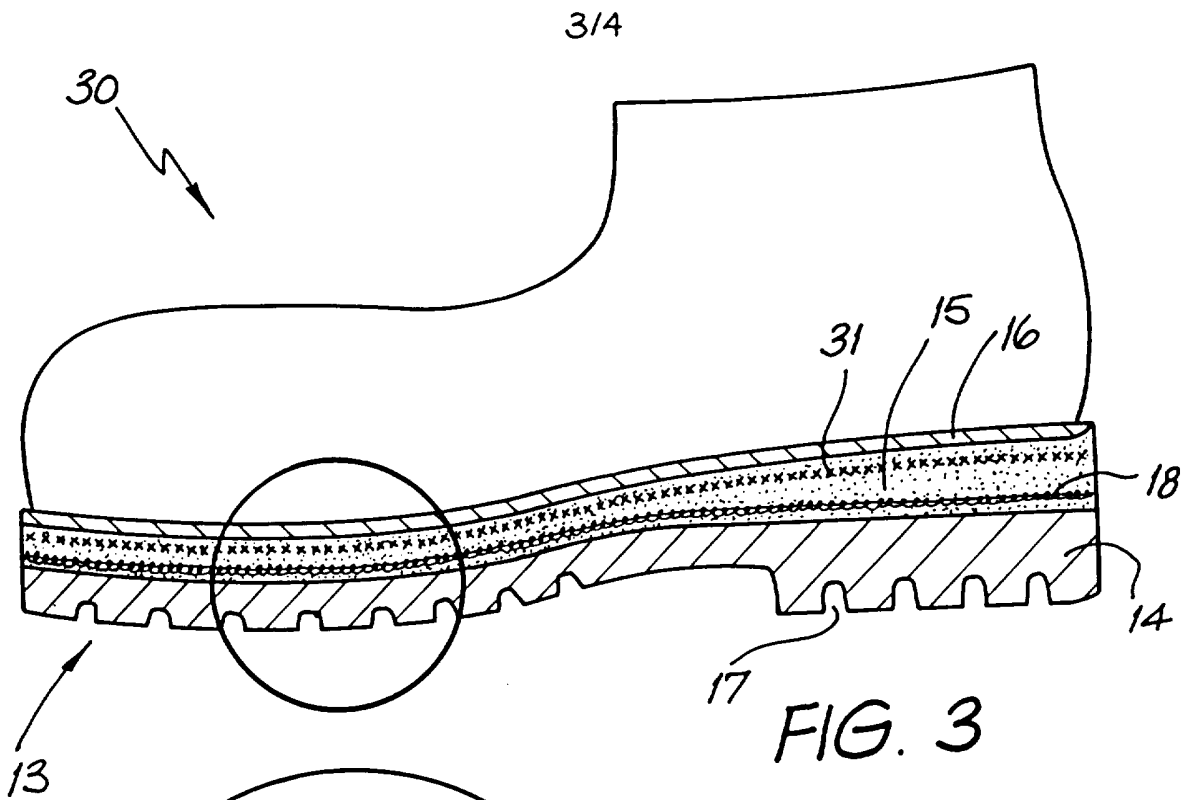

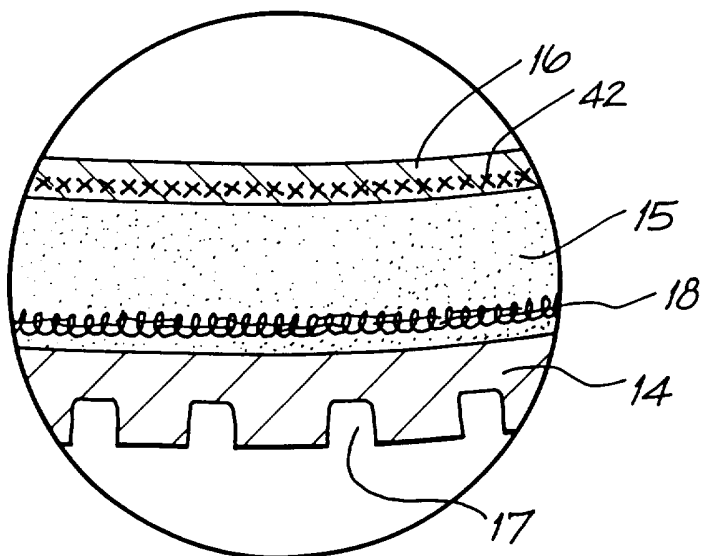
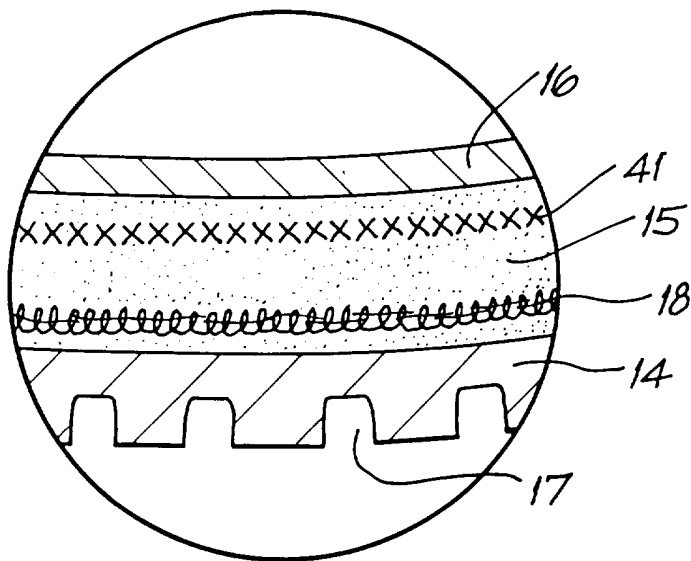
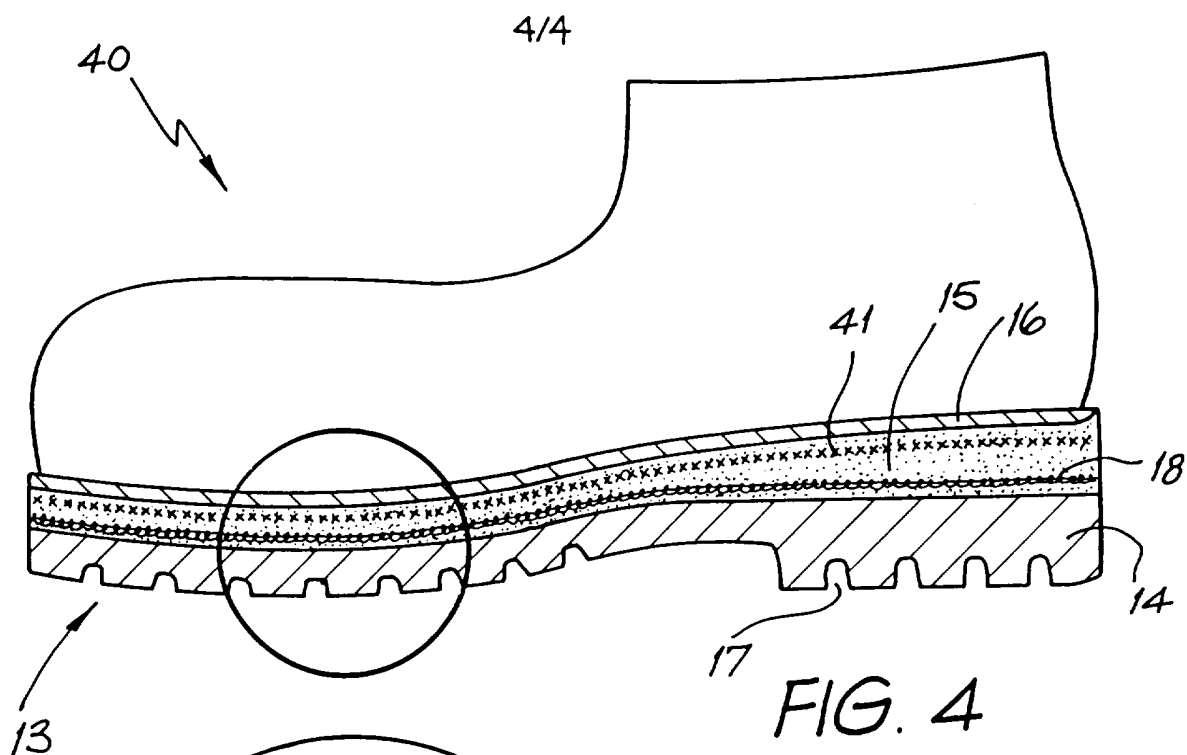

INTERNATIONAL SEARCH REPORT

International application No.

PCT/SG 96/00001

A. CLASSIFICATION OF SUBJECT MATTER

IPC<sup>6</sup>: A 43 B 7/32; A 43 B 13/12

According to International Patent Classification (IPC) or to both national classification and IPC

B. FIELDS SEARCHED

Minimum documentation searched (classification system followed by classification symbols)

IPC<sup>6</sup>: A 43 B

Documentation searched other than minimum documentation to the extent that such documents are included in the fields searched

Electronic data base consulted during the international search (name of data base and, where practicable, search terms used)

WPIL; EPODOC

C. DOCUMENTS CONSIDERED TO BE RELEVANT

Category*	Citation of document, with indication, where appropriate, of the relevant passages	Relevant to claim No.
X	US 4 858 338 A (SCHMID) 22 August 1989 (22.08.89), totality.	1-11
X	DE 22 16 439 A (FUNCK) 18 October 1973 (18.10.73), totality.	1
A	DE 30 27 601 A1 (FUNCK) 11 February 1982 (11.02.82), totality.	1-11
A	DE 33 21 889 A1 (SWENCO) 22 December 1983 (22.12.83), totality.	1-11
	----	

Further documents are listed in the continuation of Box C.

See patent family annex.

\* Special categories of cited documents:

- "A" document defining the general state of the art which is not considered to be of particular relevance
- "E" earlier document but published on or after the international filing date
- "L" document which may throw doubts on priority claim(s) or which is cited to establish the publication date of another citation or other special reason (as specified)
- "O" document referring to an oral disclosure, use, exhibition or other means
- "P" document published prior to the international filing date but later than the priority date claimed

- "T" later document published after the international filing date or priority date and not in conflict with the application but cited to understand the principle or theory underlying the invention
- "X" document of particular relevance; the claimed invention cannot be considered novel or cannot be considered to involve an inventive step when the document is taken alone
- "Y" document of particular relevance; the claimed invention cannot be considered to involve an inventive step when the document is combined with one or more other such documents, such combination being obvious to a person skilled in the art
- "&" document member of the same patent family

Date of the actual completion of the international search

18 June 1996 (18.06.96)

Date of mailing of the international search report

26 June 1996 (26.06.96)

Name and mailing address of the ISA/ AT  
 AUSTRIAN PATENT OFFICE  
 Kohlmarkt 8-10  
 A-1014 Vienna  
 Facsimile No. 1/53424/535

Authorized officer

Losenicky

Telephone No. 1/53424/384

**INTERNATIONAL SEARCH REPORT**  
Information on patent family members

International application No.

PCT/SG 96/00001

Im Recherchenbericht angeführtes Patentedokument Patent document cited in search report Document de brevet cité dans le rapport de recherche	Datum der Veröffentlichung Publication date Date de publication	Mitglied(er) der Patentfamilie Patent family member(s) Membre(s) de la famille de brevets	Datum der Veröffentlichung Publication date Date de publication
US A 4858338	22-08-89	keine - none - rien	
DE A 2216439		DE A1 2216439 DE B3 2216439 DE C2 2216439 FR A5 2179458 US A 3852895	18-10-73 22-05-75 08-01-76 15-11-73 10-12-74
DE A1 3027301	04-03-82	keine - none - rien	
DE A1 3321889	22-12-83	CA A1 1180891 FR A1 2528673 GB A0 2316249 GB A1 2121671	15-01-85 23-12-83 20-07-84 04-01-84