

T. WIARD.

Plow.

No. 22,332.

Patented Dec. 14, 1858.

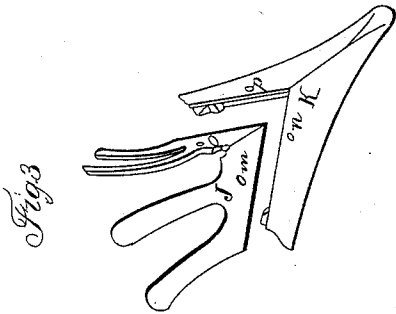

Fig. 2

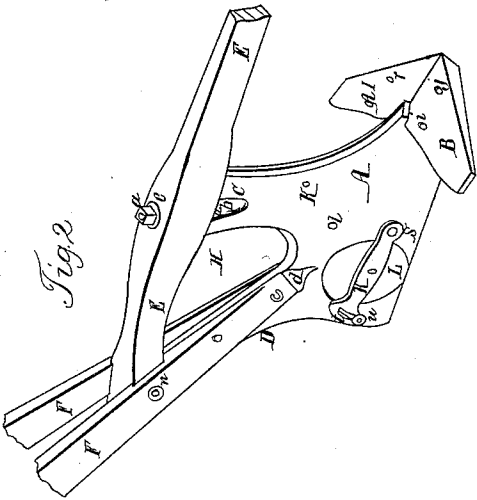

Fig. 5

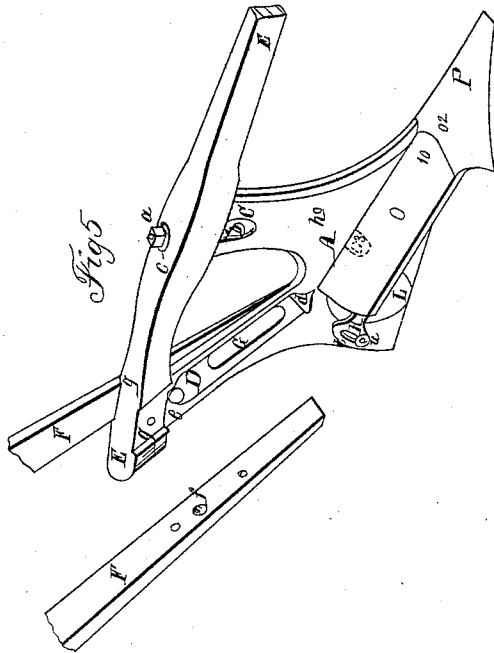

Fig. 1

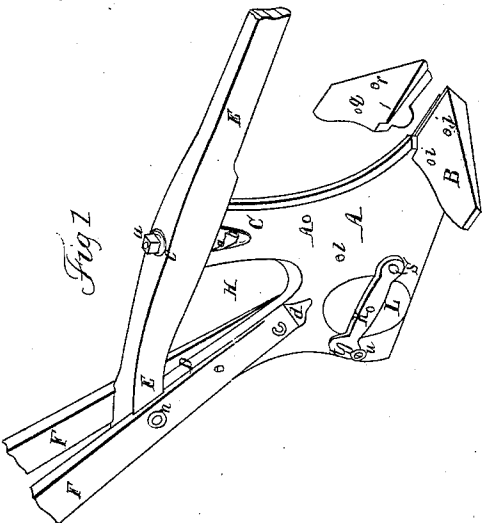
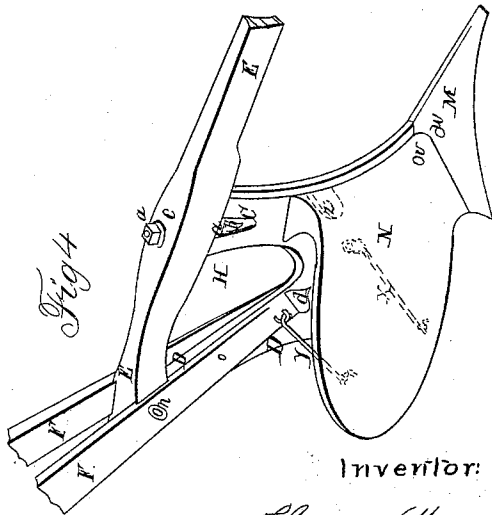

Fig. 4



Witnesses:

Daniell McGill
D Hewitt

Inventor:

Thos Wiard

UNITED STATES PATENT OFFICE.

THOS. WIARD, OF LOUISVILLE, KENTUCKY, ASSIGNOR TO G. W. PITKEN, H. W. PITKEN, AND W. L. P. WIARD, OF SAME PLACE.

IMPROVEMENT IN PLOWS.

Specification forming part of Letters Patent No. 22,332, dated December 14, 1858.

To all whom it may concern:

Be it known that I, THOMAS WIARD, of the city of Louisville, in the county of Jefferson and State of Kentucky, have invented certain new and useful Improvements in Combination-Plows; and I do hereby declare the following to be a full, clear, and exact description of the construction and operation of the same, reference being had to the accompanying drawings, making a part of this specification, in which—

Figure 1 represents the standard and wings of the plow as constructed to receive such a mold-board and point as may be desired to be used for a special purpose. Fig. 2 represents the wings as in place on the beam. Fig. 3 represents a point and ribbed mold-board in the position (though slightly separated) in which they are placed over the wings and against the standard to form a potato-plow. Fig. 4 represents the same beam and wings as used in connection with a common furrow-plow. Fig. 5 represents the plow as arranged for a sub-soiler, one of the handles being removed and turned over to show how they are braced to the beam.

Similar letters of reference, where they occur in the several figures, denote like parts of the plow in all of them.

I am aware that plows and cultivators have been so made as to be capable of a change of mold-boards. This I do not lay any claim to, my invention pertaining to the manner in which I construct the standard with one rigid and one removable wing, for the purpose of making said standard and wings susceptible of receiving the several changes of points and mold-board which are ordinarily used on a farm, thus making one stocked standard serve the purpose of holding the several varieties of plows used.

To enable others skilled in the art to make and use my invention, I will proceed to describe the same with reference to the drawings.

A represents the standard of the plow, which is cast with a permanent wing, B, on it. It has also two standards or uprights, C D, cast upon it, the one, C, for supporting the beam E by a screw-bolt, *a*, the head of which comes in an opening, *b*, left in the top of said standard, and its shank passing up through the beam E

and held by a nut, *c*. The other standard, D, thickens toward its top and supports the rear end of the stock E. The object in thickening the standard D is that the handles F F, which spread toward their tops, may lie snug against said standard. There are pockets *d* at the base of the standard D to receive the lower ends of the handles, and a button or stud, *e*, at its top, which enter a recess, *f*, in the handles. Gains *g g* are cut in the stock E in the line of the standard D, into which the plow-handles enter, so that a single bolt, *h*, passing through the handles and beam will not only rigidly unite these two pieces, but also hold them to the standard D. The portion G of the standard D is cast open for the sake of the lightness, and the space H between the two standards is left for the same purpose. There is also on the land side of the beam a shoe, widest at its rear-most part, as is common in other plows. There are two holes, *i j*, for screws or screw-bolts on the wing B, and two holes, *k l*, on the standard for a similar purpose, which holes, with the screw-bolts, make the standard susceptible of the changes of parts, as will be hereinafter mentioned.

I is a detached wing, separate from the standard, but fits up against it opposite to the stationary, permanent wing B, as shown in Fig. 2, there being a suitable recess and shoulder in that part of the standard to receive it. This removable wing is only used when a shovel or potato plow such as is shown at Fig. 3 is to be used. I mean any plow where the point or mold-board straddles, or is to be on both sides of the standard, for without such the wing I could not be held to the standard.

To make a potato-plow, the movable wing is laid into its position, as shown in Fig. 2. The open-ribbed mold-board J and the point K are slipped together, their shoulders, recesses, and lugs overlapping and interlocking with each other and screw-bolts passing through the holes *m n* in them and into those, *i j*, in the wing B, and other screw-bolts passing through the holes *o p* and into those, *q r*, of the removable wing I unite the whole permanently to the standard. Of course, any other shaped double point and mold-board may be similarly united to the standard.

It is proper here to state, in connection with the shovel or double-mold-board plow, that it requires additional means to guide it steadily, the user not being able to hold it steadily in its path by the handles. For this purpose I provide an arm, K, which is pivoted to the standard at *s*, and having a slot, *t*, in its other end, through which a set-screw, *u*, passes. In this arm K, or to it, is hung a disk or wheel, L, that can cut or penetrate into the ground, and thus prevent the rear of the plow from moving laterally. When the plow is used with a single mold-board or for turning an ordinary furrow, then this steering or steadying wheel is raised up, it not being necessary in such plowing; but for a shovel or potato plow it is indispensable.

When the plow is to be used for turning an ordinary furrow, as shown at Fig. 4, the removable parts just above described, as in Figs. 2, 3, are first taken off and the point M and mold-board N substituted for them, the same screw-bolts used in the former case passing through the holes *v w* in the said mold-board and point and into those, *i j*, of the fixed wing B. The mold-board may be further braced by the rods or links *xy*, as shown by dotted lines, Fig. 4. This forms a right-hand plow; but it is obvious that were the stationary wing placed on the left of the standard and the removable one fitted to the right side of it, left-hand plows could be made, if such were preferred. Further support may be also given to the mold-board N by a screw-bolt passing through the hole *k* in the standard into a lug, *z*, (in dotted lines, Fig. 4,) on the under side of said mold-board.

To convert the plow into a subsoiler I use the mold-board O and point P, as shown in Fig. 5, the screw-bolts passing through the holes 1 2 therein and into those, *i j*, in the wing B; and the mold-board O may be further secured by a bolt passing through the hole *l* in the standard and into a lug, *3*, (in dotted lines in Fig. 5,) on the under side of said mold-board.

It will thus be seen that the standard A and wing B, as shown and described, are common

to all the changes herein set forth, as is also the removable wing, for it must be present or it must be removed, as the circumstances of the case require. The invention is not therefore for the use of several varieties of plows used, but for a special part of the plow which is common to these several changes or substitutions, and so that one standard or body particularly constructed may receive and hold the several variable pieces that constitute, in whole or in part, the several varieties of plows.

The rear end of the beam E lies on top of the standard D (not being secured to it) by letting one into the other; but they are held together by the means which hold also the handles to the plow—viz., the dowels *e* on the standard D, and the recesses *f* on the handles, into which the dowels or studs *e* enter, and a single screw-bolt, *h*, passing through the handles and the rear of the beam. I thus make a very simple and effective junction or union of the handles, standard, and beam without uniting the standard and beam together, as is practiced by others.

Having thus fully described the nature and object of my invention, what I claim therein as new, and desire to secure by Letters Patent, is—

1. The standard A, with its permanent wing B, and recesses or shoulders for the reception of the removable wing I, constructed and arranged substantially in the manner and for the purpose set forth.

2. In combination with the standard A, constructed as herein set forth, the adjustable cutting and guiding wheel L, so that said wheel may be thrown into or out of action, as the circumstances of the case may require, and as described.

3. The uniting of the handles, beam, and standard together by means of the pockets *d*, dowels *e*, recesses *f*, and bolt *h*, substantially in the manner herein described.

THOS. WIARD.

Witnesses:

A. B. STOUGHTON,
E. COHEN.