



(19) **United States**

(12) **Patent Application Publication**
Montgomery

(10) **Pub. No.: US 2025/0024890 A1**

(43) **Pub. Date: Jan. 23, 2025**

(54) **AEROSOL GENERATION DEVICE**

(52) **U.S. Cl.**

(71) Applicant: **JT International SA**, Geneva (CH)

CPC *A24F 40/53* (2020.01); *A24F 40/51* (2020.01)

(72) Inventor: **Gordon Montgomery**, Ballymena, Co. Antrim Antrim (GB)

(73) Assignee: **JT International SA**, Geneva (CH)

(57) **ABSTRACT**

(21) Appl. No.: **18/684,060**

An aerosol generation device has a heating arrangement for heating an aerosol substrate, an electrical power source, a first switching element for controlling a supply of electrical power from the electrical power source to the heating arrangement, and a second switching element for decoupling the heating arrangement from the electrical power source. A method includes detecting a fault in the device by: controlling, during a first time period, one of the first and second switching elements to be on and other one of the first and second switching elements to be off, and determining whether an observable event occurs during the first time period, the observable event indicating that an amount of power is transferred to the heating arrangement. A fault is detected in other one of the first and second switching element elements if the at least one observable event is determined to occur during the first time period.

(22) PCT Filed: **Aug. 25, 2022**

(86) PCT No.: **PCT/EP2022/073668**

§ 371 (c)(1),

(2) Date: **Feb. 15, 2024**

(30) **Foreign Application Priority Data**

Aug. 31, 2021 (EP) 21194064.8

Publication Classification

(51) **Int. Cl.**

A24F 40/53 (2006.01)

A24F 40/51 (2006.01)

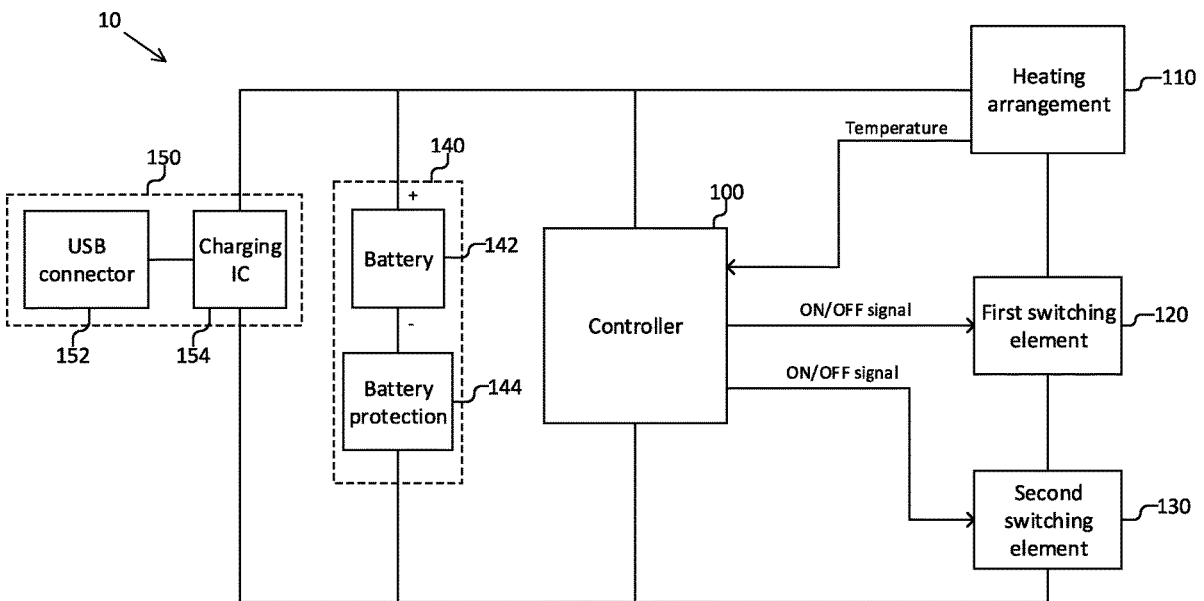

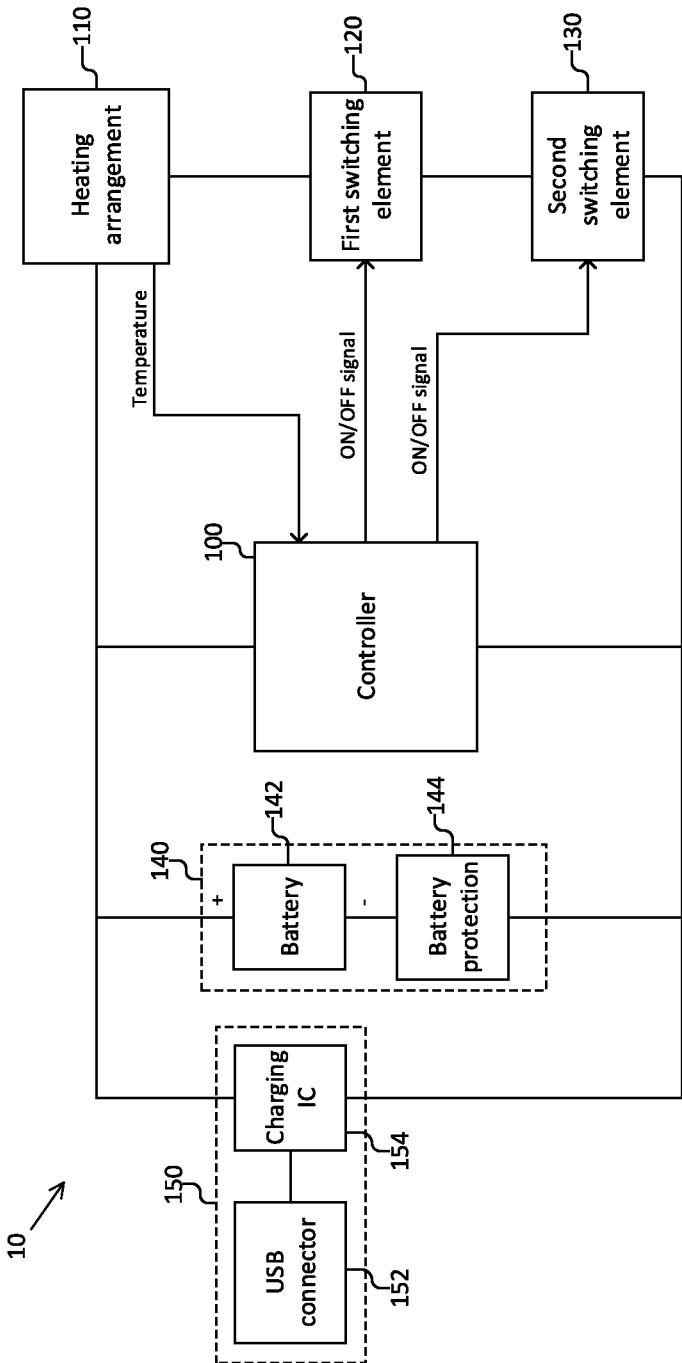

Fig. 1

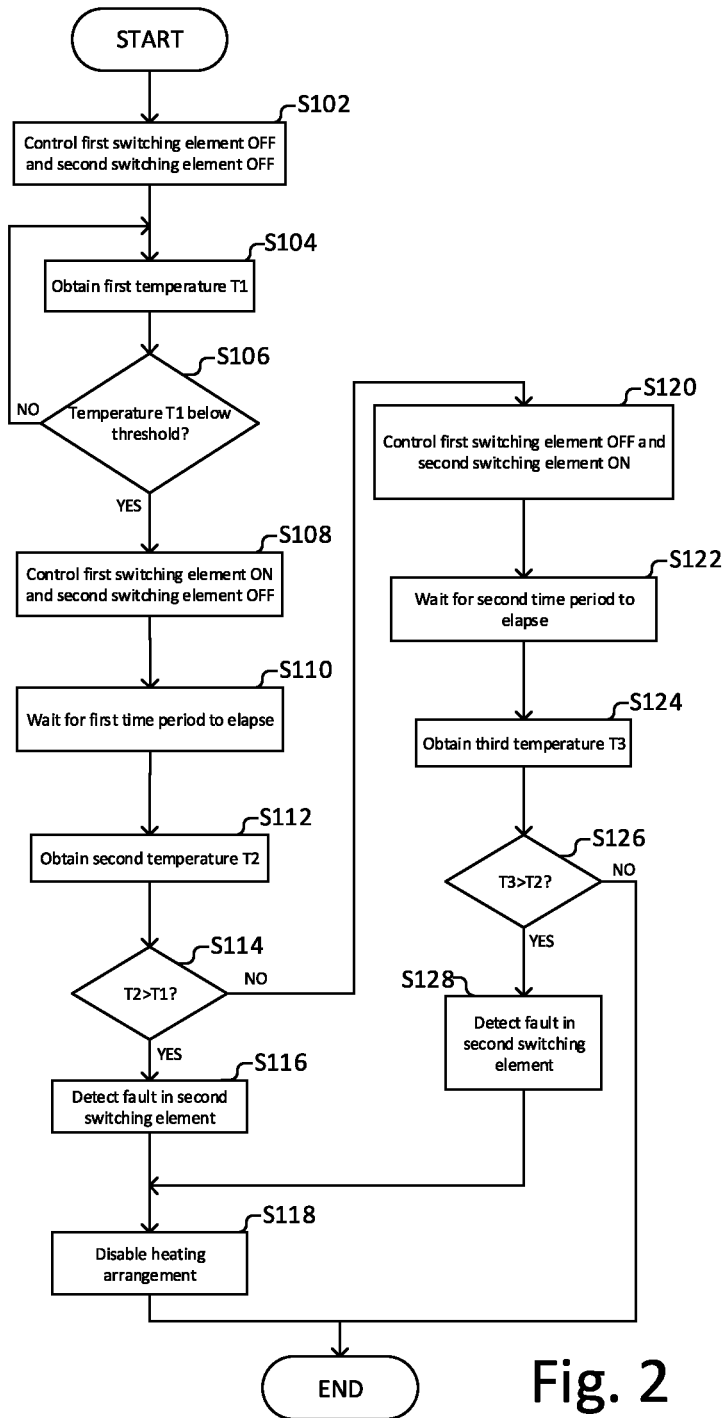

Fig. 2

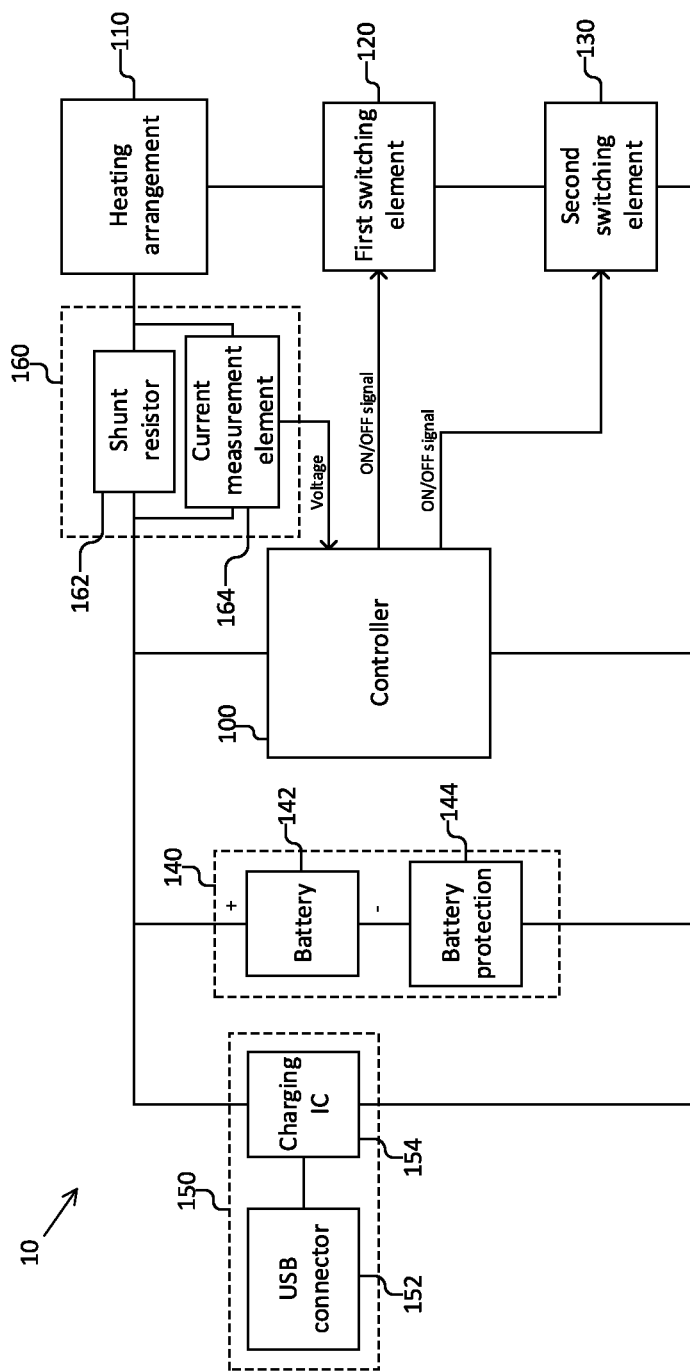

Fig. 3

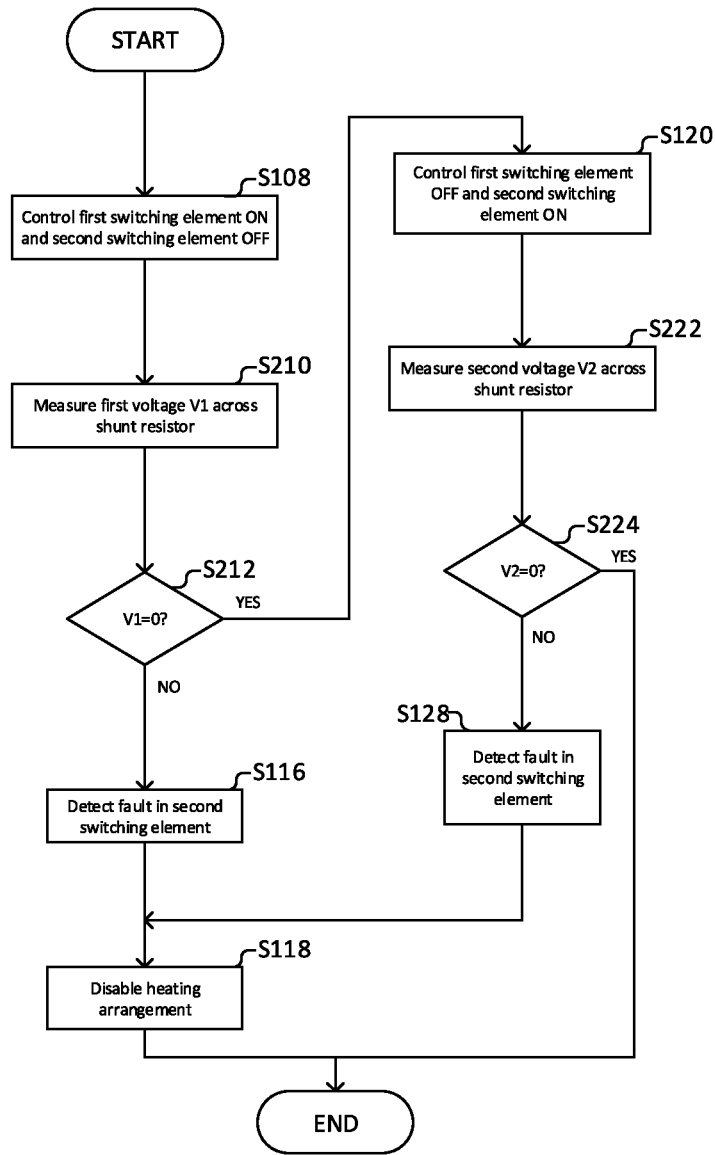

Fig. 4

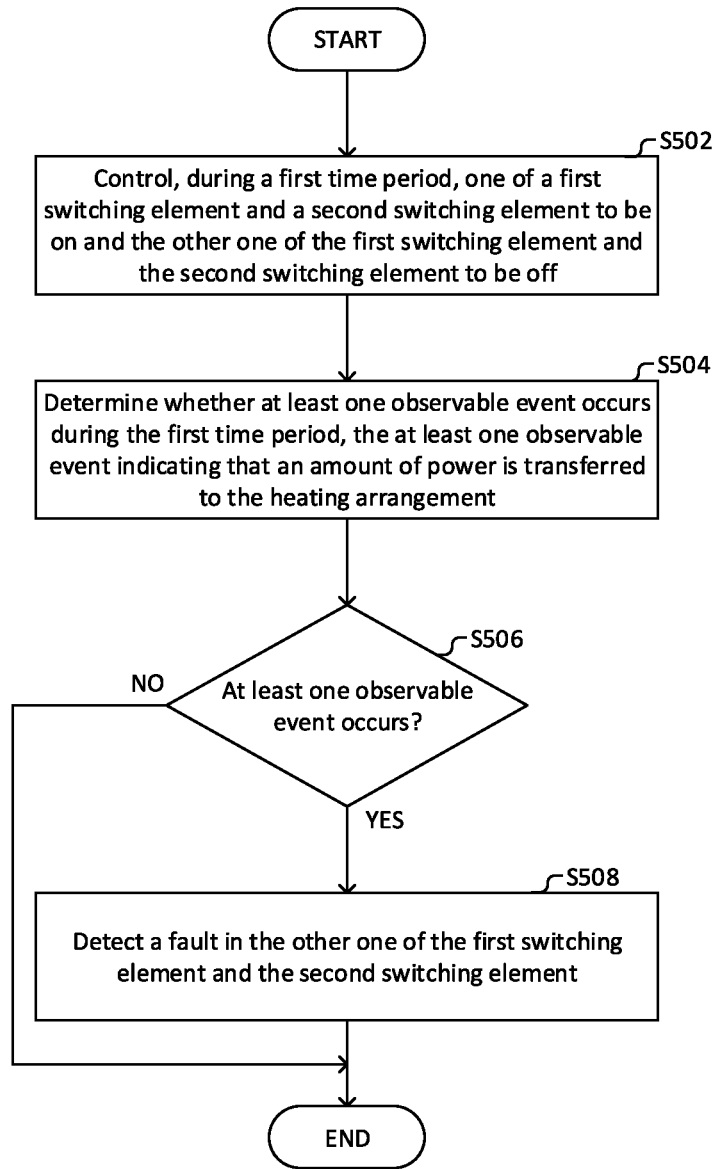

Fig. 5

AEROSOL GENERATION DEVICE

TECHNICAL FIELD

[0001] Example aspects herein relate to aerosol generation from a consumable, and in particular to a method for an aerosol generation device, a computer program, a controller for an aerosol generation device and an aerosol generation device.

BACKGROUND

[0002] There are known devices used to heat or warm aerosolisable substances, in order to generate an aerosol. For example, aerosol generation devices, with known types such as atomizers, vaporizers, electronic cigarettes, e-cigarettes, cigalikes, etc. are used to heat aerosolisable substances as a reduced-risk or modified-risk device from conventional tobacco products.

[0003] A commonly available reduced-risk or modified-risk device is the heated substrate aerosol generation device or heat-not-burn device. Devices of this type generate an aerosol or vapor by heating an aerosol substrate that typically comprises moist leaf tobacco or other suitable aerosolisable material. Heating an aerosol substrate, but not combusting or burning it, releases an aerosol that comprises the components sought by the user but not the toxic and carcinogenic by-products of combustion and burning.

[0004] Typically, the aerosolisable substance is provided in an aerosol substrate which is included in consumable, and when the consumable is coupled to the device, the device can heat or warm the substrate to generate the aerosol.

SUMMARY OF THE DISCLOSURE

[0005] In the aerosol generation device, electrical power is supplied from an electrical power source to a heating arrangement in the aerosol generation device, to heat the aerosolisable substance. The aerosol generation device controls the supply of electrical power using a first switching element arranged in series with the heating arrangement, between terminals of the electrical power source.

[0006] However, switching elements may fail, which may cause the heating arrangement to heat uncontrollably. To improve safety, a second switching element is arranged in series with the first switching element and the heating arrangement between the terminals of the electrical power source. Accordingly, the second switching element may be used to decouple the heating arrangement from the electrical power source and interrupt the supply of electrical power, if a fault prevents the first switching element from interrupting the electrical current from flowing (e.g. if the first switching element fail in a shorted state).

[0007] During normal use of the aerosol generation device, the second switching element is controlled to allow the supply of electrical power. Accordingly, if a fault prevents the second switching element from being controlled to interrupt the supply of electrical power (e.g. it fails in a shorted state), the safety of the aerosol generation device may be compromised, which increases risk of damage to the aerosol generation device and/or injury to a user of the aerosol generation device. In addition, such fault may not be detected as it would not prevent the aerosol generation device from heating the aerosolisable substance.

[0008] There is therefore a need to detect whether a fault occurs in the aerosol generation device, and in particular in one of the switching elements to improve safety.

[0009] According to a first example aspect disclosed herein, there is provided a method for an aerosol generation device, wherein the device comprises a heating arrangement for heating an aerosol substrate, an electrical power source, a first switching element for controlling a supply of electrical power from the electrical power source to the heating arrangement, and a second switching element for decoupling the heating arrangement from the electrical power source, wherein the heating arrangement, the first switching element and the second switching element are arranged in series between terminals of the electrical power source, the method comprising detecting a fault in the device by: controlling, during a first time period, one of the first switching element and the second switching element to be on and the other one of the first switching element and the second switching element to be off, and determining whether at least one observable event occurs during the first time period, the at least one observable event indicating that an amount of power is transferred to the heating arrangement, wherein a fault is detected in the other one of the first switching element and the second switching element if the at least one observable event is determined to occur during the first time period.

[0010] Accordingly, it is possible to detect whether a fault occurs in one of the switching elements, thus avoiding deterioration in the control of electrical power supply to the heating arrangement.

[0011] Preferably, the detecting comprises: controlling, during a second time period different from the first time period, the one of the first switching element and the second switching element to be off and the other one of the first switching element and the second switching element to be on, and determining whether the at least one observable event occurs during the second time period. In this case, a fault is detected in the one of the first switching element and the second switching element if the at least one observable event is determined to occur during the second time period.

[0012] Accordingly, it is possible to detect whether a fault occurs in either one of the switching elements.

[0013] Preferably, the method comprises disabling the heating arrangement upon detecting a fault.

[0014] Preferably, the at least one observable event comprises an increase of a temperature of the heating arrangement.

[0015] Preferably, the method comprises measuring, prior to the first time period, the temperature of the heating arrangement, and performing the detecting if the measured temperature is below a predetermined threshold.

[0016] Accordingly, the at least one observable indicating that an amount of power is transferred to the heating arrangement may be more readily detected.

[0017] Preferably, the at least one observable event comprises detecting an electrical current flowing from the electrical power source to the heating arrangement.

[0018] Preferably, the method is performed upon detecting that the device is coupled to an electrical power supply.

[0019] Preferably, the method is performed upon detecting a start of a use of the device.

[0020] According to a second example aspect disclosed herein, there is provided a computer program comprising instructions which, when executed by at least one processor,

cause the at least one processor to execute the method according to the first example aspect above.

[0021] According to a third example aspect disclosed herein, there is provided a controller for an aerosol generation device arranged to perform, when in use, the method according to the first example aspect above.

[0022] According to a fourth example aspect disclosed herein, there is provided an aerosol generation device comprising the controller according to the third example aspect, a heating arrangement for heating an aerosol substrate, an electrical power source, a first switching element for controlling a supply of electrical power from the electrical power source to the heating arrangement, and a second switching element for decoupling the heating arrangement from the electrical power source, wherein the heating arrangement, the first switching element and the second switching element are arranged in series between terminals of the electrical power source.

BRIEF DESCRIPTION OF THE DRAWINGS

[0023] Embodiments of the present invention, which are presented for better understanding the inventive concepts, but which are not to be seen as limiting the invention, will now be described with reference to the figures in which:

[0024] FIG. 1 is a block diagram showing an example of electrical components of an aerosol generation device according to an example embodiment;

[0025] FIG. 2 shows an example of a method for an aerosol generation device according to the example embodiment;

[0026] FIG. 3 is a block diagram showing an example of electrical components of an aerosol generation device according to a second example embodiment;

[0027] FIG. 4 shows an example of a method for an aerosol generation device according to the second example embodiment;

[0028] FIG. 5 shows an example of a method for an aerosol generation device according to example embodiments.

DETAILED DESCRIPTION

[0029] Although example embodiments will be described below, it will be evident that various modifications may be made to these example embodiments without departing from the broader spirit and scope of the invention. Accordingly, the following description and the accompanying drawings are to be regarded as illustrative rather than restrictive.

[0030] In the following description and in the accompanying figures, numerous details are set forth in order to provide an understanding of various example embodiments. However, it will be evident to those skilled in the art that embodiments may be practiced without these details.

[0031] FIG. 1 is a schematic diagram of electrical components of an aerosol generation device 10 according to an example embodiment.

[0032] In the example shown on FIG. 1, the aerosol generation device 10 comprises a controller 100, a heating arrangement 110, a first switching element 120, a second switching element 130, an electrical power source 140, and a charging arrangement 150.

[0033] As will be explained in more detail below, the controller 100 is arranged for controlling a state of the first

switching element 120 and a state of the second switching element 130, to control the supply of electrical power to the heating arrangement 110.

[0034] The electrical power source 140 is arranged for supplying electrical power to other components of the aerosol generation device 10, including the controller 100 and the heating arrangement 110.

[0035] In the example shown on FIG. 1, the electrical power source 140 comprises a battery 142 (e.g. a secondary battery such as a lithium-ion, nickel-metal hybrid or a non-rechargeable battery) and a battery protection circuit 144. However, it would be understood that the battery protection circuit 144 may be omitted in some cases (for example with batteries not requiring a protection circuit), or the electrical power source 140 may instead be a connector couplable to an electrical power source external to the aerosol generation device 10 (e.g. a mains electricity power, a DC 5V electrical power source etc.), and which transfers the electrical power from the external source to the components of the aerosol generation device 10.

[0036] The charging arrangement 150 is for supplying electrical power to re-charge the battery 142, from an electrical power source that is electrically coupled to the aerosol generation device. However, it would be understood that, in cases where the electrical power source 140 does not include a rechargeable element (e.g. the battery 142 is not rechargeable or is omitted), the charging arrangement 150 may be omitted as well.

[0037] In the example shown on FIG. 1, the charging arrangement 150 comprises a connector 152 couplable to an external electrical power source and a charging IC 154 for controlling the supply of power from the external electrical power source to the battery 142, optionally comprising a transformer for transforming the voltage/current characteristics of the electrical power supplied by the external power source.

[0038] The heating arrangement 110 is arranged for receiving a consumable and for heating the consumable to generate an aerosol using electrical power supplied from the electrical power source 140. The consumable may be any consumable including an aerosolisable substance (e.g. in an aerosol substrate) to generate an aerosol when heated, as the present invention is not limited in this aspect. By way of non-limiting examples, the consumable may be designed for a single use (i.e. that should only be heated once to generate aerosol substrate) or multiple use, the consumable may have various form, design, shape, packaging, type, flavor, etc.

[0039] In some examples, the consumable may include an aerosol substrate comprising the aerosolisable substance. It would be understood by the skilled person that the aerosol substrate may be any aerosol substrate for generating an aerosol, as the present invention is not limited in this aspect. By way of non-limiting examples, the aerosol substrate may be provided in various kind as a solid or paste type material in shredded, pelletized, powdered, granulated, strip or sheet form, optionally a combination of these. Equally, the aerosol substrate may include a fluid (e.g. liquid or gel). The aerosol substrate may include tobacco, for example in dried or cured form, in some cases with additional ingredients for flavoring or producing a smoother or otherwise more pleasurable experience. Depending on the materials included in the aerosol substrate, the consumable may be defined as a tobacco stick, or the aerosol substrate may be defined as a flavor release medium. In some examples, the aerosol sub-

strate such as tobacco may be treated with a vaporizing agent. The vaporizing agent may improve the generation of vapor from the aerosol substrate. The vaporizing agent may include, for example, a polyol such as glycerol, or a glycol such as propylene glycol. In some cases, the aerosol substrate may contain no tobacco, or even no nicotine, but instead may contain naturally or artificially derived ingredients for flavoring, volatilization, improving smoothness, and/or providing other pleasurable effects. The aerosol substrate such as tobacco may comprise one or more humectants to retain moisture, such as glycol(s).

[0040] The heating arrangement **110** comprises a heater for converting the electrical power received from the electrical power source into thermal energy to heat the consumable, and a temperature sensor for sensing a temperature of the heating arrangement **110**. The heater may be any type of heater, such as conduction-based or convection-based heaters (e.g. a coil, a coil-and-wick combination), as the present invention is not limited to specific kind of heaters. The temperature sensed by the temperature sensor is obtained by the controller **100**, as shown by the arrow on FIG. 1.

[0041] In some examples, the heating arrangement **110** may comprise additional elements, such as a converter (e.g. a booster circuit) for converting the electrical power received from the electrical power source **140** into an electrical power suitable to heat the aerosol substrate.

[0042] The first switching element **120** and the second switching element **130** are arranged in series with the heating arrangement **110**, between terminals of the electrical power source **140**. The heating arrangement **110**, the first switching element **120** and the second switching element **130** are considered to be in series between terminals of the electrical power source **140** as they form part of the same electrical current loop. The electrical current loop may, in some cases, include other elements, such as the battery protection circuit **144** as shown on FIG. 1.

[0043] In the example shown on FIG. 1, the first switching element **120** and the second switching element **130** are MOSFETs.

[0044] The first switching element **120** and the second switching element **130** may each be a transistor, such as Field-effect transistors (FET) (e.g. Si MOSFETs, GaN MOSFETs, SiC MOSFETs, etc.), a Bipolar Junction Transistor (BJT), insulated-gate bipolar transistor (IGBT), thyristors, or other known types of switching element. The first switching element **120** and the second switching element **130** may be of the same type, or they may be of different types of switching elements.

[0045] Although FIG. 1 shows the heating arrangement **110**, the first switching element **120** and the second switching element **130** to be arranged in this order, between the terminals of the electrical power source, the order shown on FIG. 1 is merely exemplary, and may be varied. For example, the heating arrangement **110** may be placed between the first switching element **120** and the second switching element **130**, both the first switching element **120** and the second switching element **130** may be placed before (i.e. closer to the terminal of the electrical power source labelled +) the heating arrangement **110**, the second switching element **130** may be placed before the first switching element **120**, etc.

[0046] The controller **100** may comprise one or more processor (e.g. a single/multiple core CPU, microprocessor (s) etc.), one or more working memories (e.g. random-access

memory, RAM, flash memory etc.) and one or more non-volatile instructions stores (e.g. read-only memory (ROM), programmable ROM (PROM), erasable PROM (EPROM), electrically erasable PROM (EEPROM), flash memory, etc.) storing computer-readable instructions, whereby the processor(s) executing the computer-readable instructions in the instruction store(s) to control the state of the first switching element **120** and the second switching element **130**. In other examples, the controller may be implemented, in part or in full, as hardware components such as integrated circuitry (IC).

[0047] Accordingly, it would be understood that the controller **100** may include one or more units or modules to perform various operations.

[0048] In an example, the controller **100** may include a microcontroller, MCU, and a separate hardware monitoring circuit. In this example, the MCU is arranged for controlling the state of the first switching element **120** and the second switching element **130** to control the temperature of the heating arrangement **110**, and the hardware monitoring circuit is arranged for disabling the first switching element **120** and/or the second switching element **130** if a fault is detected in the aerosol generation device **10**.

[0049] In the example shown on FIG. 1, the controller **100** is a microcontroller, MCU.

[0050] As stated above, the controller **100** is arranged for controlling the state of the first switching element **120** and the state of the second switching element **130**, to control the supply of electrical power to the heating arrangement **110**. Specifically, the controller **100** (or a signal generator included in or controlled by the controller **100**) generates a control signal to cause the first switching element **120** to be ON or OFF, as shown by the arrow on FIG. 1. In the present disclosure, a switching element is considered to be ON when electrical current is allowed to flow through the switching element, and a switching element is considered to be OFF when the electrical current is prevented from flowing through the switching element. Similarly, the controller **100** generates a control signal to cause the second switching element to be ON or OFF, as shown by the arrow on FIG. 1.

[0051] In the example of FIG. 1, the control signals generated by the controller **100** are applied to the gate of the first switching element **120** and the gate of the second switching element **130**.

[0052] If either the first switching element **120** or the second switching element **130** is OFF (or both), the electrical current loop is interrupted, and no electrical current can flow through the heating arrangement **110**. Therefore, the controller **100** can control whether the heating arrangement **110** is supplied with electrical power, by controlling the state of the first switching element **120** and the second switching element **130**.

[0053] A user desiring that an aerosol to be generated from the consumable can initiate the heating of the consumable to obtain the aerosol, for example by operating/manipulating the aerosol generation device or e.g. a button/switch provided on the aerosol generation device. This indicates the beginning of an aerosol generation session. The controller **100** thus controls the temperature of the heating arrangement **110** to a desired temperature at which the aerosolizable substance generates the aerosol (e.g. by evaporation, subli-

mation etc.). By way of non-limiting example, the desired temperature may be a temperature in the range of 200-250° C.

[0054] In the example of FIG. 1, the controller 100 generates a control signal to maintain the second switching element 130 in an ON state, thereby enabling electrical power to be supplied to the heating arrangement 110. The controller 100 obtains a sensed temperature of the heating arrangement 110 from the temperature sensor. The controller 100 implements a control loop (e.g. a PID (Proportional, Integral, Derivative), PI or P control loop) using the sensed temperature and the desired temperature of the heating arrangement 110, to generate a pulse-width modulation, PWM, signal for controlling the state of the first switching element 120 and causing the heating arrangement 110 to reach (and be maintained at) the desired temperature.

[0055] For brevity, further details of the control loop and the control of the first switching element 120 that would be known to the skilled person are omitted. However, it should be understood that the controller is not limited to the use of a PID control loop and/or controlling the switching element with a PWM signal, and any other type of control loop or any other type of signal to control the switching element may be used instead.

[0056] When the controller 100 determines that the heating arrangement 110 should no longer be heated (e.g. at the end of an aerosol generation session such as when a user stops using aerosol generation device 10, the aerosolizable substance is depleted, etc.), the controller controls the first switching element 120 and the second switching element 130 to an OFF state, allowing the heating arrangement 110 to cool down.

[0057] A method for detecting a fault in the aerosol generation device according to an exemplary embodiment will now be described.

[0058] Referring now to FIG. 2, at step S102, the controller 100 generates control signals to cause the first switching element 120 to be OFF and the second switching element 130 to be OFF.

[0059] At step S104, the controller 100 obtains a first temperature value T1 of the heating arrangement 110 from the temperature sensor.

[0060] At step S106, the controller 100 determines whether the first temperature value T1 is equal to or lower than a predetermined threshold. The threshold may be set at a value which ensures that an increase in temperature may be detected over a certain time period (e.g. the first time period or the second time period described below). For example, the threshold may be set to be 50° C., or 100° C.

[0061] If the first temperature value T1 is not equal to or lower than the threshold (Step S106: NO), the controller 100 returns to step S104 to obtain the temperature value T1 anew. Optionally, the controller 100 may wait a predetermined amount of time before obtaining the temperature value T1 again, to let the temperature of the heating arrangement 110 decrease.

[0062] On the other hand, if the first temperature value T1 is equal to or lower than the threshold (Step S106: YES), the method proceeds to step S108.

[0063] Although the process of step S106 has been described for the example where the controller 100 determines whether the first temperature value T1 is equal to or lower than the threshold, the controller 100 may alterna-

tively be arranged to determine whether the first temperature value T1 is strictly lower (i.e. not equal to) the threshold.

[0064] At step S108, the controller 100 controls the first switching element 120 to be ON, and the second switching element 130 to be OFF during a first time period.

[0065] In case there is a fault causing the second switching element 130 to remain in an ON state or in a shorted state where the flow of electrical current through the switching element cannot be interrupted, electrical power will be supplied to the heating arrangement 110, and the temperature of the heating arrangement 110 will increase during the first time period.

[0066] In some cases, the length of the first time period may be set so as to allow an increase in temperature to be detected, which may depend on the measured first temperature value T1, the characteristics of the heating arrangement 110, the characteristics of the electrical power supplied by the electrical power supply, the temperature threshold, the characteristics of the temperature sensor, etc.

[0067] At step S110, the controller 100 waits for the first time period to elapse. For example, the controller 100 may trigger a timer equal to the first time period when controlling the first switching element 120 to be ON and the second switching element 130 to be OFF, and the controller 100 may wait for the timer to expire.

[0068] When the first time period has elapsed, the controller proceeds to step S112.

[0069] At step S112, the controller 100 obtains a second temperature value T2 of the heating arrangement 110 from the temperature sensor. The controller 100 then proceeds to step S114.

[0070] At step S114, the controller 100 determines whether the second temperature value T2 is higher than the first temperature value T1.

[0071] The second temperature value T2 being higher than the first temperature value T1 is an example of an observable event (an increase in temperature) that occurs during the first time period, and which indicates that an amount of electrical power is transferred to the heating arrangement 110.

[0072] In some cases, the controller 100 may be arranged to determine whether the second temperature value T2 is higher than the first temperature value T1 by at least a predetermined amount. For example, by at least 3° C. or by an amount corresponding to at least 5% of the value T1. Accordingly, the controller 100 may be less likely to incorrectly determine the second switching element 130 is ON or shorted, when the increase in temperature is due to other factors (e.g. environmental factors, inaccuracy in the temperature sensor, etc.).

[0073] If the controller 100 determines that the second temperature value T2 is higher than the first temperature value T1 (Step S114: YES), the controller 100 proceeds to step S116.

[0074] At step S116, the controller 100 detects a fault in the second switching element 130 which causes the second switching element to be ON or in a shorted state, and proceeds to step S118.

[0075] At step S118, the controller 100 disables the heating arrangement 110, and the process ends.

[0076] For example, the controller 100 may generate a signal to disconnect the heating arrangement 110 from the electrical power source 140, or the controller 100 may cause the heating arrangement 110 to be bypassed (e.g. by shunt

resistor in parallel with the heating arrangement 110) so that electrical power is not supplied to the heating arrangement 110.

[0077] In some cases, the controller 100 may also generate a notification to the user to indicate that a fault occurred in the aerosol generation device 10 and/or that the heating arrangement 110 is disabled. For example, in cases where the aerosol generation device 10 includes a display screen, the controller 100 may cause the display screen to display a message notifying the user of the aerosol generation device that the consumable does not have the required moisture content. However, it would be understood that other means of notifying the user, such as haptic feedback, other visual feedback (e.g. via a LED located on the aerosol generation device 10), audio feedback may be used instead or in addition to the display of the message.

[0078] If, at step S114, the controller 100 determines that the second temperature value T2 is not higher than the first temperature value T1 (Step S114: NO), the controller 100 proceeds to step S120.

[0079] At step S120, the controller 100 controls the first switching element 120 to be OFF, and the second switching element 130 to be ON during a second time period.

[0080] As explained in connection with step S108 above, if there is a fault causing the first switching element 120 to remain in an ON state or in a shorted state, the temperature of the heating arrangement 110 will increase during the second time period.

[0081] As with the first time period, the second time period may, in some cases, be set based on the second temperature value T2, the characteristics of the heating arrangement 110, the characteristics of the electrical power supplied by the electrical power supply, the temperature threshold, etc. The second time period may have the same length as the first time period, although this is not required.

[0082] After step S120, the controller 100 proceeds to step S122.

[0083] At step S122, the controller 100 waits for the second time period to elapse. The process at this step is the same as the process described in step S110 for the first time period. Then, the controller 100 proceeds to step S124.

[0084] At step S124, the controller 100 obtains a third temperature value T3 of the heating arrangement 110 from the temperature sensor, then proceeds to step S126.

[0085] At step S126, the controller 100 determines whether the third temperature value T3 is higher than the second temperature value T2.

[0086] As explained in connection with step S114, in some cases, the controller 100 may be arranged to determine whether the third temperature value T3 is higher than the second temperature value T2 by at least a predetermined amount (which may be the same as the predetermined amount in step S114 or a different predetermined amount).

[0087] In some cases, instead of comparing the second temperature value T2 and the third temperature value T3, the controller 100 may instead determine whether the third temperature value T3 is greater than the first temperature value T1, since it has been determined (in step S114) that the second temperature value T2 is equal to (or at least not greater than) the first temperature value T1.

[0088] If the controller 100 determines that the third temperature value T3 is higher than the second temperature value T2 (Step S126: YES), the controller 100 proceeds to step S128.

[0089] At step S128, the controller 100 determines that a temperature increase occurs during the second time period, which is an example of an observable event indicating that an amount of power is transferred to the heating arrangement 110. Accordingly, the controller 100 detects a fault in the first switching element 120 which causes the first switching element 120 to be ON or in a shorted state. The controller 100 then proceeds to step S118.

[0090] If, on the other hand, the controller 100 determines that the third temperature value T3 is not higher than the second temperature value T2 (Step S126: NO), the process ends as this indicates that no fault causing the first switching element 120 to be ON or in a shorted state is detected.

[0091] Accordingly, by performing the method of the exemplary embodiment, the controller 100 may detect whether a fault occurs in the first switching element 120 and/or in the second switching element 130.

[0092] An example of an aerosol generation device according to a second example embodiment will now be described.

[0093] FIG. 3 is a schematic diagram of electrical components of an aerosol generation device 10 according to the second example embodiment.

[0094] For brevity, description of the electrical components 110 to 150 will be omitted here as these have already been described in connection with FIG. 2.

[0095] In the example shown on FIG. 3, the aerosol generation device 10 includes a current measuring arrangement 160 for measuring an electrical current provided to the heating arrangement 110. The current measuring arrangement 160 comprises a shunt resistor 162 placed in series with the heating arrangement 110. The current measuring arrangement 160 also comprises a current measurement element 164 in parallel with the shunt resistor 162, the current measurement element 164 being arranged for detecting whether a current flows through the shunt resistor 162.

[0096] In the example shown on FIG. 3, the controller 10 is arranged for obtaining a value of the voltage measured across the shunt resistor 162 by the current measurement element 164. The controller 100 can therefore detect that an electrical current is flowing through the shunt resistor 162 if a non-zero voltage is measured across the shunt resistor 162.

[0097] As the shunt resistor 162 is in series with the heating arrangement 110, the controller 100 can determine that an amount of power is transferred to the heating arrangement if a current is detected to flow through the shunt resistor 162. Accordingly, a current flowing through the shunt resistor 162 is an example of an observable event indicating that an amount of power is transferred from the electrical power source 140 to the heating arrangement 110.

[0098] A method for detecting a fault in the aerosol generation device according to the second exemplary embodiment will now be described, with reference to FIG. 4.

[0099] For brevity, description of steps S108, S116, S118, S120 and S128 will be omitted here as these have already been described in connection with FIG. 2.

[0100] As shown on FIG. 4, steps S102 to S106 are omitted, and the process starts at step S108. The controller controls the first switching element 120 to be ON and the second switching element 130 to be OFF during a first time period.

[0101] In the second example embodiment, no increase in temperature needs to be detected, therefore the first time

period may be set shorter than in the first example embodiment. As a result, the method may be performed faster and/or using less energy.

[0102] After step S108, the controller proceeds to step S210, where the controller 100 obtains a first voltage value V1 across the shunt resistor 162. The controller 100 then proceeds to step S212.

[0103] At step S212, the controller 100 determines whether the first voltage value V1 is equal to zero.

[0104] If the controller 100 determines that the first voltage value V1 is not equal to zero (Step S212: NO), the controller 100 determines that a current is flowing through the shunt resistor 162 and thus electrical power is supplied to the heating arrangement 110. The controller thus proceeds to step S116 where it detects a fault in the second switching element 130 that causes the second switching element 130 to remain ON or shorted.

[0105] If on the other hand the controller 100 determines that the first voltage value V1 is equal to zero (Step S212: YES), the controller proceeds to step S120.

[0106] In some cases, the controller 100 may be arranged for determining whether the first voltage value V1 has a magnitude (or absolute value) greater than a predetermined voltage value. Accordingly, the controller 100 may be less likely to incorrectly detect a fault in the second switching element 130, if, for example, a non-zero voltage is inaccurately detected across the shunt resistor 162.

[0107] For example, the controller 100 may be arranged for determining whether the first voltage value V1 is greater than 0.3V (or lower than -0.3V), although this voltage value is provided purely as a non-limiting example.

[0108] At step S120, the controller 100 controls the first switching element 120 to be OFF and the second switching element 130 to be ON during a second time period. As with the first time period, the second time period may be set shorter in the second example embodiment than in the first example embodiment.

[0109] After step S120, the controller 100 proceeds to step S222, where the controller 100 obtains a second voltage value V2 across the shunt resistor 162.

[0110] At step S224, the controller 100 determines whether the second voltage value V2 is equal to zero.

[0111] As explained in connection with step S212, in some cases, the controller 100 may be arranged to determine whether the second voltage value V2 has a magnitude greater than a predetermined voltage value (which may be the same as the predetermined voltage value in step S212 or a different predetermined voltage value), thereby reducing risks of incorrect fault detection by the controller 100.

[0112] If the controller 100 determines that the second voltage value V2 is not equal to zero (S224: NO), the controller 100 proceeds to step S128, where the controller detects a fault in the first switching element 120.

[0113] If the controller 100 determines that the second voltage value V2 is equal to zero (S224: YES), the process ends as this indicates that no fault is detected in the first switching element 120.

[0114] It will be appreciated from the description above that certain example embodiments perform a method for an aerosol generation device comprising a heating arrangement for heating an aerosol substrate, an electrical power source, a first switching element for controlling a supply of electrical power from the electrical power source to the heating arrangement, and a second switching element for decoupling

the heating arrangement from the electrical power source, wherein the heating arrangement, the first switching element and the second switching element are arranged in series between terminals of the electrical power source.

[0115] Referring to FIG. 5, at step S502, the aerosol generation device controls, during a first time period, one of the first switching element and the second switching element to be on and the other one of the first switching element and the second switching element to be off.

[0116] At step S504, the aerosol generation device determines whether at least one observable event occurs during the first time period, the at least one observable event indicating that an amount of power is transferred to the heating arrangement.

[0117] If the at least one observable event is determined to occur during the first time period, at step S508, the aerosol generation device detects a fault in the other one of the first switching element and the second switching element.

[0118] Each of the methods described above with reference to FIG. 2, 4 or 5 may be performed at various timing(s), such as when a predetermined event occurs.

[0119] As a first example, each of the methods may be performed upon detecting that the aerosol generation device 10 is coupled to an external power supply (e.g. when the external power supply is coupled to the charging arrangement 150). Accordingly, based on the assumption that the aerosol generation device 10 is coupled to the external power supply when not used, the method may be performed whilst reducing any impact on the user.

[0120] As a second example, each of the methods may be performed upon detection that a consumable is inserted in the heating arrangement 110, or at the start of a use of the aerosol generation device (i.e. the beginning of an aerosol generation session), before the consumable is heated. In these cases, the method may reduce risks that the heating arrangement is heated when the aerosol generation device is unsafe (or less safe), therefore reducing risks of failure when element(s) of the device is/are hot, which may reduce risks of injury and/or damage.

[0121] As a third example, each of the methods may be performed at the end of a use/aerosol generation session, after the heating arrangement 110 is turned off to be cooled down. Accordingly, the method may allow the detection of a fault that results from the previous heating of the heating arrangement 110 in one or both of the switching elements. In addition, the predetermined event in the third example is less likely to delay the heating of the heating arrangement 110 and the consumable, and thus would lessen the effect on user-friendliness of the aerosol generation device 10.

Modifications and Variations

[0122] Many modifications and variations can be made to the example embodiments described above.

[0123] For example, some of the steps illustrated on FIG. 2 or 4 may be omitted.

[0124] Specifically, in cases where the method shown on FIG. 2 is performed when the temperature of the heating arrangement 110 is known to be below a threshold (e.g. if the method is performed when a consumable is inserted, the aerosol generation device is turned on, or the aerosol generation device has not been in use for at least a predetermined amount of time), steps S102 and S104 may be omitted.

[0125] In some cases, the first switching element 120 and/or the second switching element 130 may already be in a desired state, such that the term “control the switching element to be ON” or OFF would mean that the controller 100 causes that switching element to remain in that state.

[0126] In the description above, the first switching element 120 is controlled using a PWM signal, to regulate the temperature of the heating arrangement 110, and the second switching element 130 is maintained in an ON state to enable the supply of electrical power to the heating arrangement 110. However, it would be understood that the first switching element 120 and the second switching element 130 may be interchangeable, and the first switching element 120 may be maintained in an ON state whilst the second switching element 130 is controlled using a PWM signal to regulate the temperature of the heating arrangement 110.

[0127] The methods shown on FIGS. 2 and 4 both illustrate the examples where the first switching element 120 is ON during the first time period, and OFF during the second time period (and vice-versa for the second switching element 130). However, the opposite case is also possible, where the controller 100 controls the first switching element 120 to be OFF and the second switching element 130 to be ON during the first time period (meaning that a fault in the first switching element 120 would be detected in step S116), and the first switching element 120 to be ON and the second switching element 130 to be OFF during the second time period (meaning that a fault in the second switching element 130 would be detected in step S128).

[0128] The methods shown on FIGS. 2 and 4 both illustrate the examples where, if a fault is detected in either the first switching element 120 or the second switching element 130, the heating arrangement 110 is disabled in step S118. However, the controller 100 may instead be arranged to allow the use of a consumable and notify the user of the fault to prompt the user to repair or replace the aerosol generation device 10, if a fault is detected in one or both of the switching elements.

[0129] In the methods shown on FIGS. 2 and 4, detecting a fault in one of the switching elements (at step S116) causes the process to end without checking whether a fault occurs the other one of the switching elements. Alternatively, the controller 100 may be arranged to proceed, after step S116 or after step S118, with the steps checking the other one of the switching elements, i.e. steps S120 to S128 on FIG. 2, or steps S120, S222, S224 and S128 on FIG. 4.

[0130] Although a specific configuration of the aerosol generation device 10 with a current measuring arrangement 160 has been described above, it would be understood that the present invention is not limited to this specific arrangement, and different configurations of the current measuring arrangement 160 and/or different placement of the current measuring arrangement 160 in the circuit shown on FIG. 3 are possible. For example, the current measurement arrangement (with the same or a different configuration) may be placed between the first switching element 120 and the second switching element 130.

[0131] A person skilled in the art will, of course, recognize that modifications other than those described above can be made.

[0132] In particular, it would be understood that example embodiments described above may be combined.

[0133] For example, the controller 100 may be arranged to perform steps S112 and S114 of FIG. 2, and steps S210 and

S212 of FIG. 4, either in parallel or sequentially. The controller 100 may therefore be arranged to detect, in step S116, the fault of the second switching element 130 based on either the determination in step S114, the determination in step S212, or both. Similarly, the controller 100 may be arranged to perform steps S124 and S126 of FIG. 2 and steps S222 and S224 of FIG. 4, either in parallel or sequentially, and to detect a fault in step S128 based on the determination in step S126, the determination in step S224, or both.

[0134] Although in the above described method, the detection of a fault is based on a single comparison (e.g. based on a single comparison of a temperatures at step S114 or at step S126, or based on a single comparison of a measured voltage at step S212 or at step S224), the controller may be arranged to perform multiple comparisons, and to detect a fault only if multiple comparisons indicate that a fault occurs in the switching element. For example, the controller 100 may obtain a temperature value at multiple time instants during the first time period and/or during the second time period, and the controller 100 may detect a fault if the multiple values indicate a continued increase in temperature. As another example, the controller 100 may obtain a value of the voltage across the shunt resistor 162 at multiple time instants during the first time period and/or during the second time period, and the controller 100 may detect a fault if multiple voltage values are not equal to zero.

[0135] Software embodiments of the examples presented herein may be provided as, a computer program, or software, such as one or more programs having instructions or sequences of instructions, included or stored in an article of manufacture such as a machine-accessible or machine-readable medium, an instruction store, or computer-readable storage device, each of which can be non-transitory, in one example embodiment. The program or instructions on the non-transitory machine-accessible medium, machine-readable medium, instruction store, or computer-readable storage device, may be used to program a computer system or other electronic device. The techniques described herein are not limited to any software configuration. They may find applicability in any computing or processing environment. The terms “computer-readable”, “machine-accessible medium”, “machine-readable medium”, “instruction store”, and “computer-readable storage device” used herein shall include any medium that is capable of storing, encoding, or transmitting instructions or a sequence of instructions for execution by the machine, computer, or computer processor and that causes the machine/computer/computer processor to perform any one of the methods described herein. Furthermore, it is common in the art to speak of software, in one form or another (e.g., program, procedure, process, application, module, unit, logic, and so on), as taking an action or causing a result. Such expressions are merely a shorthand way of stating that the execution of the software by a processing system causes the processor to perform an action to produce a result.

[0136] Some embodiments may also be implemented by the preparation of application-specific integrated circuits, field-programmable gate arrays, or by interconnecting an appropriate network of conventional component circuits.

[0137] Some embodiments include a computer program product. The computer program product may be a storage medium or media, instruction store(s), or storage device(s), having instructions stored thereon or therein which can be used to control, or cause, a computer or computer processor

to perform any of the procedures of the example embodiments described herein. The storage medium/instruction store/storage device may include, by example and without limitation, an optical disc, a ROM, a RAM, an EPROM, an EEPROM, a DRAM, a VRAM, a flash memory, a flash card, a magnetic card, an optical card, nanosystems, a molecular memory integrated circuit, a RAID, remote data storage/archive/warehousing, and/or any other type of device suitable for storing instructions and/or data.

[0138] Stored on any one of the computer-readable medium or media, instruction store(s), or storage device(s), some implementations include software for controlling both the hardware of the aerosol generation device and for enabling the aerosol generation device or microprocessor to operate in accordance with the example embodiments described herein. Such software may include without limitation device drivers, operating systems, and user applications. Ultimately, such computer-readable media or storage device(s) further include software for performing example aspects of the invention, as described above.

[0139] Included in the programming and/or software of the aerosol generation device are software modules for implementing the procedures described herein. In some example embodiments herein, a module includes software, although in other example embodiments herein, a module includes hardware, or a combination of hardware and software.

[0140] While various example embodiments of the present invention have been described above, it should be understood that they have been presented by way of example, and not limitation. It will be apparent to persons skilled in the relevant art(s) that various changes in form and detail can be made therein. Thus, the present invention should not be limited by any of the above described example embodiments, but should be defined only in accordance with the following claims and their equivalents.

[0141] Further, the purpose of the Abstract is to enable the Patent Office and the public generally, and especially the scientists, engineers and practitioners in the art who are not familiar with patent or legal terms or phraseology, to determine quickly from a cursory inspection the nature and essence of the technical disclosure of the application. The Abstract is not intended to be limiting as to the scope of the example embodiments presented herein in any way. It is also to be understood that any procedures recited in the claims need not be performed in the order presented.

[0142] While this specification contains many specific embodiment details, these should not be construed as limitations on the scope of any inventions or of what may be claimed, but rather as descriptions of features specific to particular embodiments described herein. Certain features that are described in this specification in the context of separate embodiments can also be implemented in combination in a single embodiment. Conversely, various features that are described in the context of a single embodiment can also be implemented in multiple embodiments separately or in any suitable sub-combination. Moreover, although features may be described above as acting in certain combinations and even initially claimed as such, one or more features from a claimed combination can in some cases be excised from the combination, and the claimed combination may be directed to a sub-combination or variation of a sub-combination.

[0143] In certain circumstances, multitasking and parallel processing may be advantageous. Moreover, the separation of various components in the embodiments described above should not be understood as requiring such separation in all embodiments.

[0144] Having now described some illustrative embodiments and embodiments, it is apparent that the foregoing is illustrative and not limiting, having been presented by way of example. In particular, although many of the examples presented herein involve specific combinations of apparatus or software elements, those elements may be combined in other ways to accomplish the same objectives. Acts, elements and features discussed only in connection with one embodiment are not intended to be excluded from a similar role in other embodiments or embodiments.

[0145] The apparatuses described herein may be embodied in other specific forms without departing from the characteristics thereof. Scope of the apparatuses described herein is thus indicated by the appended claims, rather than the foregoing description, and changes that come within the meaning and range of equivalence of the claims are embraced therein.

LIST OF REFERENCE SIGNS

- [0146]** 10: aerosol generation device
- [0147]** 100: controller (e.g. MCU)
- [0148]** 110: heating arrangement
- [0149]** 120: first switching element (e.g. MOSFET)
- [0150]** 130: second switching element (e.g. MOSFET)
- [0151]** 140: electrical power source
- [0152]** 142: battery
- [0153]** 144: battery protection circuit
- [0154]** 150: charging arrangement
- [0155]** 152: connector (e.g. USB connector)
- [0156]** 154: charging IC
- [0157]** 160: current measuring arrangement
- [0158]** 162: shunt resistor
- [0159]** 164: current measurement element

1. A method for an aerosol generation device, wherein the device comprises a heating arrangement for heating an aerosol substrate, an electrical power source, a first switching element for controlling a supply of electrical power from the electrical power source to the heating arrangement, and a second switching element for decoupling the heating arrangement from the electrical power source, wherein the heating arrangement, the first switching element and the second switching element are arranged in series between terminals of the electrical power source,

the method comprising detecting a fault in the device by: controlling, during a first time period, one of the first switching element and the second switching element to be on and other one of the first switching element and the second switching element to be off, and determining whether at least one observable event occurs during the first time period, the at least one observable event indicating that an amount of power is transferred to the heating arrangement,

wherein a fault is detected in the other one of the first switching element and the second switching element if the at least one observable event is determined to occur during the first time period.

2. The method of claim 1, wherein the detecting comprises:

controlling, during a second time period different from the first time period, the one of the first switching element and the second switching element to be off and the other one of the first switching element and the second switching element to be on, and

determining whether the at least one observable event occurs during the second time period,

wherein a fault is detected in the one of the first switching element and the second switching element if the at least one observable event is determined to occur during the second time period.

3. The method of claim 1, further comprising disabling the heating arrangement upon detecting a fault.

4. The method of claim 1, wherein the at least one observable event comprises an increase of a temperature of the heating arrangement.

5. The method of claim 4, further comprising:

measuring, prior to the first time period, the temperature of the heating arrangement, and

performing the detecting if the measured temperature is below a predetermined threshold.

6. The method of claim 1, wherein the at least one observable event comprises detecting an electrical current flowing from the electrical power source to the heating arrangement.

7. The method of claim 1, wherein the method is performed upon detecting that the device is coupled to an electrical power supply.

8. The method of claim 1, wherein the method is performed upon detecting a decrease in a temperature of the heating arrangement indicating an end of a use of the device.

9. The method of claim 1, wherein the method is performed upon detecting a start of a use of the device.

10. A non-transitory computer-readable medium comprising a computer program comprising instructions which, when executed by at least one processor, cause the at least one processor to execute the method of claim 1.

11. A controller for an aerosol generation device arranged to perform, when in use, the method according to claim 1.

12. An aerosol generation device comprising:

the controller of claim 11,

a heating arrangement for heating an aerosol substrate, an electrical power source,

a first switching element for controlling a supply of electrical power from the electrical power source to the heating arrangement, and

a second switching element for decoupling the heating arrangement from the electrical power source, wherein the heating arrangement, the first switching element and the second switching element are arranged in series between terminals of the electrical power source.

* * * * *