

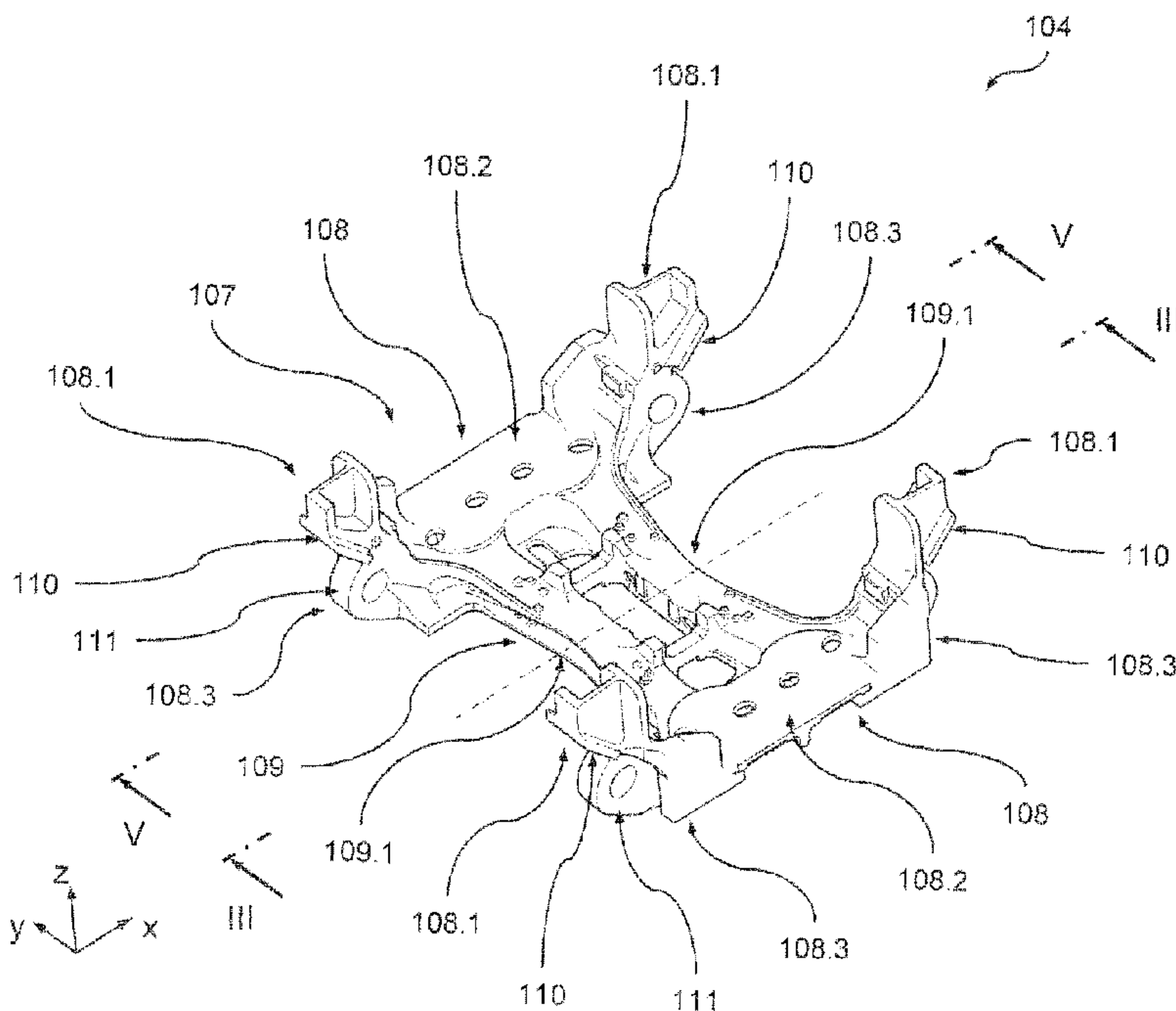

(86) Date de dépôt PCT/PCT Filing Date: 2013/05/29
 (87) Date publication PCT/PCT Publication Date: 2013/12/05
 (45) Date de délivrance/Issue Date: 2017/08/01
 (85) Entrée phase nationale/National Entry: 2014/11/26
 (86) N° demande PCT/PCT Application No.: EP 2013/061133
 (87) N° publication PCT/PCT Publication No.: 2013/178717
 (30) Priorité/Priority: 2012/05/30 (EP12170083.5)

(51) Cl.Int./Int.Cl. *B61F 5/52* (2006.01)
 (72) Inventeur/Inventor:
 ZANUTTI, CEDRIC, BE
 (73) Propriétaire/Owner:
 BOMBARDIER TRANSPORTATION GMBH, DE
 (74) Agent: BENOIT & COTE INC.

(54) Titre : CHASSIS D'ORGANE DE ROULEMENT POUR VEHICULE FERROVIAIRE
 (54) Title: RUNNING GEAR FRAME FOR A RAIL VEHICLE



(57) Abrégé/Abstract:

The present invention relates to a running gear frame for a rail vehicle, comprising a frame body (107) defining a longitudinal direction, a transverse direction and a height direction. The frame body (107) comprises two longitudinal beams (108) and a transverse beam unit (109) providing a structural connection between the longitudinal beams (108) in the transverse direction, such that a substantially H-shaped configuration is formed. Each longitudinal beam (108) has a free end section (108.1) forming a primary suspension interface (110) for a primary suspension device (105.1) connected to an associated wheel unit (103). Each longitudinal beam (108) has a pivot interface section (111) associated to the free end section (108.1) and forming a pivot interface for a pivot arm (112) connected to the associated wheel unit (103). Each longitudinal beam (108) has an angled section (108.3) associated to the free end section (108.1), the angled section (108.3) being arranged such that the free end section (108.1) forms a pillar section at least mainly extending in the height direction, the pivot interface section (111) being associated to the angled section (108.3). The pivot interface section (111) is integrated into to the angled section (108.3) and the frame body (107) is formed as a monolithically cast component made of a grey cast iron material.

(12) INTERNATIONAL APPLICATION PUBLISHED UNDER THE PATENT COOPERATION TREATY (PCT)

(19) World Intellectual Property
Organization
International Bureau(43) International Publication Date
5 December 2013 (05.12.2013)(10) International Publication Number
WO 2013/178717 A1

- (51) International Patent Classification:
B61F 5/52 (2006.01)
- (21) International Application Number:
PCT/EP2013/061133
- (22) International Filing Date:
29 May 2013 (29.05.2013)
- (25) Filing Language: English
- (26) Publication Language: English
- (30) Priority Data:
12170083.5 30 May 2012 (30.05.2012) EP
- (71) Applicant: **BOMBARDIER TRANSPORTATION GMBH** [DE/DE]; Schöneberger Ufer 1, 10785 Berlin (DE).
- (72) Inventor: **ZANUTTI, Cedric**; Sartia Str. 200, B-5070 Sart-Eustache (BE).
- (74) Agent: **KARLHUBER, Mathias**; COHAUSZ & FLORACK, Bleichstraße 14, 40211 Düsseldorf (DE).
- (81) Designated States (*unless otherwise indicated, for every kind of national protection available*): AE, AG, AL, AM,

AO, AT, AU, AZ, BA, BB, BG, BH, BN, BR, BW, BY, BZ, CA, CH, CL, CN, CO, CR, CU, CZ, DE, DK, DM, DO, DZ, EC, EE, EG, ES, FI, GB, GD, GE, GH, GM, GT, HN, HR, HU, ID, IL, IN, IS, JP, KE, KG, KN, KP, KR, KZ, LA, LC, LK, LR, LS, LT, LU, LY, MA, MD, ME, MG, MK, MN, MW, MX, MY, MZ, NA, NG, NI, NO, NZ, OM, PA, PE, PG, PH, PL, PT, QA, RO, RS, RU, RW, SC, SD, SE, SG, SK, SL, SM, ST, SV, SY, TH, TJ, TM, TN, TR, TT, TZ, UA, UG, US, UZ, VC, VN, ZA, ZM, ZW.

- (84) Designated States (*unless otherwise indicated, for every kind of regional protection available*): ARIPO (BW, GH, GM, KE, LR, LS, MW, MZ, NA, RW, SD, SL, SZ, TZ, UG, ZM, ZW), Eurasian (AM, AZ, BY, KG, KZ, RU, TJ, TM), European (AL, AT, BE, BG, CH, CY, CZ, DE, DK, EE, ES, FI, FR, GB, GR, HR, HU, IE, IS, IT, LT, LU, LV, MC, MK, MT, NL, NO, PL, PT, RO, RS, SE, SI, SK, SM, TR), OAPI (BF, BJ, CF, CG, CI, CM, GA, GN, GQ, GW, KM, ML, MR, NE, SN, TD, TG).

Published:

— with international search report (Art. 21(3))

(54) Title: RUNNING GEAR FRAME FOR A RAIL VEHICLE

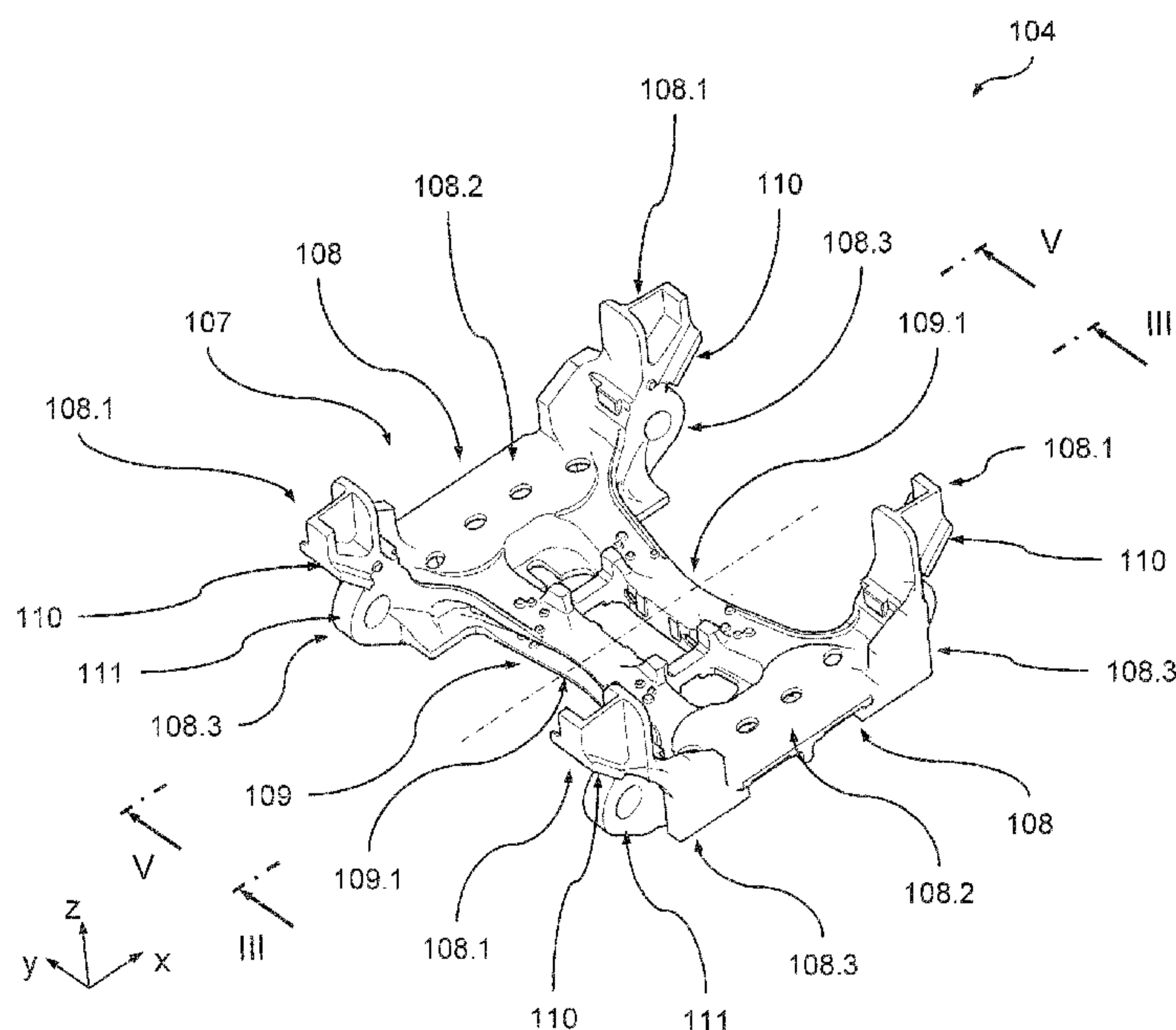

Fig. 2

(57) Abstract: The present invention relates to a running gear frame for a rail vehicle, comprising a frame body (107) defining a longitudinal direction, a transverse direction and a height direction. The frame body (107) comprises two longitudinal beams (108) and a transverse beam unit (109) providing a structural connection between the longitudinal beams (108) in the transverse direction, such that a substantially H-shaped configuration is formed. Each longitudinal beam (108) has a free end section (108.1) forming a primary suspension interface (110) for a primary suspension device (105.1) connected to an associated wheel unit (103). Each longitudinal beam (108) has a pivot interface section (111) associated to the free end section (108.1) and forming a pivot interface for a pivot arm (112) connected to the associated wheel unit (103). Each longitudinal beam (108) has an angled section (108.3) associated to the free end section (108.1), the angled section (108.3) being arranged such that the free end section (108.1) forms a pillar section at least mainly extending in the height direction, the pivot interface section (111) being associated to the angled section (108.3). The pivot interface section (111) is integrated into the angled section (108.3) and the frame body (107) is formed as a monolithically cast component made of a grey cast iron material.

to the angled section (108.3). The pivot interface section (111) is integrated into the angled section (108.3) and the frame body (107) is formed as a monolithically cast component made of a grey cast iron material.

RUNNING GEAR FRAME FOR A RAIL VEHICLE

BACKGROUND OF THE INVENTION

The present invention relates to a running gear frame for a rail vehicle comprising a frame body defining a longitudinal direction, a transverse direction and a height direction. The frame body comprises two longitudinal beams and a transverse beam unit providing a structural connection between the longitudinal beams in the transverse direction, such that a substantially H-shaped configuration is formed. Each longitudinal beam has a free end section forming a primary suspension interface for a primary suspension device connected to an associated wheel unit. Furthermore, each longitudinal beam has a pivot interface section associated to the free end section and forming a pivot interface for a pivot arm connected to the associated wheel unit. Finally, each longitudinal beam has an angled section associated to the free end section, the angled section being arranged such that the free end section forms a pillar section at least mainly extending in the height direction, the pivot interface section being associated to the angled section. The invention furthermore relates to a rail vehicle unit with a running gear frame according to the invention and to a method for producing such a running gear frame according to the invention.

Such a running gear frame is, for example, known from DE 41 36 926 A1 . This running gear frame, due to its specific design of the support on the wheel units (such as wheel pairs or wheels sets etc.) is particularly well suited for the use in low floor vehicles, such as tramways or the like. However, due to this support using a horizontally arranged primary spring resting against a pillar element which is considerably retracted in the longitudinal direction with respect to the pivot interface, the running gear frame has a very complex, multiply branched geometry. Hence, just like for many other structural components for rail vehicles, the production of the running gear frame known from DE 41 36 926 A1, not least due to its comparatively complex geometry, is performed by welding sheet material. This production method, however, has the disadvantage that it requires a relatively large percentage of manual labor, which makes the production of running gear frames comparatively expensive.

The percentage of cost intensive manual labor can be reduced in principle, when cast components are used instead of a welded construction. Thus, it is known e.g. from

GB 1 209 389 A or from US 6,622,776 B2 to use cast steel components for a vehicle frame of a rail vehicle. While a one piece cast bogie frame is produced according to GB 1 209 389 A, according to U.S. 6,622,776 B2 the longitudinal beams and transverse beams of a bogie are made of one or plural standard cast steel components and are subsequently joined to form a bogie frame.

Cast steel has the advantage that conventional welding may be used as a joining technique. The cast steel, however, has the disadvantage that it has a rather limited flow capability. In conjunction with automated production of relatively large components with complex geometries, like e.g. running gear frames for rail vehicles, this leads to reduced process reliability, which is not acceptable in view of the high safety requirements which are given for a running gear of a rail vehicle. Therefore, also when producing such running gear frames from cast steel material, relatively many process steps still have to be performed manually and therefore no economically satisfactory degree of automation can be achieved with this process either, provided that the automation works at all.

To proceed to automated casting it has been proposed in WO 2008/000657 A1 to use grey cast iron as the casting material. While it is also suggested to cast entire running gear frames of comparatively simple, predominantly two-dimensional geometry in a single piece, typically, running gear frames of more complex geometry are also manufactured by cold-joining a plurality of cast components. This again adds to the percentage of cost intensive manual labor.

SUMMARY OF THE INVENTION

Thus, it is the object of the present invention to provide a running gear frame as described above, which does not show the disadvantages described above, or at least shows them to a lesser extent, and which, in particular, facilitates simple production and thus an increased degree of automation of the production.

The present invention is based on the technical teaching that more simple producibility and, thus, an increased degree of automation can be accomplished in the manufacture of a

generic running gear frame of more complex, generally three-dimensional geometry, if the pivot interface section is integrated into the angled section, thereby providing a noticeable reduction in the complexity of the frame geometry which makes it possible to use a grey cast iron material for forming the frame body as a monolithically cast component (i.e. forming the frame body in a single cast piece) in an automated casting process.

While integration of the pivot interface section into the angled section leads to a smoother, less branched geometry of the frame body, the grey cast iron has the advantage that it comprises a particularly good flow capability during casting due to its high carbon content and thus leads to a very high level of process reliability. It has turned out that, due to this geometric modification, a switch to grey cast iron was feasible allowing the production of such a comparatively large frame body of complex, generally three-dimensional geometry in conventional molding boxes of automated casting production lines. Consequently, production of the frame body is significantly simplified and rendered more cost effective. In fact, it has turned out that, compared to a conventional welded running gear frame, a cost reduction by more than 50% may be achieved with such an automated casting process.

An advantage of the grey cast iron material is its improved damping property compared to the steel material which is typically used. This is particularly advantageous with respect to reducing the transmission of vibrations into the passenger compartment of a rail vehicle.

The grey cast iron material can be any suitable grey cast iron material. Preferably, it is a so called nodular graphite iron cast material or spheroidal graphite iron (SGI) cast material. So called austempered ductile iron (ADI) cast material may also be used. Hence, EN-GJS materials as currently specified in European Norms EN 1563 (for SGI materials) and EN 1564 (for ADI materials) may be used. Particularly suitable materials are EN-GJS-400 materials (as specified in European Norm EN 1563), which provide a good compromise between strength, elongation at fracture and toughness. Preferably, EN-GJS-400-18U LT is used, which is characterized by advantageous toughness at low temperatures. Another preferred material would be EN-GJS-350-22-LT.

According to one aspect, the present invention relates to a running gear frame for a rail vehicle, comprising a frame body defining a longitudinal direction, a transverse direction and a height direction. The frame body comprises two longitudinal beams and a transverse beam unit providing a structural connection between the longitudinal beams in the transverse direction, such that a substantially H-shaped configuration is formed. Each longitudinal beam has a free end section forming a primary suspension interface for a primary suspension

device connected to an associated wheel unit. Each longitudinal beam has a pivot interface section associated to the free end section and forming a pivot interface for a pivot arm connected to the associated wheel unit. Furthermore, each longitudinal beam has an angled section associated to the free end section, the angled section being arranged such that the free end section forms a pillar section at least mainly extending in the height direction, the pivot interface section being associated to the angled section. Finally, the pivot interface section is integrated into to the angled section, and the frame body is formed as a monolithically cast component made of a grey cast iron material.

As mentioned above, any desired and suitable grey cast iron material may be used. Preferably, the frame body is made of a spheroidal graphite iron cast material, the spheroidal graphite iron cast material preferably being one of EN-GJS-400-18U LT and EN-GJS-350-22-LT.

Integration of the pivot interface section into the angled section may be achieved by any suitable geometry avoiding a split of the structure in separate branches (as it is known from the prior art structures), which the material flow would have to follow during casting. Preferably, the pivot interface section, in the longitudinal direction, is arranged to be at least partially retracted behind the associated free end section, thereby here simple manner achieving such an integration of the pivot interface section into the angled section.

With typical variants of the invention, a forward free end section and a rearward free end section of one of the longitudinal beams, in the longitudinal direction, define a maximum longitudinal beam length of the longitudinal beam. Furthermore, typically, a forward pivot interface section is associated to the forward free end section and a rearward pivot interface section is associated to the rearward free end section, the forward pivot interface section and the rearward pivot interface section, in the longitudinal direction, defining a maximum pivot interface dimension of the longitudinal beam. Preferably, the maximum pivot interface dimension is 70% to 110%, preferably 80% to 105%, more preferably 90% to 95%, of the maximum longitudinal beam length, thereby achieving a very compact design showing (if at all) only a comparatively moderate longitudinal protrusion in the area at the pivot interface and, hence, yielding appropriate boundary conditions for optimized material flow during casting which is essential in an automated casting process.

With certain embodiments of the invention showing a very beneficial degree of integration of the pivot interface into the angled section, a forward pivot interface section associated to the forward free end section defines a forward pivot axis for a forward pivot arm, while a rearward

5 pivot interface section associated to the rearward free end section defines a rearward pivot axis for a rearward pivot arm. The forward pivot axis and the rearward pivot axis, in the longitudinal direction, define a pivot axis distance, the pivot axis distance being 60% to 90%, preferably 70% to 80%, more preferably 72% to 78%, of the maximum longitudinal beam length.

10 It has turned out that, within the design specifications as outlined herein, suitability for automated casting may be achieved for running gear frame bodies having a considerable size in all three dimensions in space, in particular, not only in the "horizontal" plane (i.e. the plane parallel to the longitudinal direction and the transverse direction) but also in the height direction. Hence, with certain embodiments of the invention, in the height direction, one of the longitudinal beams, in a longitudinally central section, defines a longitudinal beam underside and a maximum central beam height of the longitudinal beam above the longitudinal beam underside, while one of the free end sections of the longitudinal beam defines a maximum beam height above the longitudinal beam underside. The maximum beam height is 200% to 450%, preferably 300% to 400%, more preferably 370% to 380%, of the maximum central beam height. Such a considerable height dimension of the pillar section facilitates, among others, a modification of the arrangement of the primary suspension unit (namely a switch from the known horizontal arrangement to an inclined arrangement) as will be explained in further detail in the following.

20 Basically, the primary suspension acting between the wheel unit and the associated primary suspension interface section at the respective free end of the respective longitudinal beam may have any desired and suitable orientation in space. Furthermore, typically, the primary suspension interface is configured to take a total resultant support force acting on the free end section when the frame body is supported on the associated wheel unit (i.e. the force being the result of the all the forces acting via the primary suspension on the free end when the running gear frame is supported on the wheel unit). In these cases, the total resultant support force acting on the respective free end may have any desired and suitable orientation in space. Hence, for example, the resultant total support force may be parallel with respect to the height direction or parallel to the longitudinal direction.

30 However, with preferred embodiments of the invention, the primary suspension interface is configured such that the total resultant support force is inclined with respect to the longitudinal direction and/or inclined with respect to the height direction. An inclination of the total resultant support force with respect to both the longitudinal direction and the height direction, in particular, allows realization of very beneficial configurations in terms of the

required building space as well with respect to manufacturing and maintenance aspects. For example, such an inclined total resultant support force yields the possibility to realize a connection between the pivot arm and the frame body at the pivot interface which is both self adjusting under load (due to the components of the total resultant force acting in the longitudinal direction and the height direction) while being easily dismounted in absence of the support load as it is described in greater detail in pending German patent application No. 10 2011 110 090.7. Preferably, the total resultant support force is inclined with respect to said height direction by a primary suspension angle, the primary suspension angle ranging from 20° to 80°, preferably from 30° to 70°, more preferably from 40° to 50°, since these values, among others, are particularly beneficial in terms of a space-saving design.

It should be noted that, unless stated otherwise in the following, all statements with respect to inclination of the total resultant force refer to a static state with a rail vehicle standing on a straight level track under its nominal load.

The primary suspension interface may have any desired shape. For example, one or more separate interface surfaces may be realized. These interface surfaces may furthermore have any desired shape, for example, a section wise planar shape, a section wise curved shape as well as a section wise stepped shape etc.

With advantageous embodiments of the invention, the primary suspension interface defines a main interface plane, the main interface plane being configured to take at least a major fraction of the total resultant support force. The main interface plane is inclined with respect to the longitudinal direction and/or inclined with respect to the height direction. Here as well, preferably, a configuration inclined with respect to the height direction is chosen. Hence, preferably, the main interface plane is inclined with respect to the height direction by a main interface plane angle, the main interface plane angle ranging from 20° to 80°, preferably from 30° to 70°, more preferably from 40° to 50°. Furthermore, preferably, the main interface plane is substantially parallel with respect to the transverse direction which leads to a configuration which is very simple to manufacture and leads to an advantageous introduction of the forces into the frame body.

Basically, any desired and suitable relative position may be selected between the primary suspension interface and the pivot interface. However, preferably, the pivot interface section, in the longitudinal direction, is arranged to be at least partially retracted behind a center of the primary suspension interface, which results in a very simple design of the pillar section which

is beneficial under many manufacturing aspects, in particular, the suitability of the frame body for using an automated casting process. Furthermore, such a configuration is beneficial in terms of the design of the pivot arm and the introduction of the support loads into the frame body.

5 Typically, a center of a forward primary suspension interface and a center of a rearward primary suspension interface of one of the longitudinal beams, in the longitudinal direction, define a maximum primary suspension interface center distance. Furthermore, typically, a forward pivot interface section is associated to the forward primary suspension interface and defines a forward pivot axis for a forward pivot arm, while a rearward pivot interface section is
10 associated to the rearward primary suspension interface and defines a rearward pivot axis for a rearward pivot arm, the forward pivot axis and the rearward pivot axis, in the longitudinal direction, defining a pivot axis distance. Preferably, the pivot axis distance is 60% to 105%, preferably 70% to 95%, more preferably 80% to 85%, of the maximum longitudinal beam length. Such a configuration is particularly beneficial in terms of the design of the pivot arm
15 and the introduction of the support loads into the frame body.

Basically, the primary suspension unit and, consequently, the primary suspension interface may have any desired and suitable shape. For example, any desired type and/or number of primary spring elements may be used in connection with an appropriate interface. With
20 certain preferred embodiments of the invention having a very simple design, the primary suspension interface is configured as an interface for a single primary suspension device. Preferably, the primary suspension device is formed by a single primary suspension unit, which, further preferably, is formed by a single primary suspension spring, leading to a design which is very simple and easy to manufacture. Any type of primary spring may be used. Preferably, due to its compact and robust design, a rubber-metal-spring unit is used for the
25 primary spring.

The transverse beam unit may be of any desired shape and design. For example, it may comprise one or more transverse beams interconnecting the two longitudinal beams. Such a transverse beam may have any desired cross-section. For example, such a transverse beam may have a generally box shaped design with a closed or generally ring-shaped cross-
30 section. However, many other types of transverse beams may be chosen. For example, a conventional I-beam shape may be chosen.

Preferably, the transverse beam unit comprises at least one transverse beam, the at least one transverse beam, in a sectional plane parallel to the longitudinal direction and the height

direction, defining a substantially C-shaped cross section. Such an open design has the advantage that (despite the general rigidity of the materials used) the transverse beam is comparatively torsionally soft, i.e. shows a comparatively low resistance against torsional moments about the transverse axis (compared to a closed, generally box shaped design and the transverse beam). This is particularly advantageous with respect to the derailment safety of the running gear since the running the frame itself is able to provide some torsional deformation tending to equalize the wheel to rail contact forces on all four wheels.

Generally, any desired orientation of the substantially C-shaped cross section may be chosen. This may be done, in particular, as a function of the amount and/or orientation of the bending loads to be taken up by the transverse beam. Preferably, the substantially C-shaped cross section is arranged such that, in the longitudinal direction, it is open towards a free end of the frame body and, in particular, substantially closed towards a center of the frame body. Such a configuration is particularly beneficial if more than one transverse beams are used and a focus is to be put on a low torsional rigidity of the transverse beam unit.

The substantially C-shaped cross section may be arranged at any transverse position in the transverse beam unit. Preferably, the C-shaped cross section, in the transverse direction, extends over a transversally central section of the transverse beam unit, since at this location, a particularly beneficial influence on the torsional rigidity of the transverse beam unit may be achieved.

The substantially C-shaped cross section may extend over the entire extension of the transverse beam unit in the transverse direction. Preferably, the substantially C-shaped cross section extends, in the transverse direction, over a transverse dimension, the transverse dimension being at least 50%, preferably at least 70%, more preferably 80% to 95%, of a transverse distance between longitudinal center lines of the longitudinal beams in the area of the transverse beam unit. By this means a particularly advantageous torsional rigidity may be achieved even with such a grey cast iron frame body.

With preferred embodiments of the invention the at least one transverse beam is a first transverse beam and the transverse beam unit comprises a second transverse beam. Such a configuration has the advantage that, compared to a configuration with one single transverse beam, the mechanical properties may be more easily tuned to the requirements of the specific running gear. Preferably, the first transverse beam and the second transverse beam are substantially symmetric with respect to a plane of symmetry parallel to the

transverse direction and the height direction, thereby providing identical running properties irrespective of the direction of travel.

Moreover, with transverse beams having C-shaped cross sections the open sides of which are facing away from each other, the increase in the overall torsional rigidity of the transverse beam unit resulting from the fact that two transverse beams are used may be kept
5 comparatively low. This is due to the fact that the closed sides of the two transverse beams (in the longitudinal direction) are located comparatively centrally within the transverse beam unit, such that their contribution to the torsional resistance moment is comparatively low.

Furthermore, preferably, the first transverse beam and the second transverse beam are
10 separated, in the longitudinal direction, by a gap having a longitudinal gap dimension. Such a gap between the two transverse beams has in the advantage that the bending resistance in the plane of main extension of the two beams is increased without adding to the mass of the frame body, such that a comparatively lightweight configuration is achieved. Furthermore, such a gap is readily available for receiving other components of the running gear, which is
15 particularly beneficial in modern rail vehicles with their severe constraints regarding the building space available.

The longitudinal gap dimension may be selected as desired. Preferably, the longitudinal gap dimension is 70% to 120%, preferably 85% to 110%, more preferably 95% to 105%, of a minimum longitudinal dimension of one of the transverse beams in the longitudinal direction,
20 thereby achieving a well-balanced configuration showing both, comparatively low torsional rigidity (about the transverse direction) and comparatively high bending rigidity (about the height direction).

The first and second transverse beam may be of any desired general shape. Preferably, the first transverse beam and the second transverse beam each define a transverse beam center
25 line, at least one of the transverse beam center lines, at least section wise, having a generally curved or polygonal shape in a first plane parallel to the longitudinal direction and the transverse direction and/or a second plane parallel to the transverse direction and the height direction. Such generally curved or polygonal shapes of the transverse beam center lines have the advantage that the shape of the transverse beam may be adapted to the distribution
30 of the loads acting on the respective transverse beam resulting in a comparatively smooth distribution of the stresses within the transverse beam and, ultimately, in a comparatively light weight and stress optimized frame body.

With certain preferred embodiments of the invention, the transverse beam unit is a locally waisted unit, in particular a centrally waisted unit, the transverse beam unit having a waisted section defining a minimum longitudinal dimension of the transverse beam unit in the longitudinal direction. Such a waisted configuration, among others, is advantageous in terms of the low torsional rigidity of the frame body about the transverse direction.

Generally, the extent of the waist may be chosen as a function of the mechanical properties, in particular, the torsional rigidity, to be achieved. Preferably, the minimum longitudinal dimension of the transverse beam unit is 40% to 90%, preferably 50% to 80%, more preferably 60% to 70%, of a maximum longitudinal dimension of the transverse beam unit in the longitudinal direction, the maximum longitudinal dimension, in particular, being defined at a junction of the transverse beam unit and one of the longitudinal beams.

With advantageous embodiments of the invention the free end section, in a section facing away from the primary spring interface, forms a stop interface for a stop device. Preferably, the stop device is a rotational stop device and/or longitudinal stop device, which may also be adapted to form a traction link between the frame body and a component, in particular a bolster or a wagon body, supported on the frame body. It will be appreciated that such a configuration is particularly beneficial since it provides a high degree of functional integration leading to a comparatively lightweight overall design.

The present invention furthermore relates to a rail vehicle unit comprising a first running gear frame according to the invention supported on two wheel units via primary spring units and pivot arms connected to the first running gear frame to form a first running gear. A further rail vehicle component may be supported on the frame body, the rail vehicle component, in particular, being a bolster or a wagon body.

It will be appreciated that, according to a further aspect of the present invention, the frame body may be formed as a standardized component which may be used for different types of running gear. Customization of the respective frame body to the specific type of running gear type may be achieved by additional type specific components mounted to the standardized frame body. Such an approach is highly advantageous in terms of its commercial impact. This is due to the fact that, in addition to the considerable savings achieved due to the automated casting process, only one single type of frame body has to be manufactured, which brings along a further considerable reduction in costs.

Hence, preferably, the rail vehicle unit comprises a second running gear frame according to the invention supported on two wheel units via primary spring units and pivot arms connected to the second running gear frame to form a second running gear. The first running gear may be a driven running gear comprising a drive unit, while the second running gear may be a
5 non-driven running gear having a no drive unit. Preferably, at least the frame body of the first running gear frame and the frame body of the second running gear frame are substantially identical.

It should be noted in this context that customization of the running gear to a specific type or function on the basis of identical frame bodies is not limited to a differentiation in terms of
10 driven and non-driven running gears. Any other functional components may be used to achieve a corresponding functional differentiation between such running gears on the basis of standardized identical frame bodies.

Finally, the present invention relates to a method for producing a running gear frame according to the invention, wherein the frame body is cast in a single step, in particular, in an
15 automated casting process.

Further embodiments of the present invention will become apparent from the dependent claims and the following description of preferred embodiments which refers to the appended figures.

BRIEF DESCRIPTION OF THE DRAWINGS

20 Figure 1 is a schematic side view of a part of a preferred embodiment of a rail vehicle according to the present invention with a preferred embodiment of a running gear unit according to the present invention;

Figure 2 is a schematic perspective view of a frame body of the running gear unit of Figure 1;

25 Figure 3 is a schematic sectional view of the frame body of Figure 2 along line III-III of Figure 1.

Figure 4 is a schematic frontal view of the frame body of Figure 2.

Figure 5 is a schematic sectional view of a part of the running gear unit along line V-V of Figure 1.

Figure 6 is a schematic top view of the running gear unit of Figure 1.

DETAILED DESCRIPTION OF THE INVENTION

5 With reference to Figures 1 to 6 a preferred embodiment of a rail vehicle 101 according to the present invention comprising a preferred embodiment of a running gear 102 according to the invention will now be described in greater detail. In order to simplify the explanations given below, an xyz-coordinate system has been introduced into the Figures, wherein (on a straight, level track T) the x-axis designates the longitudinal direction of the rail vehicle 101,
10 the y-axis designates the transverse direction of the rail vehicle 101 and the z-axis designates the height direction of the rail vehicle 101 (the same, of course, applies for the running gear 102). It will be appreciated that all statements made in the following with respect to the position and orientation of components of the rail vehicle, unless otherwise stated, refer to a static situation with the rail vehicle 101 standing on a straight level track
15 under nominal loading.

The vehicle 101 is a low floor rail vehicle such as a tramway or the like. The vehicle 101 comprises a wagon body 101.1 supported by a suspension system on the running gear 102. The running gear 102 comprises two wheel units in the form of wheel sets 103 supporting a running gear frame 104 via a primary spring unit 105. The running gear frame 104 supports
20 the wagon body via a secondary spring unit 106.

The running gear frame 104 has a frame body 107 comprising two longitudinal beams 108 and a transverse beam unit 109 providing a structural connection between the longitudinal beams 108 in the transverse direction, such that a substantially H-shaped configuration is formed. Each longitudinal beam 108 has two free end sections 108.1 and a central section
25 108.2. The central section 108.2 is connected to the transverse beam unit 109 while the free end sections 108.1 form a primary suspension interface 110 for a primary suspension device 105.1 of the primary suspension unit 105 connected to the associated wheel unit 103. In the present example, a compact and robust rubber-metal-spring is used for the primary spring device 105.1.

Each longitudinal beam 108 has an angled section 108.3 associated to one of the free end sections 108.1. Each angled section 108.3 is arranged such that the free end section 108.1 forms a pillar section mainly extending in the height direction. Hence, basically, the frame body 107 has a comparatively complex, generally three-dimensional geometry.

5 Each longitudinal beam 108 has a pivot interface section 111 associated to the free end section 108.1. The pivot interface section 111 forms a pivot interface for a pivot arm 112 rigidly connected to a wheel set bearing unit 103.1 of the associated wheel unit 103. The pivot arm 112 is pivotably connected to the frame body 107 via a pivot bolt connection 113. The pivot bolt connection 113 comprises a pivot bolt 113.1 defining a pivot axis 113.2. The
10 bolt 113.1 is inserted into matching recesses in a forked end of the pivot arm 112 and a pivot interface recess 111.1 in a lug 111.2 of the pivot interface section 111 (the lug 111.2 being received between the end parts of the pivot arm 112).

To reduce the complexity of the frame body 107, the respective pivot interface section 111 is integrated into to the angled section 108.3 of the longitudinal beams 108, such that,
15 nevertheless, a very compact arrangement is achieved. More precisely, integration of the pivot interface section 111 into the angled section 108.3 leads to a comparatively smooth, unbranched geometry of the frame body.

This compact, smooth and unbranched arrangement, among others, makes it possible to form the frame body 107 as a monolithically cast component. More precisely, the frame body
20 107 is formed as a single piece cast in an automated casting process from a grey cast iron material. The grey cast iron material has the advantage that it comprises a particularly good flow capability during casting due to its high carbon content and thus leads to a very high level of process reliability.

Casting is done in conventional molding boxes of an automated casting production line.
25 Consequently, production of the frame body 107 is significantly simplified and rendered more cost effective than in conventional solutions with welded frame bodies. In fact, it has turned out that (compared to a conventional welded frame body) a cost reduction by more than 50% may be achieved with such an automated casting process.

The grey cast iron material used in the present example is a so called nodular graphite iron
30 cast material or spheroidal graphite iron (SGI) cast material as currently specified in European Norm EN 1563. More precisely, a material such as EN-GJS-400-18U LT is used, which provides a good compromise between strength, elongation at fracture and toughness,

in particular at low temperatures. Obviously, depending on the mechanic requirements on the frame body, any other suitable cast material as outlined above may be used.

To achieve proper integration of the pivot interface section 111 into the angled section 108.3, the respective pivot interface section 111, in the longitudinal direction (x-axis), is arranged to
5 be retracted behind the associated free end section 108.1.

In the present example, a forward free end section 108.1 and a rearward free end section 108.1 of each longitudinal beam 108, in the longitudinal direction, define a maximum longitudinal beam length $L_{LB,max}$ of the longitudinal beam 108. Furthermore, a forward pivot interface section 111 (associated to the forward free end section 108.1) and a rearward pivot
10 interface section 111 (associated to the rearward free end section 108.1), in the longitudinal direction, define a maximum pivot interface dimension $L_{PI,max}$ of the longitudinal beam 108.

In the present example, the maximum pivot interface dimension $L_{PI,max}$ is about 92% of the maximum longitudinal beam length $L_{LB,max}$, thereby achieving a very compact design showing no longitudinal protrusion in the area at the pivot interface 111 and, hence, yielding
15 appropriate boundary conditions for optimized material flow during casting which is essential in the automated casting process used.

Furthermore, the forward pivot axis 113.2 (for the forward pivot arm 112) and the rearward pivot axis 113.2 (for the rearward pivot arm 112), in the longitudinal direction, define a pivot axis distance L_{PA} being about 76% of the maximum longitudinal beam length $L_{LB,max}$.

20 The frame body 107 of the present embodiment is suitable for automated casting despite its considerable size in all three dimensions (x,y,z) in space, in particular, its considerable size not only in the "horizontal" plane (i.e. the xy-plane) but also its considerable size in the height direction (z-axis). More precisely, as can be seen from Figure 3, in the height direction, the longitudinally central section 108.2 defines a longitudinal beam underside and a maximum
25 central beam height $H_{LBC,max}$ of the longitudinal beam 108 above the longitudinal beam underside, while the free end sections 108.1 define a maximum beam height $H_{LB,max}$ above the longitudinal beam underside. Despite the fact that the maximum beam height $H_{LB,max}$ of the present embodiment is as high as about 380% of the maximum central beam height $H_{LBC,max}$, the frame body 107 may be cast as a single monolithic component.

30 According to a further aspect of the present invention (as can be seen, in particular, from Figure 5) a considerable reduction in the building space (required for frame body 107 within

the running gear 102) is accomplished in that the primary suspension interface 110 is configured such that the total resultant support force F_{TRS} acting in the area of the respective free end 108.1 (i.e. the total force resulting from all the support forces acting via the primary suspension 105 in the region the free end 108.1, when the running gear frame 104 is supported on the wheel unit 103) is substantially parallel with respect to the xz-plane, while being inclined with respect to the longitudinal direction (x-axis) by a primary suspension angle $\alpha_{PSF,x}$ and inclined with respect to the height direction (z-axis) by a complementary primary suspension angle

$$\alpha_{PSF,z} = 90^\circ - \alpha_{PSF,x} \quad (1)$$

Such an inclination of the total resultant support force F_{TRS} , compared to a configuration as known from DE 41 36 926 A1, allows the primary suspension device 105.1 to move closer to the wheel set 103, more precisely closer to the axis of rotation 103.2 of the wheel set 103. This has not only the advantage that the primary suspension interface 110 also can be arranged more closely to the wheel unit, which clearly saves space in the central part of the running gear 102. Furthermore, the pivot arm 112 connected to the wheel set bearing unit 103.1 can be of smaller, more lightweight and less complex design.

Furthermore, such an inclined total resultant support force F_{TRS} yields the possibility to realize a connection between the pivot arm 112 and the frame body 107 at the pivot interface 111 which is both self adjusting under load (due to the components of the total resultant force F_{TRS} acting in the longitudinal direction and the height direction) while being easily dismantled in absence of the support load F_{TRS} as it is described in greater detail in pending German patent application No. 10 2011 110 090.7 (the entire disclosure of which is incorporated herein by reference).

Finally, such a design has the advantage that, not least due to the fact that the primary suspension interface section 110 moves closer to the wheel set 103, it further facilitates automated production of the frame body 107 using an automated casting process.

Although, basically, the total resultant support force F_{TRS} may have any desired and suitable inclination with respect to the longitudinal direction and the height direction, in the present example, the total resultant support force F_{TRS} is inclined with respect to the longitudinal direction by a primary suspension angle $\alpha_{PSF,x} = 45^\circ$. Consequently, the total resultant support force is inclined with respect to the height direction by a complementary primary

suspension angle $\alpha_{PSF,z} = 90^\circ - \alpha_{PSF,x} = 45^\circ$. Such an inclination provides a particularly compact and, hence, favorable design. Furthermore, it also provides an advantageous introduction of the support loads F_{TRS} from the wheel set 103 into the frame body 107. Finally, as a consequence, the pillar section or end section 108.1 may be formed in a slightly forward leaning configuration which is favorable in terms of facilitating cast material flow and, hence, use of an automated casting process.

As may be further seen from Figure 5, the primary suspension interface 110 and the primary suspension device 105.1 are arranged such that the total resultant support force F_{TRS} intersects a wheel set shaft 103.3 of the wheel set 103, leading to a favorable introduction of the support loads from the wheel set 103 into the primary suspension device 105.1 and onwards into the frame body 107. More precisely, the total resultant support force F_{TRS} intersects the axis of wheel rotation 103.2 of the wheel shaft 103.3.

Such a configuration, among others, leads to a comparatively short lever arm of the total resultant support force F_{TRS} (for example, a lever arm A_{TRS} at the location of the pivot bolt 113.1) and, hence, comparatively low bending moments acting in the longitudinal beam 108, which, in turn, allows a more lightweight design of the frame body 107.

A further advantage of the configuration as outlined above is the fact that the pivot arm 112 may have a very simple and compact design. More precisely, in the present example, the pivot arm 112 integrating the wheel set bearing unit 103.1, apart from the forked end section (receiving the pivot bolt 113.1) simply has to provide a corresponding support surface for the primary spring device 105.1 located close to the outer circumference of the wheel set bearing unit 103.1. Hence, compared to known configurations, no complex arms or the like are necessary for introducing the support forces into the primary spring device 105.1.

Although, basically, the primary suspension interface 110 may have any desired shape, in the present example, the primary suspension interface 110 is a simple planar surface 110.1 laterally flanked by two protrusions 110.2 (against which mating surfaces of the primary suspension device 105.1 rest, among others, for centering purposes). The planar surface 110.1 defines a main interface plane configured to take a major fraction of the total resultant support force F_{TRS} .

The main interface plane 110.1 is configured to be substantially perpendicular to the total resultant support force F_{TRS} as well as substantially parallel to the transverse direction (y-axis). As a consequence, the main interface plane 110.1 is inclined with respect to the

longitudinal direction and inclined with respect to the height direction. More precisely, the main interface plane 110.1 is inclined with respect to the height direction by a main interface plane angle

$$\alpha_{MIP,z} = 90^\circ - \alpha_{PSF,z} = \alpha_{PSF,x}. \quad (2)$$

5 Hence, in the present case, the main interface plane 110.1 is inclined with respect to the height direction by a main interface plane angle $\alpha_{MIP,z} = 45^\circ$.

To achieve the slightly forwardly leaning configuration of the free end section 108.1 and its advantages as described above, in the present example, the pivot interface section 111, in the longitudinal direction, is retracted behind a center 110.3 of the primary suspension
10 interface 110. To this end, in the present embodiment, the pivot axis distance L_{PA} is 82% of a primary suspension interface center distance L_{PSIC} defined (in the longitudinal direction) by the centers 110.3 of a forward primary suspension interface 110 and a rearward primary suspension interface 110 of the longitudinal beams 108.

The transverse beam unit 109 comprises two transverse beams 109.1, which are arranged to
15 be substantially symmetric to each other with respect to a plane of symmetry parallel to the yz-plane and arranged centrally within the frame body 107. The transverse beams 109.1 (in the longitudinal direction) are separated by a gap 109.5.

As can be seen from Figure 3, each transverse beam 109.1, in a sectional plane parallel to the xz-plane, has a substantially C-shaped cross section with an inner wall 109.2, an upper
20 wall 109.3, and a lower wall 109.4. The C-shaped cross section is arranged such that, in the longitudinal direction, it is open towards the (more closely located) free end of the frame body 107, while it is substantially closed by the inner wall 109.2 located adjacent to the center of the frame body 107. In other words, the open sides of the transverse beams 109.1 are facing away from each other.

25 Such an open design of the transverse beam 109.1 has the advantage that (despite the general rigidity of the materials used) not only the individual transverse beam 109.1 is comparatively torsionally soft, i.e. shows a comparatively low resistance against torsional moments about the transverse y-axis (compared to a closed, generally box shaped design of the transverse beam). The same applies to the transverse beam unit 109 as a whole, since
30 the inner walls 109.2 (in the longitudinal direction) are located comparatively centrally within

the transverse beam unit 109, such that their contribution to the torsional resistance moment about the transverse y-axis is comparatively low.

Furthermore, the gap 109.5, in a central area of the frame body 107, has a maximum longitudinal gap dimension $L_{G,max}$, which is about 100% of a minimum longitudinal dimension $L_{TB,min}$ of one of the transverse beams 109.1 in the longitudinal direction (in the central area of the frame body 107). The gap 109.5 has the advantage that the bending resistance in the plane of main extension of the two transverse beams 109.1 (parallel to the xy-plane) is increased without adding to the mass of the frame body 107, such that a comparatively lightweight configuration is achieved.

Furthermore, the gap 109.5 is readily available for receiving other components of the running gear 102 (such as a transverse damper 114 as shown in Figure 6), which is particularly beneficial in modern rail vehicles with their severe constraints regarding the building space available.

The C-shaped cross section extends over a transversally central section of the transverse beam unit 109, since, at this location, a particularly beneficial influence on the torsional rigidity of the transverse beam unit is achieved. In the present embodiment, the substantially C-shaped cross section extends over the entire extension of the transverse beam unit in the transverse direction (i.e. from one longitudinal beam 108 to the other longitudinal beam 108). Hence, in the present example, the C-shaped cross section extends over a transverse dimension W_{TBC} , which is 85% of a transverse distance W_{LBC} between longitudinal center lines 108.4 of the longitudinal beams 108 in the area of the transverse beam unit 109. By this means a particularly advantageous torsional rigidity may be achieved even with such a grey cast iron frame body 107.

As far as the extension in the transverse direction is concerned, the same (as for the C-shaped cross-section) also applies to the extension of the gap 109.5. Furthermore, it should be noted that the longitudinal gap dimension doesn't necessarily have to be the same along the transverse direction. Any desired gap width may be chosen as needed.

In the present example, each transverse beam 109.1 defines a transverse beam center line 109.6, which has a generally curved or polygonal shape in a first plane parallel to the xy-plane and in a second plane parallel to the yz-plane. Such generally curved or polygonal shapes of the transverse beam center lines 109.6 have the advantage that the shape of the respective transverse beam 109.1 is adapted to the distribution of the loads acting on the

respective transverse beam 109.1 resulting in a comparatively smooth distribution of the stresses within the respective transverse beam 109.1 and, ultimately, in a comparatively lightweight and stress optimized frame body 107.

As a consequence, as can be seen from Figure 2 and 6, the transverse beam unit 109 is a centrally waisted unit with a waisted central section 109.7 defining a minimum longitudinal dimension of the transverse beam unit $L_{TBU,min}$ (in the longitudinal direction) which, in the present example, is 65% of a maximum longitudinal dimension of the transverse beam unit $L_{TBU,max}$ (in the longitudinal direction). This maximum longitudinal dimension, in the present example, is defined at the junction of the transverse beam unit 109 and the longitudinal beams 108.

Generally, the extent of the waist of the transverse beam unit 109 may be chosen as a function of the mechanical properties of the frame body 107 (in particular, the torsional rigidity of the frame body 107) to be achieved. In any case, with the transverse beam unit design as outlined herein, a well-balanced configuration is achieved showing both, comparatively low torsional rigidity (about the transverse direction) and comparatively high bending rigidity (about the height direction). This configuration is particularly advantageous with respect to the derailment safety of the running gear 102 since the running gear frame 104 is able to provide some torsional deformation tending to equalize the wheel to rail contact forces on all four wheels of the wheel sets 103.

And can be further seen from Figure 3 and 6, in the present example, the free end section 108.1, in a section facing away from the primary spring interface 110, forms a stop interface for a stop device 115. The stop devices 115 integrate the functionality of a rotational stop device and a longitudinal stop device for the wagon body 101.1. Furthermore, the stop devices 115 also are adapted to form a traction link between the frame body 107 and the wagon body 101.1 supported on the frame body 107. It will be appreciated that such a configuration is particularly beneficial since it provides a high degree of functional integration leading to a comparatively lightweight overall design.

As can be seen from Figure 1, the wagon body 101.1 (more precisely, either the same part of the wagon body 101.1 also supported on the first running gear 102 or another part of the wagon body 101) is supported on a further, second running gear 116. The second running gear 116 is identical to the first running gear 102 in all the parts described above. However, while the first running gear 102 is a driven running gear with a drive unit (not shown) mounted

to the frame body 107, the second running gear 116 is a non-driven running gear, having no such drive unit mounted to the frame body 107.

Hence, according to a further aspect of the present invention, the frame body 107 forms a standardized component which used for both, the first running gear 102 and the second
5 running gear, i.e. different types of running gear. Customization of the respective frame body 107 to the specific type of running gear type may be achieved by additional type specific components mounted to the standardized frame body 107. Such an approach is highly advantageous in terms of its commercial impact. This is due to the fact that, in addition to the considerable savings achieved due to the automated casting process, only one single type of
10 frame body 107 has to be manufactured, which brings along a further considerable reduction in costs.

It should again be noted in this context that customization of the running gear 102, 116 to a specific type or function on the basis of identical frame bodies 107 is not limited to a differentiation in terms of driven and non-driven running gears. Any other functional
15 components (such as e.g. specific types of brakes, tilt systems, rolling support systems such as an anti-roll-bar device, etc.) may be used to achieve a corresponding functional differentiation between such running gears on the basis of standardized identical frame bodies 107.

Although the present invention, in the foregoing, only has been described in the context of
20 running gears with inboard wheelset bearings, it should be noted that the present invention may also be used in the context of running gears with outboard wheelset bearings. This will require only slight modifications of the running gear frame, in particular, the longitudinal beams, location of components such as magnetic brakes etc. for adaptation to different track gauges.

25 Although the present invention, in the foregoing, only has been described in the context of low-floor rail vehicles, it will be appreciated, however, that it may also be applied to any other type of rail vehicle in order to overcome similar problems with respect to a simple solution for reducing the manufacturing effort.

Claims

1. A running gear frame for a rail vehicle, comprising
 - a frame body defining a longitudinal direction, a transverse direction and a height direction;
 - said frame body comprising two longitudinal beams and a transverse beam unit providing a structural connection between said longitudinal beams in said transverse direction, such that a substantially H-shaped configuration is formed,
 - each longitudinal beam having a free end section forming a primary suspension interface for a primary suspension device connected to an associated wheel unit;
 - each longitudinal beam having a pivot interface section associated to said free end section and forming a pivot interface for a pivot arm connected to said associated wheel unit;
 - each longitudinal beam having an angled section associated to said free end section;
 - said angled section being arranged such that said free end section forms a pillar section at least mainly extending in said height direction;
 - said pivot interface section being associated to said angled section;characterized in that
 - said pivot interface section is integrated into said angled section, and
 - said frame body is formed as a monolithically cast component made of a grey cast iron material.
2. The running gear frame according to claim 1, wherein
 - said frame body is made of a spheroidal graphite iron cast material.
3. The running gear frame according to claim 2, wherein
 - said spheroidal graphite iron cast material is being one of EN-GJS-400-18U LT and EN-GJS-350-22-LT.
4. The running gear frame according to any one of claims 1 to 3, wherein
 - said pivot interface section, in said longitudinal direction, is arranged to be at least partially retracted behind said associated free end section;

- a forward free end section and a rearward free end section of one of said longitudinal beams, in said longitudinal direction, defining a maximum longitudinal beam length of said longitudinal beam;
 - a forward pivot interface section being associated to said forward free end section;
 - a rearward pivot interface section being associated to said rearward free end section;
 - said forward pivot interface section and said rearward pivot interface section, in said longitudinal direction, defining a maximum pivot interface dimension of said longitudinal beam.
5. The running gear frame according to claim 4, wherein said maximum pivot interface dimension is being 70% to 110% of said maximum longitudinal beam length.
6. The running gear frame according to claim 5, wherein said maximum pivot interface dimension is being 80% to 105% of said maximum longitudinal beam length.
7. The running gear frame according to claim 6, wherein said maximum pivot interface dimension is being 90% to 95% of said maximum longitudinal beam length.
8. The running gear frame according to any one of claims 4 to 7, wherein
- the forward pivot interface section associated to said forward free end section defines a forward pivot arm;
 - the rearward pivot interface section associated to said rearward free end section defines a rearward pivot axis for a rearward pivot arm;
 - said forward pivot axis and said rearward pivot axis, in said longitudinal direction, defining a pivot axis distance.
9. The running gear frame according to claim 8, wherein said pivot axis distance is being 60% to 90% of said maximum longitudinal beam length.
10. The running gear frame according to claim 9, wherein said pivot axis distance is being 70% to 80% of said maximum longitudinal beam length.
11. The running gear frame according to claim 10, wherein said pivot axis distance is being 72% to 78% of said maximum longitudinal beam length.

12. The running gear frame according to any one of claims 1 to 11, wherein,
 - in said height direction, one of said longitudinal beams, in a longitudinally central section, defines a longitudinal beam underside and a maximum central beam height of said longitudinal beam above said longitudinal beam underside, and
 - one of said free end sections of said longitudinal beam defines a maximum beam height above said longitudinal beam underside.
13. The running gear frame according to claim 12, wherein said maximum beam height is being 200% to 450% of said maximum central beam height.
14. The running gear frame according to claim 13, wherein said maximum beam height is being 300% to 400% of said maximum central beam height.
15. The running gear frame according to claim 14, wherein said maximum beam height is being 370% to 380% of said maximum central beam height.
16. The running gear frame according to any one of claims 1 to 15, wherein,
 - said primary suspension interface is configured to take a total resultant support force acting on said free end section when said frame body is supported on said associated wheel unit;
 - said primary suspension interface being configured such that said total resultant support force is inclined with respect to said longitudinal direction and/or inclined with respect to said height direction.
17. The running gear frame according to claim 16, wherein said total resultant support force is being inclined with respect to said height direction by a primary suspension angle.
18. The running gear frame according to claim 17, wherein said primary suspension angle is ranging from 20° to 80°.
19. The running gear frame according to claim 18, wherein said primary suspension angle is ranging from 30° to 70°.
20. The running gear frame according to claim 19, wherein said primary suspension angle is ranging from 40° to 50°.
21. The running gear frame according to any one of claims 16 to 20, wherein,
 - said primary suspension interface defines a main interface plane;

- said main interface plane being configured to take at least a major fraction of said resultant support force;
 - said main interface plane being inclined with respect to said longitudinal direction and/or inclined with respect to said height direction.
22. The running gear frame according to claim 21, wherein said main interface plane is being inclined with respect to said height direction by a main interface plane angle.
23. The running gear frame according to claim 22, wherein said main interface plane angle is ranging from 20° to 80°.
24. The running gear frame according to claim 23, wherein said main interface plane angle is ranging from 30° to 70°.
25. The running gear frame according to claim 24, wherein said main interface plane angle is ranging from 40° to 50°.
26. The running gear frame according to any one of claims 22 to 25, wherein said main interface plane is being substantially parallel with respect to said transverse direction.
27. The running gear frame according to any one of claims 16 to 26, wherein,
- said pivot interface section, in said longitudinal direction, is arranged to be at least partially retracted behind a center of said primary suspension interface;
 - a center of a forward primary suspension interface and a center of a rearward primary suspension interface of one of said longitudinal beams, in said longitudinal direction, defining a primary suspension interface center distance;
 - the forward pivot interface section being associated to said forward primary suspension interface and defining the forward pivot axis for the forward pivot arm;
 - the rearward pivot interface section being associated to said rearward primary suspension interface and defining the rearward pivot axis for the rearward pivot arm;
 - said forward pivot axis and said rearward pivot axis, in said longitudinal direction, defining the pivot axis distance.
28. The running gear frame according to claim 27, wherein said pivot axis distance is being 60% to 105% of said primary suspension interface center distance.
29. The running gear frame according to claim 28, wherein said pivot axis distance is being 70% to 95% of said primary suspension interface center distance.

30. The running gear frame according to claim 29, wherein said pivot axis distance is being 80% to 85% of said primary suspension interface center distance.
31. The running gear frame according to any one of claims 16 to 30, wherein,
- said primary suspension interface is configured as an interface for a single primary suspension device.
32. The running gear frame according to claim 31, wherein said primary suspension device is being formed by a single primary suspension unit.
33. The running gear frame according to claim 32, wherein said primary suspension unit is being formed of a single primary suspension spring.
34. The running gear frame according to claim 33, wherein said single primary suspension spring is a rubber-metal-spring unit.
35. The running gear frame according to any one of claims 1 to 34, wherein,
- said transverse beam unit comprises at least one transverse beam;
 - said at least one transverse beam, in a sectional plane parallel to said longitudinal direction and said height direction, defining a substantially C-shaped cross section.
36. The running gear frame according to claim 35, wherein said substantially C-shaped cross section is being arranged such that, in said longitudinal direction, it is open towards a free end of said frame body.
37. The running gear frame according to claim 36, wherein said substantially C-shaped cross section is being arranged such that, in said longitudinal direction, it is open towards the free end of said frame body substantially closed towards a center of said frame body.
38. The running gear frame according to claim 37, wherein, said substantially C-shaped cross section is extending, in said transverse direction, over a transversally central section of said transverse beam unit.
39. The running gear frame according to claim 38, wherein said substantially C-shaped cross section is extending, in said transverse direction, over a transverse dimension.
40. The running gear frame according to claim 39, wherein said transverse dimension is being at least 50% of a transverse distance between longitudinal center lines of said longitudinal beams in the area of said transverse beam unit.

41. The running gear frame according to claim 40, wherein said transverse dimension is being at least 70% of the transverse distance between the longitudinal center lines of said longitudinal beams in the area of said transverse beam unit.
42. The running gear frame according to claim 41, wherein said transverse dimension is being 80% to 95% of the transverse distance between the longitudinal center lines of said longitudinal beams in the area of said transverse beam unit.
43. The running gear frame according to any one of claims 35-42, wherein,
- said at least one transverse beam is a first transverse beam and said transverse beam unit comprises a second transverse beam.
44. The running gear frame according to claim 43, wherein said first transverse beam and said second transverse beam are being substantially symmetric with respect to a plane of symmetry parallel to said transverse direction and said height direction.
45. The running gear frame according to claim 44, wherein said first transverse beam and said second transverse beam are being separated, in said longitudinal direction, by a gap having a longitudinal gap dimension.
46. The running gear frame according to claim 45, wherein said longitudinal gap dimension is being 70% to 120% of a minimum longitudinal dimension of one of said transverse beams in said longitudinal direction.
47. The running gear frame according to claim 46, wherein said longitudinal gap dimension is being 85% to 110% of the minimum longitudinal dimension of the one of said transverse beams in said longitudinal direction.
48. The running gear frame according to claim 47, wherein said longitudinal gap dimension is being 95% to 105% of the minimum longitudinal dimension of the one of said transverse beams in said longitudinal direction.
49. The running gear frame according to claim 48, wherein said first transverse beam and said second transverse beam are each defining a transverse beam center line, at least one of said transverse beam center lines, at least section wise, having a generally curved or polygonal shape in a first plane parallel to said longitudinal direction and said transverse direction and/or a second plane parallel to said transverse direction and said height direction.

51. The running gear frame according to claim 50, wherein said locally waisted unit is a centrally waisted unit.
52. The running gear frame according to claim 50, wherein said transverse beam unit is having a waisted section defining a minimum longitudinal dimension of said transverse beam unit in said longitudinal direction.
53. The running gear frame according to claim 52, wherein said minimum longitudinal dimension of said transverse beam unit is being 40% to 90% of a maximum longitudinal dimension of said transverse beam unit in said longitudinal direction.
54. The running gear frame according to claim 53, wherein said minimum longitudinal dimension of said transverse beam unit is being 50% to 80% of the maximum longitudinal dimension of said transverse beam unit in said longitudinal direction.
55. The running gear frame according to claim 54, wherein said minimum longitudinal dimension of said transverse beam unit is being 60% to 70% of the maximum longitudinal dimension of said transverse beam unit in said longitudinal direction.
56. The running gear frame according to any one of claims 53 to 55, wherein said maximum longitudinal dimension is being defined at a junction of said transverse beam unit and one of said longitudinal beams.
57. The running gear frame according to any one of claims 1 to 56, wherein,
- said free end section, in a section facing away from said primary spring interface, forms a stop interface for a stop device.
58. The running gear frame according to claim 57, wherein said stop device is being at least one of: a rotational stop device and longitudinal stop device.
59. The running gear frame according to claim 57, wherein said stop device is being adapted to form a traction link between said frame body and a component supported on said frame body.
60. The running gear frame according to claim 59, wherein said component is a bolster or a wagon body.
61. A rail vehicle unit, comprising
- a first running gear unit according to any one of claims 1 to 60 supported on two wheel units via primary spring units and pivot arms connected to a frame body of said first running gear unit to form a first running gear;

- a rail vehicle component.
62. The rail vehicle unit of claim 61, wherein said rail vehicle component is being supported on said frame body.
63. The rail vehicle unit of claim 62, wherein said rail vehicle component is being a bolster or a wagon body.
64. The rail vehicle unit of claim 63, further comprising a second running gear unit according to any one of claims 1 to 60 supported on two wheel units via primary spring units and pivot arms connected to a frame body of said second running gear unit to form a second running gear.
65. The rail vehicle unit of claim 64, wherein said first running gear is being a driven running gear comprising a drive unit.
66. The rail vehicle unit of claim 64, wherein said second running gear is being a non-driven running gear having a no drive unit.
67. The rail vehicle unit of claim 64, wherein at least said frame body of said first running gear frame and said frame body of said second running gear frame are being substantially identical.
68. A method for producing a running gear frame according to any one of claims 1 to 60, wherein said frame body is cast in a single step.
69. The method of claim 68, wherein said frame body is cast in the single step in an automated casting process.

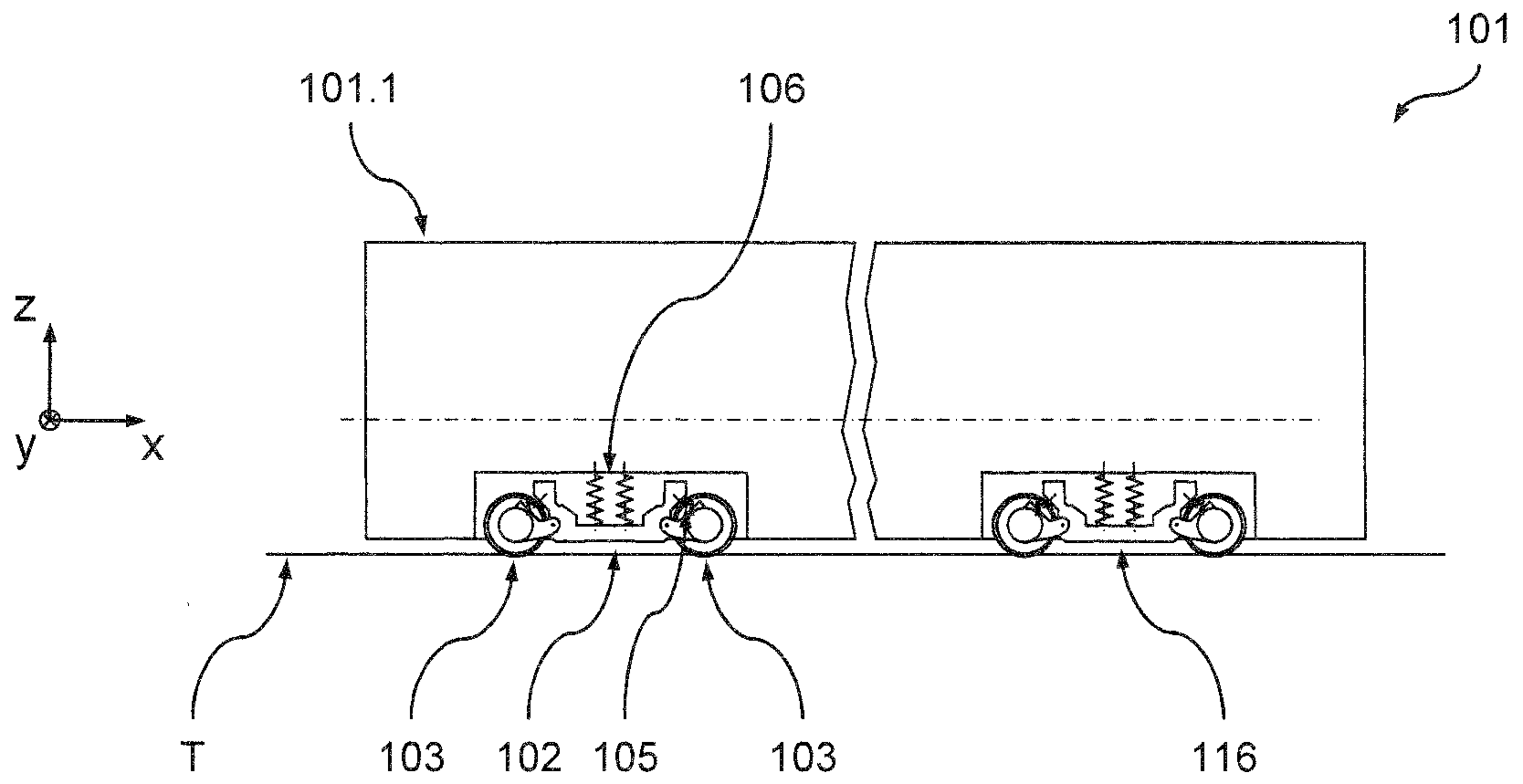

Fig. 1

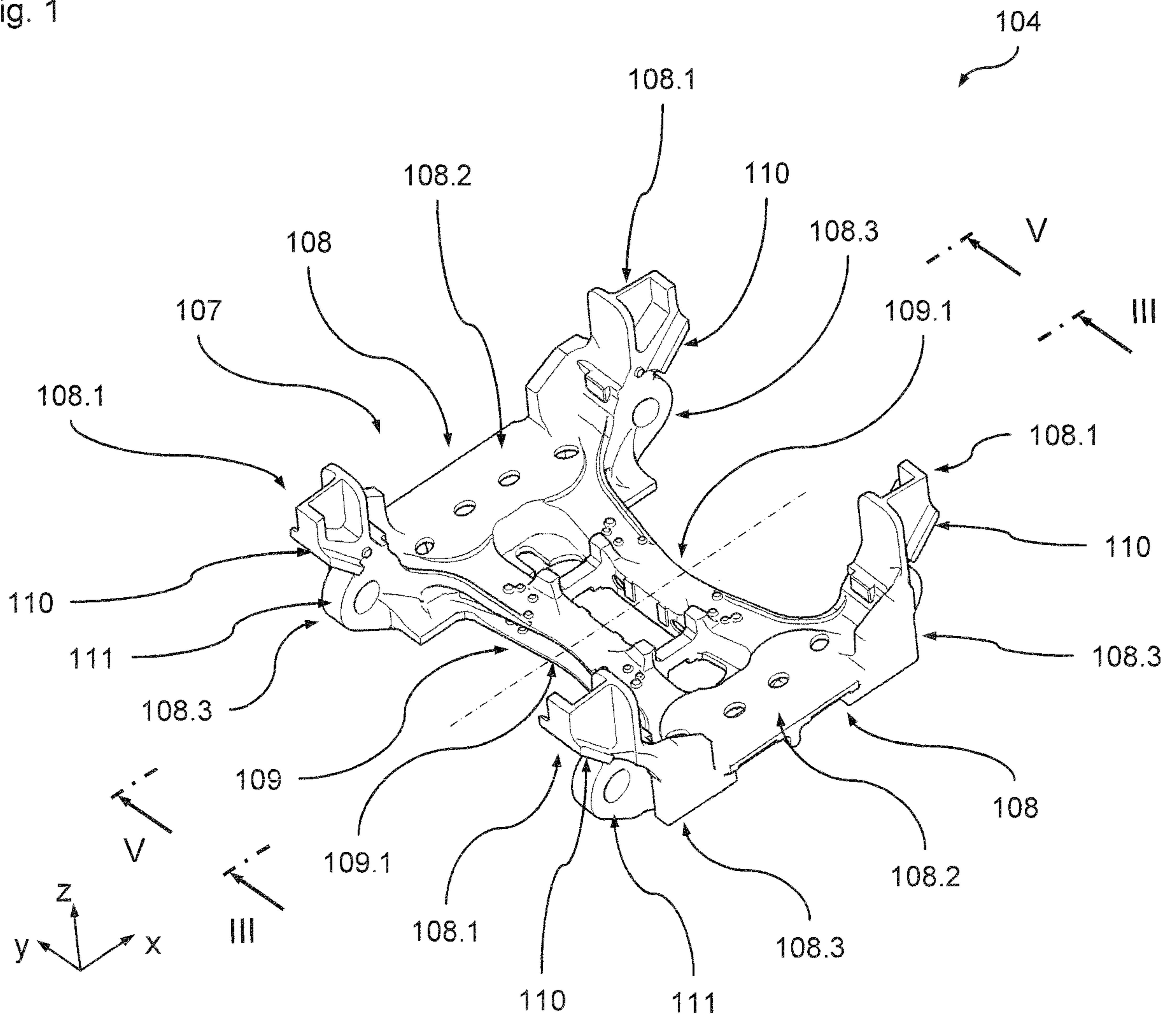

Fig. 2

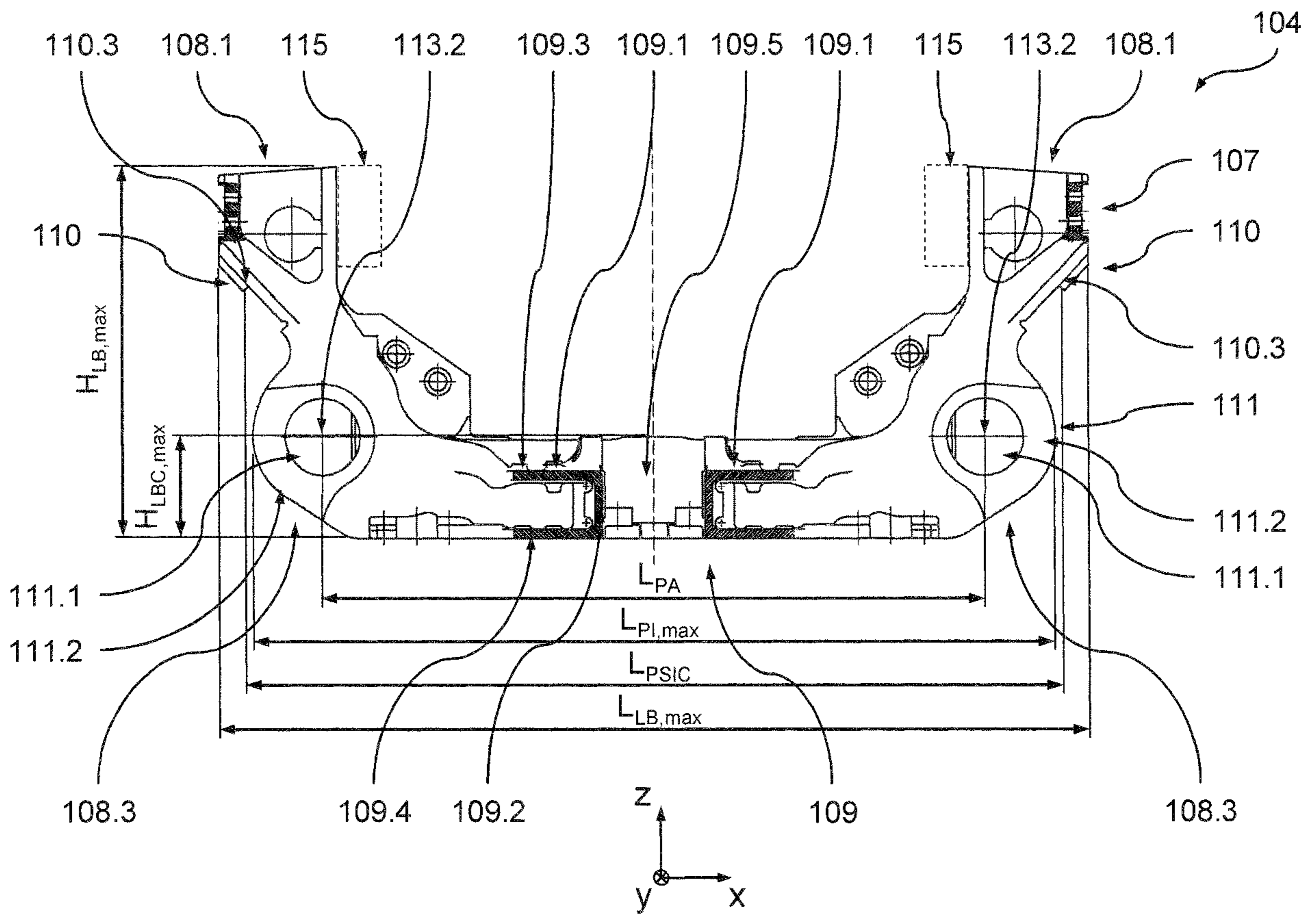

Fig. 3

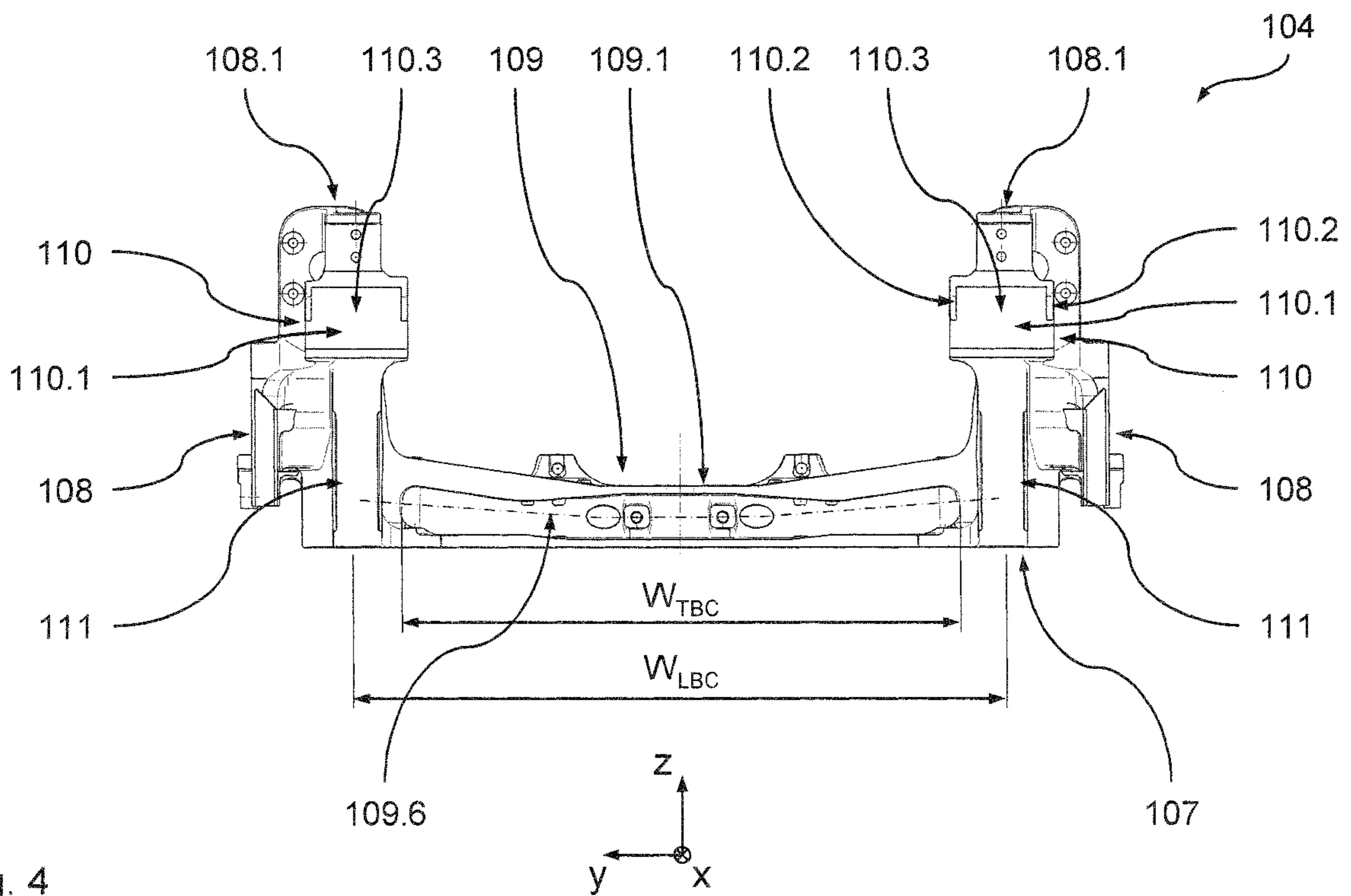

Fig. 4

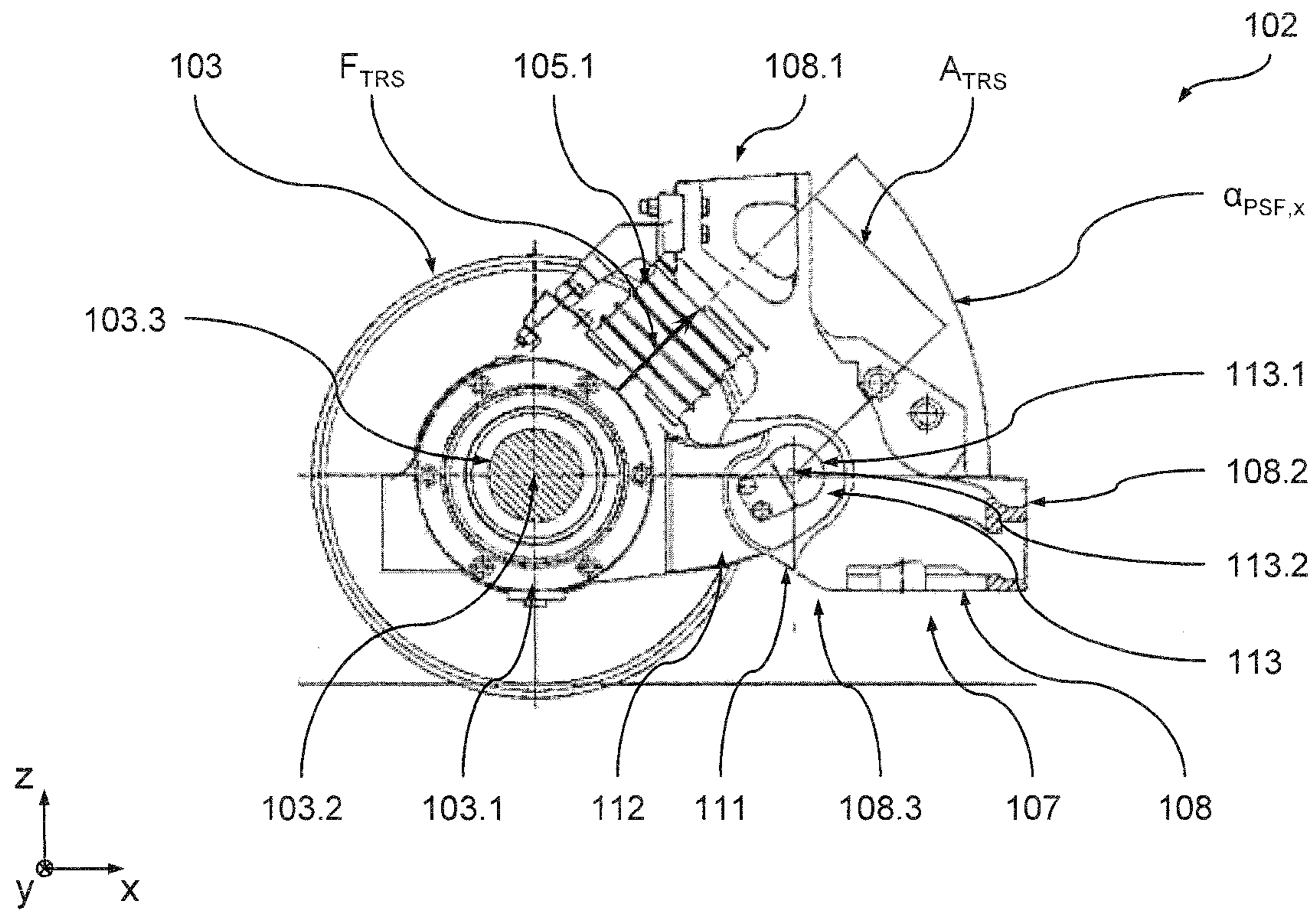

Fig. 5

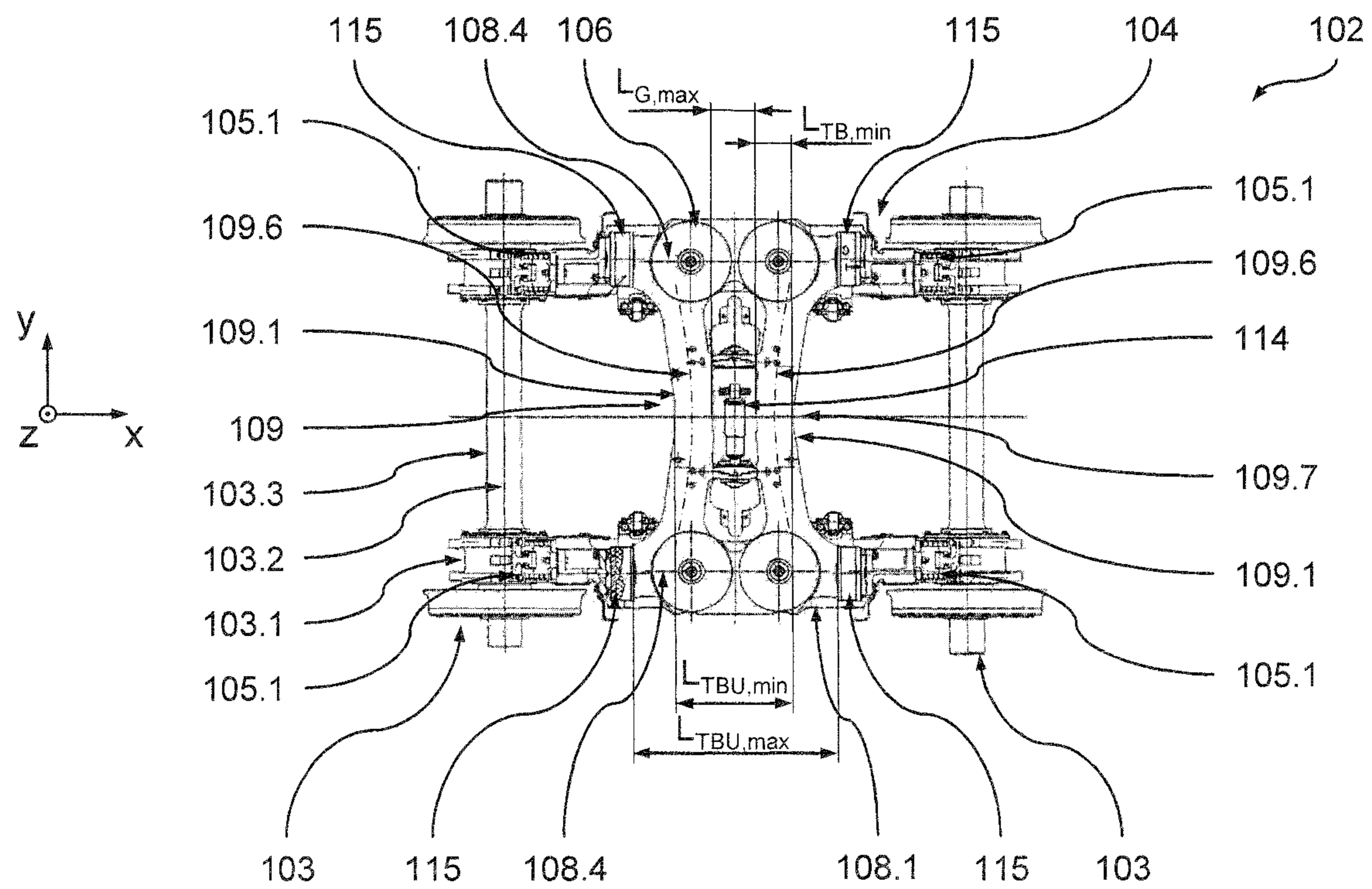

Fig. 6

