

< >

30... 31...
 32... 33...
 34... 35...
 37... 50...
 51... 1 52... 2
 310... 311...
 320... 323... 1
 324a,324b... 2 330...
 333... 1 334a,334b... 2

가

(secondary battery)

3.6V

3

가

(lithium polymer battery)

가

(pouched type)

가 가

1

(10)

(110)

(10)

(11)

(11)가

(111)

(11)

(stack type)

(jelly-roll type)

(11)

(12)

(13)

(12)(13)

(12)(13)

(110)

(112)

(12)(13)

)

(112)

(110)

(12)(13)

(14)(15)가

(110)

(111)가

(111) 가

(110)
(112)

(11)가

2 1 -

(110)

(120) ,
(130)

(120)

7)

(120)(130)

(11)가

(111)

(16),

(18),

(1

(120) 가
(130) 가

1 2

(121)(122)
(131)(132)

1 2
가

(121 132)
(110)

(111)

(11)가

1 2
1 2

(121 132)
(121 132)

(110)
가

(10)

가

1 2
110)

(110) (11)
(121 132)

(11)가

1 2 (11) 가
(121 132) (110)

1 2

(121 132)
(W₂)

가 , ,

(W₁)

가

1 2
(110)

(121 132)

(110)

가

가 , 가 ;

1

;

1

2

가,

가,

3

1

(30)

(30)

(31)

(31)

(310)

(31)

(32)

(33)

(32)(33)

(34)

(31)

(32),

(34),

(33)

(32),

(34),

(33)

(31)

(32)

(35)

(36)가

(32)

(35)

(33)

(37)

(38)가

(32)

(37)

(34)

(32)

(33)

(34)

(34)

(32)(33)

(32)(33)

(310)

(320)

(320)(330)

(320)

가 가

(330)

(310)

(320)(330)

(320)(330)

(31)가

(331)

(330)

(331)

(331) 가

(332)

(320)

(332)

(322)(332)

(31)가

(331)

(322)

(322)(332)

(35)(36)

1

(323)(3

33)

1

(323)(33)

(310)

2

2

(324a)(324b)(334a)(334b)

2

(324a

334b)

(310)

가

(320)(330)
(320)(330)

(310) (310) (311) (322)(332)

4 3 (30) 5 4 -

4 5 (310) (31)가 (31)가 (331)
) 가 (324a)(324b)(334a)(334b) 1 (323)(333) 가 2

1 (323) 1 (333) (32)(33)
(35)(37) (36)(38) (35)(37) 1
(323)(333)

1 (323)(333) (310) 2
(324a)(324b)(334a)(334b) (331) (310) (311)
2 (324a 334b) (310) (311) (35)(37)

310 (30) (W3) (31)가 (331) (((310) (310) (311) 2 (324a 334b)

(30) (50)가 2 (324a (324a (310)
334b) (311) 가

(50) (31)가 (331) (310) (311)
2 (324a 334b)

(50) (310) 2 (324a)(334a)
b)(334b) 1 (51) 2 (310) (310) 2 (324

1 2 (51)(52) (310) (311) 2 (324a
334b) (Polyethylene tereph thalate, PET) (51)(52)

가 1 2 (51)(52) 가 가 20 30
가 1 2 (51)(52)

(32), (34), (33) (30) (320)(330) (331)
(35)(37) (310) 1 (323)(333) (31) (331) 가
가 (310) 2 (324a 334b) (323)(333)

, 2 (324a 334b) (331) (310) (311)

(310) (311) 2 (324a 334b) 1 2
(51)(52) , 1 2 (51)(52) (310)
2 (324a 334b) , 1 2
(51)(52) (310) 2 (324a 334b)

(310) (W3) (331) (310) (310)
(311) (324a 334b) (324a 334b) , (310) (311)
2) 2 (324a 334b) 가 , 1 2 (51)(5)

6 2 (60)

(610) (61)가 (61)가 (631) 가
1 (623)(633) (65)(67) (65)(6)
7) (66)(67)가

1 (623)(633) 2 (624)(634)
(610) 2 (624)(634) 1
가 (610) (65)(67)

(610) 2 (624)(634) (610)
(600)가 2 (624)(634) (610)
, 20 30 (600) PET

, (610) 2 (624)(634)

, 가

가 .

가 .

가

가가

(57)

1.

, ,

;

;

가 , 가 ;

1 ; .

1 2. ,

2 1 .

1 3. ,

2 4. 3 ,

2 5. 3 ,

1 6. ,

6 7. ,

PET

1 8. ,

20 30 .

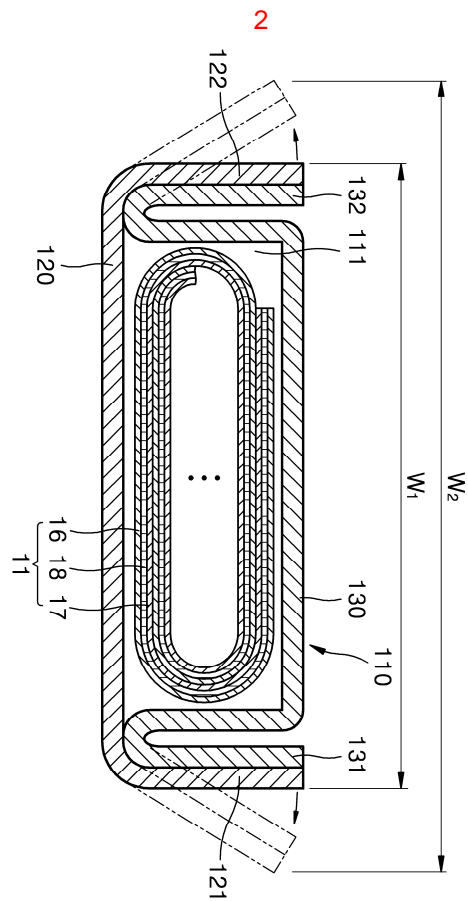
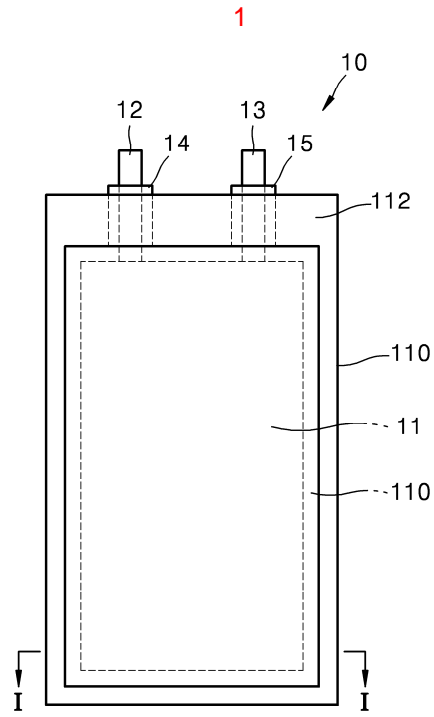

3

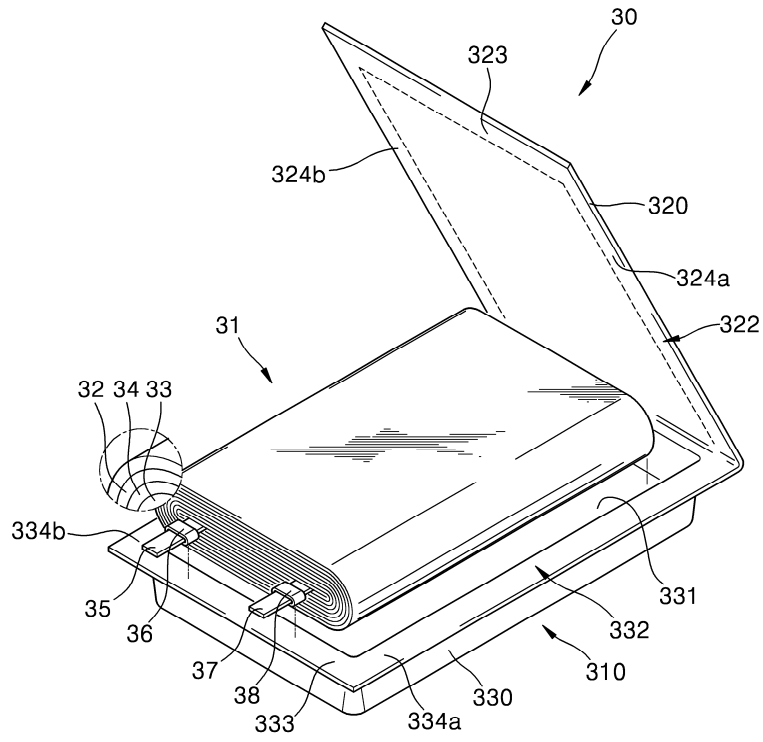

4

