



US 20060077375A1

(19) **United States**

(12) **Patent Application Publication**  
**Vermillion et al.**

(10) **Pub. No.: US 2006/0077375 A1**

(43) **Pub. Date: Apr. 13, 2006**

(54) **METHOD, DEVICE, AND COMPUTER PROGRAM FOR DETERMINING A RANGE TO A TARGET**

**Publication Classification**

(51) **Int. Cl.**  
*G01C 3/08* (2006.01)  
*G01S 13/00* (2006.01)  
(52) **U.S. Cl.** ..... **356/4.01; 356/5.01**

(76) Inventors: **Jordan Vermillion**, Overland Park, KS (US); **Bill Cross**, Overland Park, KS (US)

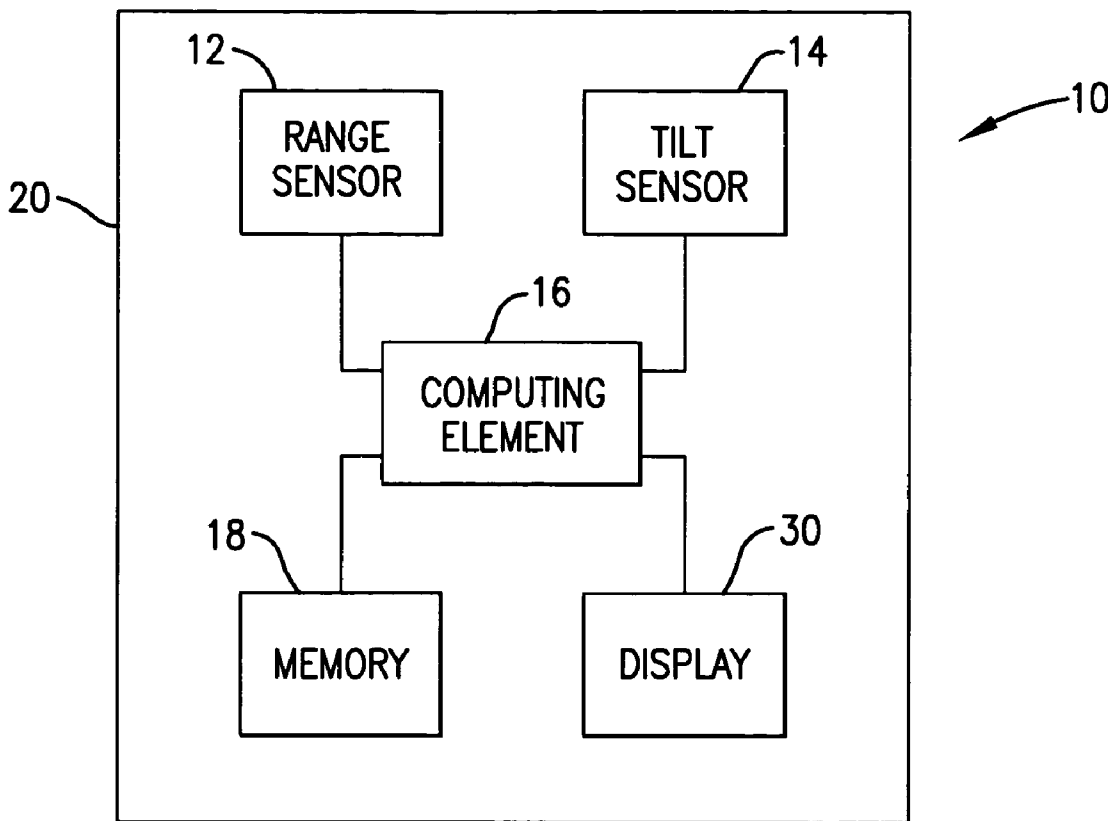
(57) **ABSTRACT**

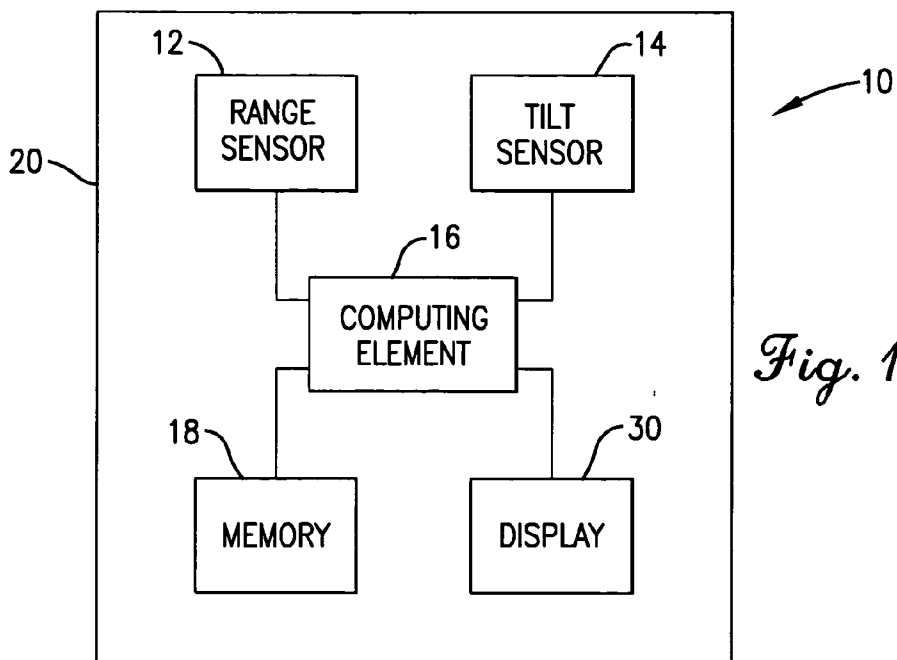
A method, device, and computer program for determining range to a target is disclosed. Specifically, the invention provides a method, device and computer program for determining a second range to a target based on a first range to the target and an angle to the target such that the parabolic trajectory of a projectile is accounted for in determining the second range. The device generally includes a range sensor for determining a first range to a target, a tilt sensor for determining an angle to the target, and a computing element for determining a second range to the target based on the first range and the determined angle.

Correspondence Address:  
**HOVEY WILLIAMS LLP**  
**2405 GRAND BLVD., SUITE 400**  
**KANSAS CITY, MO 64108 (US)**

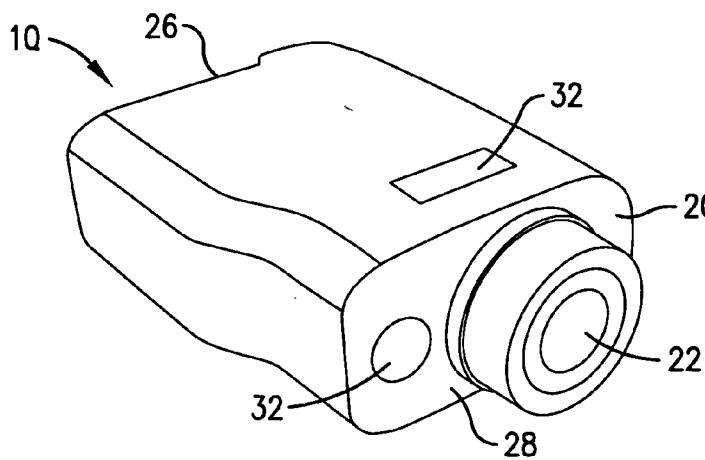
(21) Appl. No.: **10/964,206**

(22) Filed: **Oct. 13, 2004**

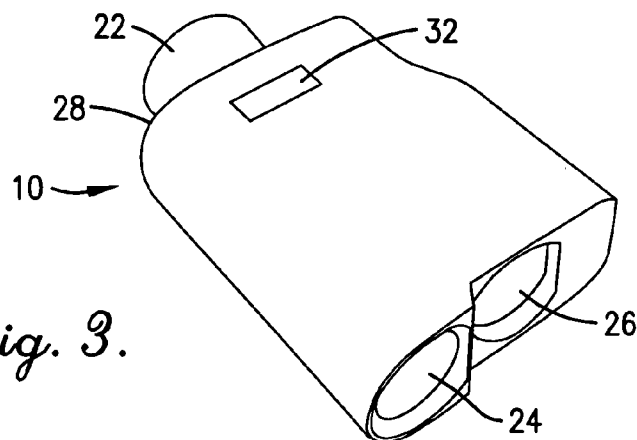




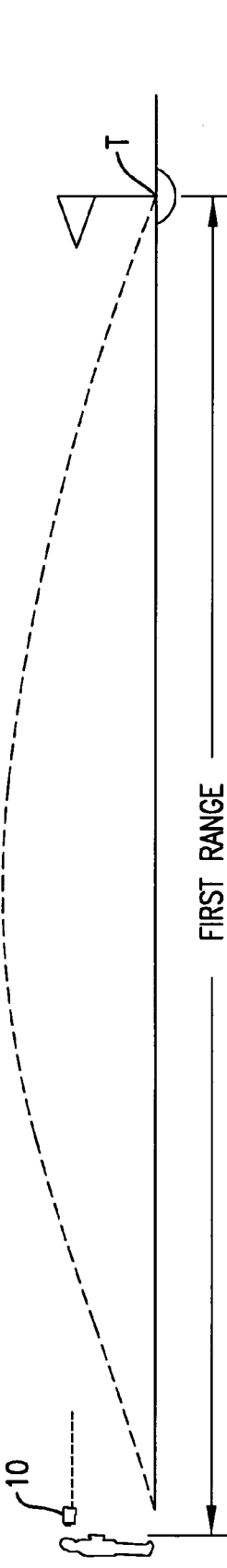
*Fig. 1.*



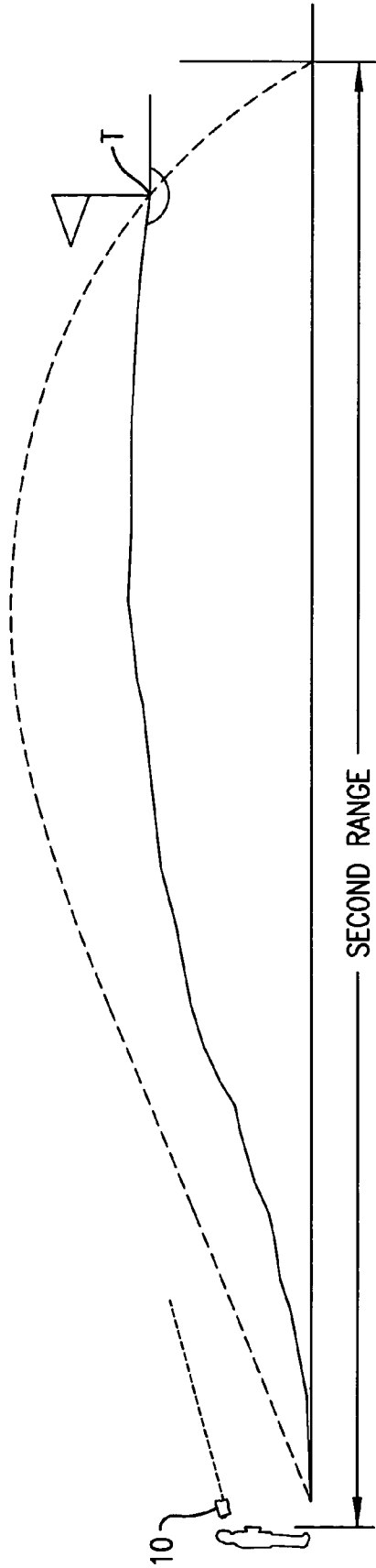
*Fig. 2.*



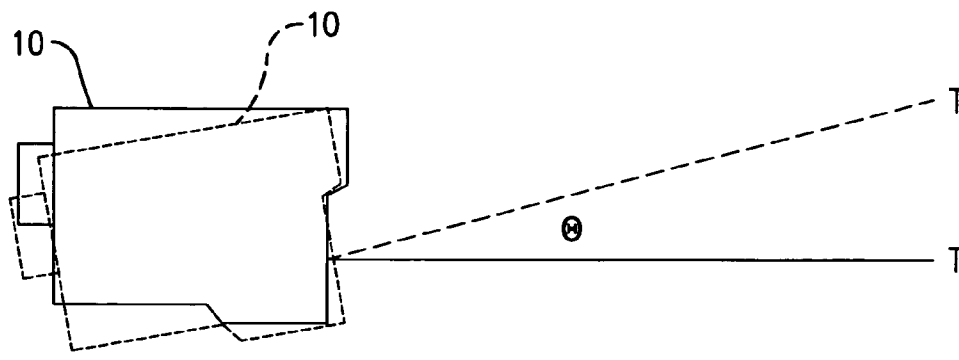
*Fig. 3.*



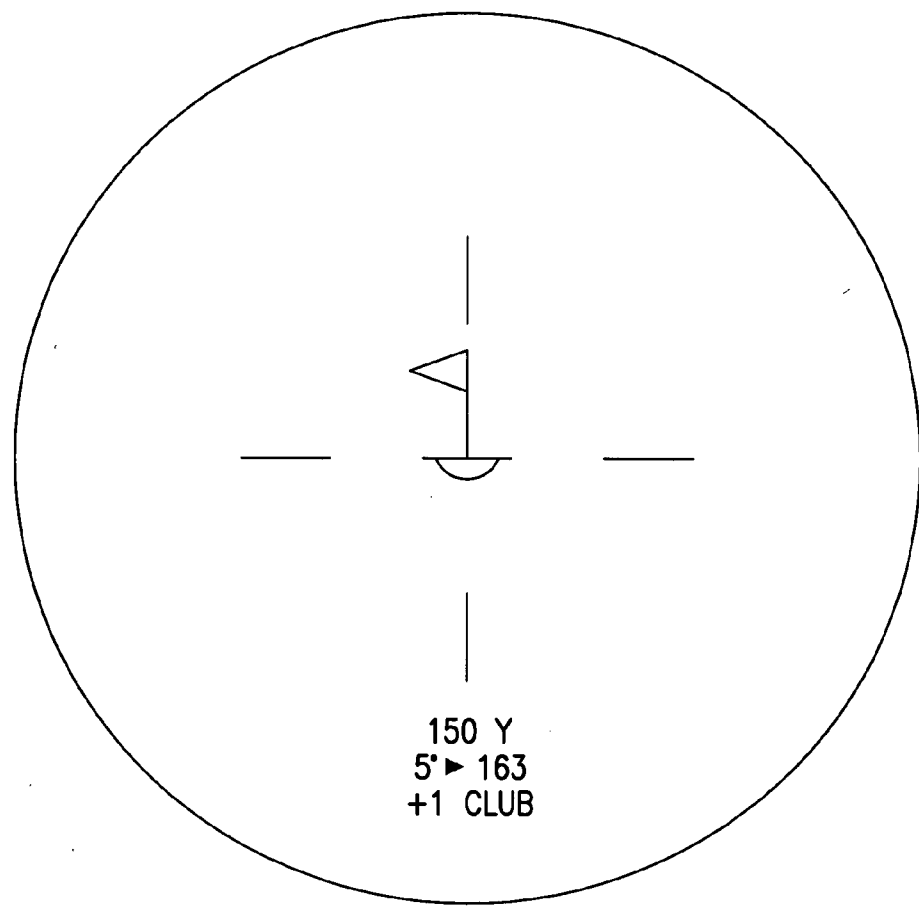
*Fig. 4.*



*Fig. 4a.*



*Fig. 5.*



*Fig. 8.*

Angle $\theta$	Multiplier
1	0.0175
2	0.035
3	0.0525
4	0.07
5	0.0875
6	0.105
7	0.1225
8	0.14
9	0.1575
10	0.175
11	0.1925
12	0.21
13	0.2275
14	0.25
15	0.27
16	0.29
17	0.305
18	0.325
19	0.345
20	0.3625

*Fig. 6.*

First Range	Angle	Multiplier	Factor	Second Range
100	3	0.0525	0.0394	104
150	5	0.0875	0.0875	163
200	7	0.1225	0.1225	225
124	7	0.1225	0.092	135
218	4	0.07	0.07	233
241	6	0.105	0.105	266
104	-2	-0.035	-0.263	101
148	-6	-0.105	-0.105	132

*Fig. 7.*

## METHOD, DEVICE, AND COMPUTER PROGRAM FOR DETERMINING A RANGE TO A TARGET

### BACKGROUND OF THE INVENTION

#### [0001] 1. Field of the Invention

[0002] The present invention relates to a method, device, and computer program for determining a range to a target. More particularly, the invention relates to a method, device, and computer program for determining a second range to a target based on a first range and an angle to the target such that the parabolic trajectory of a projectile is accounted for in determining the second range.

#### [0003] 2. Description of the Related Art

[0004] It is often desirable to determine accurate ranges to targets in various situations. For example, golfers utilize a range to a target, such as a range to a green or a pin positioned on the green, in determining club selection. Conventional devices have been developed to determine ranges to targets. However, these conventional devices determine ranges which only represent a straight-line distance to a target and which fail to account for the parabolic trajectory of projectiles, such as a golf ball, intended for the target. As a result, these conventional devices generate inaccurate results if a target is positioned above or below the device. For instance, if a target is positioned above a device, a projectile originating at the device, such as a struck golf ball, must be struck to travel a greater distance to reach the target than if the target was not positioned above the device due to the parabolic trajectory of the golf ball. Similarly, if a target is positioned below a device, a projectile originating at the device must be struck to travel a lesser distance to intersect the target than if the target was not positioned below the device. Conventional devices are unable to account for this increase or decrease in distance to a target caused by the trajectory of the projectile and the angle to the target.

[0005] As individuals often determine ranges to targets while outdoors on terrains of varying slopes, such as a golfer on a golf course, the inaccurate results generated by conventional range determining devices substantially inhibit the use of the devices and negate many beneficial aspects of the devices. For instance, a golfer is unlikely to utilize a range finding device which provides inaccurate yardage measurements over sloping terrain and thus is forced to use multiple devices to determine a single accurate range or manually estimate or guess at the correct yardage based on the determined range. Such use of estimations and multiple devices results in undesirable inconvenience and inaccuracy.

### SUMMARY OF THE INVENTION

[0006] The present invention solves the above-described problems and provides a distinct advance in the art of determining ranges to targets or other objects. More particularly, the invention provides a method, device, and computer program for determining a second range to a target based on a first range and an angle to the target such that the parabolic trajectory of a projectile is accounted for in determining the second range.

[0007] In one embodiment, the present invention concerns a device for determining a range to a target. The device includes a range sensor for determining a first range to the

target, a tilt sensor for determining an angle to the target, and a computing element for determining a second range to the target based on the first range and the determined angle.

[0008] In another embodiment, the device includes a laser range sensor for determining a first range to the target, a tilt sensor for determining an angle to the target relative to the device based on the orientation of the device, a computing element for determining a second range to the target by adjusting the first range by a factor corresponding to the determined angle, and a display for indicating relevant information including the first range and/or the second range.

[0009] In a further embodiment, the present invention concerns a computer program comprising a combination of code segments stored in a computer-readable memory and executable by a computing element. The computer program includes a code segment operable to determine a first range to a target based on a first input, a code segment operable to determine an angle to the target relative to the device based on a second input, and a code segment operable to determine a second range to the target by adjusting the first range by a factor corresponding to the determined angle.

[0010] In a still further embodiment, the present invention concerns a method for utilizing a portable electronic device to determine a range to a target. The method includes determining a first range from the device to the target with a laser range sensor, determining an angle to the target relative to the device with a tilt sensor, determining a second range to the target by adjusting the first range by a factor corresponding to the determined angle, and indicating the first range, the angle, and/or the second range.

[0011] Other aspects and advantages of the present invention will be apparent from the following detailed description of the preferred embodiments and the accompanying drawing figures.

### BRIEF DESCRIPTION OF THE DRAWING FIGURES

[0012] A preferred embodiment of the present invention is described in detail below with reference to the attached drawing figures, wherein:

[0013] **FIG. 1** is a block diagram showing various components of a device constructed in accordance with a preferred embodiment of the present invention;

[0014] **FIG. 2** is a rear isometric view of the device of **FIG. 1**;

[0015] **FIG. 3** is a front isometric view of the device of **FIGS. 1 and 2**;

[0016] **FIG. 4** is a diagram illustrating a first range to a target and a trajectory to the first target;

[0017] **FIG. 4a** is a diagram illustrating a second range and trajectory to the target of **FIG. 4** when the target is elevated;

[0018] **FIG. 5** is a diagram illustrating an angle to an elevated target relative to the device;

[0019] **FIG. 6** is a table presenting examples of the multipliers utilized by the present invention to calculate factors;

[0020] FIG. 7 is a table presenting examples of the second ranges determined by utilizing some of the factors calculated with the multipliers presented in FIG. 6; and

[0021] FIG. 8 is a schematic view of a target observed while looking through the device which indicates the first range, the determined angle, the second range, and a recommended change in club length.

[0022] The drawing figures do not limit the present invention to the specific embodiments disclosed and described herein. The drawings are not necessarily to scale, emphasis instead being placed upon clearly illustrating the principles of the invention.

#### DETAILED DESCRIPTION OF THE PREFERRED EMBODIMENTS

[0023] Turning now to the drawing figures, and particularly FIGS. 1-3, a device 10 is shown constructed in accordance with a preferred embodiment of the present invention. The device 10 broadly includes: a range sensor 12 for determining a first range to a target T; a tilt sensor 14 for determining an angle  $\theta$  to the target T; a computing element 16 coupled with the range sensor 12 and tilt sensor 14 for determining a second range to the target T based on the first range and the determined angle  $\theta$ ; a memory 18 for storing data such as a computer program to control the functionality of the device 10; and a portable handheld housing 20 for housing the range sensor 12, the tilt sensor 14, the computing element 16, the memory 18, and other components described below.

[0024] The computer program controls input and operation of the device 10. The computer program includes at least one code segment stored in or on a computer-readable medium residing on or accessible by the device 10 for instructing the range sensor 12, tilt sensor 14, computing element 16, and any other related components to operate in the manner described herein. The computer program is preferably stored within the memory 18 and comprises an ordered listing of executable instructions for implementing logical functions in the device 10. However, the computer program may comprise programs and methods for implementing functions in the device 10 which are not an ordered listing, such as hard-wired electronic components, programmable logic such as field-programmable gate arrays (FPGAs), application specific integrated circuits, or other similar or conventional methods for controlling the operation of electrical or other computing devices.

[0025] Similarly, the computer program may be embodied in any computer-readable medium for use by or in connection with an instruction execution system, apparatus, or device, such as a computer-based system, processor-containing system, or other system that can fetch the instructions from the instruction execution system, apparatus, or device, and execute the instructions. The computer-readable medium may even be paper or another suitable medium upon which the program is printed, as the program can be electronically captured, via for instance, optical scanning of the paper or other medium, then compiled, interpreted, or otherwise processed in a suitable manner, if necessary, and then stored in a computer memory.

[0026] The device 10 and computer program illustrated and described herein are merely examples of a device and a

program that may be used to implement the present invention and may be replaced with other devices and programs without departing from the scope of the present invention.

[0027] Referring to FIGS. 1-5, the range sensor 14 is operable to determine the first range to the target T from the device 10. The range sensor 14 may be any conventional sensor or device for determining range. The first range preferably represents a length of an imaginary line drawn between the device 20 and the target T, as shown in FIGS. 4 and 5, such as the number of feet, meters, yards, miles, etc. directly between the device 10 and the target T. The first range may also represent other units of measurements, such as an estimated golf club length required to reach the target T.

[0028] Preferably, the range sensor 14 is a laser range sensor which determines the first range to the target by directing a laser beam at the target T, detecting a reflection of the laser beam, measuring the time required for the laser beam to reach the target and return to the range sensor 14, and calculating the first range of the target T from the range sensor 14 based on the measured time. Thus, the range sensor 14 may include an emitter and a detector to emit the laser beam and then detect the reflection of the laser beam in a generally conventional manner.

[0029] The range sensor 14 is operable to determine a range to a target even when objects, such as trees, people, vehicles, foliage, etc. are positioned between the device and the target. As a result, the range sensor 14 may determine the first range to the target T in a variety of situations, including on golf courses and other outdoor situations where various trees and/or other foliage may obstruct a direct view of the target T.

[0030] The range sensor 14 may also include memory and processing capabilities separate from the computing element 16 and memory 18, such that the range sensor is operable to determine the range to the target T without the assistance of additional components. However, the range sensor 14 may rely upon the capabilities provided by the computing element 16 and memory 18 to specifically calculate and determine the first range. The range sensor 14 may alternatively or additionally include other range sensing components, such as conventional optical, radio, sonar, or visual range sensing devices to determine the first range in a substantially conventional manner.

[0031] The range sensor 14 may be specifically configured for use with a specific type of target. For instance, the target T may be a portion of a golf course, such as a green or a pin positioned on the green, as described below in detail, and the range sensor 14 may be specifically configured to more accurately determine the first range based on the characteristics of the desired and known target. For example, the range sensor 14 may emit a laser beam having a specific wavelength or intensity to reflect off the target T in an anticipated and desired manner due to the characteristics of the desired target, such as a colored pin or a reflective flag positioned on the pin. Thus, the accuracy of the determined first range may be increased by specifically configuring the range sensor 14 utilizing the anticipated and desired reflection characteristics of the known target T.

[0032] Referring to FIGS. 4, 4a, and 5, the tilt sensor is operable to determine the angle  $\theta$  to the target T from the

device **10** relative to the horizontal. Thus, if the device **10** and the target **T** are both positioned on a flat surface having no slope, the angle  $\theta$  would be zero. If the device **10** is positioned below the target **T**, as shown in **FIG. 4a**, the slope between the device **10** and the target **T** is positive, the angle  $\theta$  would be positive. Conversely, if the device **10** is positioned above the target **T**, such that the slope between the device **10** and the target **T** is negative, the angle  $\theta$  would be negative. It will be appreciated that the angle  $\theta$  is not dependent upon the specific contours of the ground or surface or surfaces between the device **10** and the target **T**, but rather the angle  $\theta$  is preferably determined based on the orientation of the device **10**, as described below.

[0033] The tilt sensor **14** preferably determines the angle  $\theta$  by sensing the orientation of the device **10** relative to the target **T** and the horizontal. The orientation of the device **10** changes based on the relative position of the target **T** to the device **10**, as a user of the device **10** aligns the device **10** with the target **T** and views the target **T** through an eyepiece **22** and an opposed lens **24**, as described in more detail below. Thus, the orientation of a device, specifically the tilt of the device **10** along its longitudinal axis relative to the horizontal, indicates if the target **T** is above or below the device **10**. For example, if the target **T** is above the device **10**, the user of the device **10** would tilt the device **10** such that a distal end **26** of the device **10** would be raised relative to a proximate end **28** of the device **10** and the horizontal. Similarly, if the target **T** is below the device **10**, the user of the device **10** would tilt the device **10** such that the distal end **26** of the device **10** would be lowered relative to the proximate end **28** of the device and the horizontal. The tilt sensor **14** preferably determines the angle  $\theta$  of the target to the device **10** based on the amount of tilt, that is the amount the proximate end **28** is raised or lowered relative to the distal end **26**, as described below.

[0034] The tilt sensor **14** may determine the tilt of the device, and thus the angle  $\theta$ , through various orientation determining means. For instance, the tilt sensor **14** may utilize one or more single-axis or multiple-axis magnetic tilt sensors to detect the strength of a magnetic field around the device **10** or tilt sensor **14** and then determine the tilt of the device **10** and the angle  $\theta$  accordingly. The tilt sensor **14** may determine the tilt of the device using other or additional conventional orientation determine means, including mechanical means, chemical means, gyroscopic means, and/or electronic means, such as a resistive potentiometer. Preferably, the tilt sensor **14** is an electronic inclinometer, such as a clinometer, operable to determine both the incline and decline of the device **10** such that the angle  $\theta$  may be determined based on the amount of incline or decline. Thus, as the device **10** is aligned with the target **T** by the user, the device **10** may be tilted such that its proximate end **28** is higher or lower than the distal end **26**, and the tilt sensor **16** will detect the amount of tilt which is indicative of the angle  $\theta$ .

[0035] The computing element **16** may be a conventional microprocessor, microcontroller, or other electrical element or combination of elements, such as a single integrated circuit housed in a single package, multiple integrated circuits housed in single or multiple packages, or any other combination. Similarly, the computing element **16** may be any element which is operable to determine the second range from the first range and angle  $\theta$  as described below. Thus,

the computing element **16** is not limited to conventional microprocessor or microcontroller elements and may include any element which is operable to perform the functions described below.

[0036] The computing element **16** is coupled with the range sensor **14** and the tilt sensor **16** to determine the second range to the target **T** based on the first range and the determined angle  $\theta$ . The second range may be determined statically such that the second range is determined only at desired intervals or upon input by the user. Conversely, the second range may be dynamically determined such that the second range may be continuously updated as new first ranges or angles or provided. Thus, the second range may be accurately determined for moving targets, such as a hunted animal, as the change in the targets position is accounted for by the dynamic calculations.

[0037] The computing element **16** determines the second range to the target **T** by adjusting the first range by a factor corresponding to the angle  $\theta$ . The factor adjusts the first range to account for an estimated trajectory of a projectile. Thus, the second range preferably represents a distance the projectile must travel such that the estimated trajectory of the projectile generally intersects with the target **T**. In contrast, the first range represents the length of an imaginary line between the device **10** and the target **T**, which is a substantially straight line, as described above. As is known in the art, projectiles which are not self-propelled, such as bullets, golf balls, footballs, arrows, etc, move through air according to a generally parabolic (ballistic) curve due primarily to the effects of gravity and air drag. In situations where the angle  $\theta$  is zero, the parabolic movement of the projectile does not substantially affect the range calculation.

[0038] As shown in **FIG. 5**, in situations where the angle  $\theta$  is non-zero, such as when the target **T** is positioned above or below the device **10**, the parabolic movement of the projectile affects the range calculation, such that the projectile may have to travel a longer or shorter distance to reach the target **T**. The factor adjusts the first range to account for the longer or shorter distance the projectile must travel to reach the target **T** due to the angle  $\theta$  such that the second range is an accurate representation to the user of the flat-ground distance the projectile must travel to intersect the target **T**.

[0039] For example, a first range may be 100 yards which represents a straight line distance to a target, but with an angle of three degrees, a second range will be 104 yards, as determined by a calculation described below in detail. The second range of 104 yards represents the flat-ground range the projectile must travel such that its trajectory intersects the target at a position, as shown in **FIG. 4a**. Thus, the second range does not represent the actual straight-line distance to the target as it includes the larger or smaller distance the projectile must travel to intersect with target. For instance, if a user is 100 yards away from a target and desires to hit a golf ball at the target, the user would attempt to strike the golf ball 100 yards. On flat ground, no additional computation is needed and a golf ball struck to travel 100 yards will reach the target. However, on non-flat ground, such as when the angle  $\theta$  is three degrees for example, if the user strikes the golf ball to travel 100 yards as if on flat ground, the golf ball will fall short of the target due to the parabolic trajectory of the golf ball. In contrast, if the user

strikes the golf ball to reach the second range, 104 yards as if on flat ground for example, the golf ball will not fall short of the target as the trajectory of the golf ball will intersect with the target due to the increased distance accounted for by the second range.

[0040] Referring to FIG. 6, The factor may be determined utilizing conventional and well known algorithms or tables which account for the generally parabolic movement of a projectile through air based on a source angle of the projectile. Preferably, the factor is determined based on the angle  $\theta$  and a multiplier corresponding to the tangent of the angle  $\theta$ . The factors, and associated information, as described below, may be stored in the memory 18 to facilitate and expedite calculations by the computing element 16.

[0041] As shown in FIGS. 6 and 7, the memory 18 may include a list of angles, corresponding multipliers, and factors which are determined by scaling the multipliers based on the first range. For each angle, the corresponding multiplier is equal to the tangent of the angle and is also scaled based on the first range to determine the factor. The multiplier is scaled such that if the first range is less than or equal to 100 yards, the multiplier is reduced to one-half such that the factor equals one-half the multiplier. If the first range is between 100 yards and 140 yards, the factor will equal three-fourths of the multiplier. If the range is greater than 140 yards, the multiplier is not scaled such that the factor equals the multiplier. For negative angles, the multiplier is equal to the negative of the multiplier for the corresponding positive angle. Additionally, other scaling methods may be employed which adjust the multipliers or factors to account for the change in tangential value that occurs as a target approaches a reference point, such as when the target T is relatively near the device 10.

[0042] FIG. 7 presents an example table of first ranges and corresponding multipliers, factors, and second ranges. The second ranges may be determined from the factors utilizing any formula or calculation which accounts for the trajectory of a projectile. Preferably, the second ranges are determined from the first ranges and factors using the formula:

$$\text{SecondRange} = \text{FirstRange} + (\text{Factor} * \text{FirstRange})$$

[0043] Although the factors of FIGS. 6 and 7 are presented and described as scaled or unscaled multipliers which are multiplied by the first range and then added to the first range to determine the second range, the factors may be of any form or type which enables the trajectory of the projectile to be accounted for by the second range. For instance, various mathematical equivalents may be determined which are generally similar to the multipliers, factors, and formulas described above and which perform generally the same operation. Additionally, the factors may be any equation, algorithm, or estimation which are performed to adjust the first range for the trajectory of the projectile.

[0044] Additionally, the computing element 16 may determine the second range without utilizing factors, such as by utilizing the first range to estimate a full trajectory for the projectile and then modifying the estimated full trajectory based on the angle. However, it will be appreciated that utilizing factors expedites the determination of the second range as there is a generally finite number of useful angles and corresponding factors which may be calculated in

advance and stored in the memory 18 such that the computing element 16 is not required to perform extensive or resource-consuming calculations to determine each second range.

[0045] The factor may also be specifically determined for a desired projectile as projectiles having different shapes have different trajectories due to drag. For instance, the generally parabolic trajectory for a golf ball struck with a golf club is substantially different than the ballistic trajectory for a bullet fired from a firearm. Thus, it is desirable to select a factor which corresponds to the utilized projectile due to the varying shapes of various projectiles. For example, a golfer would utilize a factor which corresponds to a golf ball such that the trajectory of the golf ball is accurately accounted for to maximize the accuracy of the second range calculation. The device 10 may enable the user to select a desired projectile or desired projectile characteristic.

[0046] The factor and factors may be calculated by the computing element 16 upon request by the computer program, such as at any time when the second range needs to be calculated. Additionally or alternatively, the factors may be pre-stored in the memory 16 such that the factors do not need to be specifically calculated by the computing element 16 and instead may be determined by looking up the angle  $\theta$ , corresponding factor, and first range in the memory 16, such as within a look-up table. Upon looking up the factor, the computing element 16 may multiply the factor with the first range, as described above, to determine the second range. A comprehensive list of pre-stored angles, factors, first ranges, and second ranges may also be included in the memory 18 such that the computing element is not required to perform a multiplication operation for the second range calculation and instead the computing element 16 may simply lookup the second range based on the stored angle and first range utilizing one or more look-up tables or other storage methods.

[0047] The computing element 16 may additionally determine a desired change in golf club selection. As described above, a user may attempt to strike a golf ball shorter or longer based on the second range which includes the affects of the angle  $\theta$  and the parabolic trajectory of the golf ball. Users often control how far a golf ball will travel based on a club selection. For instance, a ball struck with a wedge may travel 100 yards, while a ball struck with a 9-iron may travel 115 yards. The user may provide specific club data and corresponding distance data and store such club data in the memory 18 to allow the computing element 16 to access the stored club data and determine a desired change in golf club selection based on the second range or the difference between the first range and the second range.

[0048] However, the computing element 16 may determine a desired change in golf club selection without requiring the user to input club data. For example, if the second range exceeds the first range by ten yards, the computing element 16 may determine that an extra club length is needed (e.g. an 7 iron versus a 8 iron), or if the second range exceeds the first range by thirty yards, the computing element 16 may determine that two extra club lengths are needed (e.g. a 6 iron versus a 8 iron). Similarly, the computing element 16 may compare the determined second range to the club data stored in the memory 16 and determine a desired change in club selection accordingly.

[0049] The memory 18 is coupled with the computing element 16 and is operable to store the computer program and data such as the factors described above. The memory 18 may be, for example, an electronic, magnetic, optical, electromagnetic, infrared, or semi-conductor system, apparatus, device, or propagation medium. More specific, although not inclusive, examples of the memory 18 include the following: an electrical connection having one or more wires, a portable computer diskette, a random access memory (RAM), a read-only memory (ROM), an erasable, programmable, read-only memory (EPROM or Flash memory), an optical fiber, a portable compact disc (CD), or a digital video disc (DVD). However, the memory 18 may be of any form operable to store the necessary computer program and data.

[0050] The memory 18 may be integral with the computing element 16, such that the memory 18 and the computing element 16 are stored within or on the same wafer, die, or package, or the memory 16 may be discrete with the computing element 16 such that the memory 18 and the computing element 16 are stored on different wafers, dies, or packages. Additionally, the memory 18 may be coupled with other components, such as the range sensor 12 and tilt sensor 14, to enable the other components to utilize the functionality provided by the memory 18. The memory 18 may also be accessible by other external devices, such as conventional computing devices, to enable data stored within the memory, such as the factors or the computer program, to be easily accessed or modified by the conventional computing device.

[0051] The device 10 also preferably includes a display 30 to indicate relevant information such as the first range, the angle  $\theta$ , the second range, the selected club, a reticle or other alignment element, the recommended club, and/or the recommended club change. The display 30 may be a conventional electronic display, such as a LED or LCD display. Preferably, the display 30 is viewed by looking through the eyepiece 22 such that a user may align the target T and simultaneously view relevant information, as shown in FIG. 8. For instance, the user may look through the eyepiece 22, align the target T, view the target T, and generally simultaneously view the display 30 to determine the first range, the angle  $\theta$ , the second range, and/or other relevant information. The generally simultaneous viewing of the target T and the relevant information enables the user to quickly and easily determine a plurality of ranges to various targets by moving the device 10 in an appropriate direction and dynamically viewing the change in the relevant information on the display 30.

[0052] The portable housing 20 houses the range sensor 12, tilt sensor 14, computing element 16, and/or other desired elements such as the display 30, one or more inputs 32, eyepiece 22, lens 24, laser emitter, laser detector, etc. The portable housing 20 enables the device 10 to be easily and safely transported and maneuvered for convenient use in a variety of locations. For example, the portable handheld housing 20 may be easily transported in a golf bag for use on a golf course. Additionally, the location of the components on or within the housing 20, such as the position of the eyepiece 22 on the proximate end 28 of the device 10, the position of the lens 24 on the distal end 26 of the device, and the location of the inputs 32, enables the device 10 to be easily and quickly operated by a user with one hand without a great expenditure of time or effort.

[0053] In operation, a user selects a desired target, such as the target T. The target T may be any physical target of which the range sensor 14 is operable to determine the first range. For example, the target T may be a pin positioned on a golf green. The user may desire to know an accurate range to the pin, or other such target, and thus which club to use. To determine the first range, angle, and the second range, the user aligns the device 10 with the target by looking through the eyepiece 22 and directing the lens 24 towards the target T. By looking through the eyepiece 22, the user may view surrounding terrain in a substantially conventional manner utilizing conventional telescope or binocular capabilities. A reticle or other aiming device may be provided by the eyepiece 22, lens 24, and/or display 30 to assist the user in aligning the device, as is shown in FIG. 8.

[0054] The user may function the inputs 32 to control the operation of the device 10. For example, the user may activate the device 10, program its functionality, store data, such as the club data described above, in the memory 18, and/or determine the first range, second range, and angle by functioning one or more of the inputs 32. For example, the user may align the target T by centering the reticle over the target T function at least one of the inputs 32 to cause the range sensor 12 to determine the first range. Alternatively, the range sensor 12 may dynamically determine the first range for all aligned objects such that the user is not required to function the inputs 32 to determine the first range. Similarly, the tilt sensor 14 may dynamically determine the angle  $\theta$  for all aligned objects or the tilt sensor may determine the angle  $\theta$  when the user functions at least one of the inputs 32.

[0055] The computing element 16 may continuously determine the second range based upon the dynamic first range and angle  $\theta$ , or the computing element 16 may determine the second range when the user functions at least one of the inputs 32. Similarly, the computing element 16 may continuously determine the desired change in club length based upon the determined first range and second range, or the difference thereof, or the computing element 16 may determine the desired change in club length when the user functions at least one of the inputs 32.

[0056] The user preferably views the target T and relevant information, such as the first range, the angle  $\theta$ , the second range, the difference between the first range and the second range, the desired change in club length, or any combination thereof, by looking through the eyepiece 22. As shown in FIG. 8, the user may view displayed information generally simultaneously with the target T as the information is displayed in proximity to the reticle and target T. As discussed above, the relevant information may be dynamically displayed on the display 30 to enable the user to simultaneously view the target T and the dynamic information.

[0057] Although the invention has been described with reference to the preferred embodiment illustrated in the attached drawing figures, it is noted that equivalents may be employed and substitutions made herein without departing from the scope of the invention as recited in the claims.

Having thus described the preferred embodiment of the invention, what is claimed as new and desired to be protected by Letters Patent includes the following:

1. A device for determining a range to a target, the device comprising:

- a range sensor for determining a first range to the target;
- a tilt sensor for determining an angle to the target relative to the device; and
- a computing element, coupled with the range sensor and the tilt sensor, for determining a second range to the target based on the first range and the determined angle.
2. The device as set forth in claim 1, wherein the computing element determines the second range by adjusting the first range by a factor corresponding to the determined angle.
3. The device as set forth in claim 2, wherein the factor adjusts the first range to account for an estimated trajectory of a projectile.
4. The device as set forth in claim 3, wherein the projectile is a golf ball.
5. The device as set forth in claim 4, wherein the computing element additionally determines a desired change of a golf club length which corresponds to the difference between the second range and the first range.
6. The device as set forth in claim 1, wherein the range sensor is a laser range sensor.
7. The device as set forth in claim 1, wherein the tilt sensor is an inclinometer.
8. The device as set forth in claim 1, wherein the tilt sensor determines the angle based on an orientation of the device.
9. The device as set forth in claim 1, further including a display, coupled with the computing element, for indicating the first range, the second range, and the determined angle.
10. The device as set forth in claim 1, further including a portable handheld housing for housing the range sensor, the tilt sensor, and the computing element.
11. The device as set forth in claim 1, wherein the target is at least a portion of a golf course.
12. The device as set forth in claim 1, wherein determining the second range includes multiplying the first range by the factor.
13. The device as set forth in claim 1, wherein the projectile is a bullet fired from a firearm.
14. An electronic device for determining a range to a target, the device comprising:
- a laser range sensor for determining a first range to the target;
  - a tilt sensor for determining an angle to the target relative to the device based on the orientation of the device;
  - a computing element, coupled with the distance sensor and the tilt sensor, for determining a second range to the target by adjusting the first range by a factor corresponding to the determined angle; and
  - a display, coupled with the computing element, for indicating the first range and the second range.
15. The device as set forth in claim 14, wherein the display additionally indicates the determined angle.
16. The device as set forth in claim 14, wherein the computing element additionally determines a desired change of a golf club length which corresponds to the difference between the second range and the first range.
17. The device as set forth in claim 17 wherein the display additionally indicates the change of the golf club length.
18. The device as set forth in claim 14, wherein the target is at least a portion of a golf course.
19. The device as set forth in claim 18, wherein the target is at least a portion of a golf green.
20. The device as set forth in claim 19, wherein the target is at least a portion of a pin positioned on the golf green.
21. The device as set forth in claim 14, further including a portable handheld housing for housing the laser range sensor, the tilt sensor, the computing element, and the display.
22. The device as set forth in claim 14, wherein the tilt sensor is an inclinometer.
23. The device as set forth in claim 14, wherein the factor adjusts the first range to account for an estimated trajectory of a golf ball.
24. The device as set forth in claim 23, wherein the second range is determined utilizing the factor such that the estimated trajectory of the golf ball intersects the target.
25. The device as set forth in claim 14, further including a memory for storing a look-up table having a plurality of angles and corresponding factors.
26. The device as set forth in claim 25, wherein the factor is determined by looking up the determined angle in the look-up table.
27. The device as set forth in claim 14, wherein the computing element determines the second range by multiplying the first range by the factor.
28. The device as set forth in claim 14, wherein the computing element determines the second range by multiplying the first range by the factor and adding the result to the first range.
29. A computer program comprising a combination of code segments stored in a computer-readable memory and executable by a computing element, the computer program comprising:
- a code segment operable to determine a first range to a target based on a first input;
  - a code segment operable to determine an angle to the target relative to the device based on a second input; and
  - a code segment operable to determine a second range to the target by adjusting the first range by a factor corresponding to the determined angle.
30. The computer program as set forth in claim 29, further including a look-up table having a plurality of angles and corresponding factors.
31. The computer program as set forth in claim 30, further including a code segment operable to determine the factor by looking up the determined angle in the look-up table.
32. The computer program as set forth in claim 29, wherein the first input is provided by a laser range sensor.
33. The computer program as set forth in claim 29, wherein the second input is provided by a tilt sensor.
34. The computer program as set forth in claim 29, further including a code segment operable to calculate a desired change of a golf club length which corresponds to the difference between the second range and the first range.
35. The computer program as set forth in claim 29, further including a code segment operable to provide inputs to a display for indicating the first range, the second range, and the determined angle.
36. The computer program as set forth in claim 29, wherein the factor adjusts the first range to account for an estimated trajectory of a golf ball.

37. The computer program as set forth in claim 36, wherein the second range is determined utilizing the factor such that the estimated trajectory of the golf ball intersects the target.

38. The computer program as set forth in claim 29, wherein determining the second range includes multiplying the first range by the factor.

39. A method for utilizing a portable electronic device to determine a range to a target, the method comprising the steps of:

determining a first range from the device to the target with a laser range sensor;

determining an angle to the target relative to the device with a tilt sensor;

determining a second range to the target by adjusting the first range by a factor corresponding to the determined angle, and

indicating the first range, the angle, and the second range.

40. The method as set forth in claim 39, wherein the angle is determined based on the orientation of the device.

41. The method as set forth in claim 39, wherein the target is at least a portion of a golf course.

42. The method as set forth in claim 41, wherein the target is at least a portion of a golf green.

43. The method as set forth in claim 42, wherein the target is at least a portion of a pin positioned on the golf green.

44. The method as set forth in claim 39, wherein the factor adjusts the first range to account for an estimated trajectory of a golf ball.

45. The method as set forth in claim 44, wherein the second range is determined such that the estimated trajectory of the golf ball intersects the target.

46. The method as set forth in claim 39, additionally including the step of determining a desired change of a golf club length which corresponds to the difference between the second range and the first range.

47. The method as set forth in claim 39, wherein determining the second range includes multiplying the first range by the factor.

\* \* \* \* \*