

W. S. FOSTER.

Car-Brakes.

No. 133,844.

Patented Dec. 10, 1872.

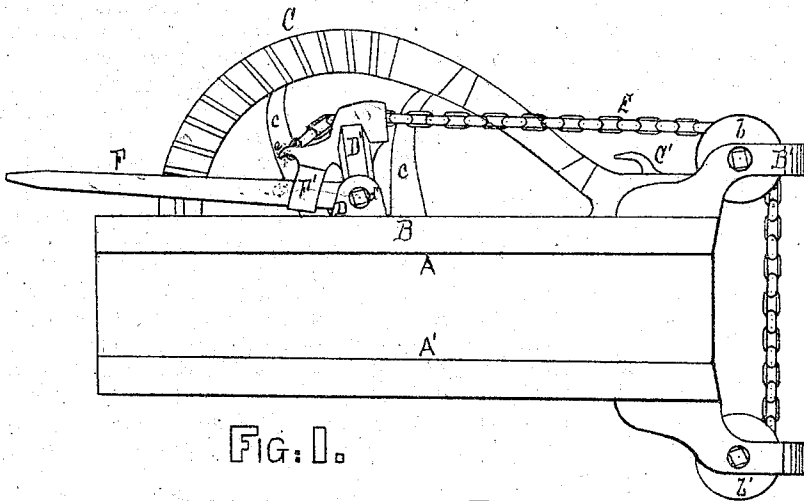

FIG: 1.

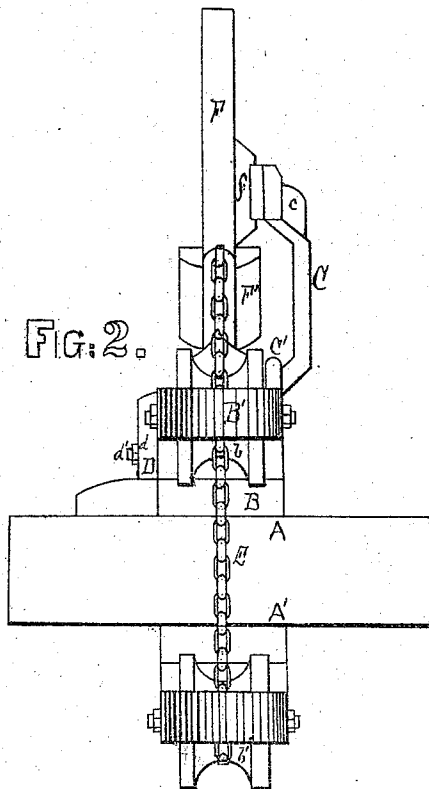

FIG: 2.

WITNESSES.

Edwin James

A. Brown

INVENTOR.

William S. Foster.

per J. E. D. Holmead

Attorney.

UNITED STATES PATENT OFFICE.

WILLIAM S. FOSTER, OF FOSTER'S CROSSING, OHIO.

IMPROVEMENT IN CAR-BRAKES.

Specification forming part of Letters Patent No. **133,844**, dated December 10, 1872.

To all whom it may concern:

Be it known that I, WILLIAM S. FOSTER, of Foster's Crossing, in the county of Warren and State of Ohio, have invented certain new and useful Improvements in Car-Brakes; and I do hereby declare that the following is a full, clear, and exact description of the same, reference being had to the accompanying drawing and to the letters of reference marked thereon making part of this specification, in which—

Figure 1 is a side view, and Fig. 2 is an end view.

This invention relates to an improved head or operating mechanism for railroad-car brakes, and forms a cheap and durable device designed to be attached to the roof of a passenger or freight car. The nature of my invention consists in casting the bed-piece, ratchet-rack, ears for securing the nave of the segment and lever, retaining-hook, and protruding forked arm for securing a sheave designed to work on a line with the sheave on the floor of the car, all in one piece, in combination with a segment, lever, and chain when these several devices are so connected as to operate in the manner hereinafter described.

While I am aware that brake-heads somewhat resembling mine have heretofore been used, still in none of them with which I am familiar is there any such combination of mechanism as the one hereinafter detailed; and as each and every feature of the combination performs an appropriate and important function it is believed that the present device is more effective and reliable than any other one of this character heretofore used.

To enable others skilled in the art to make and use my invention, I will now proceed to describe its construction and operation.

A and A' represent sections of the roof and floor of a railroad car, to the former of which is secured my improved brake-head. B is the bed-piece, and is of the usual flat-plate form, but unlike any other plate of this character heretofore used in this class of inventions. It terminates at its forward end in a forked or U-shaped arm, B', that projects some distance beyond the plate, and which is designed to secure the pivot-bolt to which is attached the sheave or pulley *b*. The advantage of this arrangement will readily suggest itself to all

practical railroad men. This pulley or sheave *b* is secured in its bearings at such relative position to the roof that it protects the same from all frictional contact with the chain and the wear and tear incident thereto, precisely as in all such brakes the pulley *b'* protects the floor. C is a curved ratchet-rack, and is cast in one piece with the plate B, as is also the hook C'. This rack C is designed to lock the lever at any desired point when the brake is set, and the hook C' is provided as an additional security, and is of great importance, especially in case anything in connection with the lever or segment should become disarranged. *c c* are radial arms and serve to strengthen the ratchet-rack C. D D are bearing-plates for the segment; or instead of plates a recessed bracket or standard may be used. These are also cast in one piece with the bed-plate B. *d d* are journal-bearings in the plates D D, and in which rests the shaft or axle *d'* of the segment D', the nave of which enters between the plates D D and is secured so as to work freely therein on its shaft or axle *d'*. This segment D' has a scored or recessed periphery which carries the chain E that is attached to the hook *e*. F is the operating-lever, and is secured in the nave of the segment and at such relative position that the recess through which passes the axle *d'* shall always work on a line with the center of the lever, and the lever may be secured in position by this axle-shaft *d'*, as shown in Fig. 2. This lever F has also an additional bearing, as shown at F, and is provided with a steel lip, *f*, by which it is caught and held in the ratchet-rack at any desired point.

From the foregoing description the operation of the machine will readily be understood. The brake-head can be securely bolted to the roof of the car by simply inserting two bolts. The chain is attached to the hook *e* and carried over the segment D' and sheave *b*, down in front of the car, over the sheave *b'*, and attached to the brake-head. When it is desired to set the brake, you have simply to depress the lever, as shown in Fig. 1, the lip *f* in connection with the ratchet-rack locking it at any desired point, the hook C serving as an additional attachment whenever occasion may require, and which is often the case. The grade not unfrequently is quite heavy, and in such

cases this hook C' acts as an additional security. But it is of the greatest importance in case anything connected with either the lever or ratchet-segment should become broken or otherwise inoperative, and which would render any other brake of this class valueless; then the hook C' can be used instead of the segment for retaining the chain at any desired point.

Another important advantage is this: The roofs of the buildings in which cars are kept are frequently very low; indeed, so low as to render it impossible for the car to be pushed under if the lever F is elevated. With all other brakes of this character you cannot lower the lever without putting the brake on. But with my improvement you simply detach the chain from the hook e and fasten it on the hook C, thus preventing the chain from run-

ning down, and leave the lever perfectly free to fall without in any manner affecting the brake, and still leaving the chain in position to be attached the moment desired.

Having thus fully described my invention, what I claim therein as new, and desire to secure by Letters Patent of the United States, is—

The bed-piece B terminating at its forward end in a projecting U-shaped slotted arm, B', and having ratchet-rack C, hook C', recessed segment D' having hook e, and lever F, when the same are so combined and arranged as to operate and retain the chain E of the brake, substantially in the manner described.

WILLIAM S. FOSTER.

Witnesses:

SAM. PAXTON,
R. M. JOHNSON.