

S. H. GILMAN.
STEAM REGULATOR AND CUT-OFF.

No. 7,987.

Patented Mar. 18, 1851.

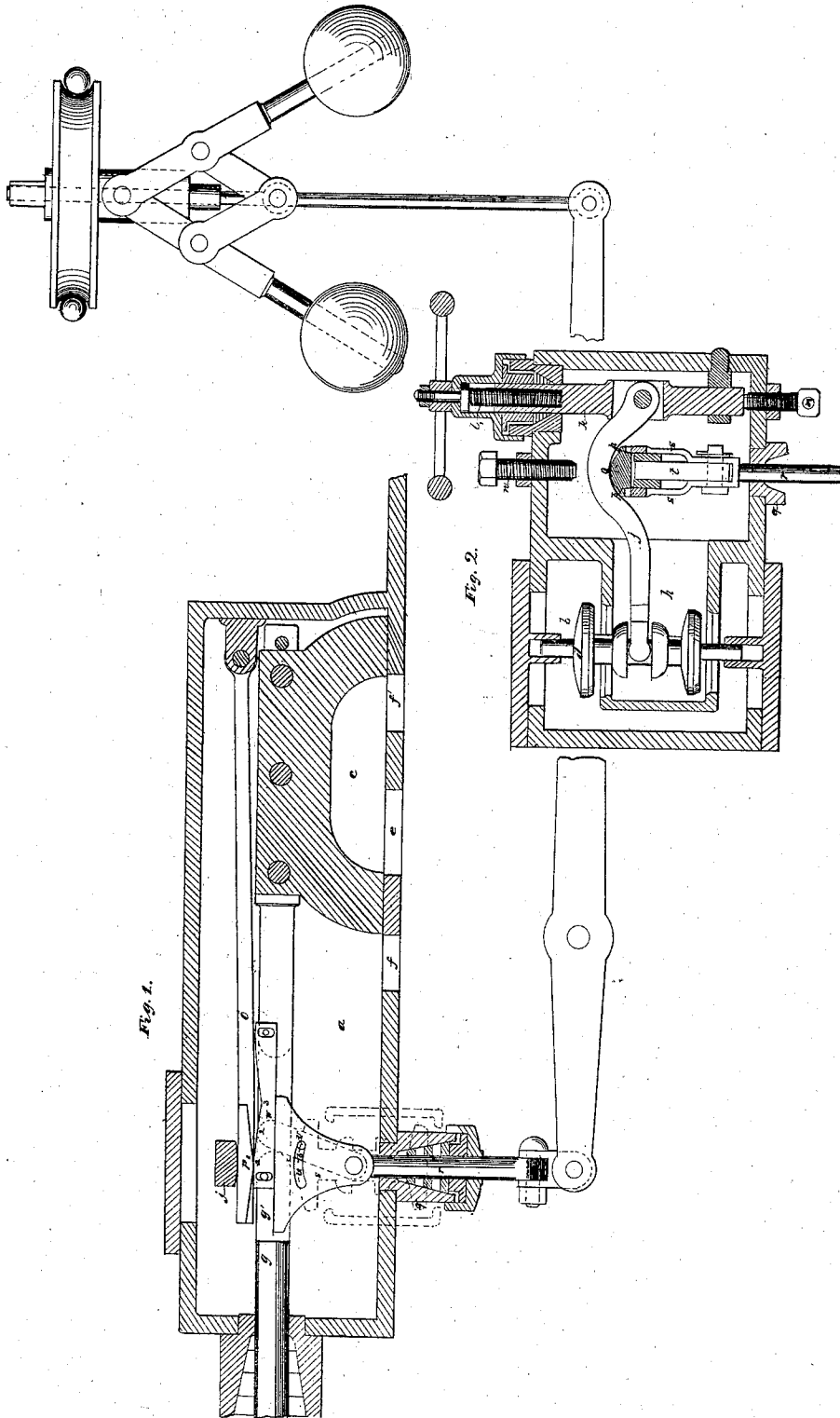

UNITED STATES PATENT OFFICE.

SAML. H. GILMAN, OF CINCINNATI, OHIO.

ADJUSTABLE CUT-OFF.

Specification of Letters Patent No. 7,987, dated March 18, 1851.

To all whom it may concern:

Be it known that I, SAMUEL H. GILMAN of Cincinnati, Hamilton County, Ohio, have invented new and useful Devices for Regulating the Admission of Steam to Steam-Engines; and I do hereby declare the following to be a full, clear, and exact description thereof, reference being had to the annexed drawings, making part of this specification.

The principal objects of my improvements are 1st The application to a slide steam valve of an arrangement of cut off mechanism, actuated by the movement of the valve rod, and having the periods of its cut off action either subject to the momentary control of the engineer or dependent on the movement of the steam governor thus constituting the cut off action a means of regulation of the rate of the engine. 2d In the devices whereby a portion of the cut off apparatus is made operable as a throttle valve.

In the accompanying drawings Figure 1 is a vertical section parallel to the path of the slide valve. Fig. 2 is a vertical section through the puppet valve at right angles to the first named.

The same letters refer to like parts in the several figures.

(*a*) is the chamber of an ordinary slide valve (*c*) and (*b*) (opening into one side of it) is the chamber of a balance puppet valve (*d*).

(*e f f'*) are the usual ports. (*g*) the slide valve rod is for a portion of its length (*g'*) square-sided for purposes hereafter explained. The steam passage (*h*) of the balance puppet valve (*d*) communicates (when the valve is lifted,) from the steam supply pipe to the slide valve chamber (*a*).

(*j*) is a lever by which the puppet valve is lifted. This lever is at its rear end pivoted to a rod (*k*) which being adjusted to its proper height by the set screw (*m*), is secured thereto by the hand screw (*l*) tapped within it, or by means of the same hand screw, the lever may be drawn entirely out of reach of the lifting mechanism, and by this means the steam may be shut completely off and the apparatus be made in this way to perform the duty of a throttle valve. Upon the return of the rod (*k*), the set screw (*m*) indicates the proper position. The upward range of the lever (*j*) is determined by the set screw (*n*). Between the

lever (*j*) and the valve rod (*g*) intervenes a bar (*o*) for purposes hereinafter explained.

A stuffing box (*q*) immediately beneath the intersection of the puppet valve lever and the slide valve rod, provides for the passage up and down of a rod (*r*), which being connected by lever or other means with the governor is depressed or elevated according to the speed of the engine, or being merely provided with a handle may be adjusted by the engineer in charge. To the summit of this rod is pivoted a swinging bar or tappet (*t*) the sweep of whose vibration is limited by pins (*v*) projecting from the tappet and playing in slots (*w*) within cheeks (*s*) attached to the top of the rod (*r*). The upper end of this tappet inhabits a vertical slot within the rod (*g*), which slot is so formed that at the period of every half stroke of the slide valve, an end of the slot striking the tappet pushes it over to the opposite position. If the motion of the governor has been such, that the tappet just drops below the level of the valve rod top at the end of its sweep—the summit of the tappet impinging against the under side of the bar (*o*) will have held it and the superincumbent lever (*j*) up and at the same time by this action will have lifted the puppet valve, during the latter half of the sweep of the slide valve answering nearly to the former half of the stroke of the piston, at the end of which period, the tappet having sunk below the top of the valve rod, the bar (*o*) will again rest thereupon, and the puppet valve closing, the steam will be cut off at half stroke; but if from the rod (*r*) being drawn down—by the governor or otherwise, the tappet escapes the bar before the above period, the steam will be shut off at an earlier period of the stroke and so forth.

To enable the period of cut off to be deferred to any point beyond the half stroke the following mechanism is provided: From each side of the bar (*o*) and immediately over the cheeks (*s*) project lugs (*p*) whose under sides incline from the mid length of the lug in both directions upward so as to present an obtuse salient point whose base stretches in the direction of and equal to the stroke of the slide valve and whose height equals one half the vertical range of the tappet. (*w*) are a pair of plates formed on their upper edges in two planes inclining

downward toward each other, equal and parallel to those upon the bar. These plates, slide to and fro with the valve rod to which they are attached by pins working in vertical slots which permit of a play up and down equal to the height of their inclined planes. The cheeks (*s*) and plates *w* are so placed with respect to each other and the bar that when the rod (*r*) passes above the middle of its range, the cheeks (*s*) bearing upward against the plates (*w*) elevate the more salient portions of their top edges, above the level of the valve rod top and the height of these inclined planes being equal to the vertical range of the plates and their joint horizontal span to the sweep of the valve, the salient portions of the plates meeting as the valve rod (*g*) progresses—those of the lugs (*p*) upon the bar, the latter is thereby held up, after the tappet has ceased to act.

This action is exhibited in the drawing as it would appear at half stroke of the piston with the plates elevated to the extent adequate to cut off the steam at three quarters stroke, that is when the slide valve has traversed one fourth of its return movement, and the apex (1) of the lugs (*p*) having reached the point (2) of the plates, at which they coincide with the top of the valve rod, the bar (*o*) returns to its resting place on the top of the rail of the slide valve, and the puppet valve closes. Were the coinciding point of the plates half way between that in the instance here cited, and the center (3) of the notch, the steam would be cut off at seven eighths stroke and so forth.

The motion of the governor on the one hand and that of the cut off apparatus on

the other, should be so proportioned and adjusted the one to the other, as that the range of the former will correspond to the range of cut offs deemed most desirable.

Having thus particularly described the nature of my improvements what I claim therein as my invention and for which I desire Letters Patent is—

1. The tappet (*t*) vibrated by the impact of projections upon the slide valve rod, and lifting thereby a puppet valve which admits steam to the slide valve chamber during periods varying with the height to which the tappet is placed by the elevation or depression of the sliding rod, or other object to which it is pivoted, said rod being raised or depressed by a motion derived from the governor or communicated to it in such other manner as may be deemed expedient.

2. I claim the mechanism substantially as described for prolongation of the admission of steam beyond the period at which it would be cut off by the tappet, to wit, the sliding plate (*w*), and the intervening bar (*o*) the former with a pair of receding inclined planes or edges, and the latter with an equal and parallel pair of salient planes which by sliding upon the former, hold up the puppet valve after the tappet has ceased to act, for a period likewise depending upon the movement of the rod, which latter may be actuated as set forth in the former claim.

In testimony whereof, I have hereunto set my hand before two subscribing witnesses.

SAMUEL H. GILMAN.

Witnesses:

EDWARD A. KNIGHT,
GEO. H. KNIGHT.