

W. SELLERS.

Improvement in Automatic Steam-Hammers.

No. 132,375.

Patented Oct. 22, 1872.

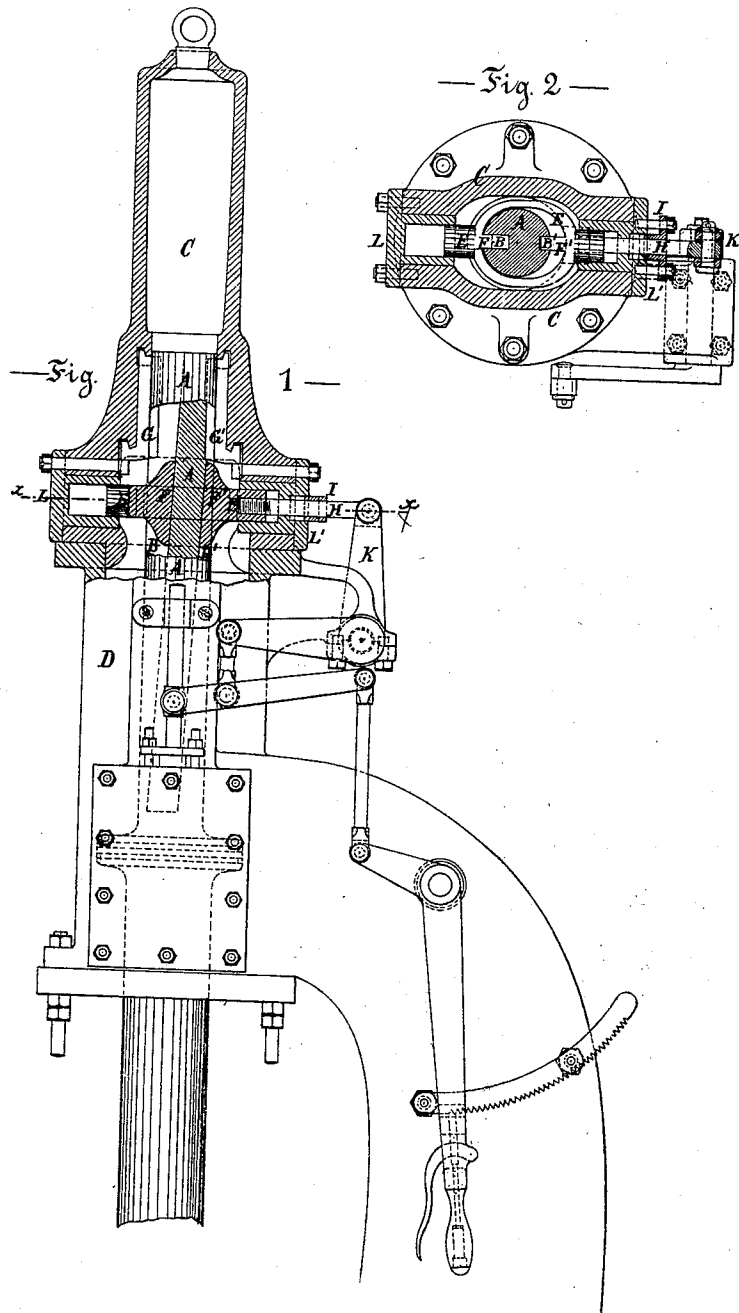

Witnesses:

Baltis de Long.
J. Thimden Sell.

Inventor:

Wm Sellers

UNITED STATES PATENT OFFICE.

WILLIAM SELLERS, OF PHILADELPHIA, PENNSYLVANIA.

IMPROVEMENT IN AUTOMATIC STEAM-HAMMERS.

Specification forming part of Letters Patent No. 132,375, dated October 22, 1872.

To all whom it may concern:

Be it known that I, WILLIAM SELLERS, of Philadelphia, Pennsylvania, have invented certain new and useful Improvements in Automatic Steam-Hammers, of which the following is a specification:

My invention relates to improvements in the valve motion of automatic steam-hammers, whereby the primary motion may be obtained from the part of the hammer-bar within the steam-space without imparting any twisting motion to the hammer-bar. In patent No. 70,369, issued to William Sellers & Co., as assignees of William and Coleman Sellers, a valve motion is described in which the primary motion is obtained from a diagonal slot in a flat face on the upper end of the hammer-bar. In this arrangement the force required to move the valve being exerted tangentially to the axis of the hammer-bar causes it to rotate to the extent allowable by wear in the guiding-keys or flat surface. To obviate this difficulty is the main object of my invention. I effect this purpose by arranging slots or grooves on opposite sides of the cylindrical hammer-bar and making the bottom of these slots or grooves inclined in relation to the axis of the hammer-bar, and then obtaining a motion from the inclined surfaces reacting radially upon the bar with no tendency to turn it.

In the accompanying drawing, Figure 1 is a side elevation, partly in section, of my improved hammer; and Fig. 2, a longitudinal section of the same at the line *x x* of Fig. 1.

A, hammer-bar above the piston; B B', radial slots in the opposite sides of the hammer-bar; C, the top cap of the steam cylinder D, covering the whole upper end of the hammer-bar in the same manner as is described in patent No. 70,369, before alluded to; E, a yoke passing around the hammer-bar and having projections F F' fitted into the slots, with surfaces inclined to correspond with the inclinations of the surfaces at the bottom of the governor-slots B and B'. G G', keys fitted in the same grooves above the yoke E, to give extended guiding-surface. A rod, H, extends through a stuffing-box, I, to the rocker-arm K, and gives motion to the valve. The yoke E, guided by its extension with caps L and L',

can move back and forth at right angles only to the vertical motion of the hammer-bar and the inclined bottom surfaces of the grooves B and B' impart this motion to it, with no tendency whatever to rotate the bar about its own axis.

My invention is of especial use in those hammers in which the piston and piston-rod form the entire weight of the hammer proper, and the die is attached to the lower end of the piston-rod or hammer-bar direct without the intervention of any "tup." Such hammers are guided by the cylinder-caps only to preserve their proper line of motion, and are usually prevented from turning by slots or grooves in the bar.

My invention, apart from its advantages in not causing a tendency to rotate, materially diminishes the friction on the guiding-surface.

I claim as my invention, and desire to secure by Letters Patent—

1. In an automatic steam-hammer, the combination of a reciprocating hammer-bar, a yoke reciprocating transversely to the line of motion of the hammer-bar, and projections on the yoke working against the inclined bottoms of slots in the hammer-bar, these parts being constructed to operate in combination, substantially as set forth.

2. In an automatic steam-hammer, the combination of a reciprocating hammer-bar, a yoke reciprocating transversely to the line of motion of the hammer-bar and guide-keys, taking in the slots of the hammer-bar, these members being constructed to operate in combination substantially as set forth.

3. In an automatic steam-hammer, the combination of a reciprocating hammer-bar, a yoke reciprocated transversely to said bar by projections working in slots therein, a packed piston-rod actuated by said yoke, and a rocker-arm connecting said piston-rod with the valve-mechanism, substantially as set forth.

In testimony whereof I have hereunto subscribed my name.

WM. SELLERS.

Witnesses:

J. SNOWDEN BELL,
EDWD. C. DAVIDSON.