



(43) International Publication Date
18 September 2014 (18.09.2014)

- (51) International Patent Classification:
H01L 31/042 (2014.01)
- (21) International Application Number:
PCT/US2014/028723
- (22) International Filing Date:
14 March 2014 (14.03.2014)
- (25) Filing Language: English
- (26) Publication Language: English
- (30) Priority Data:
13/843,573 15 March 2013 (15.03.2013) US
61/946,338 28 February 2014 (28.02.2014) US
- (72) Inventor: and
- (71) Applicant : ESTES, Christopher [US/US]; 402 Belle Point Dr., Nashville, TN 37221 (US).
- (74) Agents: DAVIS, John, Paul et al.; Wood, Herron & Evans, LLP, 2700 Carew Tower, 441 Vine Street, Cincinnati, OH 45202-2917 (US).
- (81) Designated States (unless otherwise indicated, for every kind of national protection available): AE, AG, AL, AM, AO, AT, AU, AZ, BA, BB, BG, BH, BN, BR, BW, BY,

BZ, CA, CH, CL, CN, CO, CR, CU, CZ, DE, DK, DM, DO, DZ, EC, EE, EG, ES, FI, GB, GD, GE, GH, GM, GT, HN, HR, HU, ID, IL, IN, IR, IS, JP, KE, KG, KN, KP, KR, KZ, LA, LC, LK, LR, LS, LT, LU, LY, MA, MD, ME, MG, MK, MN, MW, MX, MY, MZ, NA, NG, NI, NO, NZ, OM, PA, PE, PG, PH, PL, PT, QA, RO, RS, RU, RW, SA, SC, SD, SE, SG, SK, SL, SM, ST, SV, SY, TH, TJ, TM, TN, TR, TT, TZ, UA, UG, US, UZ, VC, VN, ZA, ZM, ZW.

(84) Designated States (unless otherwise indicated, for every kind of regional protection available): ARIPO (BW, GH, GM, KE, LR, LS, MW, MZ, NA, RW, SD, SL, SZ, TZ, UG, ZM, ZW), Eurasian (AM, AZ, BY, KG, KZ, RU, TJ, TM), European (AL, AT, BE, BG, CH, CY, CZ, DE, DK, EE, ES, FI, FR, GB, GR, HR, HU, IE, IS, IT, LT, LU, LV, MC, MK, MT, NL, NO, PL, PT, RO, RS, SE, SI, SK, SM, TR), OAPI (BF, BJ, CF, CG, CI, CM, GA, GN, GQ, GW, KM, ML, MR, NE, SN, TD, TG).

Published:

— without international search report and to be republished upon receipt of that report (Rule 48.2(g))

(54) Title: INTEGRATED SOLAR PANEL

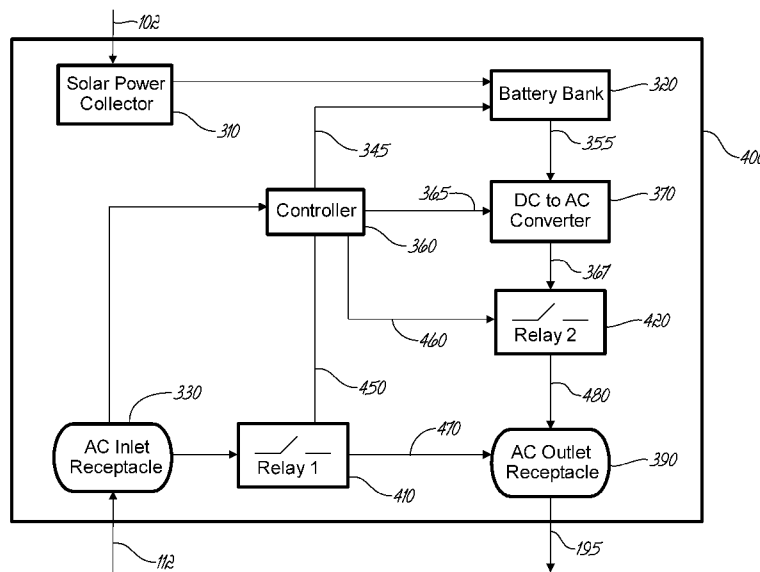

FIG. 4

(57) Abstract: A solar panel (400) is disclosed that can be daisy-chained with other solar panels (100a- n). The solar panel (400) automatically generates output alternative current (AC) power (195) that is in parallel with input AC power (112) coming into the solar panel (400) when the solar panel (400) senses the input AC power (112) so that the solar panel (400) operates as a slave in this state. The solar panel (400) automatically generates standalone AC output power (195) when the solar panel (400) fails to detect input AC power (112) coming into the solar panel (400) where the solar panel (400) operates as a master in this state. The solar panel (400) generates the standalone output AC power (195) without any reliance on input AC power (112) generated by a utility grid and/or other AC power sources external to the solar panel (400).

WO 2014/144354 A2

INTEGRATED SOLAR PANEL

BACKGROUND

CROSS-REFERNCE TO RELATED APPLICATIONS

[0001] The present application also claims the benefit of United States Appl. No. 13/843,573, filed March 15, 2013, which is incorporated herein by reference in its entirety. The present application also claims the benefit of United States Appl. No. 61/946,338, filed February 28, 2014.

Field of Disclosure

[0002] The present disclosure relates generally to solar power personal energy delivery and specifically to solar power renewable energy devices.

Related Art

[0003] Conventional solar panel systems have evolved from dependency on the collective conversion of solar energy to direct current (DC) power to reliance on other power sources when conditions limit the collection of solar energy required to adequately support the conventional systems. Conventional solar panel systems of today can now generate alternative current (AC) power when connected to a utility grid. Conventional solar panel systems that are grid tied convert the AC power generated by the utility grid into AC output power for the conventional systems. Thus, conventional solar panel systems are no longer dependent on the DC power collected from the conversion of solar energy to adequately sustain the output power generated by the conventional solar panel systems.

[0004] Conventional solar panel systems can also increase the output power of the conventional systems by daisy chaining additional conventional solar panels to the existing conventional solar panels included in the conventional systems. Conventional daisy chaining of conventional solar panels increases the AC output power of the conventional solar panel system when the conventional system is connected to the grid and receiving the AC power generated by the grid. Conventional daisy chaining of conventional solar panels also increases the DC output power of the conventional solar panel system when the conventional system is isolated from the grid and not receiving the AC power generated by the grid. Each of the components included in the conventional

solar panel systems are separate entities and not included within a single housing. For example, a conventional solar panel system for a house includes the conventional solar panels located on the roof of the house while the conventional battery system is located in the basement of the house and the conventional inverter is located on the side of the house.

[0005] Conventional solar panel systems are limited to generating AC output power to when the conventional system is connected to the grid and receiving the AC power generated by the grid. Conventional solar panel systems cannot generate AC power when isolated from the grid or cut off from the AC power generated by the grid. Conventional solar panel systems are limited to generating DC output power when isolated from the grid or cut off from the AC power generated by the grid. The DC output power is limited to DC power stored in batteries or DC power converted from solar energy. Further, the DC output power is inaccessible DC power in that the DC output power cannot be accessed from the conventional solar panel systems. For example, the conventional solar panel systems fail to include a DC output power outlet in which the DC output can be accessed.

BRIEF DESCRIPTION OF THE DRAWINGS/FIGURES

[0006] Embodiments of the present disclosure are described with reference to the accompanying drawings. In the drawings, like reference numerals indicate identical or functionally similar elements. Additionally, the left most digit(s) of a reference number identifies the drawing in which the reference number first appears.

[0007] FIG. 1 illustrates a block diagram of a first exemplary solar panel according to an exemplary embodiment of the present disclosure;

[0008] FIG. 2 illustrates a block diagram of a solar panel configuration according to an exemplary embodiment of the present disclosure;

[0009] FIG. 3 is a block diagram of a second exemplary solar panel that may be used in the solar panel configuration according to an exemplary embodiment of the present disclosure;

[0010] FIG. 4 is a block diagram of a third exemplary solar panel that may be used in the solar panel configuration according to an exemplary embodiment of the present disclosure;

- [0011] FIG. 5 is a block diagram of a fourth exemplary solar panel that may be used in the solar panel configuration according to an exemplary embodiment of the present disclosure;
- [0012] FIG. 6 illustrates a block diagram of a second exemplary solar panel configuration according to an exemplary embodiment of the present disclosure;
- [0013] FIG. 7 shows an illustration of a wireless solar panel configuration;
- [0014] FIG. 8 is a flowchart of exemplary operational steps of the solar panel according to an exemplary embodiment of the present disclosure;
- [0015] FIG. 9 illustrates a block diagram of a solar panel connector configuration according to an exemplary embodiment of the present disclosure;
- [0016] FIG. 10 illustrates a block diagram of a solar panel connector configuration according to an exemplary embodiment of the present disclosure;
- [0017] FIG. 11 illustrates a block diagram of a solar panel connector configuration according to an exemplary embodiment of the present disclosure;
- [0018] FIG. 12 illustrates an example solar panel connector according to an exemplary embodiment of the present disclosure; and
- [0019] FIG. 13 is a flowchart of exemplary operational steps of the solar panel connector configuration according to an exemplary embodiment of the present disclosure.
- [0020] The present disclosure will now be described with reference to the accompanying drawings. In the drawings, like reference numbers generally indicate identical, functionally similar, and/or structurally similar elements. The drawings in which an element first appears is indicated by the leftmost digit(s) in the reference number.

DETAILED DESCRIPTION OF THE PRESENT DISCLOSURE

- [0021] The following Detailed Description refers to accompanying drawings to illustrate exemplary embodiments consistent with the present disclosure. References in the Detailed Description to “one exemplary embodiment”, “an exemplary embodiment”, an “example exemplary embodiment”, etc., indicate that the exemplary embodiment described may include a particular feature, structure, or characteristic, but every exemplary embodiment may not necessarily include the particular feature, structure, or characteristic. Moreover, such phrases are not necessarily referring to the same exemplary embodiment. Further, when a particular feature, structure, or characteristic

may be described in connection with an exemplary embodiment, it is within the knowledge of those skilled in the art(s) to affect such feature, structure, or characteristic in connection with other exemplary embodiments whether or not explicitly described.

[0022] The exemplary embodiments described herein are provided for illustrative purposes, and are not limiting. Other exemplary embodiments are possible, and modifications may be made to the exemplary embodiments within the spirit and scope of the present disclosure. Therefore, the Detailed Description is not meant to limit the present disclosure. Rather, the scope of the present disclosure is defined only in accordance with the following claims and their equivalents.

[0023] Embodiments of the present disclosure may be implemented in hardware, firmware, software, or any combination thereof. Embodiments of the present disclosure may also be implemented as instructions stored on a machine-readable medium, which may be read and executed by one or more processors. A machine-readable medium may include any mechanism for storing or transmitting information in a form readable by a machine (e.g., a computing device). For example, a machine-readable medium may include read only memory (ROM); random access memory (RAM); magnetic disk storage media; optical storage media; flash memory devices; electrical optical, acoustical or other forms of propagated signals (e.g., carrier waves, infrared signals, digital signals, etc.), and others. Further firmware, software routines, and instructions may be described herein as performing certain actions. However, it should be appreciated that such descriptions are merely for convenience and that such actions in fact result from computing devices, processors, controllers, or other devices executing the firmware, software, routines, instructions, etc.

[0024] For purposes of this discussion, each of the various components discussed may be considered a module, and the term “module” shall be understood to include at least one of software, firmware, and hardware (such as one or more circuit, microchip, or device, or any combination thereof), and any combination thereof. In addition, it will be understood that each module may include one, or more than one, component within an actual device, and each component that forms a part of the described module may function either cooperatively or independently of any other component forming a part of the module. Conversely, multiple modules described herein may represent a single component within

an actual device. Further, components within a module may be in a single device or distributed among multiple devices in a wired or wireless manner.

[0025] The following Detailed Description of the exemplary embodiments will so fully reveal the general nature of the present disclosure that others can, by applying knowledge of those skilled in the relevant art(s), readily modify and/or adapt for various applications such exemplary embodiments, without undue experimentation, without departing from the spirit and scope of the present disclosure. Therefore, such adaptations and modifications are intended to be within the meaning and plurality of equivalents of the exemplary embodiments based upon the teaching and guidance presented herein. It is to be understood that the phraseology or terminology herein is for the purpose of description and not of limitation, such that the terminology or phraseology of the present specification is to be interpreted by those skilled in relevant art(s) in light of the teachings herein.

A FIRST EXEMPLARY SOLAR PANEL

[0026] FIG. 1 illustrates a block diagram of a first exemplary solar panel according to an exemplary embodiment of the present disclosure. A solar panel 100 may be a standalone alternating current (AC) power generating device. The solar panel 100 is not limited to generating output AC power 195 by passing through input AC power 112 received from a utility grid into the output AC power 195 when the solar panel 100 is coupled to the utility grid. Rather, the solar panel 100 may still generate standalone output AC power 195 when isolated from the utility grid and not receiving the input AC power 112 from the utility grid. Further, the solar panel 100 may parallel the AC output power 195 generated from the inverted DC power provided by the DC battery with the input AC power 112 when the AC power 195 is synchronized with the input AC power 112.

[0027] The solar panel 100 may receive input AC power 112. The input AC power 112 may be AC power that is generated by the grid. The solar panel 100 may receive the input AC power 112 generated by the grid when the solar panel 100 is coupled to the grid. One of ordinary skill in the art may refer to the state of the solar panel 100 as being grid tied when the solar panel 100 is coupled to the grid and receives the input AC power 112 generated by the grid. One of ordinary skill in the art may refer to the state of the solar panel 100 as not being grid tied when the solar panel 100 is isolated from the grid.

The input AC power 112 may also be AC power generated by a second solar panel when the solar panel 100 is coupled to the second solar panel. The input AC power 112 may also be AC power generated by an AC power generator, AC power inverter, a sinusoidal AC power inverter, and/or any other type of AC power source independent from the solar panel 100 that will be apparent to those skilled in the relevant art(s) without departing from the spirit and scope of the disclosure.

[0028] The solar panel 100 may generate the output AC power 195 that is in parallel with the input AC power 112 when the output AC power 195 is synchronized with the input AC power 112. The solar panel 100 may sense the input AC power 112 when the solar panel 100 is grid tied. The solar panel 100 may also sense the input AC power 112 when the solar panel is coupled to the second panel and the second panel is providing the input AC power 112 to the solar panel 100. The solar panel 100 may synchronize the output AC power 195 generated from the input AC power 112 to be substantially equivalent to the power signal characteristics of the input AC power 112. The power signal characteristics may include but are not limited to frequency, phase, amplitude, current, voltage and/or any other characteristic of a power signal that will be apparent to those skilled in the relevant art(s) without departing from the spirit and scope of the disclosure. The solar panel 100 may store the power signal characteristics of the input AC power 112.

[0029] The output AC power 195 generated by the solar panel 100 may be AC power that may be used to power electronic devices external to the solar panel 100, such as a hairdryer, for example. The output AC power 195 may also be AC power that may be provided to a third solar panel. The solar panel 100 may also convert the input AC power 112 to DC power and store the DC power internally to the solar panel 100 when the solar panel is receiving the input AC power 112 but not providing the output AC power 195 to the external electronic devices and/or the third solar panel.

[0030] The solar panel 100 may continue to provide standalone output AC power 195 after the solar panel 100 is no longer receiving the AC input power 112 thus the solar panel 100 is not reliant on any other source to generate the standalone output AC power 195. For example, the solar panel 100 continues to provide standalone output AC power 195 after the solar panel is no longer grid tied such that the solar panel 100 is no longer

receiving the AC input power 112 from the grid. In another example, the solar panel 100 continues to provide standalone output AC power 195 after the solar panel 100 is no longer receiving the AC input power 112 from the second solar panel.

[0031] The solar panel 100 may sense when the solar panel 100 is no longer receiving the AC input power 112. The solar panel 100 may then internally generate the standalone output AC power 195 from the previously stored DC power by the solar panel 100. For example, the solar panel 100 may have previously stored DC power that was converted from the input AC power 112 when the solar panel 100 was receiving the input AC power 112. In another example, the solar panel 100 may also have previously stored the DC power that was converted from the solar energy 102 captured by the solar panel 100.

[0032] The solar panel 100 may internally generate the standalone output AC power 195 by converting the previously stored DC power into the AC output power 195. In an embodiment, the solar panel 100 may synchronize the power signal characteristics of the standalone AC output power 195 that was converted from the previously stored DC power to be substantially equivalent to the power signal characteristics of the input AC power 112. The solar panel 100 may internally generate the standalone output AC power 195 that is in parallel with the input AC power 112 when the output AC power 195 is in parallel with the input AC power 112. For example, the solar panel 100 synchronizes the standalone AC output power 195 that was converted from the previously stored DC power to have substantially equivalent frequency, phase, amplitude, voltage and/or current as the input AC power 112 when the solar panel was receiving the input AC power 112. Thus, the solar panel 100 provides the standalone output AC power 195 in parallel with the input AC power 112 when the solar panel 100 is no longer receiving the input AC power 112 while providing such standalone AC output power 195 with substantially similar power signal characteristics of the input AC power 112.

[0033] The solar panel 100 may be scalable in size and may be able to provide various levels of output power. For example, the solar panel 100 may be a portable model that may output approximately 250W. In another example, the solar panel 100 may be a permanent rooftop model that may output 2.5kW.

[0034] The solar panel 100 may also be efficient. The solar panel 100 may include each of the necessary components required to generate the output AC power 195 within a

single housing for the solar panel 100. For example, as will be discussed in more detail below, the solar power collector, battery bank, DC to AC converter, controller, and/or each other necessary component required to generate the output AC power 195 may be housed within a single housing for the solar panel 100. The housing of each necessary component within the single housing for the solar panel 100 minimizes the amount of cabling required for the solar panel 100 so that transmission loss from the cabling is minimized.

[0035] The solar panel 100 may also be relatively user friendly in that an individual may find that operating the solar panel 100 requires relatively minimal effort for the individual. For example, as will be discussed in more detail below, the individual simply plugs in an external electrical device into the outlet provided by the solar panel 100 to power the external electrical device. In another example, the individual simply plugs in an additional solar panel into the outlet provided by the solar panel 100 to daisy chain the additional solar panel to the solar panel 100. In yet another example, the solar panel 100 that is daisy chained to the additional solar panel automatically establish a master slave relationship so that the individual is not required to manually designate the master and the slave.

AN EXEMPLARY SOLAR PANEL CONFIGURATION

[0036] FIG. 2 illustrates a block diagram of a solar panel configuration according to an exemplary embodiment of the present disclosure. The solar panel configuration 200 represents a solar panel configuration that includes a plurality of solar panels 100a through 100n that may be daisy chained together to form the solar panel configuration 200, where n is an integer greater than or equal to two. Each solar panel 100a through 100n that is added to the solar panel configuration 200 may generate the output AC power 195n that is in parallel with the output AC power 195a and the output AC power 195b of the solar panel configuration 200. The solar panel configuration 200 shares many similar features with the solar panel 100; therefore, only the differences between the solar panel configuration 200 and the solar panel 100 are to be discussed in further detail.

[0037] As noted above, the solar panel 100a generates the output AC power 195a. However, the solar panel 100a may be limited to a maximum output power level for the

output AC power 195a. For example, the solar panel 100a is limited to the maximum output power level of 500 Watts (W) for the output AC power 195a. Regardless of the input power level of the input AC power 112a, the maximum output AC power 195a for the solar panel 100a is 500W. However, an individual desires to power a hair dryer that requires 1500W to operate. The solar panel 100a cannot power the hair dryer with the maximum output AC power 195 of 500W.

[0038] Additional solar panels 100b through 100n may be daisy chained to the solar panel 100a to parallel the output AC power 195a so that the overall output power of the solar panel configuration 200 is increased. In daisy chaining the plurality of solar panels 100a through 100n, each power input for each solar panel 100b through 100n is coupled to a power output of a solar panel 100b through 100n that is ahead of the solar panel 100b through 100n in the daisy chain configuration. For example, the power input of the solar panel 100b is coupled to the power output of the solar panel 100a so that the input AC power 195a received by the solar panel 100b is substantially equivalent to the output AC power 195a of the solar panel 100a. The power input of the solar panel 100n is coupled to the power output of the solar panel 100b so that the input AC power 195b received by the solar panel 100n is substantially equivalent to the output AC power 195b of the solar panel 100b.

[0039] After daisy chaining each of the plurality of solar panels 100a through 100n, each output AC power 195a through 195n may be paralleled with each input AC power 112a, 195a, and/or 195b to increase the overall output AC power of the solar configuration 200. The output AC power 195n generated by the last solar panel 100n in the daisy chain of the solar configuration 200 may be increased relative to the output AC power 195a generated by the first solar panel 100a in the daisy chain of the solar configuration 200. For example, the maximum output AC power 195a for the solar panel 100a is 500W. The maximum output power that can be generated by the solar panel 100b is also 500W. However, the solar panel 100b is daisy chained to the solar panel 100a so that the AC input power 195a for solar panel 100b is in parallel with the AC output power 195b of the solar panel 100b. The output AC power 195a for the solar panel 100b is 500W. The solar panel 100b generates a maximum output AC power of 500W in parallel with the input AC power 195a of 500W to generate the output AC power 195b of 1000W. The

solar panel 100n is daisy chained to the solar panel 100b in a substantially similar manner to generate the output AC power 195n of 1500W. The output AC power 195n of 1500W is now sufficient to power the hair dryer that requires 1500W to operate. The daisy chaining of each of the plurality of solar panels 100a through 100n when the plurality of solar panels 100a through 100n are not grid tied but generating standalone output AC power 195n may be considered a standalone solar micro grid.

[0040] Each of the solar panels 100a through 100n included in the solar panel configuration 200 may operate in a master/slave relationship with each other. The master may be the originator of the standalone AC power for the solar panel configuration 200. The master may determine the power signal characteristics of the standalone AC power originated by the master in that each of the remaining slaves included in the solar panel configuration 200 may be required to synchronize each of their own respective AC power outputs to. Each respective AC power output that is synchronized to the standalone AC power originated of the master may be paralleled with the standalone AC power for the master. For example, the utility grid is the master of the solar panel configuration 200 when the utility grid is the originator of the input AC power 112a provided to the solar panel 100a. The utility grid determines the frequency, phase, amplitude, voltage and current for the input AC power 112a. Each solar panel 100a through 100n then become slaves and synchronize each of their respective output AC power 195a through 195n to have substantially equivalent frequency, phase, amplitude, and current as the input AC power 112a. Each output AC power 195a through 195 that is synchronized with input AC power 112a is paralleled with the input AC power 112a.

[0041] Each of the solar panels 100a through 100n may operate as a slave for the solar panel configuration 200 when each of the solar panels 100a through 100n is receiving input AC power. Each of the solar panels 100a through 100n may operate as a master when each of the solar panels 100a through 100n no longer receives input AC power. For example, each of the solar panels 100a through 100n operate as the slave when the solar panel configuration 200 is grid tied so that the utility grid operates as the master for the solar panel configuration 200. Each of the solar panels 100a through 100n is receiving input AC power via input AC power. The solar panel 100a is receiving the input AC power 112a from the grid making the solar panel 100a the slave while the solar

panel 100b receives the input AC power 195a from the solar panel 100a making the solar panel 100b the slave and the solar panel 100c receives the input AC power 195b from the solar panel 100b making the solar panel 100c the slave.

[0042] In another example, the solar panel 100a operates as the master for the solar panel configuration 200 when the solar panel configuration 200 is no longer grid tied and the solar panel 100a is generating the standalone output AC power 195a. Each of the solar panels 100b through 100n is receiving input AC power via the standalone output AC power 195a internally generated by the master solar panel 100a. The solar panel 100b receives the input AC power 195a from the solar panel 100a and the solar panel 100c receives the input AC power 195b from the solar panel 100b.

[0043] The solar panel configuration 200 may automatically transition the master/slave designations between each of the solar panels 100a through 100n without user intervention. As noted above, the solar panel 100a through 100n may be designated as the master of the solar panel configuration 200 when the solar panel 100a through 100n no longer receives input AC power. However, the master solar panel 100a through 100n may automatically transition to the slave when the master solar panel 100a through 100n senses input AC power coming into the master solar panel 100a through 100n. At that point, the solar panel 100a through 100b may automatically terminate the internal generation of its own standalone output AC power from its own previously stored DC power. The solar panel 100a through 100n may automatically synchronize to the power signal characteristics of the input AC power now being received by the solar panel 100a through 100b to parallel the output AC power generated by each solar panel 100a through 100b with input AC power. The solar panel 100a through 100n is no longer a master and transitions to a slave begins generating output AC power from the input AC power now being received by it.

[0044] For example, the solar panel 100b operates as a master. The solar panel 100b is not receiving input AC power but is internally generating its own standalone output AC power 195b from its own previously stored DC power. The solar panel 100b continues to operate as the master until the solar panel 100b senses input AC power 195a now being received by the solar panel 100b. The solar panel 100a is now coupled to the solar panel 100b and is generating the input AC power 195a now being received by the solar panel

100b. The solar panel 100b then automatically terminates internally generating its own standalone output AC power 195b from its own previously stored DC power. The solar panel 100b automatically synchronizes the standalone output AC power 195b to the frequency, phase, amplitude, and current of the input AC power 195a now being received from the solar panel 100a to parallel the standalone output AC power 195b to the input AC power 195a. The solar panel 100b then transitions to the slave when the solar panel 100b generates the output AC power 195b from the input AC power 195a rather than its own previously stored DC power.

[0045] The solar panel configuration 200 may also automatically transition the slave solar panels 100a through 100n to a master without user intervention. As noted above, the solar panel 100a through 100n may be designated as the slave of the solar panel configuration 200 when the solar panel 100a through 100n is receiving input AC power. However, the slave solar panel 100a through 100n may automatically transition to the master when the slave solar panel 100a through 100n no longer senses input AC power coming into the slave solar panel 100a through 100n. At that point, the solar panel 100a through 100n may automatically begin internally generating its own standalone output AC power from its own previously stored DC power. The solar panel 100a through 100n may have stored the power signal characteristics of the input power previously received by the solar panel 100a through 100n. The solar panel 100a through 100n may automatically synchronize its own standalone output AC power to the input AC power no longer received by the solar panel 100a through 100n based on the stored power signal characteristics to parallel the standalone output AC power to the input AC power. The solar panel 100a through 100b is no longer a slave and transitions to a master when the solar panel 100a through 100b begins internally generating its own standalone output AC power from its own previously stored DC power.

[0046] The solar panel configuration 200 may continue to generate output AC power despite when the slave solar panel 100a through 100n is no longer functional. The dysfunctional slave solar panel 100a through 100n may continue to pass through the standalone output AC power generated by the master solar panel 100a through 100n to each of the other slave solar panels 100a through 100n. For example, the master solar panel 100a acts as the master and the solar panels 100b and 100n act as the slaves. If the

slave solar panel 100b fails and is no longer functional, the dysfunctional slave solar panel 100b continues to pass through the output standalone AC power 195a generated by the master solar panel 100a to the functional slave solar panel 100n so that the functional slave solar panel 100n continues to generate the output AC power 195n from the standalone output AC power 195a.

A SECOND EXEMPLARY SOLAR PANEL

[0047] FIG. 3 is a block diagram of a second exemplary solar panel 300 that may be used in the solar panel configuration 200 according to an exemplary embodiment of the present disclosure. Although, FIG. 3 depicts a block diagram of the solar panel 300, one of ordinary skill in the art will recognize that FIG. 3 may also depict a block diagram of the plurality of solar panels 100a through 100n used in the solar panel configuration 200 depicted in FIG. 2 and also the solar panel 100 depicted in FIG. 1. The solar panel 300 may automatically transition to internally generating standalone output AC power 195 based on the stored DC power 355 provided by the battery bank 320 when the power signal sensor 340 no longer senses the received input AC power 315. The solar panel 300 may also automatically transition to operating as a master when the power signal sensor 340 no longer senses the received input AC power 315. The solar panel 300 may also automatically transition to operating as a slave when the power signal sensor 340 begins to sense the received input AC power 315.

[0048] The solar panel 300 may be implemented using a solar power collector 310, a battery bank 320, an AC inlet receptacle 330, a power signal sensor 340, a power signal synchronizer 350, a controller 360, a direct current (DC) to AC converter 370, a power signal synchronizer 380, and an AC outlet receptacle 390. Each of which are enclosed within a housing for the solar panel 300. The solar panel 300 shares many similar features with the solar panel 100 and the plurality of solar panels 100a through 100n; therefore, only the differences between the solar panel 300 and the solar panel 100 and the plurality of solar panels 100a through 100n are to be discussed in further detail.

[0049] Solar panel collector 310 captures the solar energy 102 from a solar source. The solar panel collector 310 may include a single and/or multiple photovoltaic solar panels that convert the solar energy 102 into the captured DC power 305. The solar panel collector 310 may capture the solar energy 102 when the solar source is available and is

radiating the solar energy 102 in a sufficient manner for the solar panel collector 310 to capture. The solar panel collector 310 may convert the solar energy 302 into the DC captured power 305 in a wide range of voltages and/or current capacities. The solar panel collector 310 may include photovoltaic solar panels categorized as but not limited to mono-crystalline silicon, poly-crystalline silicon, amorphous silicon, cadmium telluride, copper indium selenide, thin-film layers, organic dyes, organic polymers, nanocrystals and/or any other type of photovoltaic solar panels that will be apparent to those skilled in the relevant art(s) without departing from the spirit and scope of the disclosure. The solar panel collector 310 may also be any shape and/or size that are sufficient to capture the solar energy 102 that will be apparent to those skilled in the relevant art(s) without departing from the spirit and scope of the disclosure.

[0050] The battery bank 320 receives and stores the captured DC power 305. The battery bank 320 accumulates the captured DC power 305 as the captured DC power 305 is generated. The battery bank 320 may accumulate the captured DC power 305 until the battery bank 320 is at capacity and can no longer store any more of the captured DC power 305. The battery bank 320 may also store the AC input power 112 that is converted to the captured DC power 305 when the AC output receptacle 390 is not generating the output AC power 195. The battery bank 320 stores the captured DC power 305 until requested to provide the stored DC power 355. The stored DC power 355 provided by the battery bank 320 may include low-voltage but high energy DC power. The battery bank 320 may include one or more lithium ion phosphate (LiFePO_4) and/or one or more lead acid cells. However, this example is not limiting, those skilled in the relevant art(s) may implement the battery bank 320 using other battery chemistries without departing from the scope and spirit of the present disclosure. The one or more cells of the battery bank 320 convert chemical energy into electrical energy via an electromechanical reaction.

[0051] As noted above, the solar panel 300 may automatically transition between the master and/or slave designations without user intervention. The solar panel 300 may be operating as a slave when the AC inlet receptacle 330 is receiving the AC input power 112. The input AC power 112 may be AC power that is generated by the grid. The AC inlet receptacle 330 may receive the input AC power 112 when the AC inlet receptacle

330 is grid tied. The input AC power 112 may also be AC power generated by a second solar panel when the AC inlet receptacle 330 is coupled to the second solar panel. The input AC power 112 may also be AC power generated by an AC power generator, AC power inverter, and/or any other type of AC power source independent from the solar panel 300 that will be apparent to those skilled in the relevant art(s) without departing from the spirit and scope of the disclosure.

[0052] The AC inlet receptacle 330 may include a male configuration or a female configuration. In an embodiment, the AC inlet receptacle 330 may include a male configuration so that an individual cannot mistakenly plug an electronic device into the AC inlet receptacle with the intent to power the electronic device. Typically, electronic devices include plugs in male configurations. The AC inlet receptacle 330 may be fused protected. The AC inlet receptacle 330 may be configured to receive the input AC power 112 in American, European, and/or any other power format that will be apparent to those skilled in the relevant art(s) without departing from the spirit and scope of the disclosure. The AC inlet receptacle 330 may include an Edison plug, any of the several International Electrotechnical Commission (IEC) plugs and/or any other type of plug that will be apparent to those skilled in the relevant art(s) without departing from the spirit and scope of the disclosure.

[0053] The AC inlet receptacle 330 may provide received input AC power 315 to a power signal sensor 340. The power signal sensor 340 may sense the solar panel 300 is receiving the input AC power 112 through the AC inlet receptacle 330 based on the received input AC power 315 received from the AC inlet receptacle 330. After the power signal sensor 340 senses the received input AC power 315, the power signal sensor 340 generates an incoming AC power signal 325. The incoming AC power signal 325 provides information regarding power signal characteristics of the input AC power 112 that the solar panel 300 is receiving through the AC inlet receptacle 330. The incoming AC power signal 325 may provide information regarding power signal characteristics of the input AC power 112 that includes but is not limited to frequency, phase, amplitude, current, voltage and/or any other characteristic of a power signal that will be apparent to those skilled in the relevant art(s) without departing from the spirit and scope of the disclosure.

[0054] The power signal sensor 340 provides the incoming AC power signal 325 to a power signal synchronizer 350. The power signal synchronizer 350 determines the power signal characteristics of the input AC power 112 that are provided by the incoming AC power signal 325. For example, the power signal synchronizer 350 determines the frequency, phase, amplitude, voltage and/or current of the input AC power 112. The power signal synchronizer 350 generates a synchronized input power signal 335 that provides the power signal characteristics of the input AC power 112 to a controller 360. In an embodiment, the power signal synchronizer 350 determines the power signal characteristics of the input AC power 112 by monitoring the voltage of the incoming AC power signal 325.

[0055] The power signal synchronizer 350 also synchronizes the converted AC power 367 that is generated by the DC to AC converter 370 with the power signal characteristics of the input AC power 112. The output AC power 195 includes the input AC power 112 in parallel with the converted AC power 367 when the converted AC power 367 is synchronized with the input AC power 112. For example, the power signal synchronizer 350 synchronizes the converted AC power 367 to operate at a substantially equivalent frequency, phase, amplitude, voltage and/or current of the input AC power 112. In an embodiment, the input AC power 112 embodies a substantially pure sinusoidal waveform. The substantially pure sinusoidal wave may represent an analog audio wave with is substantially smooth and curved rather than a digital audio wave that includes squared off edges. In such an embodiment, the power signal synchronizer 350 synchronizes the converted AC power 367 to be substantially equivalent to the pure sinusoidal wave embodied by the input AC power 112. After the power signal synchronizer 350 synchronizes the converted AC power 367 to the power signal characteristics of the input AC power 112, the power signal synchronizer 350 notifies the controller 360 of the synchronization via the synchronized input power signal 335.

[0056] The controller 360 receives the synchronized input power signal 335. The controller 360 determines the power signal characteristics of the input AC power 112 and then stores the power signal characteristics in a memory included in the controller 360. For example, the controller 360 stores the frequency, phase, amplitude, voltage and/or current of the input AC power 112. After receiving the synchronized input power signal

335, the controller 360 is aware that the input AC power 112 is coupled to the AC inlet receptacle 330. In response to the input AC power 112 coupled to the AC inlet receptacle 330, the controller 360 stops generating the reference clock for the solar panel 300.

[0057] Also, in response to the input AC power 112 coupled to the AC inlet receptacle 330, the controller 360 also generates a battery bank signal 345. The controller 360 instructs the battery bank 320 via the battery bank signal 345 to no longer provide stored DC power 355 to the DC to AC inverter 370. The instruction by the controller 360 to the battery bank 320 to no longer provide stored DC power 355 to the DC to AC inverter 370 also terminates the standalone output AC power 195 that is generated from the stored DC power 355.

[0058] Further, in response to the input AC power 112 coupled to the AC inlet receptacle 330, the controller 360 confirms that the power signal synchronizer 350 has synchronized the converted AC power 367 to the power signal characteristics of the input AC power 112. After confirming that the power signal synchronizer 350 has synchronized the converted AC power 367 to the power signal characteristics of the input AC power 112, the controller 360 links in parallel the input AC power 112 being received by the AC inlet receptacle 330 with the converted AC power 367 to the AC outlet receptacle 390 to generate the parallel AC power 395. The AC outlet receptacle 390 then outputs the output AC power 195 that includes the input AC power 112 in parallel with the converted AC power 367 with power signal characteristics that are substantially equivalent to the power signal characteristics of the input AC power 112. For example, the frequency, phase, amplitude, voltage and/or current of the output AC power 195 may be substantially equivalent to the frequency, phase, amplitude, voltage and/or current of the input AC power 112.

[0059] The AC outlet receptacle 390 may include a male configuration or a female configuration. In an embodiment, the AC outlet receptacle 390 may include a female configuration so that an individual can easily plug an electronic device into the AC outlet receptacle 390 with the intent to power the electronic device. Typically, electronic devices include plugs in male configurations. In another embodiment, the AC outlet receptacle 390 may include a configuration that is opposite that of the AC inlet receptacle

330. For example, the AC inlet receptacle 330 may include a male configuration while the AC outlet receptacle 390 includes a female configuration.

[0060] The AC outlet receptacle 390 may be fused protected. The AC outlet receptacle 390 may be configured to provide the output AC power 390 in American, European, and/or any other power format that will be apparent to those skilled in the relevant art(s) without departing from the spirit and scope of the disclosure. The AC outlet receptacle 390 may include an Edison plug, any of the several International Electrotechnical Commission (IEC) plugs and/or any other type of plug that will be apparent to those skilled in the relevant art(s) without departing from the spirit and scope of the disclosure.

[0061] As noted above, the solar panel 300 may automatically transition between the master and/or slave designations without user intervention. The solar panel 300 may automatically transition from operating as a slave to operating as a master when the AC input power signal 112 diminishes and is no longer received by the AC inlet receptacle 330. The controller 360 no longer receives the synchronized input power signal 335 providing information regarding the AC input power 112. At that point, the controller 360 generates the battery bank signal 345 to instruct the battery bank 320 to begin generating the stored DC power 355. The controller 360 generates a power conversion signal 365 to instruct the DC to AC converter 370 to convert the stored DC power 355 to converted AC power 367. The converted AC power 367 is high-voltage AC output power. In an embodiment, the DC to AC converter 370 may use high frequency modulation in converting the stored DC power 355 to the converted AC power 367.

[0062] The controller 360 then provides a synchronized output power signal 385 to the power signal synchronizer 380. The synchronized output power signal 385 provides the power signal characteristics of the input AC power 112 when the input power signal 112 was coupled to the AC inlet receptacle 330 to the power signal synchronizer 380. For example, the synchronized output power signal 385 provides the frequency, phase, amplitude, voltage and/or current of the input power signal 112 to the power signal synchronizer 380. The synchronized output power signal 385 also provides a reference clock to the power signal synchronizer 380.

[0063] The power signal synchronizer 380 then generates synchronized AC output power 375 by synchronizing the converted AC power 367 to the power signal characteristics of

the input AC power 112 and the reference clock provided by the synchronized output power signal 385. In an embodiment, the input AC power 112 embodies a substantially pure sinusoidal waveform. In such an embodiment, the power signal synchronizer 380 synchronizes the converted AC power 367 to be substantially equivalent to the pure sinusoidal wave embodied by the input AC power 112. The synchronized AC output power 375 includes power signal characteristics that are substantially equivalent to the power signal characteristics of the input AC power 112. For example, the synchronized AC output power 357 includes a frequency, phase, amplitude, voltage and/or current that is substantially equivalent to the frequency, phase, amplitude, voltage and/or current of the input AC power 112. The AC outlet receptacle 390 then generates the standalone output AC power 195 based on the synchronized output power 375. The standalone output includes the input AC power 112 in parallel with the synchronized AC output power 375. Thus, the solar panel 300 generates the standalone output AC power 195 that is substantially similar to the input AC power 112 despite not being grid tied and/or receiving the input AC power 112 from other sources.

A THIRD EXEMPLARY SOLAR PANEL

[0064] FIG. 4 is a block diagram of a third exemplary solar panel 400 that may be used in the solar panel configuration 200 according to an exemplary embodiment of the present disclosure. Although, FIG. 4 depicts a block diagram of the solar panel 400, one of ordinary skill in the art will recognize that FIG. 4 may also depict a block diagram of the plurality of panels 100a through 100n used in the solar panel configuration 200 depicted in FIG. 2 and also the solar panel 100 depicted in FIG. 1. One of ordinary skill in the art will also recognize that features depicted in the block diagram of the solar panel 300 may also be included in the solar panel 400 but have been omitted for clarity.

[0065] The solar panel 400 may automatically transition from operating as a master and operating as a slave without user intervention based on a relay configuration. The transitioning of the relay configuration may automatically transition the solar panel 400 between operating as a master and operating as a slave without user intervention. The solar panel 400 may be implemented using the solar power collector 310, the battery bank 320, the AC inlet receptacle 330, the controller 360, the DC to AC converter 370, the AC outlet receptacle 390, a first relay 410 and a second relay 420. Each of which are

enclosed within a housing for the solar panel 400. The solar panel 400 shares many similar features with the solar panel 100, the plurality of solar panels 100a through 100n, and the solar panel 300; therefore, only the differences between the solar panel 400 and the solar panel 100, the plurality of solar panels 100a through 100n, and the solar panel 300 are to be discussed in further detail.

[0066] As noted above, the solar panel 400 operates as a slave when the controller 360 senses that the input AC power 112 is coupled to the AC inlet receptacle 330. The controller then terminates the generation of the standalone output AC power 195. The solar panel 400 operates as a master when the controller 360 no longer senses that the input AC power 112 is coupled to the AC inlet receptacle 330. The controller 360 then instructs the battery bank 320 and the DC to AC inverter 370 to begin generating the standalone output AC power 195. The relay configuration that includes a first relay 410 and a second relay 420 transitions the solar panel 400 between the master and slave modes based on the logic provided in Table 1.

Master Mode	Relay 1 Open	Relay 2 Closed
Slave Mode	Relay 1 Closed	Relay 2 Closed
Unit Power Off (Bypassed)	Relay 1 Closed	Relay 2 Open

Table 1

[0067] When automatically transitioning from the slave mode to the master mode, the controller 360 no longer senses the input AC power 112 coupled to the AC inlet receptacle 330. At this point, the controller 360 generates a first relay signal 450 that instructs the first relay 410 transition to the open state (logic 0). The controller 360 also generates a second relay signal 460 that instructs the second relay 420 to transition to the closed state (logic 1). The controller 360 also generates battery bank signal 345 that instructs the battery bank 320 to begin providing the stored DC power 355 to the DC to AC converter 370 to generate the converted AC power 367. Because the second relay 420 is in the closed position (logic 1), the converted AC power 367 passes through the second relay 420 onto the AC outlet receptacle 390 so that the solar panel 400 provides the AC output power 195 generated from the stored DC power 355 rather than the input AC power 112. The open state (logic 0) of the first relay 410 prevents any remaining

input AC power 112 from reaching the AC output receptacle 390 when the solar panel 400 is generating the standalone AC output power 195 as operating as the master.

[0068] Once the controller 360 senses the input AC power 112 coupled to the AC inlet receptacle 330, the controller 360 automatically generates the battery bank signal 345 to instruct the battery bank 320 to no longer provide the stored DC power 355 so that the solar panel 400 no longer generates the standalone AC output power 195. The controller 360 also automatically generates the second relay signal 460 to instruct the second relay 420 to transition to the open state (logic 0). The controller 360 also generates the first relay signal 450 to instruct the first relay 410 to transition to the closed state (logic 1). After the second relay 420 transitions to the open state (logic 0) and the first relay 410 transitions to the closed state (logic 1), any input AC power 112 coupled to the AC inlet receptacle 330 passes through the solar panel 400 to the AC outlet receptacle 390 so that the solar panel 400 generates the output AC power 195 that is substantially equivalent to the input AC power 112.

[0069] However, the second relay 420 is still in the open state (logic 0). The controller 360 is not going to instruct the second relay 420 to transition into the closed state (logic 1) until the controller 360 has successfully synchronized the solar panel 400 to the input AC power 112 coupled to the AC inlet receptacle 330. After the controller 360 properly synchronizes solar panel 400 to the input AC power 112, then the controller 360 generates the second relay signal 460 to instruct the second relay 420 to transition from the open state (logic 0) to the closed state (logic 1). After the second relay 420 transitions from the open state (logic 0) to the closed state (logic 1), then the solar panel 400 is generating output AC power 195 that includes the converted AC power 367 that is in parallel to the input AC power 112.

[0070] The solar panel 400 also operates in a bypass mode. In the bypass mode, the solar panel 400 is powered off and is no longer functioning. In embodiment, the controller 360 generates the first relay signal 450 and instructs the first relay 410 to transition into the closed state (logic 1). The controller 360 also generates the second relay signal 460 and instructs the second relay 420 to transition into the open state (logic 0). In another embodiment, the first relay 410 and the second relay 420 are spring loaded relay switches. When the solar panel 400 powers off, the electromagnetic coil of the first relay

410 is no longer energized so the spring pulls the contacts in the first relay 410 into the up position. The closing of the first relay 410 and the opening of the second relay 420 causes the solar panel 400 to be a pass through where the input AC power 112 passes through the solar panel 400 and onto a second solar panel daisy chained to the solar panel 400 and/or to an electronic device being powered by the input AC power 112. Thus, additional solar panels and/or electronic devices down the line from the dysfunctional solar panel 400 continue to operate off of the input AC power 112. The first relay 410 and the second relay 420 may be implemented may be implemented in hardware, firmware, software, or any combination thereof that will be apparent to those skilled in the relevant art(s) without departing from the spirit and scope of the disclosure.

A FOURTH EXEMPLARY SOLAR PANEL

[0071] FIG. 5 is a block diagram of a fourth exemplary solar panel 500 that may be used in the solar panel configuration 200 according to an exemplary embodiment of the present disclosure. Although, FIG. 5 depicts a block diagram of the solar panel 500, one of ordinary skill in the art will recognize that FIG. 5 may also depict a block diagram of the plurality of panels 100a through 100n used in the solar panel configuration 200 depicted in FIG. 2, and the solar panel 100 depicted in FIG. 1. One of ordinary skill in the art will also recognize that features depicted in the block diagram of the solar panel 300 and 400 may also be included in the solar panel 500 but have been omitted for clarity.

[0072] The solar panel 500 may be implemented using the solar power collector 310, a battery charge circuit 510, a current amplifier 512, the battery bank 320, a battery balancer protection circuit 520, a step transformer 530, a location module 540, an AC voltage step down transformer DC output, a wireless data transmitter and receiver 560, a thermal protection module 570, an integrated light source module 580, an AC frequency correction and filter circuit 590, a protection circuit 515, the AC inlet receptacle 330, the controller 360, the DC to AC converter 370, a frequency, amplitude, phase detection synchronizer and frequency multiplexing transceiver 525, a 50 or 60 Hertz (Hz) true sine wave generator 535, a cooling fan 545, a protection circuit 565, an AC power coupling switch 555 and the AC outlet receptacle 390. Each of which are enclosed within a housing for the solar panel 500. The solar panel 500 shares many similar features with

the solar panel 100, the plurality of solar panels 100a through 100n, the solar panel 300, and the solar panel 400; therefore, only the differences between the solar panel 500 and the solar panel 100, the plurality of solar panels 100a through 100n, the solar panel 300, and the solar panel 400 are to be discussed in further detail.

[0073] The battery charge circuit 510 may include passive and/or active circuitry as well as integrated circuits to control and/or regulate the charging of the battery bank 320 included within the solar panel 500. The battery charge circuit 510 may have bidirectional communication with a computing device, such as controller 360. The controller 360 may also control the battery charge circuit 510. The current amplifier 512 may increase the output current of the solar panel and assist in charging the battery bank 320.

[0074] The battery balancer protection circuit 520 is disposed within the housing of the solar panel 500. The battery balancer protection circuit 520 may include passive and/or active circuitry as well as integrated circuits that may be controlled by the controller 360. The battery balancer protection circuit 520 may be used to ensure safe discharge and recharge of the individual cells within the battery bank 320.

[0075] The solar panel 500 may further include a location module 540. The location module 540 may include one or several location sensors such as but not limited to a global positioning system (GPS), a compass, a gyroscope, an altitude, and/or any other location sensor digital media file that will be apparent to those skilled in the relevant art(s) without departing from the spirit and scope of the disclosure. The location module 540 may be used to send data to the controller 360 through the wireless data transmitter and receiver 560 to an external personal computing device.

[0076] The AC voltage step down transformer 550 is included in the solar panel 500. The step down transformer 550 may be used to charge the battery bank 320 from the AC inlet receptacle 330 through the battery charge circuit 510. The step down transformer 550 may include iron, steel, ferrite or any other materials and fashioned specifically to satisfy power requirements for charging the battery bank 320. The step down transformer 550 may also have a filtered DC output.

[0077] As discussed above, the solar panel 500 includes a computing device such as the controller 360. The controller 360 may be used to control and/or monitor the solar panel

500. The controller 360 may be a single or multiple processor based and may be able to receive software and/or firmware updates wirelessly through the associated wireless data transmitter and receiver 560 or through a hardware connection such as the frequency multiplexing transceiver 525. The controller 360 may be connected to any part of the solar panel 500 for central control, remote control, general monitoring, and/or data collection purposes. The wireless data transmitter and receiver 560 may use Bluetooth, Wi-Fi, cellular, and/or any other acceptable radio frequency data transmissions and reception techniques that will be apparent to those skilled in the relevant art(s) without departing from the spirit and scope of the disclosure. The transmitter and receiver 560 may be used to transmit data from the solar panel 500 to one or more external personal computing devices.

[0078] The solar panel 500 includes a thermal protection module 570. The thermal protection module 570 includes one or more sensors positioned in one or more locations throughout any part of the solar panel 500 for the purpose of temperature monitoring. The thermal protection module 570 is connected to the controller 360 and may be used to transmit data from the solar panel 500 to external personal computing devices.

[0079] As shown, the solar panel 500 may include the integrated light source 580. The integrated light source 580 may include one or more integrated lights inside or disposed on an exterior surface of the housing of the solar panel 500 and may be used as a light source. The integrated lights may vary in color, intensity, color temperature size, frequency, and/or brightness. The integrated light source 580 may be coupled to the controller 360. The integrated light source 580 may be used to transmit data from the solar panel 500 to external personal computing devices.

[0080] The solar panel 500 further includes a grid frequency, amplitude, power phase detection synchronizer and frequency multiplexing transceiver 525, which may synchronize multiple AC power sources and transmit data between one or more solar panels 500 via a standard AC power line.

[0081] The solar panel 500 further includes a frequency generator, such as a true sine wave generator 535, such as a 50 Hz or 60 Hz true sine wave generator 535. The frequency generator may be other types of generators configured to output a signal at a particular reference frequency. The sine wave generator 535 may provide a sine wave

reference to the DC to AC converter 370. The sine wave generator 535 may be coupled to the controller 360 as well as the grid frequency, amplitude, power phase detection synchronizer and frequency multiplexing transceiver 525. Moreover, the sine wave generator 535 may include analog and/or digital circuitry.

[0082] The solar panel 500 may further include a cooling fan 545 disposed within the housing of the solar panel 500. The cooling fan 545 may include one or more cooling fans arranged in a way that best ventilates an interior at least partially formed by the housing of the solar panel 500 in which one or more components are disposed. The cooling fan 545 may be coupled to the thermal protection module 570 and/or the controller 360.

[0083] Furthermore, the solar panel 500 includes an AC frequency correction and filter circuit 590. The frequency correction and filter circuit 590 may be controlled by the controller 360 through the 50 Hz or 60 Hz true sine wave generator 535. In addition, the frequency correction and filter circuit 590 may receive AC power from the step up transformer 530 and may output corrected and filtered AC power to a protection circuit 515 of the solar panel 500. The protection circuit 515 provides surge and fuse protection and may be controlled and monitored by the controller 360.

[0084] Moreover, the solar panel 500 includes an AC coupling switch 555 that is configured to couple the AC power from the AC inlet receptacle 330 with AC grid equivalent power generated by the solar panel 500 such that synchronized AC power from the AC inlet receptacle 330 and the solar panel 500 are coupled together for output from the AC outlet receptacle 390. The AC coupling switch 555 may be controlled by the controller 360 in conjunction with the grid frequency, amplitude, power phase detection synchronizer and frequency multiplexing transceiver 525.

A SECOND EXEMPLARY SOLAR PANEL CONFIGURATION

[0085] FIG. 6 illustrates a block diagram of a second exemplary solar panel configuration according to an exemplary embodiment of the present disclosure. The solar panel configuration 600 represents a solar panel configuration that includes a plurality of solar panels 610a through 610n that may be daisy chained together and coupled to a grid tie system 640 to form the solar panel configuration 600, where n is an integer greater than or equal to one. The grid tie system 640 monitors the input AC power 112 that is

generated by the grid to determine whether the power grid remains stable to generate the input AC power 112. The grid tie system 640 instructs the battery bank 620 to provide converted AC power 660 to the plurality of solar panels 610a through 610n when the grid tie system 640 determines that the power grid has failed. Thus, the grid system 640 provides back up power to the plurality of solar panels 610a through 610n when the grid fails.

[0086] The grid system 640 includes the battery bank 620, a relay switch 630, a DC to AC converter 680 and a power signal sensor 650. The solar panel configuration 600 shares many similar features with the solar panel 100, the plurality of solar panels 100a through 100n, the solar panel 300, the solar panel 400, the solar panel 500, and the solar panel configuration 200; therefore, only the differences between the solar panel configuration 600 and the solar panel 100, the plurality of solar panels 100a through 100n, the solar panel 300, the solar panel 400, the solar panel 500, and the solar panel configuration 200 are to be discussed in further detail.

[0087] In an embodiment, the plurality of solar panels 610a through 610n may include larger solar panels with larger capacities to capture solar energy and convert the captured solar energy into DC power that may be stored in the battery bank 620. The grid tie system 640 may automatically link the plurality of solar panels 610a through 610n to the input AC power 112 when the grid tie system 640 is grid tied. The grid tie system 640 may also automatically provide the converted AC power 660 to the plurality of solar panels 610a through 610n when the grid tie system 640 is no longer grid tied such that the input AC power 112 is no longer available to the plurality of solar panels 610a through 610n.

[0088] In an embodiment, the each of the plurality of solar panels 610a through 610n may be updated as to the status of the grid. For example, the plurality of solar panels 610a through 610n may be updated when the grid fails via a signal that is transmitted through the AC power line of the grid.

[0089] In another embodiment, the grid tie system 640 may control the converted AC power 660 so that the DC power stored in the battery bank 620 is not depleted from the use of the converted AC power 660. For example, the grid tie system 640 may dial back

the use of the converted AC power 660 from maximum capacity to conserve the DC power stored in the battery bank 620

[0090] The grid tie system 640 includes a relay switch 630. The relay switch 630 transitions into an open state (logic 0) when the grid fails and is no longer providing the input AC power 112 to the grid tie system 640 so that the grid tie system 640 may be substantially disconnected from the grid. The grid tie system 640 immediately instructs the DC to AC converter 680 to convert the DC power stored in the battery bank 620 to begin providing the converted AC power 660 the plurality of solar panels 610a through 610n to replace the input AC power 112 no longer supplied to the grid tie system 640. The converted AC power 660 may include power signal characteristics that have already been synchronized with the power signal characteristics included in the input AC power 112 before the grid went down. For example, the converted AC power 660 may include a frequency, phase, amplitude, voltage and/or current that are substantially similar to the frequency, phase, amplitude, voltage and/or current of the input AC power 112. As a result, the plurality of solar panels 610a through 610n fail to recognize that the grid has failed and is no longer providing the input AC power 112 to the grid tie system 640.

[0091] After the grid fails, the power signal sensor 650 continues to sense the power signal characteristics on the failed side of the relay switch 630. For example, the power signal sensor 650 continues to sense the voltage, current, frequency, and/or phase on the failed side of the relay switch 630. As the grid begins to come back up, the power signal sensor 650 recognizes that the power signal characteristics on the failed side of the relay switch 630 are beginning to show that the grid is coming back up. As the grid stabilizes, the grid tie system 640 begins to adjust the power signal characteristics of the converted AC power 660 to become substantially equivalent to the power signal characteristics of the input AC power 112 being sensed by the power signal sensor 650. For example, the grid tie system 640 synchronizes the converted AC power 660 so that the frequency, phase, amplitude, voltage and/or current of the converted AC power 660 becomes substantially equivalent to the frequency, phase, amplitude, voltage and/or current of the input AC power 112 being sensed by the power signal sensor 650.

[0092] After the power signal characteristics of the converted AC power 660 are substantially equivalent to the power signal characteristics of the input AC power 112,

the grid tie system 640 transitions the relay switch 630 into a closed position (logic 1). The plurality of solar panels 610a through 610n are no longer running off of the converted AC power 660 but are rather running off of the input AC power 112 provided by the grid.

A WIRELESS SOLAR PANEL CONFIGURATION

- [0093] FIG. 7 shows an illustration of a wireless solar panel configuration 700. The wireless solar panel configuration 700 includes a client 710, a network 720, and a solar panel 730.
- [0094] One or more clients 710 may connect to one or more solar panels 730 via network 720. The client 710 may be a device that includes at least one processor, at least one memory, and at least one network interface. For example, the client may be implemented on a personal computer, handheld computer, personal digital assistant, smart phone, a mobile telephone, a game console, a set-top box, and the like.
- [0095] In an embodiment, the client 710 may communicate with the solar panel 730 via network 720. Network 720 includes one or more networks, such as the Internet. In some embodiments of the present invention, network 720 may include one or more wide area networks (WAN) or local area networks (LAN). Network 720 may utilize one or more network technologies such as Ethernet, Fast Ethernet, Gigabit Ethernet, virtual private network (VPN), remote VPN access, a variant of IEEE 802.11 standard such as Wi-Fi, and the like. Communication over network 720 takes place using one or more network communication protocols including reliable streaming protocols such as transmission control protocol (TCP). These examples are illustrative and not intended to limit the present invention.
- [0096] The solar panel 730 includes the controller 360. The controller 360 may be any type of processing (or computing device) as described above. For example, the controller 360 may be a workstation, mobile device, computer, cluster of computers, set-top box, or other computing device. In an embodiment, multiple modules may be implemented on the same computing device. Such a computing device may include software, firmware, hardware, or a combination thereof. Software may include one or more application on an operating system. Hardware can include, but is not limited to, a processor, memory, and/or graphical user interface display.

[0097] In an embodiment, the client 710 may communicate with the solar panel 730 via network 720 to instruct the solar panel 730 as to the appropriate actions to take based on the time of the day. For example, the client 710 may communicate with the solar panel 730 to instruct solar panel 730 to charge its batteries via the input AC power provided by the grid during times of the day in when the sunlight is not acceptable. In another example, the client 710 may communicate with the solar panel 730 via network 720 to instruct the solar panel 730 operate off of the DC power provided by the internal batteries included in the solar panel 730 during peak utility hours. In such an example, the client 710 may communicate with the solar panel 730 to charge its internal batteries from the solar energy captured by the solar panel 730 during off peak hours while the solar panel 730 relies on the input AC power provided by the grid. Then the client 710 may communicate with the solar panel 730 run off of its charged internal batteries during peak hours when the grid is stressed. In another embodiment, the client 710 may communicate with the solar panel 730 via network 720 to receive status updates of the solar panel 730.

[0098] In an embodiment, the solar panel 730 may include a GPS. The client 710 may communicate with the solar panel 730 via network 720 adjust the solar panel 730 to so that the solar panel 730 may face the sun at an angle that maximizes the solar energy captured by the solar panel 730. The client 710 may analyze the GPS coordinates of the solar panel 730 provided to the client 710 via the network 720. Based on the GPS coordinates of the solar panel 730 provided to the client 710, the client may adjust the solar panel 730 to face the sun at an angle that maximizes the solar energy captured by the solar panel 730.

[0099] In an embodiment, the solar panel 730 includes a tilt mechanism that is built into the back of the solar panel 730. The tilt mechanism may include a stepper motor that adjusts the solar panel 730 at an angle to face the sun that maximizes the solar energy captured by the solar panel 730 as the client 710 adjusts the solar panel 730 based on the GPS coordinates of the solar panel 730.

[00100] In an embodiment, the client 710 may remotely control the output AC power of the solar panel 730 via the network 720. The client 710 may dial back the output AC power of the solar panel 730 so that the DC power stored in the battery bank of the solar panel 730 is not depleted.

[00101] In an embodiment, the client 710 may obtain information regarding the solar panel 730 via the network 720 that may include but not limited to energy produced by the solar panel 730, energy consumed by the solar panel 730, the tilt of the solar panel 730, the angle of the solar panel 730, the GPS coordinates of the solar panel 730 and/or any other information regarding the solar panel 730 that may be communicated to the client 710 via the network 720 that will be apparent to those skilled in the relevant art(s) without departing from the spirit and scope of the disclosure.

AN EXEMPLARY OPERATIONAL CONTROL FLOW OF THE SOLAR PANEL

[00102] FIG. 8 is a flowchart of exemplary operational steps of the solar panel according to an exemplary embodiment of the present disclosure. The present disclosure is not limited to this operational description. Rather, it will be apparent to persons skilled in the relevant art(s) from the teachings herein that other operational control flows are within the scope and spirit of the present disclosure. The following discussion describes the steps in FIG. 8

[00103] At step 810, the operational control flow collects solar energy from a solar source.

[00104] At step 820, the operational control flow converts the solar energy into direct current (DC) power. Specifically, the operational control flow converts the solar energy captured by a solar panel collector, such as the solar panel collector 310 to provide an example, into the DC power, such as converted DC power 305 to provide an example.

[00105] At step 830, the operational control flow stores the DC power.

[00106] At step 840, the operational control flow receives input AC power generated from an AC power source external to the solar panel. For example, the operational control flow receives input AC power 112 via the inlet AC receptacle 112 where the AC power 112 is generated by the grid.

[00107] At step 850, the operational control flow detects when the input AC power is coupled to the AC inlet receptacle.

[00108] At step 860, the operational control flow automatically generates standalone output AC power for the solar panel that is in parallel to the input AC power when the input AC power is coupled to the AC inlet receptacle.

A FIRST EXEMPLARY SOLAR PANEL CONNECTOR CONFIGURATION

[00109] FIG. 9 illustrates a block diagram of a solar panel connector configuration according to an exemplary embodiment of the present disclosure. The solar panel connector configuration 900 represents a solar panel connector configuration that includes a plurality of solar panels 100(a-n) that may be daisy chained together to form the solar panel connector configuration 900, where n is an integer greater than or equal to two. Each solar panel 100(a-n) that is added to the solar panel connector configuration 900 may generate the output AC power 195n that is in parallel with the output AC power 195a and the output AC power 195b of the solar panel connector configuration 900. Each solar panel 100(a-n) may be connected to each other via a plurality of solar panel connectors 910(a-n) where n is an integer greater than or equal to one. Each solar panel connector 910(a-n) transitions the output AC power 195(a-n) from the output of each respective solar panel 100(a-n) to the input of each respective solar panel 100(b-n). For example, the solar panel connector 910a transitions the output AC power 195a from the output of solar panel 100a to the input of solar panel 100b and the solar panel connector 910n transitions the output AC power 195b from the output of solar panel 100b to the input of solar panel 100n. An end cable 920 receives the output AC power 195n from the final solar panel 100n in the solar panel connector configuration 900.

[00110] Conventional solar panel configurations include solar panels that are daisy chained together by numerous conventional wires connecting each solar panel. The numerous conventional wires are required to properly daisy chain the power generated by each solar panel to provide an output power. The numerous conventional wires are also required for data communication between each solar panel. The numerous conventional wires are typically tie wrapped and are positioned strategically between solar panels.

[00111] The numerous conventional wires required to conventionally daisy chain solar panels together in the conventional solar panel configurations add unnecessary difficulty in the installation process for the solar panels. The added difficulty includes an increase in the burden required in the installation of the solar panels due to the additional effort required to properly connect each of the solar panels together. The numerous conventional wires are to be properly positioned so that structural stress does not occur on the structure supporting the conventional solar panel configuration, the solar panels,

and/or the wires themselves resulting in damage. Additional time is also unnecessarily required during installation to properly install the solar panels. Installers of the solar panels have to properly position each of the numerous conventional wires and tie wrap the numerous conventional wires for each solar panel included in the daisy chain to potentially minimize the risk of any damage that may result from the numerous conventional wires. The additional time spent to position the numerous conventional wires is significant and adds to the time required to complete the installation process using the numerous conventional wires.

[00112] The numerous conventional wires are also a safety hazard. Structural failures occur when the numerous conventional wires are not properly positioned. For example, the structure supporting the daisy chain of solar panels structurally fails causing damage and/or injury when the weight of the numerous conventional wires is not properly distributed. Electrical damage also occurs when the numerous conventional wires are not properly positioned. The electrical damage occurs due to the structural stress on the numerous conventional wires and/or from improperly positioning the numerous conventional wires resulting in an electrical reaction between two or more conventional wires.

[00113] The numerous conventional wires also hinder the overall efficiency of the conventional daisy chained solar panel configuration. The routing of power through the numerous conventional wires decreases the overall power efficiency because power is lost through the routing of power through the numerous conventional wires. The numerous conventional wires also hinder mobility in moving the conventional daisy chained solar panel configuration. The difficulty that results from properly positioning the numerous conventional wires deters installers from disassembling the solar panels and then reassembling the solar panels in a conventional daisy chain configuration with the numerous conventional wires in a different location.

[00114] The solar panel connectors 910(a-n) eliminates the need for the numerous conventional wires to daisy chain the solar panels 100(a-n) together. The solar panel connectors 910(a-n) simplify the connection of the solar panels 100(a-n) to a three conductor configuration. The solar panel connectors 910(a-n) properly daisy chain the output AC power 195(a-n) to properly parallel the output power 195a and 195b to the

output AC power 195n. The solar panel connectors 910(a-n) may also provide data communication between each of the solar panels 100(a-n).

[00115] The simplification of the connection of the solar panels 100(a-n) from numerous conventional wires to a single three conductor configuration embodied in the solar panel connectors 910(a-n) eliminates the burden required in installing the solar panels 100(a-n). Rather than having to address the structural issues that result from positioning the numerous conventional wires, simply a single solar panel connector 910(a-n) is required to connect each solar panel 100(a-n) eliminating the need for numerous conventional wires. Eliminating the numerous conventional wires eliminates the structural issues associated with the conventional daisy chain configuration. The single solar panel connector 910(a-n) does not have a structural burden on the conventional daisy chain configuration. Further, the time required during installation using the three conductor configuration of the solar panel connectors 910(a-n) is also minimized. No longer does the installer have to spend significant time properly positioning the numerous conventional wires and tie wrapping the numerous conventional wires to minimize the structural burden placed on the conventional daisy chain configuration from the numerous conventional wires. The simplicity of the single solar panel connector 910(a) used to connect two solar panels 100a and 100b requires that the installer plug in the solar panel connector 910(a) into the output of the solar panel 100a and the input of the solar panel 100b.

[00116] The three conductor configuration of the solar panel connectors 910(a-n) also improves the safety of the solar panel connector configuration 900. With the need for the numerous conventional wires eliminated, the risk associated with electrical damage that occurs with the improper positioning of the numerous conventional wires is significantly lowered. The three conductor configuration of the solar panel connectors 910(a-n) eliminates the electrical damage that may have resulted from the structural damage caused by the numerous conventional wires. The three conductor configuration also eliminates the electrical damage that may have resulted from the improper positioning of the numerous conventional wires.

[00117] The three conductor configuration of the solar panel connectors 910(a-n) also improves the overall efficiency of the solar panel connector configuration 900. The

simplification of the numerous conventional wires to the three conductor configuration of the solar panel connectors 910(a-n) decreases the amount of wires required to transfer the power from solar panel to solar panel which decreases the amount of power that is lost during the transfer. The power efficiency may be optimized with the three conductor configuration of the solar panel connector 910(a-n) due to the minimizing of the connection to a three conductor configuration provided by a single connector.

[00118] The three conductor configuration of the solar panel connectors 910(a-n) also provides mobility to the solar panel connector configuration 900. Due to the ease of simply installing each solar panel connector 910(a-n) between each respective solar panel 100(a-n), installers may be much more inclined to disassemble the solar panel connector configuration 900 and move the solar panel connector configuration 900 to a different location. Reassembling the solar panel connector configuration 900 in the different location simply requires the installation of the solar panel connectors 910(a-n) between each respective solar panel 100(a-n) providing ease in mobility.

[00119] The three conductor configuration of the solar panel connectors 910(a-n) may be compatible connecting AC power to AC power as in connecting output AC power 195a from solar panel 100a to solar panel 100b and connecting output AC power 195b from solar panel 100b to solar panel 100n. However, the three conductor configuration of the solar panel connectors 910(a-n) may also be capable of connecting DC power to DC power without any additional modifications to the solar panel connectors 910(a-n). The three conductor configuration of the solar panel connectors 910(a-n) may also provide data communication between the solar panels 100(a-n). For example, the three conductor configuration may support power line modem technology data communication between the solar panels 100(a-n). The three conductor configuration may support any data communication between the solar panels 100(a-n) that will be apparent to those skilled in the relevant art(s) without departing from the spirit and scope of the disclosure. The compatibility of the solar panel connectors 910(a-n) with both AC power and DC power and also in supporting data communication provides additional simplicity in connecting solar panels.

[00120] For example, as shown in FIG. 9, the solar panel connectors 910(a-n) properly daisy chain the solar panels 100(a-n) to parallel the output AC power 195a and 195b so

that the overall output AC power of the solar panel connector configuration 900 is increased. In daisy chaining the solar panels 100(a-n), the power input for the solar panel 100b is coupled to the power output of the solar panel 100a via the solar panel connector 910a so that the input power AC power 195a received by the solar panel 100b is substantially equivalent to the output AC power 195a of the solar panel 100a. Further, the power input for the solar panel 100n is coupled to a power output of the solar panel 100b via solar panel connector 910n so that the input power AC power 195b received by the solar panel 100n is substantially equivalent to the output AC power 195b of the solar panel 100b.

[00121] After the solar panel connectors 910(a-n) have been properly inserted to electrically connect the solar panels 100(a-n), respectively, the three conductors included in each of the solar panel connectors 910(a-n) engage AC characteristics to electrically connect the AC power transferred between each of the solar panels 100(a-n). A first conductor becomes a hot connection, a second conductor becomes a ground connection, and a third conductor becomes a neutral connection so that the AC power is properly transferred between each of the solar panels 100(a-n). The hot connection, the ground connection, and the neutral connection enable the transfer of the AC power between each of the solar panels 100(a-n) so that the AC power is not degraded and/or decreased during the transfer between the solar panels 100(a-n).

[00122] As noted above, each output AC power 195(a-n) may be paralleled to increase the overall output AC power of the solar panel connector configuration 900. The end cable 920 may be positioned at the output of the final solar panel 100n in the solar panel connector configuration 900 to transfer the overall output AC power represented by the output AC power 195n to a second configuration that requires the overall output AC power. The end cable 920 includes a connector 930 similar to that of the solar panel connectors 910(a-n). The connector 930 includes a three conductor configuration that can accept the output AC power 195n from the solar panel 100n. Cable 940 may be coupled to the connector 930 and also includes a three conductor configuration that can properly transfer the output AC power 195n to a second configuration without any degradation and/or power loss in the output AC power 195n. For example, cable 940 may be coupled to an electric stove so that the paralleled output AC power 195n is

properly transferred by the cable 940 to the electric stove. In another example, cable 940 is coupled to a breaker box so that the solar panel connector configuration 900 is grid tied. Although the solar panel connector configuration 900 depicts three solar panels 100(a-n) that are connected by the solar panel connectors 910(a-n), any quantity of solar panels 100(a-n) may be connected by any quantity of solar panel connectors 910(a-n) in a similar fashion as discussed in detail above that will be apparent to those skilled in the relevant art(s) without departing from the spirit and scope of the disclosure.

A SECOND EXEMPLARY SOLAR PANEL CONNECTOR CONFIGURATION

[00123] FIG. 10 illustrates a block diagram of a solar panel connector configuration according to an exemplary embodiment of the present disclosure. The solar panel connector configuration 1000 represents a solar panel connector configuration that includes the plurality of solar panels 100(a-n) that may be daisy chained together to form the solar panel connector configuration 1000, where n is an integer greater than or equal to two. The solar panel 100a receives input DC power 1070a. As a result, each solar subsequent solar panel 100(b-n) that is added to the solar panel connector configuration 1000 may generate output DC power 1050n that is in parallel with the output DC power 1050a and the output DC power 1050b of the solar panel connector configuration 1000. Each solar panel 100(a-n) may be connected to each other via the plurality of solar panel connectors 910(a-n) where n is an integer greater than or equal to one. Each solar panel connector 910(a-b) transitions the output DC power 1050a and 1050b to the respective input of each respective solar panel 100(b-n). An end cable 920 receives the output DC power 1050n from the final solar panel 100n in the solar panel connector configuration 1000 and transfers the output DC power 1050n to a DC/AC power inverter 1030.

[00124] FIG. 10 is an example implementation of using the solar panel connectors 910(a-n) in an application where the solar panel connectors 910(a-n) transfer output DC power 1050(a-n) that is generated by the solar panels 100(a-n). In daisy chaining the solar panels 100(a-n), the power input for the solar panel 100b is coupled to the power output of the solar panel 100a via the solar panel connector 910a so that the input DC power 1050a received by the solar panel 100b is substantially equivalent to the output DC power 1050a of the solar panel 100a. The power input of the solar panel 100n is coupled to the power output of the solar panel 100b via the solar panel connector 910b so that the input

DC power 1050b received by the solar panel 100n is substantially equivalent to the output DC power 1050b of the solar panel 100b.

[00125] After the solar panel connectors 910(a-b) have been properly inserted to electrically connect the solar panels 100(a-b) and the solar panels 100(b-n), respectively, the three conductors included in each of the solar panel connectors 910(a-b) engage DC characteristics to electrically connect the DC power transferred between each of the solar panels 100(a-n). A first conductor becomes a positive connection, a second conductor becomes a ground connection, and a third conductor becomes a negative connection so that the DC power is properly transferred between each of the solar panels 100(a-n). The positive connection, the ground connection, and the negative connection enable the transfer of the DC power between each of the solar panels 100(a-n) so that the DC power is not degraded and/or decreased during the transfer between the solar panels 100(a-n).

[00126] As noted above, each output DC power 1050(a-n) may be paralleled to increase the overall output DC power of the solar panel connector configuration 1000. The end cable 920 may be positioned at the output of the final solar panel 100n in the DC solar panel connector configuration 1000 to transfer the overall output DC power represented by the output DC power 1050n to the DC/AC power inverter 1030 that converts the overall output DC power to AC power. The cable 940 may be coupled to the solar panel connector 910n that transfers the output DC power 1050n to the DC/AC power inverter 1030. The end cable 920 and the solar panel connector 910n can properly transfer the output DC power 1050n to the DC/AC inverter 1030 without any degradation and/or power loss in the output DC power 1050n.

A THIRD EXEMPLARY SOLAR PANEL CONNECTOR CONFIGURATION

[00127] FIG. 11 illustrates a block diagram of a solar panel connector configuration according to an exemplary embodiment of the present disclosure. The solar panel connector configuration 1100 represents a solar panel connector configuration that includes the plurality of solar panels 100(a-n) that may be daisy chained together in a plurality of rows to form the solar panel connector configuration 1100, where n is an integer greater than or equal to two. The solar panels 100(a-d) are configured in a first row and the solar panels 100(e-n) are configured in a second row. A connect bridge 1120 daisy chains the first row of solar panels 100(a-d) to the second row of solar panels

100(e-n). As a result, the connect bridge 1120 may be used to daisy chain any two rows of solar panels so that multiple connect bridges may be used to daisy chain multiple rows together. As discussed in detail above, the output AC or DC power generated by each solar panel 100(a-n) may be daisy chained in parallel down the line until the output AC or DC power in the last solar panel 100(e) of the solar panel connector configuration 1100 is outputted. An end cable 920 receives the output AC or DC power from the final solar panel 100n in the solar panel connector configuration 1100.

[00128] FIG. 11 is an example implementation of using the connect bridge 1120 in an application where the solar panels 100(a-n) are arranged in multiple rows such as when the solar panels 100(a-n) are positioned on the roof of a house. In daisy chaining the solar panels 100(a-n) in multiple rows, the connect bridge 1120 provides the transition of output AC or DC power between each row of solar panels 100(a-n).

[00129] For example, the solar panel 100d receives input AC power and becomes the master in the solar panel connector configuration 1100. The AC power is then paralleled down the first row of solar panels 100(a-d) via solar panel connectors 910(a-c). However, after the output AC power is generated by the solar panel 100a, the solar panel connector 1130a that is coupled to the output of the solar panel 100a and the cable 1140 of the connect bridge 1120 transfers the output AC power to the solar panel connector 1130b. The solar panel connector 1130b is coupled to the cable 1140 of the connect bridge 1120 and the input of the solar panel 100n. The solar panel connector 1130b then transfers the output AC power of the solar panel 100a to the solar panel 100n so that the output AC power continues to be paralleled through the second row of solar panels 100(e-n). The output AC power generated by the last solar panel 100e in the solar panel connector configuration 1100 is then transferred to the solar panel connector 930 of the end cable 920 and then transferred as discussed in detail above. Further as discussed in detail above, the connect bridge 1120 may also transfer output DC power when DC power is provided by the master solar panel 100d.

AN EXEMPLARY SOLAR PANEL CONNECTOR

[00130] FIG. 12 illustrates an example solar panel connector according to an exemplary embodiment of the present disclosure. The solar panel connector 1200 includes a first conductor enclosure 1210a, a second conductor enclosure 1210b, and a third conductor

enclosure 1210c. The solar panel connector 1200 also includes a first conductor enclosure 1220a, a second conductor enclosure 1220b, and a third conductor enclosure 1220c. A first conductor 1230a is enclosed by the first conductor enclosures 1210a and 1220a. A second conductor 1230b is enclosed by the second conductor enclosures 1210b and 1220b. A third conductor 1230c is enclosed by the third conductor enclosures 1210c and 1220c. A center section 1240 couples the first conductor enclosure 1210a to the first conductor enclosure 1220a, the second conductor enclosure 1210b to the second conductor enclosure 1220b, and the third conductor enclosure 1210c to the third conductor enclosure 1220c. The solar panel connector 1200 is an example embodiment of the solar panel connectors 910a through 910n and shares many similar features with the solar panel connectors 910a through 910n discussed in detail above.

[00131] As noted above, each of the three conductors 1230(a-c) may be configured to act as hot, neutral, and ground when engaged with AC power from a solar panel and also be configured to act as a positive, negative, and ground when engaged with DC power from a solar panel.

[00132] For example, each of the first conductor enclosure 1210a, the second conductor enclosure 1210b, and the third conductor enclosure 1210c may be coupled to a solar panel and receives AC power as discussed above from the solar panel. Upon receiving the AC power, the first conductor 1230a enclosed in the first conductor enclosure 1210a may act as the hot, the second conductor 1230b enclosed in the second conductor enclosure 1210b may act as the ground, and the third conductor 1230c enclosed in the third conductor enclosure 1210c may act as the neutral. The first conductor enclosure 1220a, the second conductor enclosure 1220b, and the third conductor enclosure 1220c may also be coupled to a solar panel and transfers AC power as discussed above to the solar panel. Any of the first conductor 1230a, the second conductor 1230b, and the third conductor 1230c may act as the hot, ground, and neutral when transferring AC power based which portion of the AC power is transferred from the output of the solar panel that the solar panel connector 1200 is coupled to that will be apparent to those skilled in the relevant art(s) without departing from the spirit and scope of the disclosure.

[00133] In another example, each of the first conductor enclosure 1210a, the second conductor enclosure 1210b, and the third conductor enclosure 1210c may be coupled to a

solar panel and receives DC power as discussed above from the solar panel. Upon receiving the DC power, the first conductor 1230a enclosed in the first conductor enclosure 1220a may act as the positive, the second conductor 1230b enclosed in the second conductor enclosure 1220b may act as the ground, and the third conductor 1230c enclosed in the third conductor enclosure 1220c may act as the negative. The first conductor enclosure 1220a, the second conductor enclosure 1220b, and the third conductor enclosure 1220c may also be coupled to a solar panel and transfers DC power as discussed above to the solar panel. Any of the first conductor 1230a, the second conductor 1230b, and the third conductor 1230c may act as the positive, negative, and ground when transferring DC power based which portion of the DC power is transferred from the output of the solar panel that the solar panel connector 1200 is coupled to that will be apparent to those skilled in the relevant art(s) without departing from the spirit and scope of the disclosure.

[00134] The center section 1240 may include a flexible material so that the center section 1240 may flex and/or bend. For example, the center section 1240 may flex and/or bend up to 90 degrees. The flexibility and/or bending characteristics of the center section 1240 may enable an installer that is assembling a daisy chain configuration of solar panels, such as the solar panel connector configuration 1100, additional flexibility when assembling the daisy chain configuration.

[00135] For example, the installer may not be limited to aligning the input of a first solar panel to an output of a second solar panel on the same plane to couple the two solar panels together with a connector. Rather, the flexibility of the center section 1240 enables the installer to align the input of the first solar panel to the output of the second solar panel at an angle to couple the two solar panels together with the solar panel connector 1200. The flexibility of the center section 1240 enables the solar panel connector 1200 to bend so that the installer does not have to get onto the same plane as the two solar panels to couple the two solar panels together. Rather, the installer has the flexibility to remain standing and couple the two solar panels together at an angle before laying each solar panel onto the same plane.

AN EXEMPLARY OPERATIONAL CONTROL FLOW OF THE SOLAR PANEL CONNECTOR CONFIGURATION

- [00136] FIG. 13 is a flowchart of exemplary operational steps of the solar panel connector configuration according to an exemplary embodiment of the present disclosure. The present disclosure is not limited to this operational description. Rather, it will be apparent to persons skilled in the relevant art(s) from the teachings herein that other operational control flows are within the scope and spirit of the present disclosure. The following discussion describes the steps in FIG. 13.
- [00137] At step 1310, the operational control flow couples a first conductor with a first end to an output of a first solar panel and a second end to an input of the second solar panel.
- [00138] At step 1320, the operational control flow couples a second conductor with a first end to the output of the first solar panel and a second end to the input of the second solar panel. Specifically, the operational control flow couples a first end of a second conductor, such as the second conductor 1230b enclosed by the second conductor enclosure 1210b, to the output of the first solar panel, such as the solar panel 100a, and a second end, such as the portion of the second conductor 1230b enclosed by the second conductor enclosure 1220b, to the input of the second solar panel, such as the solar panel 100b.
- [00139] At step 1330, the operational control flow couples a third conductor with a first end to the output of the first solar panel and a second end to the input of the second solar panel.
- [00140] At step 1340, the operational control flow transfers alternating current (AC) power to the second solar panel from the first solar panel when the first solar panel generates AC power. For example, the operational control flow transfers output AC power 195a to the solar panel 100b when the solar panel 100a generates AC power.
- [00141] At step 1350, the operational control flow transfers direct current (DC) power to the second solar panel when the first solar panel generates DC power.

CONCLUSION

[00142] It is to be appreciated that the Detailed Description section, and not the Abstract section, is intended to be used to interpret the claims. The Abstract section may set forth one or more, but not all exemplary embodiments, of the present disclosure, and thus, are not intended to limit the present disclosure and the appended claims in any way.

[00143] The present disclosure has been described above with the aid of functional building blocks illustrating the implementation of specified functions and relationships thereof. The boundaries of these functional building blocks have been arbitrarily defined herein for the convenience of the description. Alternate boundaries may be defined so long as the specified functions and relationships thereof are appropriately performed.

[00144] It will be apparent to those skilled in the relevant art(s) that various changes in form and detail can be made without departing from the spirit and scope of the present disclosure. Thus the present disclosure should not be limited by any of the above-described exemplary embodiments, but should be defined only in accordance with the following claims and their equivalents.

WHAT IS CLAIMED IS:

1. A solar panel, comprising:
 - a solar power collector configured to collect solar energy from a solar source and to convert the solar energy into direct current (DC) power;
 - a current amplifier configured to amplify the DC power;
 - a battery bank configured to store the amplified DC power;
 - an alternating current (AC) inlet receptacle configured to receive input AC power generated from an AC power source external to the solar panel;
 - a power signal sensor configured to detect when the input AC power is coupled to the AC inlet receptacle;
 - a controller configured to automatically generate parallel output AC power for the solar panel when the input AC power is coupled to the AC inlet receptacle, wherein the parallel output AC power is generated from the input AC power and the DC power stored in the battery bank that is converted to AC power so that the converted AC power is in parallel to the input AC power; and
 - an AC outlet receptacle configured to provide the parallel output AC power to systems external to the solar panel.
2. The solar panel of claim 1, wherein the parallel output AC power is synchronized with the input AC power.
3. The solar panel of claim 2, wherein a plurality of power characteristics associated with the parallel output AC power is substantially equivalent to a plurality of power characteristics associated with the input AC power.
4. The solar panel of claim 2, wherein the parallel output AC power includes a sinusoidal wave that is substantially equivalent to the sinusoidal wave included in the input AC power.

5. The solar panel of claim 1, wherein the controller is further configured to automatically transition the parallel output AC power generated by the solar panel to standalone output AC power when the power signal sensor no longer detects the input AC power coupled to the AC inlet receptacle.
6. The solar panel of claim 5, wherein the AC outlet receptacle is further configured to provide the standalone output AC power to the systems external to the solar panel when the power signal sensor no longer detects the input AC power coupled to the AC inlet receptacle, wherein the standalone output AC power is converted from the DC power stored in the battery bank of the solar panel.
7. The solar panel of claim 6, wherein the AC outlet receptacle is further configured to provide the standalone output AC power to systems external to the solar panel.
8. A solar panel, comprising:
 - a battery bank configured to store direct current (DC) power;
 - an alternating current (AC) inlet receptacle configured to receive input AC power generated from an AC power source external to the solar panel;
 - an AC outlet receptacle configured to provide output AC power to systems external to the solar panel;
 - a DC to AC converter configuration configured to:
 - generate parallel output AC power to the AC outlet receptacle when the solar panel is operating in a slave mode, wherein the parallel output AC power is output AC power generated from the input AC power and DC power stored in the battery bank that is converted to AC power that is in parallel with the input AC power, and
 - generate standalone output AC power to the AC outlet receptacle when the solar panel is operating in a master mode, wherein the standalone output AC power is generated from the AC power converted from the DC power stored in the battery bank.

9. The solar panel of claim 8, wherein the DC to AC converter configuration comprises:

a DC to AC converter configured to convert the DC power generated by the battery bank to the AC power when the battery bank provides DC power to the DC to AC converter;

a first relay coupled to the AC inlet receptacle and the AC outlet receptacle and configured to transition into an open state when the solar panel is operating in a master mode to prevent any remaining input AC power from reaching the AC output receptacle; and

a second relay coupled to the DC to AC converter and the AC outlet receptacle and configured to transition to a closed state when the solar panel is operating in the master mode so that the standalone AC power provided by the DC to AC converter passes through the second relay to the AC output receptacle.

10. The solar panel of claim 9, wherein:

the second relay is configured to transition to an open state when the solar panel is transitioning from the master mode to the slave mode so that the standalone AC power provided by the DC to AC converter is prevented from reaching the AC output receptacle during the transition from the master mode to the slave mode; and

the first relay is configured to transition to the closed state when the solar panel is transitioning from the master mode to the slave mode so that the input AC power passes through the first relay to the AC output receptacle.

11. The solar panel of claim 10, further comprising:

a controller configured to synchronize the input AC power coupled to the AC inlet receptacle to the AC power generated by the DC to AC converter before the AC power is provided to the AC outlet receptacle during the transition from the master mode to the slave mode.

12. The solar panel of claim 11, wherein the second relay is further configured to transition to the closed state after the controller has synchronized the input AC power to the converted AC power to generate the parallel AC output power to the AC outlet receptacle so that the solar panel is operating in the slave mode.

13. The solar panel of claim 12, wherein the second relay is further configured to remain in the open state when the controller fails to synchronize the input AC power to the converted AC power preventing the converted AC power from reaching the output AC receptacle to mix with the input AC power.

14. The solar panel of claim 9, wherein
the first relay is configured to transition into a closed state when the solar panel is operating in a bypass mode so that the input AC power passes through first relay to the AC output receptacle; and

the second relay is configured to transition into an open state when the solar panel is in the bypass mode to prevent any remaining converted AC power from reaching the output AC receptacle.

15. A solar panel configuration, comprising:

a plurality of solar panels configured to collect solar energy from a solar source and to convert the solar energy into direct current (DC) power;

a first solar panel included in the plurality of solar panels configured to:

automatically generate first standalone output AC power for the first solar panel when the first solar panel fails to detect first input AC power coupled to the first solar panel, wherein the first standalone output AC power is output AC power generated from the DC power of the first solar panel, and

act as a master solar panel when the first solar panel fails to detect the first input AC power coupled to the first solar panel, wherein the master solar panel automatically provides the first standalone output AC power to a slave solar panel included in the plurality of solar panels; and

a second solar panel included in the plurality of solar panels configured to:

automatically transition into generating second parallel output AC power, wherein the second parallel output AC power is second standalone output AC power generated by the second solar panel that is in parallel with the first standalone output AC power generated by the first solar panel, and

act as a slave solar panel when the second solar panel detects the first standalone output AC power provided by the first solar panel.

16. The solar panel configuration of claim 15, wherein the first standalone output AC power is synchronized with the second standalone output AC power.

17. The solar panel configuration of claim 16, wherein a plurality of power characteristics associated with the first standalone output AC power is substantially equivalent to a plurality of power characteristics associated with the input AC power.

18. The solar panel configuration of claim 16, wherein the first standalone output AC power includes a sinusoidal wave that is substantially equivalent to the sinusoidal wave included in the second standalone output AC power.

19. The solar panel configuration of claim 15, wherein the first solar panel is further configured to:

automatically transition to generating the first parallel output AC power, wherein the first parallel output power is the first standalone output AC power generated by the first solar panel that is in parallel with the second input AC power when the first solar panel detects the second input AC power coupled to the first solar panel; and

act as the slave solar panel when the first solar panel detects the second input AC power coupled to the first solar panel.

20. The solar panel configuration of claim 15, wherein the second solar panel is further configured to:

automatically generate the second standalone output AC power for the second solar panel when the second solar panel fails to detect the first input AC power coupled to the second solar panel; and

act as a master solar panel when the second solar panel fails to detect the first input AC power coupled to the second solar panel, wherein the master solar panel automatically provides the second standalone output AC power to the slave solar panel included in the plurality of solar panels.

21. A solar panel connector, comprising:

a first conductor with a first end coupled to an output of a first solar panel and a second end coupled to an input of the second solar panel,

a second conductor with a first end coupled to the output of the first solar panel and a second end coupled to the input of the second solar panel, and

a third conductor with a first end coupled to the output of the first solar panel and the second end coupled to the input of the second solar panel,

wherein the first conductor is configured to transfer alternating current (AC) power to the second solar panel when the first solar panel generates AC power and to transfer direct current (DC) power to the second solar panel when the first solar panel generates DC power.

22. The solar panel connector of claim 1, wherein:

the first conductor is further configured to act as a hot element of the AC power,

the second conductor is further configured to act as a ground element of the AC power, and

the third conductor is further configured to act as a neutral element of the AC power,

when the first solar panel generates AC power.

23. The solar panel connector of claim 1, wherein:
the first conductor is further configured to act as a positive element of the DC power,
the second conductor is further configured to act as the ground element of the DC power, and
the third conductor is further configured to act as a negative element of the DC power,
when the first solar panel generates DC power.
24. The solar panel connector of claim 1, wherein the first conductor, the second conductor, and the third conductor are further configured to automatically transfer AC power to the second solar panel when the first solar panel generates AC power.
25. The solar panel connector of claim 1, wherein the first conductor, the second conductor, and the third conductor are further configured to automatically transfer DC power to the second solar panel when the first solar panel generates DC power.
26. The solar panel connector of claim 1, wherein the first conductor, the second conductor, and the third conductor are further configured to transmit data from the first solar panel to the second solar panel.
27. The solar panel connector of claim 6, wherein the first conductor, the second conductor, and the third conductor are further configured to transmit data using power line modem (PLM) data transfer.
28. The solar panel connector of claim 1, further comprising:
a first conductor enclosure that encloses a first portion of the first conductor and is configured to mate with a first output of the first solar panel;
a second conductor enclosure that encloses a first portion of the second conductor and is configured to mate with a second output of the first solar panel; and
a third conductor enclosure that encloses a first portion of the third conductor and is configured to mate with a third output of the first solar panel.

29. The solar panel connector of claim 1, further comprising:
a first conductor enclosure that encloses a second portion of the first conductor and is configured to mate with a first input of the second solar panel;
a second conductor enclosure that encloses a second portion of the second conductor and is configured to mate with a second input of the second solar panel; and
a third conductor enclosure that encloses a second portion of the third conductor and is configured to mate with a third input of the second solar panel.
30. The solar panel connector of claim 1, further comprising:
an end cable coupled to an output of the second solar panel that is configured to transfer the AC power from the second solar panel to a second configuration to power the second configuration with the AC power when the first solar panel generates AC power.
31. The solar panel connector of claim 10, wherein the end cable is further configured to transfer the DC power from the second solar panel to a DC/AC inverter to convert the DC power to AC power when the first solar panel generates DC power.
32. The solar panel connector of claim 10, wherein the end cable comprises:
a first conductor enclosure that encloses a first portion of a first conductor and is configured to mate with a first output of the second solar panel;
a second conductor enclosure that encloses a first portion of a second conductor and is configured to mate with a second output of the second solar panel; and
a third conductor enclosure that encloses a first portion of the third conductor and is configured to mate with a third output of the second solar panel.
33. The solar panel connector of claim 12, wherein the end cable further comprises:
a first conductor enclosure that encloses a second portion of the first conductor and is configured to mate with a first input of the second configuration;
a second conductor enclosure that encloses a second portion of the second conductor and is configured to mate with a second input of the second configuration; and

a third conductor enclosure that encloses a second portion of the third conductor and is configured to mate with a third input of the second configuration.

34. The solar panel connector of claim 11, wherein the end cable further comprises:

a first conductor enclosure that encloses a second portion of the first conductor and is configured to mate with a first input of the DC/AC inverter;

a second conductor enclosure that encloses a second portion of the second conductor and is configured to mate with a second input of the DC/AC inverter; and

a third conductor enclosure that encloses a second portion of the third conductor and is configured to mate with a third input of the DC/AC inverter.

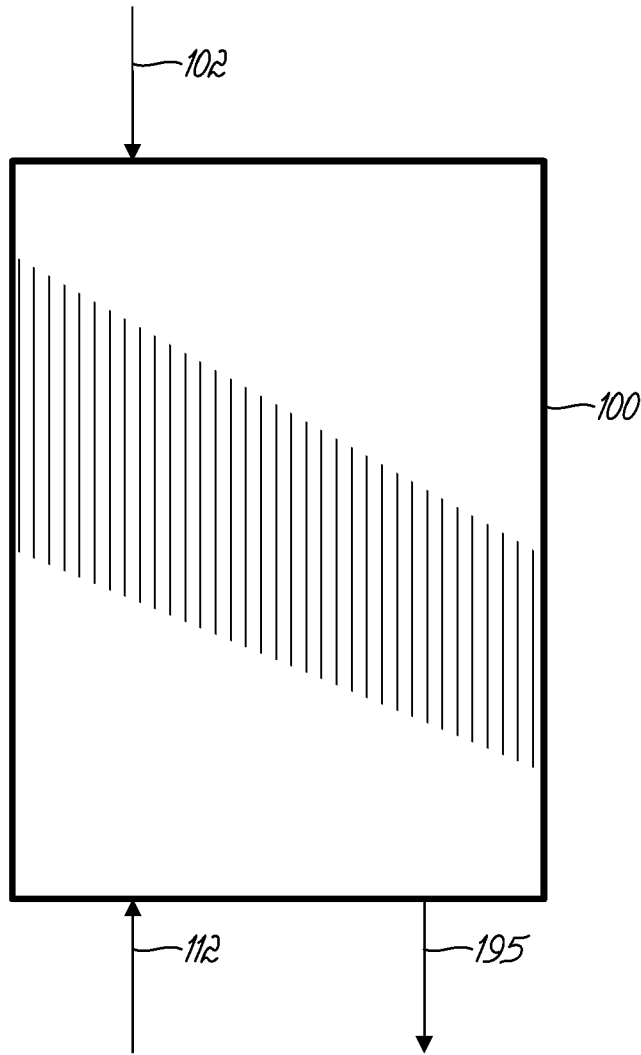

FIG. 1

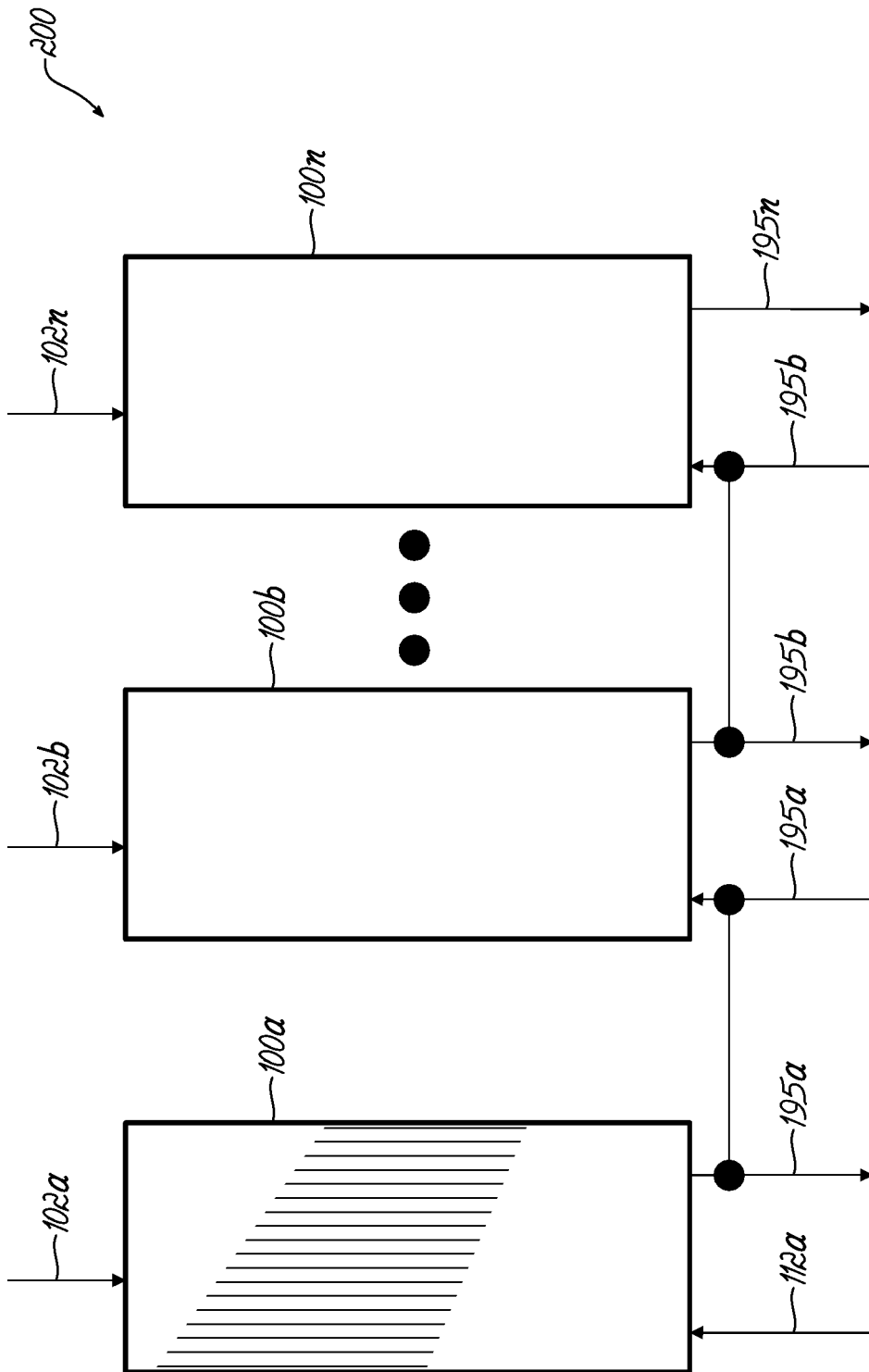

FIG. 2

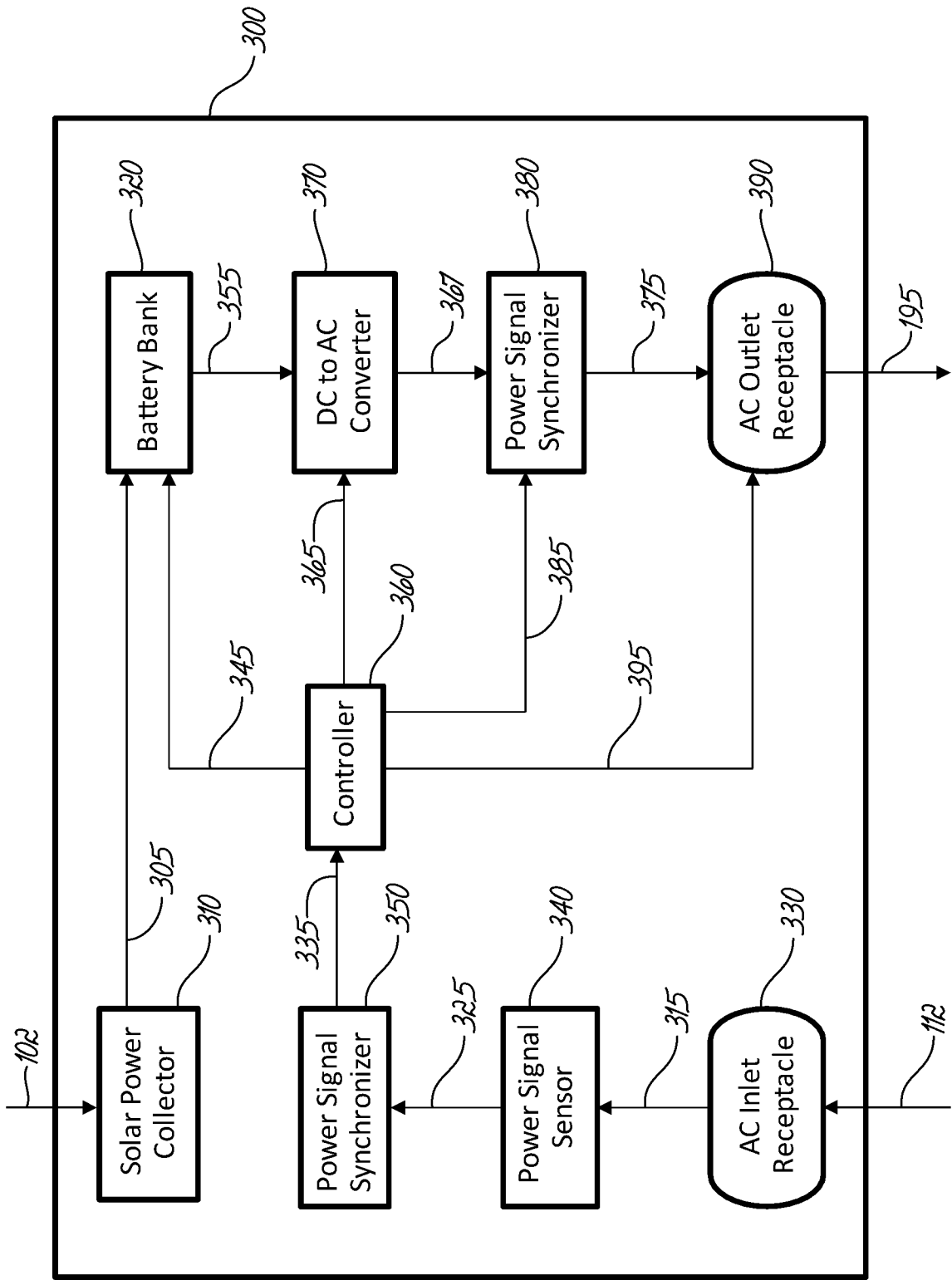

FIG. 3

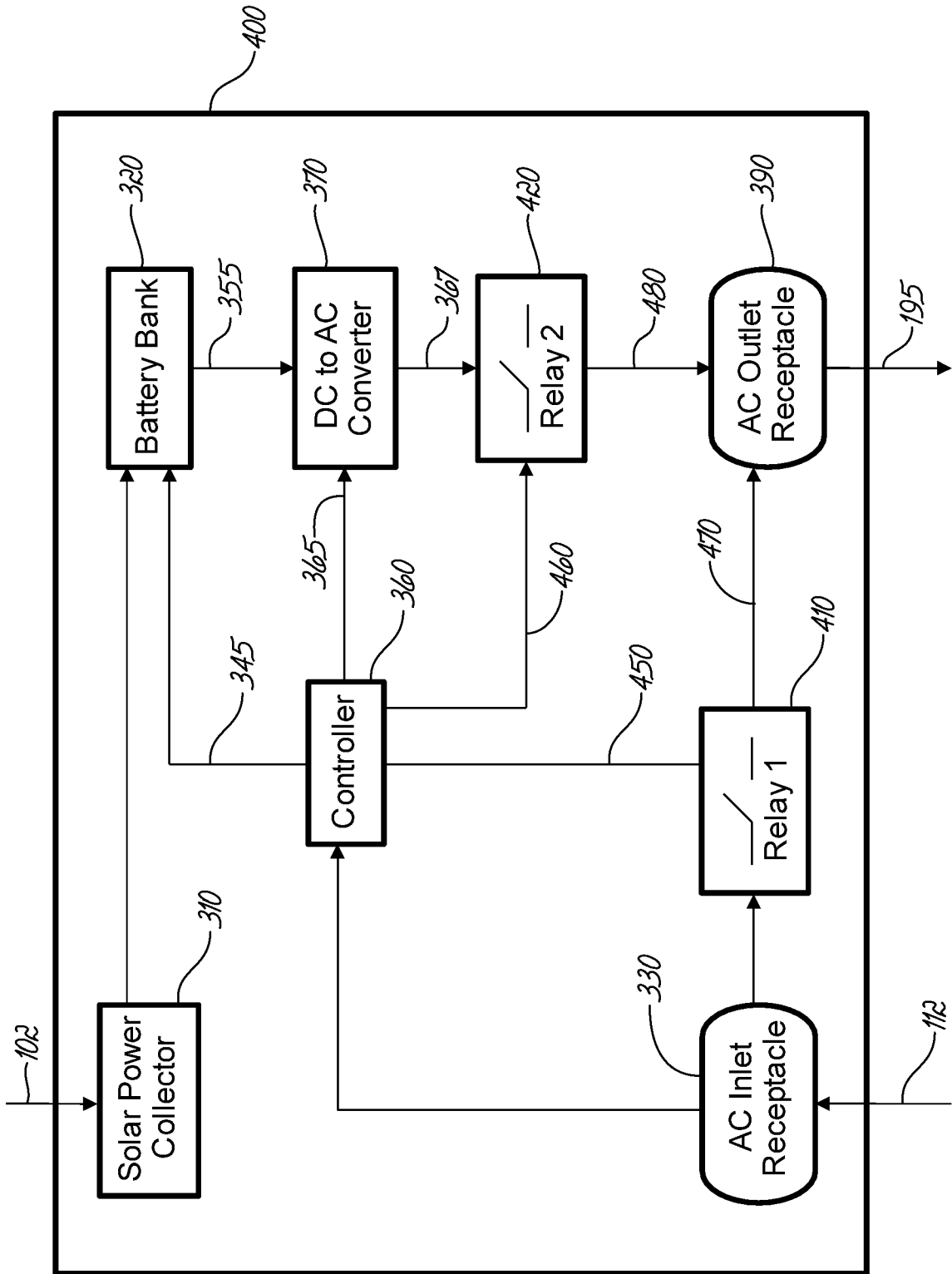

FIG. 4

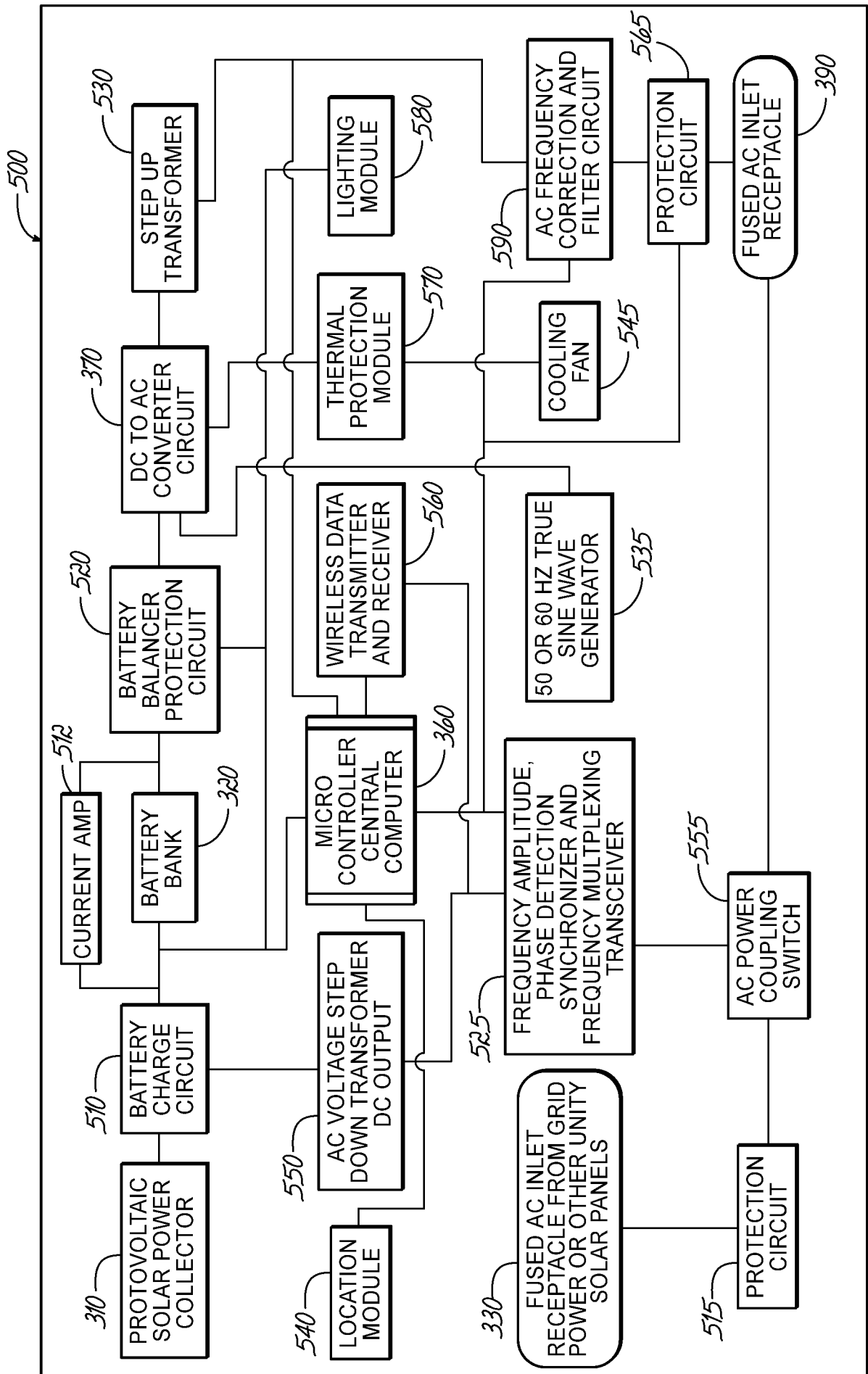

FIG. 5

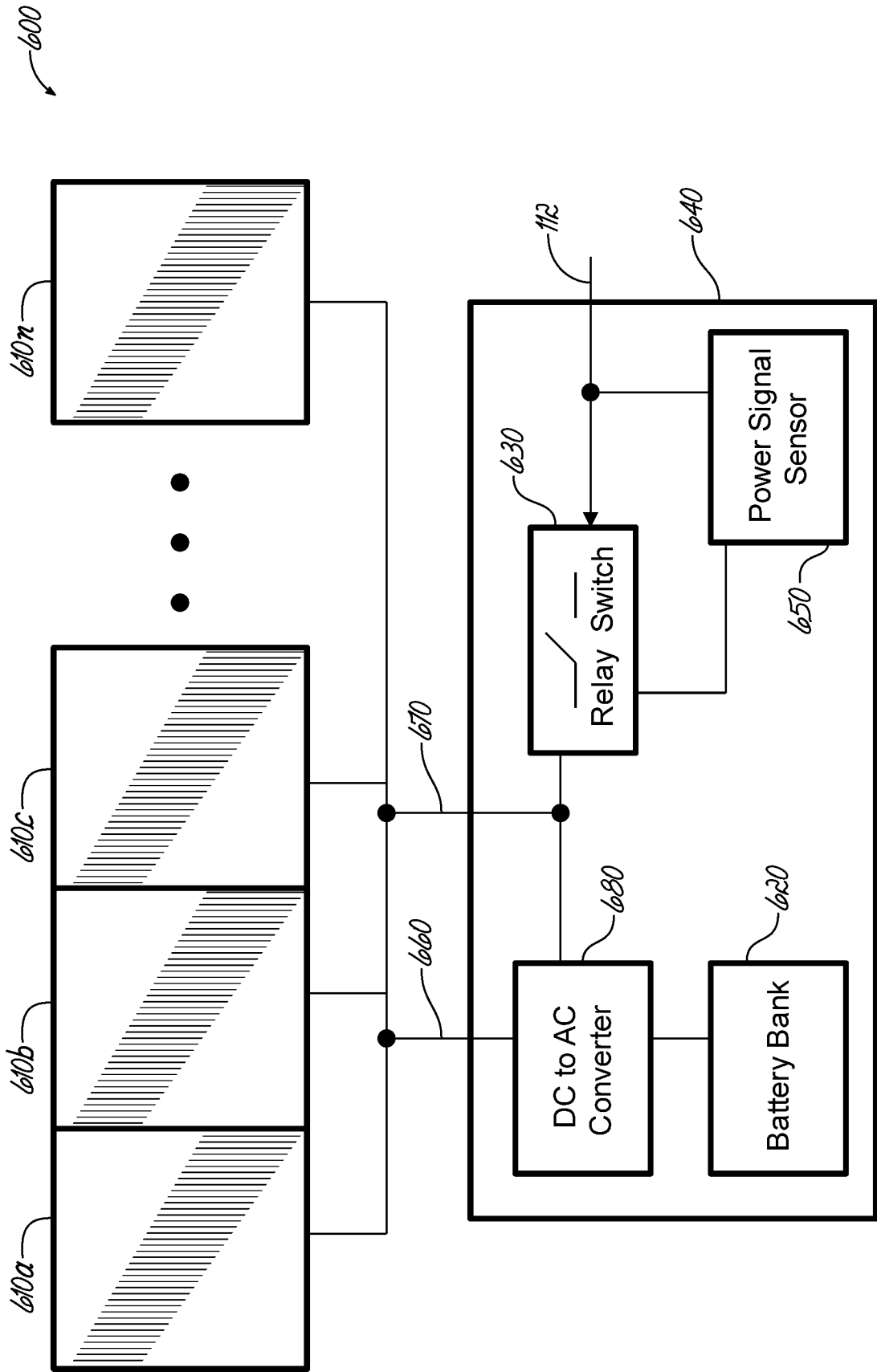

FIG. 6

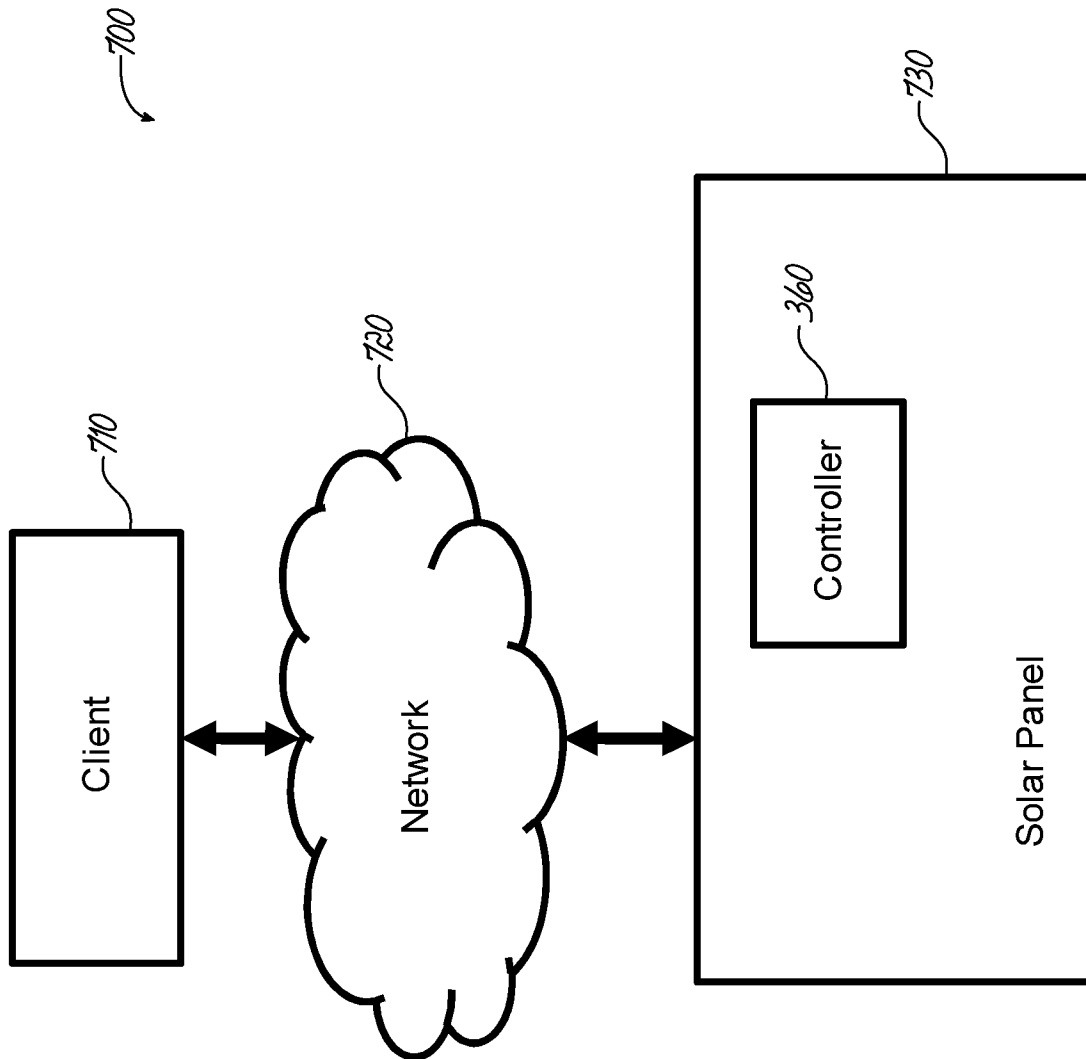
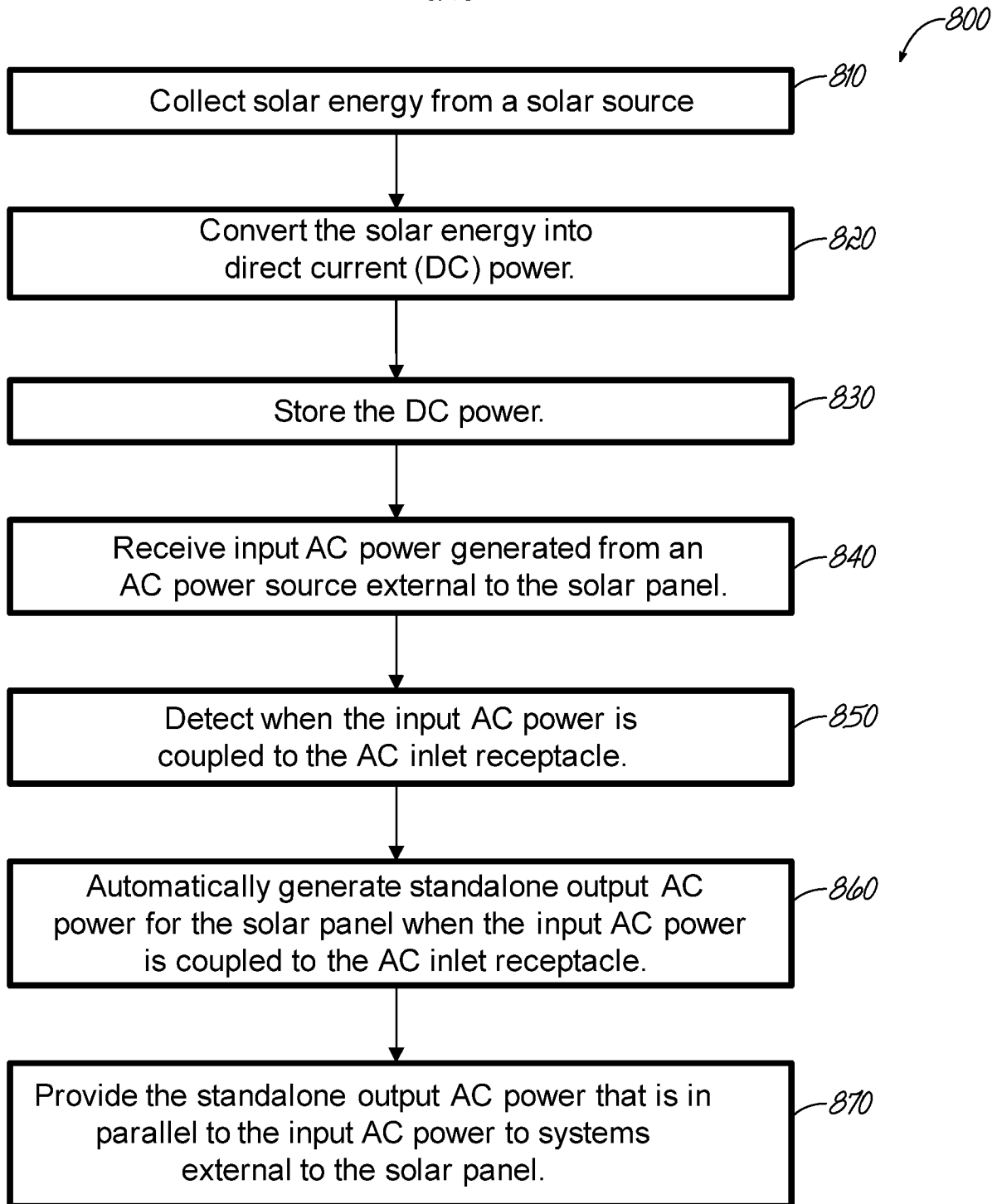

FIG. 7

8/13

**FIG. 8**

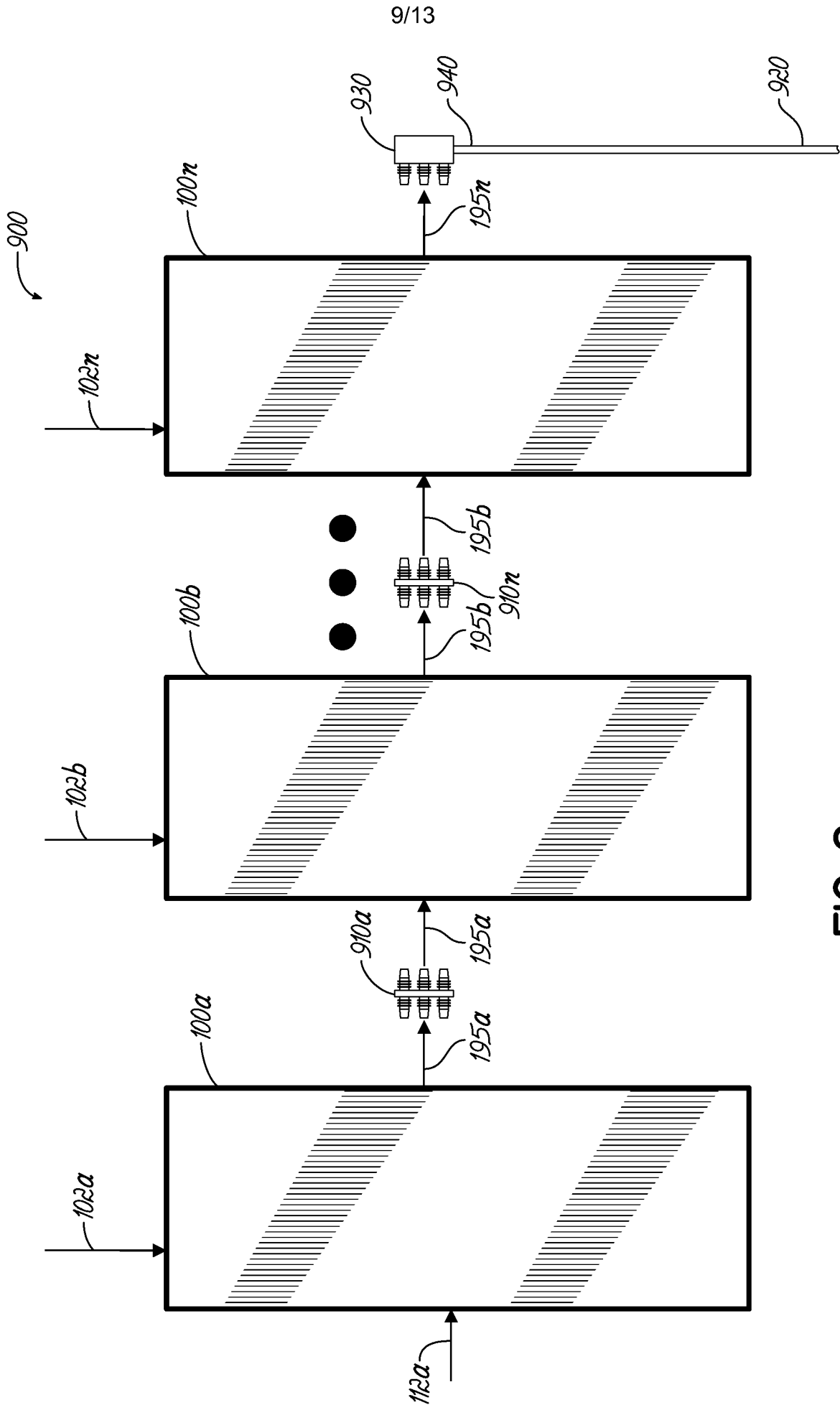

FIG. 9

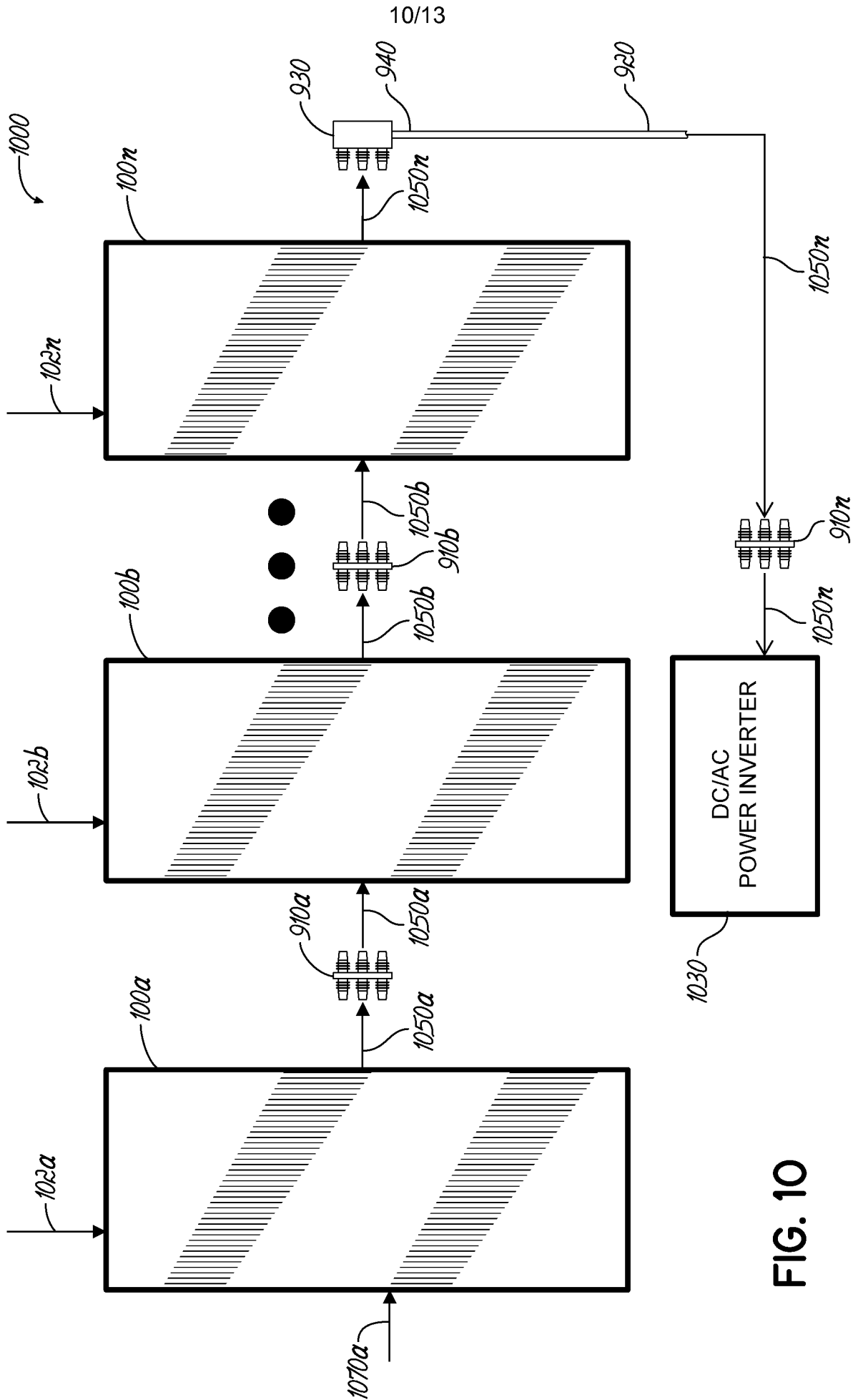

FIG. 10

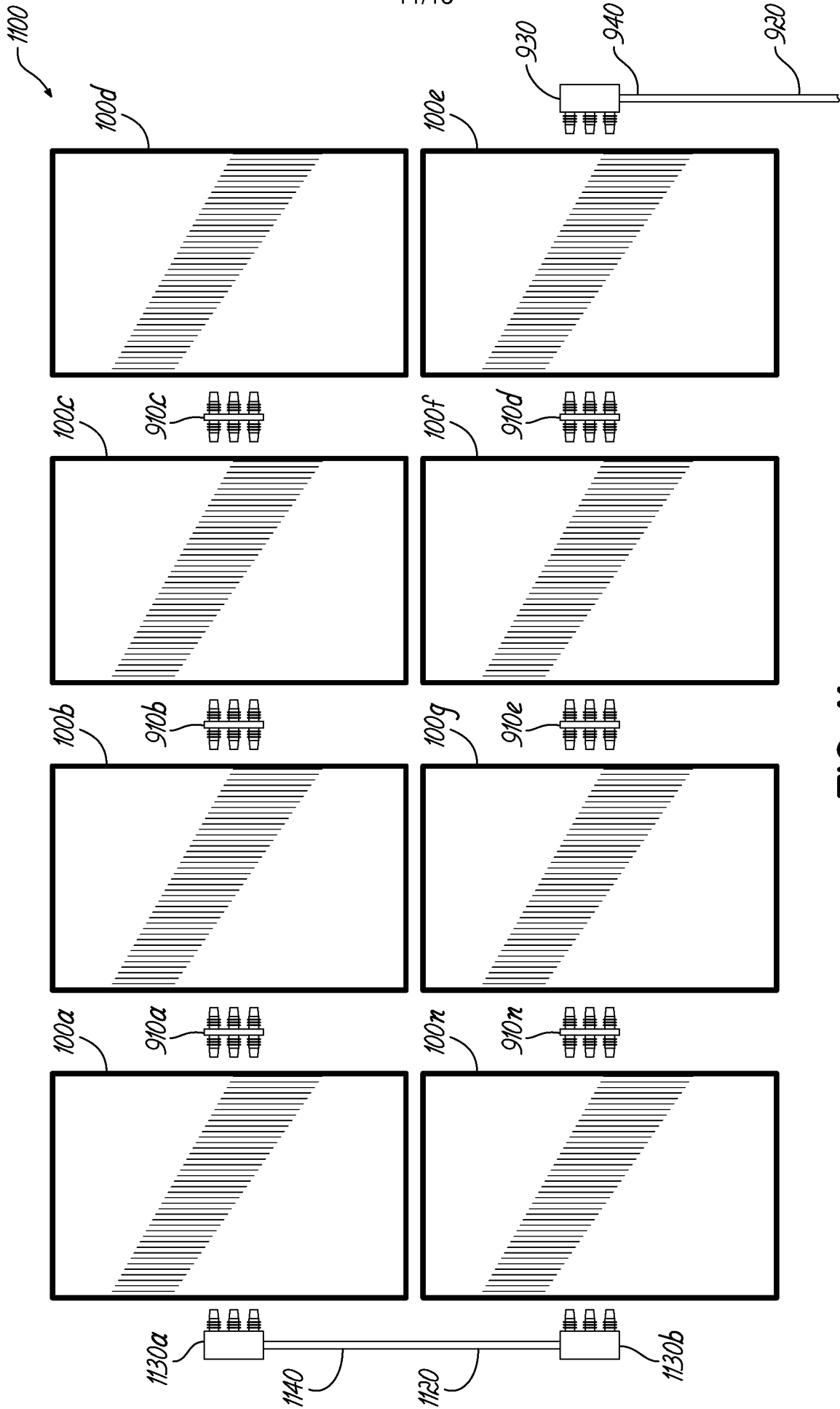

FIG. 11

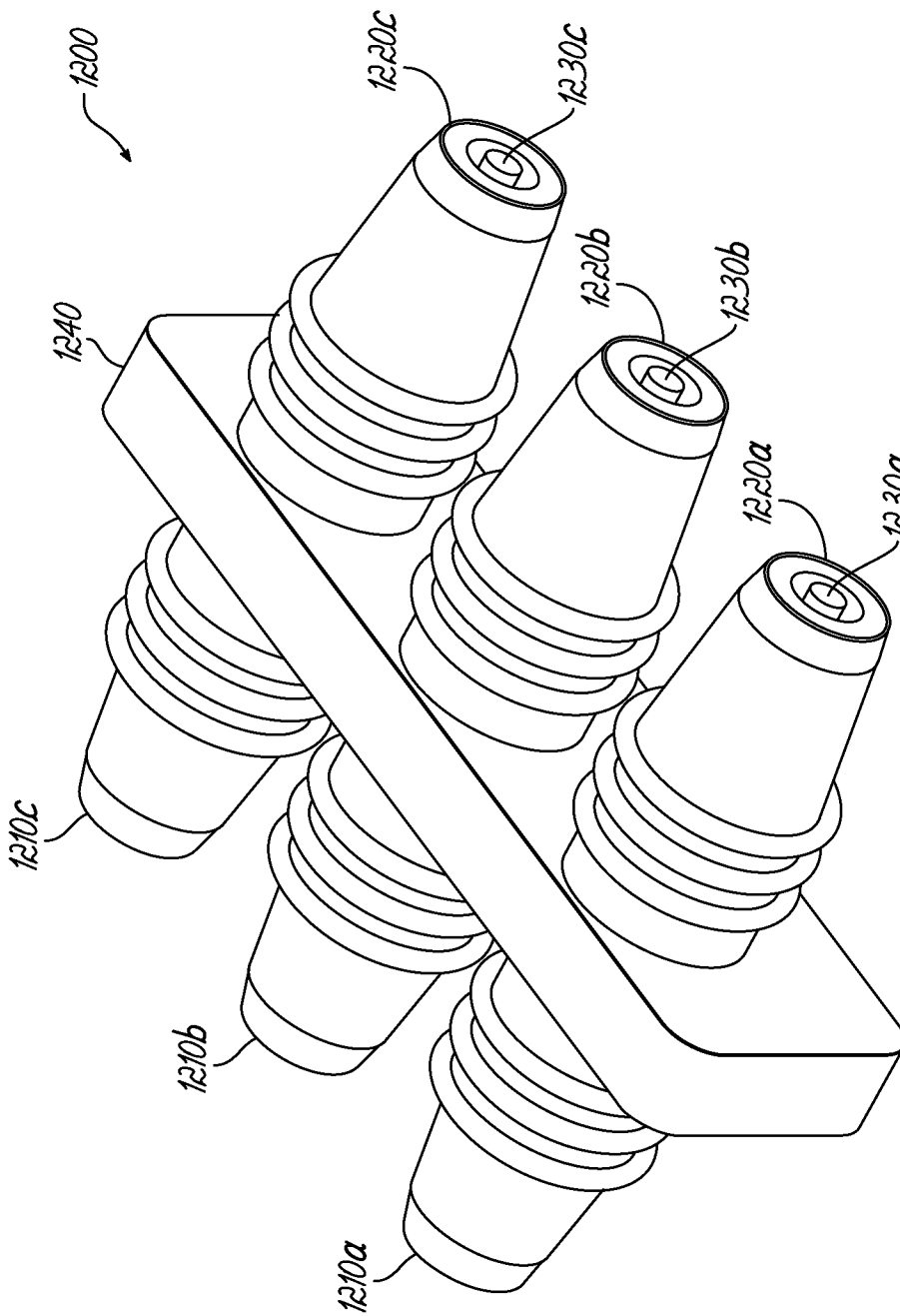
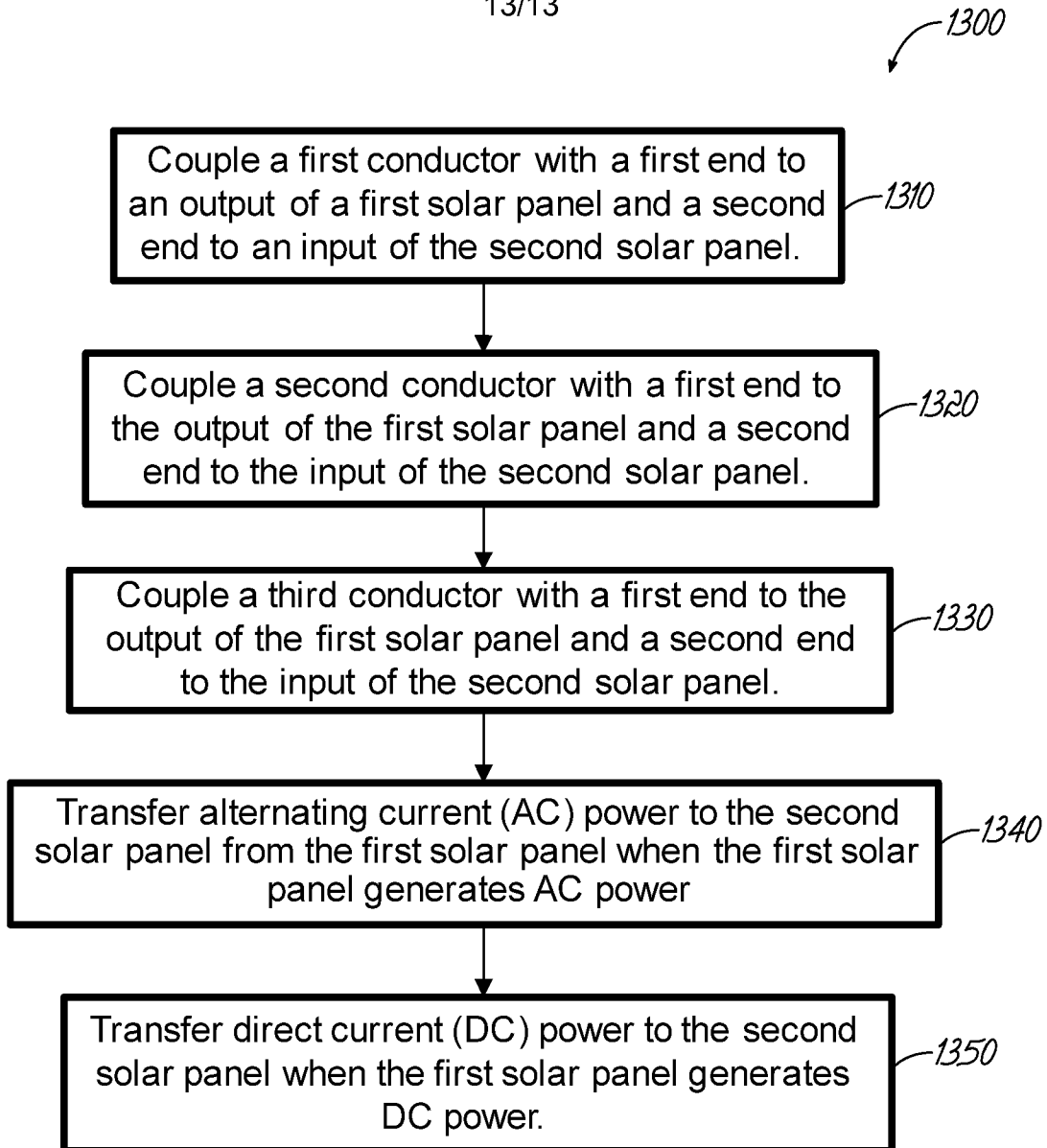

FIG. 12

13/13

**FIG. 13**