



- (51) **International Patent Classification:**
F24C 15/16 (2006.01)
- (21) **International Application Number:**
PCT/EP2015/065499
- (22) **International Filing Date:**
7 July 2015 (07.07.2015)
- (25) **Filing Language:** English
- (26) **Publication Language:** English
- (71) **Applicant:** ARCELIK ANONIM SIRKETI [TR/TR]; E5
Ankara Asfalti Uzeri, Tuzla, 34950 Istanbul (TR).
- (72) **Inventors:** DAVASLIGIL, Sena; E5 Ankara Asfalti
Uzeri, Tuzla, 34950 Istanbul (TR). DONMEZ, Ersin; E5
Ankara Asfalti Uzeri, Tuzla, 34950 Istanbul (TR). SEK-
MEN, Ramazan Ridvan; E5 Ankara Asfalti Uzeri Tuzla
Istanbul, 34950 Istanbul (TR).
- (81) **Designated States** (unless otherwise indicated, for every
kind of national protection available): AE, AG, AL, AM,
AO, AT, AU, AZ, BA, BB, BG, BH, BN, BR, BW, BY,

BZ, CA, CH, CL, CN, CO, CR, CU, CZ, DE, DK, DM,
DO, DZ, EC, EE, EG, ES, FI, GB, GD, GE, GH, GM, GT,
HN, HR, HU, ID, IL, IN, IR, IS, JP, KE, KG, KN, KP, KR,
KZ, LA, LC, LK, LR, LS, LU, LY, MA, MD, ME, MG,
MK, MN, MW, MX, MY, MZ, NA, NG, NI, NO, NZ, OM,
PA, PE, PG, PH, PL, PT, QA, RO, RS, RU, RW, SA, SC,
SD, SE, SG, SK, SL, SM, ST, SV, SY, TH, TJ, TM, TN,
TR, TT, TZ, UA, UG, US, UZ, VC, VN, ZA, ZM, ZW.

- (84) **Designated States** (unless otherwise indicated, for every
kind of regional protection available): ARIPO (BW, GH,
GM, KE, LR, LS, MW, MZ, NA, RW, SD, SL, ST, SZ,
TZ, UG, ZM, ZW), Eurasian (AM, AZ, BY, KG, KZ, RU,
TJ, TM), European (AL, AT, BE, BG, CH, CY, CZ, DE,
DK, EE, ES, FI, FR, GB, GR, HR, HU, IE, IS, IT, LT, LU,
LV, MC, MK, MT, NL, NO, PL, PT, RO, RS, SE, SI, SK,
SM, TR), OAPI (BF, BJ, CF, CG, CI, CM, GA, GN, GQ,
GW, KM, ML, MR, NE, SN, TD, TG).

Published:

- with international search report (Art. 21(3))

- (54) **Title:** AN OVEN

Figure 4

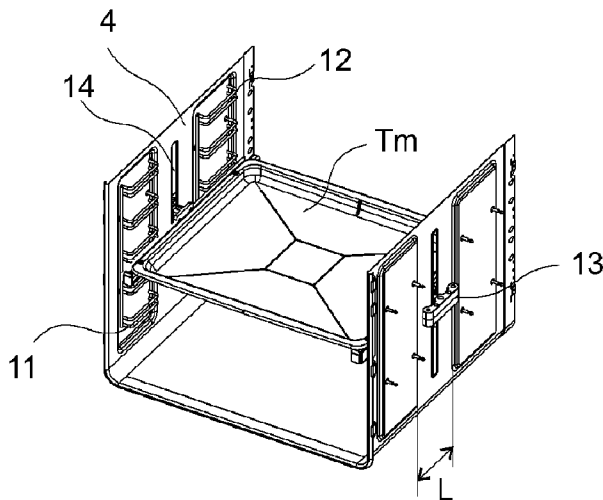

- (57) **Abstract:** The present invention relates to an oven (1) comprising: - a cooking chamber (2) wherein the trays containing the foodstuffs to be cooked are placed, - a casing (3) surrounding the cooking chamber (2), configured as a box with front side open and having two opposite side walls (4), - a movement mechanism (7) associated to the side walls (4) of the casing (3) and comprising a carrying means (8) whereon a movable tray (T_m) can be placed to be moved upwards/downwards inside the cooking chamber (2), and - a support unit (9) having carriers (10) for statically supporting at least one static tray (T_s) in the cooking chamber (2).

Description**AN OVEN**

- [0001] The present invention relates to an oven comprising a movement mechanism for vertically displacing a tray inside the cooking chamber. The oven according to the present invention further comprises a support unit for supporting one or more static trays.
- [0002] In the state of the art, ovens comprising support units mounted on the side walls of the cooking chamber and having carriers which provide the trays to be placed one over the other and spaced apart are generally used.
- [0003] In these embodiments, when the position of the tray inside the oven is required to be changed during a cooking process, the user has to perform this activity manually.
- [0004] In the state of the art, ovens are also known comprising a movement mechanism for supporting a tray and displacing it upwards/downwards inside the cooking chamber. Ovens comprising such movement mechanism are for instance described in the German Patent Application No. DE102004042827 and in the European Patent No. EP0792087.
- [0005] In these embodiments, the possibility to cook with more than one tray simultaneously disposed inside the oven is however not envisaged.
- [0006] It is moreover known from the international patent application WO 2013000901 an oven comprising a movement mechanism and a detachable support unit having more than one static support whereon trays can be placed and which is placed inside the oven by the user when desired. Therefore, the movable tray or the support unit for a plurality of static trays may be used selectively.
- [0007] The main drawback of the oven disclosed in WO 2013000901 resides on the fact that the support unit for the static trays needs to be removed from the oven and stored in a suitable place when the movable tray is in use, which is inconvenient.
- [0008] The aim of the present invention is the realization of an oven wherein a movable tray or support unit for holding a plurality of static trays can be indifferently used without requiring previous interventions by the user.
- [0009] In the oven realized in order to attain the aim of the present invention,

explicated in the first claim and the respective claims thereof, both a carrying means that can be moved by means of a movement mechanism and also a support unit for supporting one or more static trays are contemporary provided in the cooking chamber, so that the user can selectively decide to use a movable tray or one or more static trays.

- [0010] This is achieved by providing the oven according to the invention with a movement mechanism that occupies just a vertical portion of each of the side walls delimiting the cooking chamber, so that the support unit is mounted on the remaining portion of each of the side walls. In order to allow the free movement of the movable carrying means of the movement mechanism without having any interference between the carrying means and the fixed support unit, the movable carrying means is designed to be spaced apart from each of the side walls of a distance that is bigger than the extension of the support unit from each of the side walls. Therefore the movable carrying means, which extends parallel to the side walls for a length which approximately equal to the length of the cooking chamber, is free to slide in front of the support unit, spaced apart from it.
- [0011] In an embodiment, the movable tray has a width lower than the width of the static trays.
- [0012] According to an embodiment, the vertical portion of each of the side walls occupied by the movement mechanism is substantially centrally positioned on the side walls, equidistant from the rear wall and the frontal aperture of the casing.
- [0013] In a further embodiment the support unit comprises a frontal rack and a rear rack mounted on each of the side walls at the opposite sides of the vertical portion occupied by the movement mechanism.
- [0014] In an embodiment, the movement mechanism is mounted between the casing and an outer wall of the oven and comprises sliding lifting elements supporting the carrying means inside the cooking chamber and displacing them vertically in the cooking chamber.
- [0015] In a further embodiment, each of the side wall comprises a vertical slot through which one of the lifting elements extends.
- [0016] In an embodiment which allows the user to contemporary use both the

movable tray and one or more static trays, the oven further comprises a control unit that controls the movement of the carrying means in accordance with the cooking program selected by the user and with inputs provided by the user concerning the presence of static trays in the cooking chamber.

- [0017] In another embodiment, the oven comprises at least one sensor for detecting the presence of a static tray on the support unit and a control unit connected to the sensor, for receiving inputs from it related to the presence of a static tray and related to its position, and programmed to adjust the movements of the carrying means depending on these inputs.
- [0018] By means of the present invention, the oven is provided to perform safe cooking by using the movable carrying means or the support unit or even both of them contemporary, as preferred by the user.
- [0019] The oven realized in order to attain the aim of the present invention is illustrated in the attached figures, where:
- [0020] Figure 1 – is a partial perspective view of an oven according to the invention.
- [0021] Figure 2 – is a perspective view of a movement mechanism of the oven of Fig. 1, with a movable tray supported by it.
- [0022] Figure 3 – is a perspective view of a support unit of the oven of Fig. 1.
- [0023] Figure 4 – is a partial perspective view of the casing, the movement mechanism, the movable tray and the support unit of an oven according to the invention.
- [0024] Figure 5 – is the partial perspective view of Figure 4 with a static tray positioned on the support unit.
- [0025] Figure 6 – is a frontal view of the casing, the movement mechanism, the movable tray, the support unit and a static tray positioned on the support unit of an oven according to the invention.
- [0026] The elements illustrated in the figures are numbered as follows:
1. Oven
 2. Cooking chamber
 3. Casing
 4. Side wall

5. Rear wall
6. Frontal aperture
7. Movement mechanism
8. Carrying means
9. Support unit
10. Carriers
11. Frontal rack
12. Rear rack
13. Sliding lifting elements
14. Vertical slot

- [0027] The oven 1 comprises a cooking chamber 2 wherein the trays containing the foodstuffs to be cooked are placed and a casing 3 surrounding the cooking chamber 2, configured as a box with front side open and having two opposite side walls 4, a rear wall 5 and a frontal aperture 6.
- [0028] The oven 1 further comprises a movement mechanism 7, associated to the side walls 4 of the casing 3 and comprising carrying means 8 whereon a movable tray T_m can be placed to be moved upwards/downwards inside the cooking chamber 2, and a support unit 9 having carriers 10 for statically supporting at least one static tray T_s in the cooking chamber 2. More in detail the support unit 9 comprises a plurality of carriers 10 aimed to support as much static trays T_s placed one over the other and spaced apart.
- [0029] According to the present invention the movement mechanism 7 occupies a first vertical portion of each of the side walls 4 and the support unit 9 occupies a second different vertical portion of each of the side walls 4. More in detail, the support unit 9 is mounted in the cooking chamber 2 and, according to an embodiment, it is fixed to the side walls 4. The movable carrying means 8 is spaced apart from each of the side walls 4 of a distance bigger than the extension of the support unit 9 from each of the side walls 4. This allows the carrying means 8 to be freely displaced vertically without interfering with the support unit 9.
- [0030] Therefore, the support unit 9 for supporting static trays T_s and the movement mechanism 7 for supporting and displacing a movable tray T_m

are both constantly available in the oven 1 according to the invention, so that a user can selectively use static trays T_s or the movable tray T_m without needing to perform any previous intervention.

- [0031] According to an embodiment, the movable tray T_m has a width W_m lower than the width W_s of the static trays T_s . Considering the trays positioned in the cooking chamber 2 of the oven 1, the width is the dimension of the trays along a direction perpendicular to the side walls 4, as illustrated in Figure 6. This allows the movable tray T_m not to interfere with the carriers 10 of the support unit 9 aimed to hold the static trays T_s .
- [0032] In an embodiment illustrated in the attached figures, the first vertical portion of each of the side walls 4 occupied by the movement mechanism 7 is substantially equidistant from the rear wall 5 and the frontal aperture 6. Therefore the movement mechanism 7 is associated substantially to a central portion of the side walls 4. This allows the movement mechanism 7 to securely hold the movable tray T_m at intermediate positions of its side edges.
- [0033] In a further embodiment, the support unit 9 comprises a frontal rack 11 and a rear rack 12 mounted on each of the side walls 4 at the opposite sides of the first central vertical portion occupied by the movement mechanism 7, as illustrated in Figures 3 and 4 attached. Each of the racks, in a preferred embodiment, is advantageously defined by a group of carriers 10 placed one over the other and spaced apart.
- [0034] According to an embodiment, the oven 1 further comprises an outer wall (not illustrated) surrounding the casing 3 and the movement mechanism 7 is mounted between the casing 3 and the outer wall and comprises sliding lifting elements 13 supporting the carrying means 8 inside the cooking chamber 2.
- [0035] According to a further embodiment, each of the side walls 4 comprises a vertical slot 14 through which one of the lifting elements 13 extends.
- [0036] More in detail, according to an embodiment, the movement mechanism 7 comprises two columns, each associated to a respective side wall 4 of the casing 3, in particular placed between the casing 3 and the outer wall, and substantially aligned between them. According to this embodiment, each

column bears a motor M and transmission means for transmitting the motion of the motor M to one respective of the lifting elements 13, which is mounted on guides provided on the column, in order to displace it along a vertical path. The two counterposed lifting elements 13 carry the carrying means 8, so as to displace it vertically when they are moved by means of the respective motors M.

[0037] The first vertical portion of the side walls 4 occupied by the movement mechanism 7 in this embodiment is substantially a portion extending at the vertical slot 14 and at the sides of the vertical slot 14 for a length L embracing the extension of the lifting elements 13 and allowing a sufficient clearance for its easy displacement, as clearly visible in Figures 5 and 6.

[0038] Therefore the oven 1 according to the present invention allows the user to selectively use a movable tray T_m or one or more static trays T_s depending on the specific cooking needs. The user can hence place the foodstuff to be cooked in the desired tray or trays and select consequently the desired cooking program.

[0039] In case the user selects to use the movable tray T_m , the movement mechanism 7 will be actuated to raise and/or lower the carrying means 8 that supports the tray T_m in the different stages of the cooking process, according to the cooking program, i.e. according to the data stored in the memory of a control unit of the oven 1 and associated to the selected cooking program.

[0040] According to further embodiments of the oven 1, the user could even select to use the oven 1 with both a movable tray T_m and one or more static trays T_s positioned on the support unit 9, preferably positioned in this case on one of the carriers 10 closest to the top or bottom wall of the casing 3.

[0041] In particular, to this aim, in one embodiment the control unit of the oven 1 controls the movement of the carrying means 8 in accordance with the cooking program selected by the user and in accordance with further inputs provided by the user concerning the presence of static trays T_s in the cooking chamber 2 and their exact position in it.

[0042] This allows the user for instance to place a static tray T_s at the bottom of

the cooking chamber 2, while using contemporary the movable tray T_m which, accordingly, will be displaced by the movement mechanism 7, controlled by the control unit, along a vertical path extending only on the upper part of the cooking chamber 2.

[0043] According to a further embodiment, which is alternative or additional to the embodiment above described, the oven 1 further comprises at least one sensor (not illustrated) for detecting the presence of a static tray T_s on the support unit 9. The control unit, connected to the sensors, upon receiving inputs from the sensor or the sensors related to the presence of a static tray T_s and its exact position on the support unit 9, is programmed to adjust the movements of the carrying means 8 depending on these inputs.

[0044] By means of the present invention, the oven 1 allows the user to comfortably use either the movable carrying means 8 or the support unit 9, or even both of them contemporary, in a safe manner and without any previous intervention being required.

Claims

1. An oven (1) comprising:
 - a cooking chamber (2) wherein the trays containing the foodstuffs to be cooked are placed,
 - a casing (3) surrounding the cooking chamber (2), configured as a box with front side open and having two opposite side walls (4),
 - a movement mechanism (7) associated to the side walls (4) of the casing (3) and comprising carrying means (8) whereon a movable tray (T_m) can be placed to be moved upwards/downwards inside the cooking chamber (2),
 - a support unit (9) having carriers (10) for statically supporting at least one static tray (T_s) in the cooking chamber (2),**characterized in that** the movement mechanism (7) occupies a first vertical portion of each of the side walls (4) and the support unit (9) occupies a second different vertical portion of each of the side walls (4), the movable carrying means (8) being spaced apart from each of the side walls (4) of a distance bigger than the extension of the support unit (9) from each of the side walls (4).
2. An oven (1) as in Claim 1, **characterized in that** the movable tray (T_m) has a width (W_m) lower than the width (W_s) of the static trays (T_s).
3. An oven (1) as in Claim 1 or 2, **characterized in that** the casing (3) has a rear wall (5) and a frontal aperture (6) and the first vertical portion of each of the side walls (4) occupied by the movement mechanism (7) is substantially equidistant from the rear wall (5) and the frontal aperture (6).
4. An oven (1) as in Claim 3, **characterized in that** the support unit (9) comprises a frontal rack (11) and a rear rack (12) mounted on each of the side walls (4) at the opposite sides of the first vertical portion occupied by the movement mechanism (7).
5. An oven (1) as in any of the previous claims, **characterized in that** it further comprises an outer wall surrounding the casing (3) and the movement mechanism (7) is mounted between the casing (3) and the outer wall and comprises sliding lifting elements (13) supporting the carrying means (8) inside the cooking chamber (2).
6. An oven (1) as in Claim 5, **characterized in that** each of the side wall (4) comprises a vertical slot (14) through which one of the lifting elements (13)

extends.

7. An oven (1) as in any of the previous claims, **characterized in that** it further comprises a control unit that controls the movement of the carrying means (8) in accordance with the cooking program selected by the user and with inputs provided by the user concerning the presence of static trays (T_S) in the cooking chamber (2).
8. An oven (1) as in any of the previous claims, **characterized in that** it further comprises at least one sensor for detecting the presence of a static tray (T_S) on the support unit (9) and a control unit connected to the sensor, for receiving inputs from it related to the presence of a static tray (T_S), and programmed to adjust the movements of the carrying means (8) depending on said inputs.

Figure 1

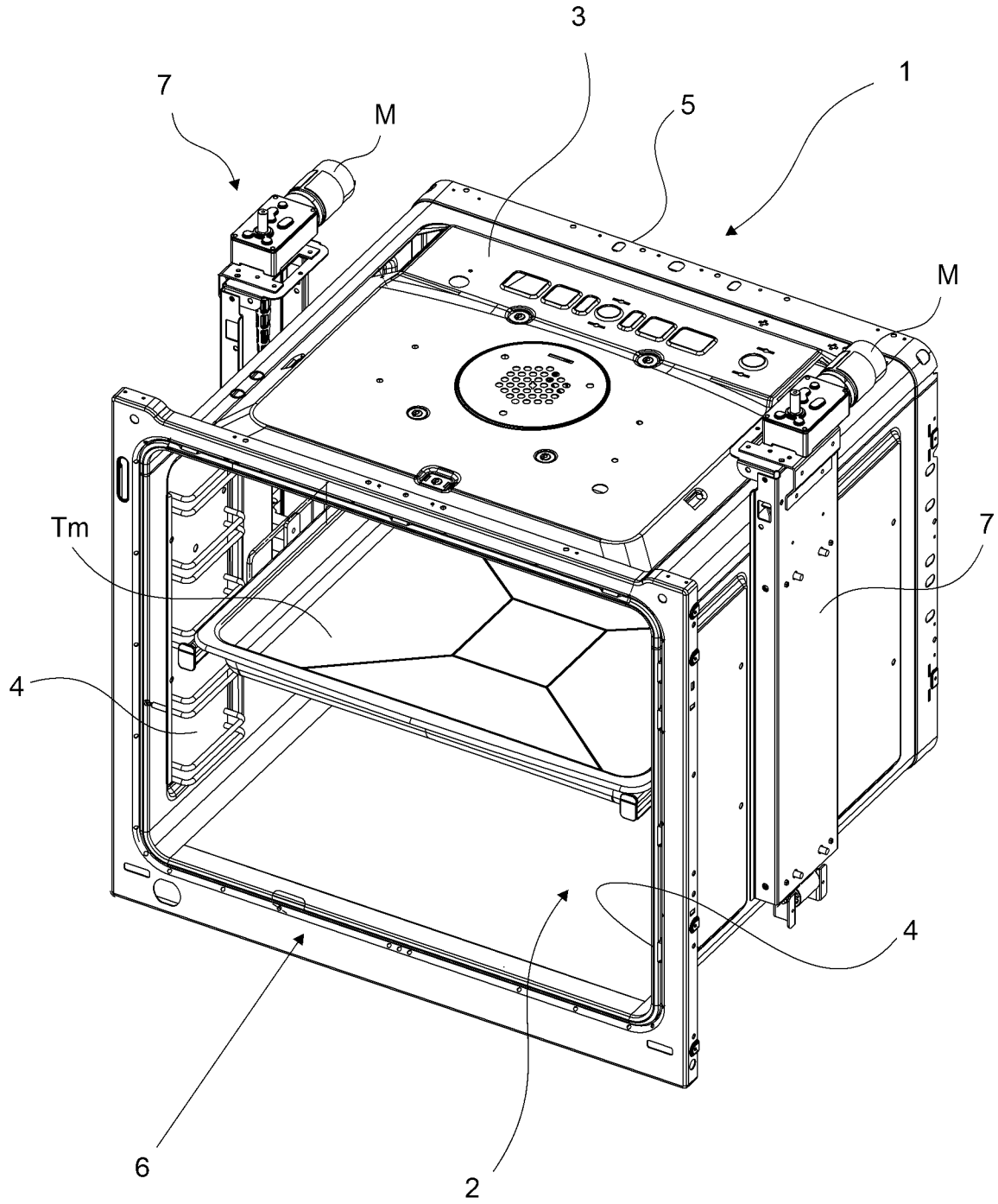

Figure 2

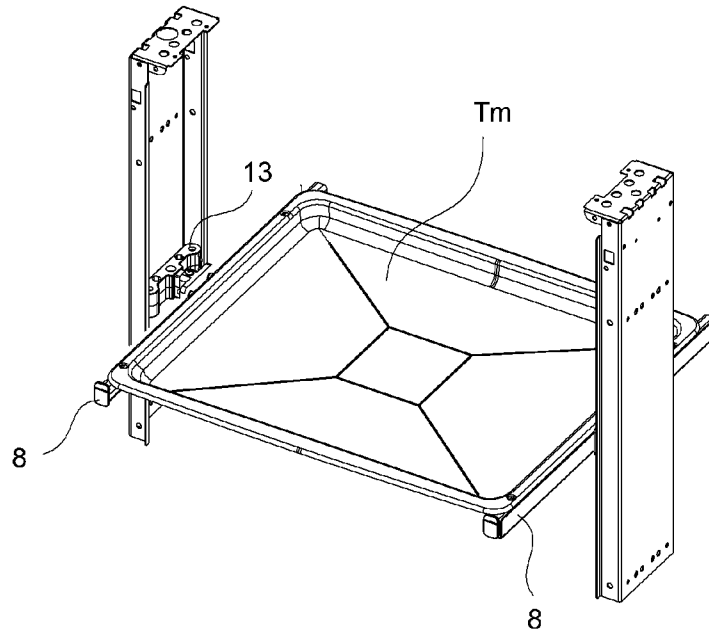

Figure 3

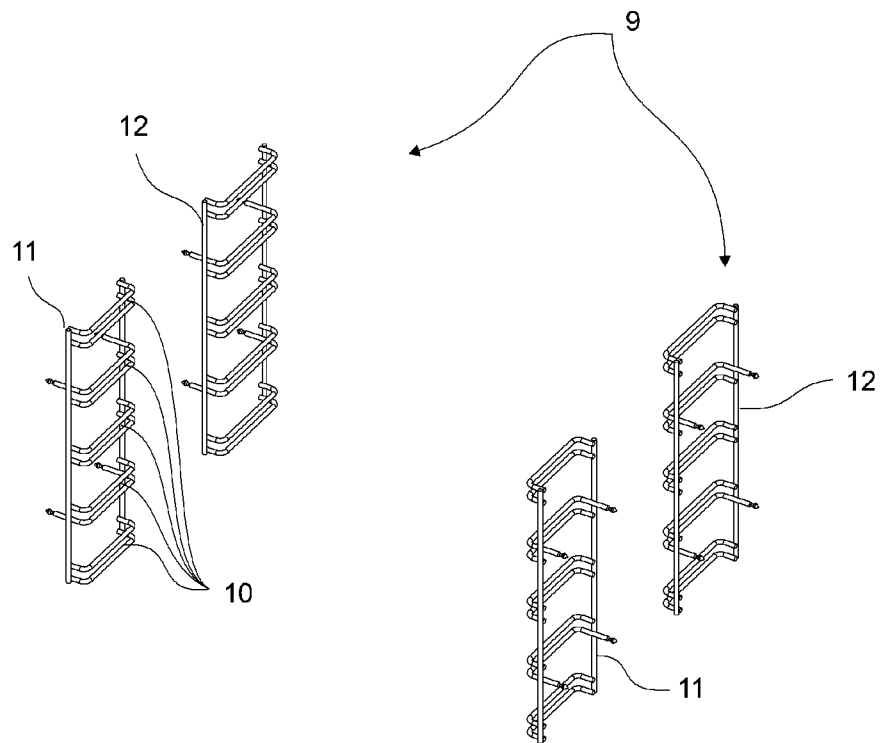

Figure 4

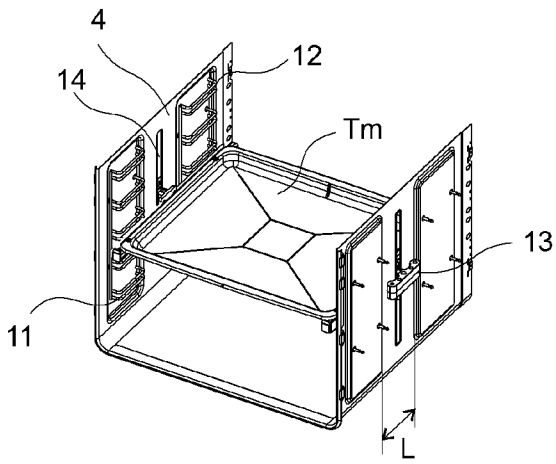

Figure 5

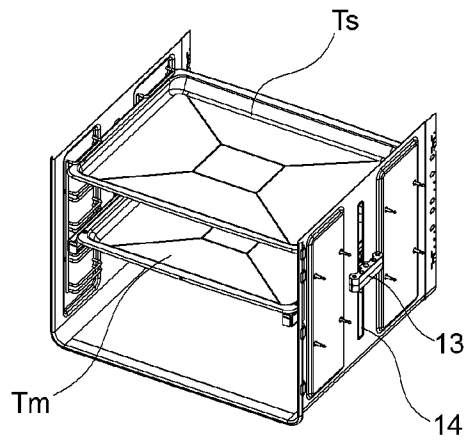
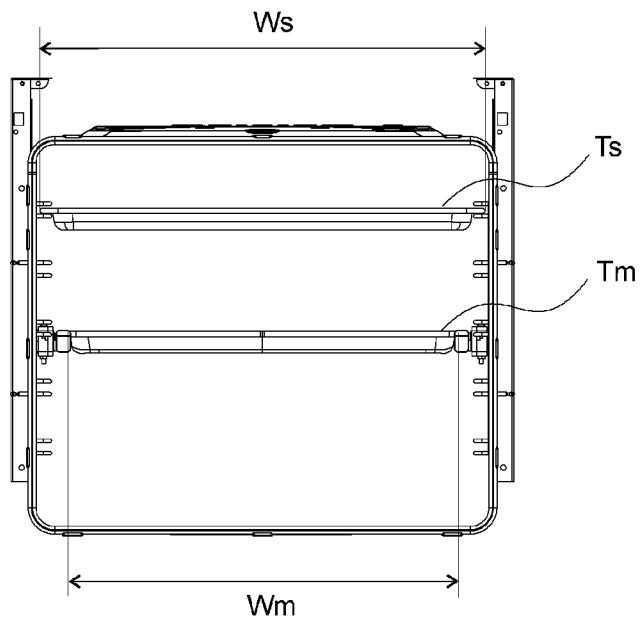

Figure 6



INTERNATIONAL SEARCH REPORT

International application No
PCT/EP2015/065499

A. CLASSIFICATION OF SUBJECT MATTER
INV. F24C15/16
ADD.
According to International Patent Classification (IPC) or to both national classification and IPC

B. FIELDS SEARCHED
Minimum documentation searched (classification system followed by classification symbols)
F24C

Documentation searched other than minimum documentation to the extent that such documents are included in the fields searched

Electronic data base consulted during the international search (name of data base and, where practicable, search terms used)
EPO-Internal, WPI Data

C. DOCUMENTS CONSIDERED TO BE RELEVANT

Category*	Citation of document, with indication, where appropriate, of the relevant passages	Relevant to claim No.
Y	WO 2013/000901 A1 (ARCELIK AS [TR]; CENGIZ OSMAN [TR]; GOCER MEHMET BARIS [TR]; KOK ERDEM) 3 January 2013 (2013-01-03) cited in the application the whole document	1-8
Y	WO 2013/116606 A2 (EURO PRO OPERATING LLC [US]) 8 August 2013 (2013-08-08) the whole document	1-8
X	US 2 834 334 A (WILLIAM BILL) 13 May 1958 (1958-05-13)	1
Y	the whole document	2
A	JP S63 150220 U (JPS63150220U) 3 October 1988 (1988-10-03) the whole document	1-8

Further documents are listed in the continuation of Box C.

See patent family annex.

* Special categories of cited documents :

- "A" document defining the general state of the art which is not considered to be of particular relevance
- "E" earlier application or patent but published on or after the international filing date
- "L" document which may throw doubts on priority claim(s) or which is cited to establish the publication date of another citation or other special reason (as specified)
- "O" document referring to an oral disclosure, use, exhibition or other means
- "P" document published prior to the international filing date but later than the priority date claimed

- "T" later document published after the international filing date or priority date and not in conflict with the application but cited to understand the principle or theory underlying the invention
- "X" document of particular relevance; the claimed invention cannot be considered novel or cannot be considered to involve an inventive step when the document is taken alone
- "Y" document of particular relevance; the claimed invention cannot be considered to involve an inventive step when the document is combined with one or more other such documents, such combination being obvious to a person skilled in the art
- "&" document member of the same patent family

Date of the actual completion of the international search 28 January 2016	Date of mailing of the international search report 08/02/2016
---	---

Name and mailing address of the ISA/ European Patent Office, P.B. 5818 Patentlaan 2 NL - 2280 HV Rijswijk Tel. (+31-70) 340-2040, Fax: (+31-70) 340-3016	Authorized officer Makúch, Milan
--	--

INTERNATIONAL SEARCH REPORT

Information on patent family members

International application No PCT/EP2015/065499

Patent document cited in search report		Publication date		Patent family member(s)	Publication date
WO 2013000901	A1	03-01-2013	CN	103620310 A	05-03-2014
			EP	2724083 A1	30-04-2014
			TR	201106339 A1	21-01-2013
			WO	2013000901 A1	03-01-2013

WO 2013116606	A2	08-08-2013	US	2015173551 A1	25-06-2015
			WO	2013116606 A2	08-08-2013

US 2834334	A	13-05-1958	NONE		

JP S63150220	U	03-10-1988	NONE		
