

(19) World Intellectual Property Organization  
International Bureau



(43) International Publication Date  
21 June 2007 (21.06.2007)

PCT

(10) International Publication Number  
**WO 2007/070802 A2**

(51) International Patent Classification: Not classified

(21) International Application Number:  
PCT/US2006/061937

(22) International Filing Date:  
12 December 2006 (12.12.2006)

(25) Filing Language: English

(26) Publication Language: English

(30) Priority Data:  
60/750,239 13 December 2005 (13.12.2005) US  
11/609,203 11 December 2006 (11.12.2006) US

(71) Applicant (for all designated States except US): **PETERSON PACIFIC CORPORATION** [US/US]; 29408 AIRPORT ROAD, Eugene, OR 97402 (US).

(72) Inventors; and

(75) Inventors/Applicants (for US only): **PETERSON, Arnold, N.** [US/US]; 29408 AIRPORT ROAD, Eugene, OR 97402 (US). **ALFORD, Peter, B.** [US/US]; 25507 HWY. 36, Chesire, OR 97419 (US).

(74) Agents: **GOODMAN, Christopher, D.** et al.; SCHWABE, WILLIAMSON & WYATT, P.C., PACWEST CENTER, SUITE 1900, 1211 SW FIFTH AVENUE, Portland, OR 97204 (US).

(81) Designated States (unless otherwise indicated, for every kind of national protection available): AE, AG, AL, AM, AT, AU, AZ, BA, BB, BG, BR, BW, BY, BZ, CA, CH, CN, CO, CR, CU, CZ, DE, DK, DM, DZ, EC, EE, EG, ES, FI, GB, GD, GE, GH, GM, GT, HN, HR, HU, ID, IL, IN, IS, JP, KE, KG, KM, KN, KP, KR, KZ, LA, LC, LK, LR, LS, LT, LU, LV, LY, MA, MD, MG, MK, MN, MW, MX, MY, MZ, NA, NG, NI, NO, NZ, OM, PG, PH, PL, PT, RO, RS, RU, SC, SD, SE, SG, SK, SL, SM, SV, SY, TJ, TM, TN, TR, TT, TZ, UA, UG, US, UZ, VC, VN, ZA, ZM, ZW.

(84) Designated States (unless otherwise indicated, for every kind of regional protection available): ARIPO (BW, GH, GM, KE, LS, MW, MZ, NA, SD, SL, SZ, TZ, UG, ZM, ZW), Eurasian (AM, AZ, BY, KG, KZ, MD, RU, TJ, TM), European (AT, BE, BG, CH, CY, CZ, DE, DK, EE, ES, FI, FR, GB, GR, HU, IE, IS, IT, LT, LU, LV, MC, NL, PL, PT,

[Continued on next page]

(54) Title: SPITTER GRAPPLER

(57) Abstract: A wood splitting grappler is provided which may grab debris, split debris and move the debris to a desired location such as a materials reducing machine for further processing or disposition.

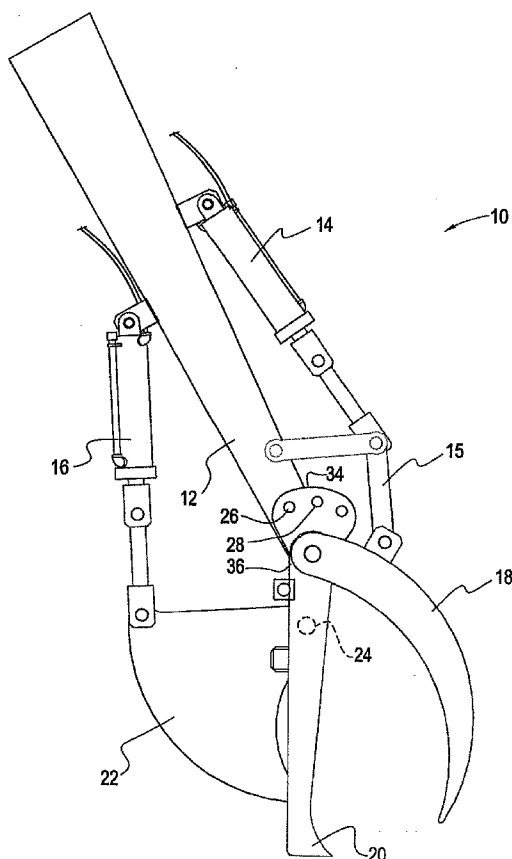

WO 2007/070802 A2



RO, SE, SI, SK, TR), OAPI (BF, BJ, CF, CG, CI, CM, GA, GN, GQ, GW, ML, MR, NE, SN, TD, TG).

*For two-letter codes and other abbreviations, refer to the "Guidance Notes on Codes and Abbreviations" appearing at the beginning of each regular issue of the PCT Gazette.*

**Published:**

— *without international search report and to be republished upon receipt of that report*

## **SPLITTER GRAPPLER**

### **Cross-Reference to Related Applications**

The present application is a continuation-in-part of and claims priority to U.S. Provisional Patent Application No. 60/750,239, filed December 13, 2005, entitled "WOOD SPLITTING GRAPPLE," the entire disclosure of which is hereby  
5 incorporated by reference in its entirety.

### **FIELD**

The present invention relates generally to the field of attachments for excavators, timber harvesting, and clearing equipment, and more particularly to a  
10 wood splitting grapple attachment adapted to controllably handle and split stumps and other debris.

### **BACKGROUND**

Harvesting equipment, excavators, and other implements (referred to herein generically as excavators) are often used to clear areas of wood, stumps  
15 and other debris. These machines often are responsible for picking up the debris and feeding it into a grinder, recycler or other machine adapted to size reduce material. When a stump, chunk, log or other piece of debris is encountered that is too big for the size reducing machine being used, such debris must be split into smaller pieces, or must be handled separately. Some machines may have a  
20 wood splitter attachment that replaces a grapple device on an excavator, for example, that will accomplish the splitting function. These splitter attachments, however, are not adapted for conveniently grabbing and loading the debris into the size reducing machine for further processing.

### **BRIEF DESCRIPTION OF THE DRAWINGS**

25 Embodiments of the present invention will be readily understood by the following detailed description in conjunction with the accompanying drawings. Embodiments of the invention are illustrated by way of example and not by way of limitation in the figures of the accompanying drawings.

**FIGS. 1A, 1B, and 1C** illustrate respective side, front perspective and rear  
30 perspective views in accordance with various embodiments of the present invention;

**FIG. 2** illustrates partial side and partial schematic view in accordance with various embodiments of the present invention;

**FIG. 3** illustrates a side view in accordance with various embodiments of the present invention;

5 **FIG. 4** illustrates a side view in accordance with various embodiments of the present invention;

**FIG. 5** illustrates a perspective view in accordance with various embodiments of the present invention; and

10 **FIGS. 6A** and **6B** illustrate perspective views in accordance with various embodiments of the present invention.

### **DETAILED DESCRIPTION OF EMBODIMENTS OF THE INVENTION**

In the following detailed description, reference is made to the accompanying drawings which form a part hereof, and in which is shown by way of illustration embodiments in which the invention may be practiced. It is to be understood that other embodiments may be utilized and structural or logical changes may be made without departing from the scope of the present invention. Therefore, the following detailed description is not to be taken in a limiting sense, and the scope of embodiments in accordance with the present invention is defined by the appended claims and their equivalents.

20 Various operations may be described as multiple discrete operations in turn, in a manner that may be helpful in understanding embodiments of the present invention; however, the order of description should not be construed to imply that these operations are order dependent.

25 The description may use perspective-based descriptions such as up/down, back/front, and top/bottom. Such descriptions are merely used to facilitate the discussion and are not intended to restrict the application of embodiments of the present invention.

30 For the purposes of the description, a phrase in the form "A/B" means A or B. For the purposes of the description, a phrase in the form "A and/or B" means "(A), (B), or (A and B)." For the purposes of the description, a phrase in the form "at least one of A, B, and C" means "(A), (B), (C), (A and B), (A and C), (B and C),

or (A, B and C).” For the purposes of the description, a phrase in the form “(A)B” means “(B) or (AB)” that is, A is an optional element.

The description may use the phrases, “in various embodiments,” “in an embodiment,” or “in embodiments,” which may each refer to one or more of the same or different embodiments. Furthermore, the terms “comprising,” “including,” “having,” and the like, as used with respect to embodiments of the present invention, are synonymous.

The terms “coupled” and “connected,” along with their derivatives, may be used. It should be understood that these terms are not intended as synonyms for each other. Rather, in particular embodiments, “connected” may be used to indicate that two or more elements are in direct physical or electrical contact with each other. “Coupled” may mean that two or more elements are in direct physical or electrical contact. However, “coupled” may also mean that two or more elements are not in direct contact with each other, but yet still cooperate or interact with each other.

Embodiments of the present invention may include an attachment for an excavator that may function as a grapple for loading or handling of debris, a splitter for oversized debris, and/or an attachment that is adapted to grab, split, and load a piece of oversized debris into a size reducing machine, or otherwise dispose thereof, in an efficient and safe manner.

In various embodiment of the present invention, a debris splitting grapple may replace the bucket that normally attaches to the stick of an excavator, for example. In one embodiment, the existing hydraulic cylinder that attaches to the bucket by way of the existing excavator linkage may power the front of the grapple. As many excavators and other machines have an auxiliary hydraulic circuit and cylinder, often used to operate a thumb, for example, the auxiliary or thumb cylinder may either attach to the rear portion of the grapple, and/or to the splitter knife. Depending on which component the auxiliary cylinder is attached will determine which component is controlled by actuation of the auxiliary cylinder.

**FIG. 1A** is a side view and **FIGS. 1B** and **1C** are perspective views illustrating various embodiments in accordance with the invention. A splitting grapple **10**, such as a grapple for splitting wood, may be adapted to be

controllably attached to an excavator stick **12**. The excavator stick **12** may be of the type having a front hydraulic cylinder **14** and a rear, or auxiliary, hydraulic cylinder **16**. The splitting grapple **10** may include a front grapple portion **18** adapted to be pivotally coupled to the stick **12**. The front grapple portion **18** may be further adapted to be pivoted by the front hydraulic cylinder **14**, via an excavator linkage **15**.

A rear grapple portion **20** may be provided and also adapted to be pivotally coupled to the stick **12**. The front grapple portion **18** and the rear grapple portion **20** may be further adapted to cooperate in order to grab an object (not shown). A knife **22** may be adapted to be, directly or indirectly, coupled to the stick **12** and may be adapted to pivot with respect to, or in conjunction with, the rear grapple portion **20** to split and/or to cut the object. At least one of the rear grapple portion **20** and the knife **22** may be adapted to be operatively coupled with the rear hydraulic cylinder **16** to effect the pivoting of one or both of the rear grapple portion **20** and the knife **22**. As illustrated, various embodiments may include the knife **22** pivotally coupled with the rear grapple portion **20** at hinge point **24**.

In one embodiment where the auxiliary, or back, cylinder **16** may be coupled to the knife, the rear portion of the grapple may be fixed or pinned at a point relative to the stick. In one embodiment, a member that fixes the rear grapple portion to the excavator stick may have multiple pin locations to vary the operating angle.

In various embodiments, a releasable locking mechanism may be used to engage and disengage the knife with the rear grapple portion **20**. In such embodiments, the auxiliary cylinder on the stick may be attached to the knife, and thus control both the grapple and the knife. A variety of manual and automatic releasable locking mechanisms may be used, including, but not limited to a sliding pin that may be actuated hydraulically, or pneumatically, or the like, to lock and unlock the knife to the grapple portion as desired. There may be several locking positions available so that the rear portion of the grapple can be locked at different angles. In various embodiments, the knife may be selectively locked and unlocked to the excavator stick.

Referring to **FIG. 1C**, the knife **22** may include a number of holes **30** adapted to received a pin **32** adapted for extension and retraction in piston **33**. The piston **33** may be rigidly coupled with rear grapple portion **20**.

When the rear grapple portion is locked to the knife, the rear grapple portion and the knife may rotate together. Such a configuration may allow normal grapple operation, such as loading the grinder. When the rear grapple portion is locked to the excavator stick, the grapple portion may remain stationary and the rear cylinder may force the knife forward through the rear grapple portion and into the wood.

For example, as illustrated in **FIG. 1A** a flange **34** may be attached or made integral with a first end **36** of the rear grapple portion **20**. The flange **34** may include multiple openings **26** adapted to receive a retractable pin **28** which may be, for example, mounted on the stick **12** or adapted to engage the stick **12**. The pin **28** may be actuated via various methods including but not limited to, manually, hydraulically, and/or pneumatically, and may also be controlled by mechanical linkage, electrical coupling and/or wirelessly.

In another embodiment, the rear cylinder **16** may be coupled to the rear grapple portion **20**, and the knife **22** may be pinned or fixed relative to rear grapple portion **20**, or the stick **12**. Where the knife **22** is fixed to the rear portion of the grapple, the amount of knife that may be adapted to engage a piece of debris may be controllably adjusted as desired.

In various embodiments, a knife guide for the knife may be built into the rear grapple portion. For example, as illustrated in **FIG. 1C**, a knife guide **60** may include a first guide member **62** disposed adjacent a first side **64** of the knife **22** and a second guide member **66** disposed opposite the first guide member **62** and adjacent a second side **68** of the knife **22**. The knife guide **60** may be used as both a guide for the knife, as well as to provide for lateral support for the knife **22**. In one embodiment, during full retraction of the knife, the knife may still be engaged with the guide. Such support and guidability may provide added stability and functionality by allowing the knife **22** to withstand higher forces that may be encountered during a splitting operation.

In various embodiments of the present invention, where only two hydraulic circuits are provided on a stick, a hydraulic valve may be used to shift the auxiliary hydraulic circuit to operate one or more knife actuating cylinders or one or more rear grapple portion actuating cylinders. The hydraulic valve may be located on  
5 the excavator machine, on the stick, or on the splitting grapple, and may be operated in a variety of ways, including, but not limited to electrically, manually, and the like. With such a valve, an oversized object may be gripped by both portions of the grapple when the valve is positioned such that the auxiliary circuit is operating the auxiliary cylinder controlling the rear grapple portion . The valve  
10 may then be shifted to the knife cylinder in order to complete the splitting of the object, and then shifted rear to resume grapple operation.

Such use of a valve arrangement and/or other control device that is adapted to switch the piece in which the auxiliary circuit controls at a given time may be a cost-effective solution to enabling controlling of all three parts without  
15 adding a separate third hydraulic circuit to the stick. In another embodiment, however, a third hydraulic circuit and a third cylinder may be provided, such that both the rear portion of the grapple and the splitter knife may be independently and controllably actuated.

**FIG. 2** is a partial side view and partial schematic view illustrating various  
20 embodiments in accordance with the invention. As illustrated, a splitter grapppler **110** may include a first grapppler portion **118** which may be operatively coupled with an excavator stick **112** for pivoting relative thereto, and adapted to be actuated by a first hydraulic cylinder **114**. A second grapppler portion **120** may also be operatively coupled to the excavator stick **112** and adapted to pivot relative  
25 thereto. A knife **122** may be pivotally coupled to the second grapppler portion **120** as illustrated. In other embodiments the knife **122** may be pivotally coupled directly to the stick **112**. One or more first auxiliary cylinders **116** may be adapted to actuate the second grapppler portion **120**, and one or more second auxiliary cylinders **116'** may be adapted to actuate the knife **122**. Power from auxiliary  
30 hydraulic lines **150** from the excavator (not shown) may be selectively directed to one of either the first auxiliary hydraulic cylinder **116** or the second auxiliary hydraulic cylinder **116'**, with valves **152** via first supplemental auxiliary hydraulic

lines **154**, and second supplemental auxiliary hydraulic lines **156**. A controller **158** may be adapted to control the flow of hydraulic fluid with valves **152**.

**FIG. 3** is a side view illustrating various embodiments in accordance with the invention. When an oversized object is picked up, the operator may curl the  
5 grapple so that the front of the grapple rests on the ground **80**, then actuate the knife **22** to split the object by forcing the knife into the wood. The front of the grapple may be supported by the ground **80** during splitting.

In one embodiment, the knife may share the same pivot point as the grapple portions. In another embodiment, the knife may pivot on a different pivot  
10 point than the grapple portions. It can be appreciated that the grapple shape and size can vary depending on the particular application. For example, while the front grapple portion may be generally curved, the rear portion may be straight, curved or otherwise adapted for use with the debris being handled.

**FIG. 4** is a side view illustrating various embodiments in accordance with  
15 the invention. Portions have been removed for illustration. A splitter grapppler **210** may include a curved front grapple portion **218** pivotally coupled with a stick **212** of an excavator. A rear grapple portion **220** may also be coupled with a stick **212** and may also be curved. A knife **222** may be pivotally coupled with the rear grapple portion **220**.

**FIG. 5** is a perspective view illustrating various embodiments in accordance  
20 with the invention. A splitter grapppler **310** may include a curved front grapple portion **318** pivotally coupled with a stick **312** of an excavator, and a curved rear grapple portion **320** also be coupled with a stick **312**. Each of the front and rear grapple portions **318**, **320** may be adapted to pivot about a pivot axis **370**. A  
25 knife **322** may be coupled directly to the stick **312** and may be adapted to pivot about the same pivot axis **370**. The knife **322** may include an arm **372** coupled with a knife body **374** at a first end and adapted to pivot on the stick at a second end. In various embodiments, the arm **372** may be made integral with the knife body or attached thereto using various methods of attachment.

**FIGS. 6A** and **6B** are perspective views illustrating various knives **322** and  
30 **322'** in accordance with various embodiments of the invention. The figures illustrate two of many various shapes and configurations that may be possible in

accordance with various embodiments of the invention. For example, the coupling of the blade may be varied to better accommodate different hydraulic systems, modify the knife path, etc. The configuration and/or material of the blade and/or cutting portion may likewise be varied depending on a variety of factors, such as  
5 debris being split, grapple configurations, etc.

In various embodiments, the front grapple portion may be the portion in which the knife engages, moves relative to, and/or fixes to, and the rear grapple portion may be the portion that moves independent of a relationship with the knife.

In one embodiment, a wood splitting grapple adapted to controllably attach  
10 to an excavator type stick may be provided that includes:

A front grapple half pivotally coupled to the stick at a first pivot point and movable about the first pivot point by a first hydraulic cylinder;

A rear grapple half operationally coupled to the stick and pivotable about the first pivot point, the front grapple half and the rear grapple half adapted to  
15 cooperate in order to grab a piece of debris; and

A knife operationally coupled to stick and pivotable about a second pivot point (which may be the same as the first pivot point), the knife adapted to move with respect to or in conjunction with the rear grapple half to split the piece of debris.

20 Although specific embodiments have been illustrated and described herein for purposes of description of the preferred embodiment, it will be appreciated by those of ordinary skill in the art that a wide variety of alternate and/or equivalent implementations may be substituted for the specific embodiment shown and described without departing from the scope of the present invention. Those with  
25 skill in the art will readily appreciate that the present invention may be implemented in a very wide variety of embodiments. This application is intended to cover any adaptations or variations of the embodiments discussed herein.

Therefore, it is manifestly intended that this invention be limited only by the claims and the equivalents thereof:

### CLAIMS

What is claimed is:

1. A debris splitting grapple adapted to be controllably attached to an excavator stick of the type having a first hydraulic cylinder and a second hydraulic cylinder comprising:
  - 5 a first grapple portion adapted to be pivotally coupled with the stick and adapted to be pivoted by the first hydraulic cylinder;  
a second grapple portion adapted to be coupled with the stick, the first grapple portion and the second grapple portion adapted to cooperate in order to grab an object of debris; and
  - 10 a knife adapted to be coupled with the stick and adapted to pivot with respect to or in conjunction with the second grapple portion to split and/or cut the object, at least one of the second grapple portion and/or the knife operatively coupled to a second cylinder to effect the pivoting of one or both of the second grapple portion and the knife.
- 15 2. The debris splitting grapple of claim 1 wherein the second grapple portion is pivotally coupled to the stick.
3. The debris splitting grapple of claim 1 wherein the second grapple portion is movably fixed relative to the stick.
4. The debris splitting grapple of claim 3 wherein the second grapple portion  
20 includes a fixing member that allows the second grapple portion to be fixed relative to the stick at a number of predetermined positions.
5. The debris splitting grapple of claim 1 wherein the knife is pivotally coupled to the second grapple portion and/or the stick.
6. The debris splitting grapple of claim 1 wherein the knife is fixed such that it  
25 does not move relative to the second grapple portion.

7. The debris splitting grapple of claim 6 wherein the second cylinder is coupled with the knife and is adapted to pivot the rear grapple portion relative to the stick.
8. The debris splitting grapple of claim 6 wherein the knife is adapted to be  
5 fixed to the second grapple portion and/or stick at a number of predetermined positions.
9. The debris splitting grapple of claim 1 further comprising a releasable locking mechanism to be used to engage and disengage the knife with the second grapple portion.
- 10 10. The debris splitting grapple of claim 1 wherein the rear hydraulic cylinder is coupled to and actuates the second grapple portion, and further comprising a third hydraulic cylinder coupled to and that actuates the knife.
11. The debris splitting grapple of claim 10, further comprising one or more valves adapted to selectively control hydraulic power to one of the second and  
15 third cylinders.
12. The debris splitting grapple of claim 1 wherein the excavator stick include a main hydraulic line and an auxiliary hydraulic line, the auxiliary hydraulic line is bifurcated to selectively manipulate the second grapple portion and the knife.
13. The debris splitting grapple of claim 1 further comprising a knife guide  
20 coupled with the second grapple portion.
14. The debris splitting grapple of claim 1, wherein the first grapple portion is a front grapple half and the second grapple portion is a rear grapple half.
15. The debris splitting grapple of claim 1, wherein the first grapple portion and the second grapple portion are pivotally coupled to the stick at a first pivot point;  
25 and the knife is pivotable about a second pivot point, the knife adapted to move with respect to or in conjunction with the second grapple half to split the debris.

16. The debris splitting grapppler of claim 14 wherein the first pivot point is coaxial with the second pivot point.

17. The debris splitting grapppler of claim 1 further comprising a knife support coupled with the second grapppler element and able to at least partially support the  
5 knife while the knife pivots relative to the rear grapppler element.

18. An apparatus, comprising:

a first grapppler element adapted to be pivotally coupled to an excavator stick and actuatable for pivoting movement by a first hydraulic cylinder coupled to the excavator stick;

10 a second grapppler element adapted to be pivotally coupled to the excavator stick and able to cooperate with the first grapppler element to grab an object; and

a knife adapted to pivot relative to the first grapppler element and adapted to contact the object, one or both of the second grapppler element and the knife actuatable for pivoting movement by a second hydraulic cylinder coupled to the  
15 excavator stick.

19. The apparatus of claim 18 further comprising a knife support coupled with the second grapppler element and able to at least partially support the knife while the knife pivots relative to the rear grapppler element.

20. The apparatus of claim 18 further comprising a third hydraulic cylinder  
20 coupled with and able to effect pivoting of one of the second grapppler element and the knife, and the second hydraulic cylinder coupled with and able to effect pivoting of the other of the second grapppler element and the knife.

21. The apparatus of claim 20 further comprising a valve arrangement disposed to selectively provide hydraulic power and effect actuation of the second  
25 hydraulic cylinder or the third hydraulic cylinder.

22. The apparatus of claim 18 wherein one of the second grapppler element and the knife are fixable in place relative to the excavator stick while the other of the second grapppler element and the knife are actuatable for pivoting by the second hydraulic cylinder.

23. An excavator of the type having a stick, a primary hydraulic cylinder, and an auxiliary hydraulic cylinder, comprising:

a first grapple element pivotally coupled to the stick of the excavator and actuatable for pivoting movement by the primary hydraulic cylinder;

5 a second grapple element pivotally coupled to the excavator stick and able to cooperate with the first grapple element to grab an object; and

a knife pivotally coupled to one of the excavator stick or the second grapple element able to contact the object for splitting the object, one of the second grapple element and the knife being actuatable by the auxiliary hydraulic  
10 cylinder.

24. The excavator of claim 23 wherein the excavator includes an auxiliary hydraulic circuit, and further comprising a second auxiliary hydraulic cylinder, the other of the second grapple element and the knife being actuatable by the second auxiliary hydraulic cylinder, and a valve arrangement for selectively  
15 providing hydraulic power from the auxiliary hydraulic circuit to one of the auxiliary hydraulic cylinder and the second auxiliary hydraulic cylinder.

25. The excavator of claim 24 wherein the second auxiliary hydraulic cylinder is a pair of second auxiliary hydraulic cylinders each coupled with the auxiliary hydraulic circuit for actuation.

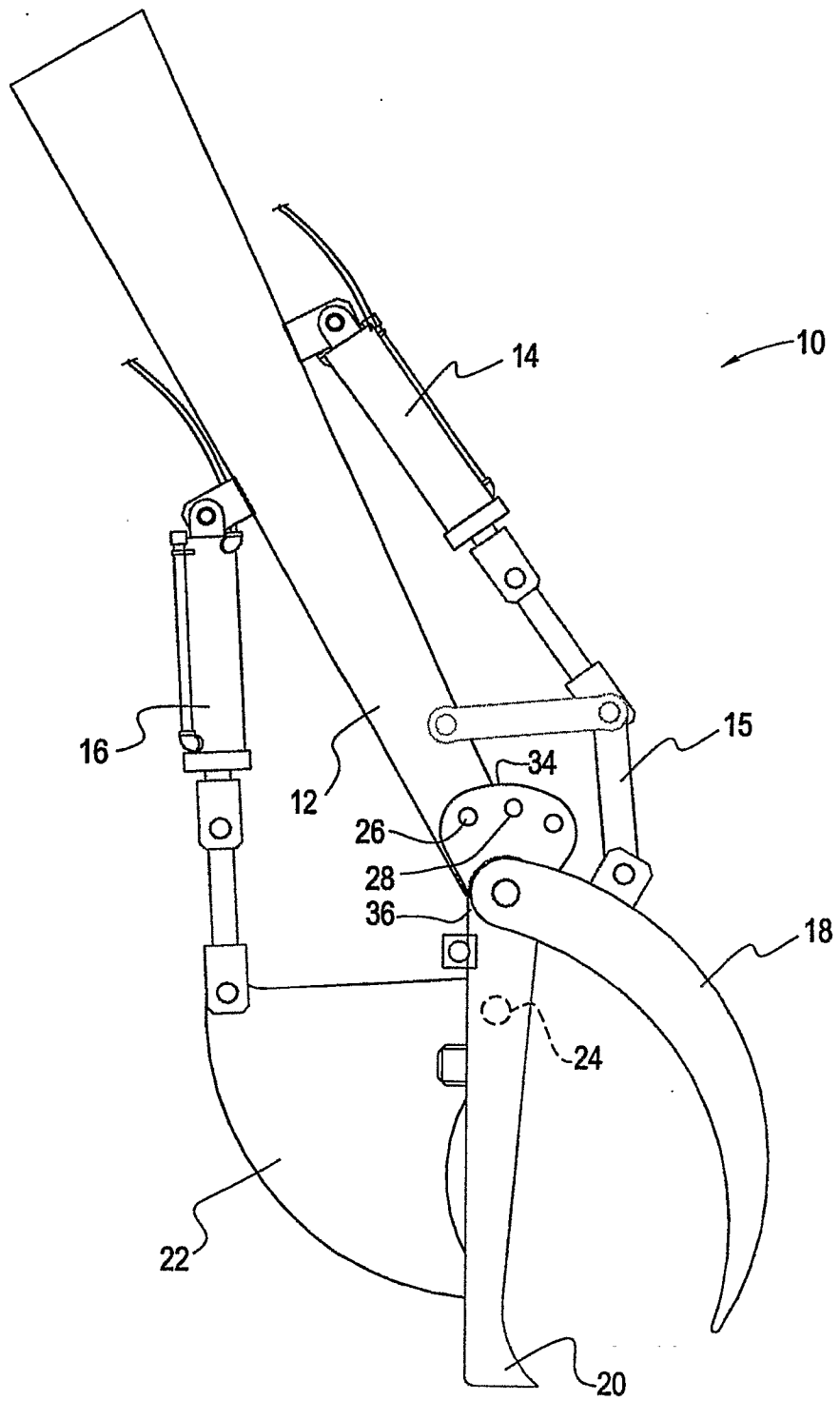

FIG. 1A

10

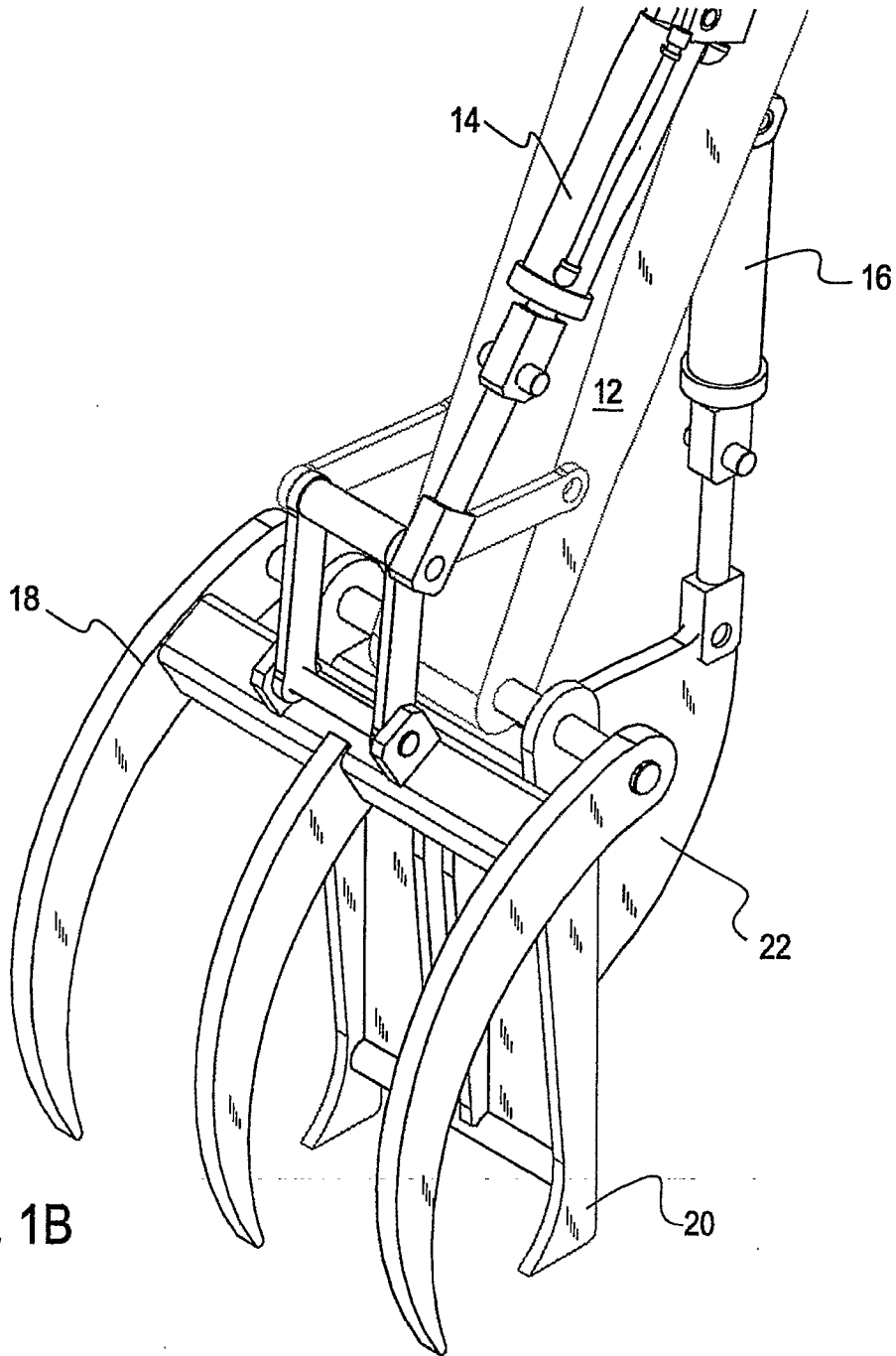

FIG. 1B

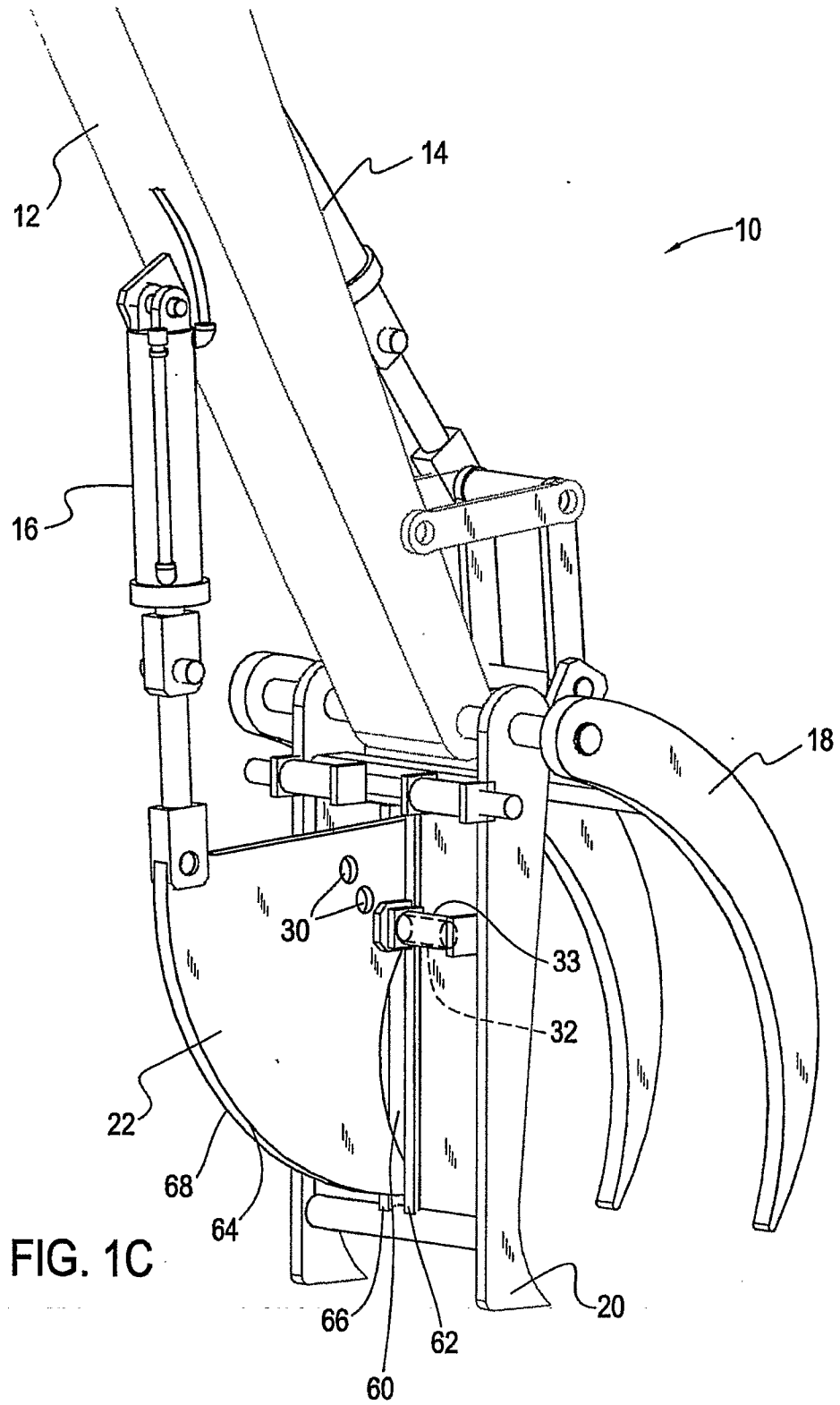

FIG. 1C

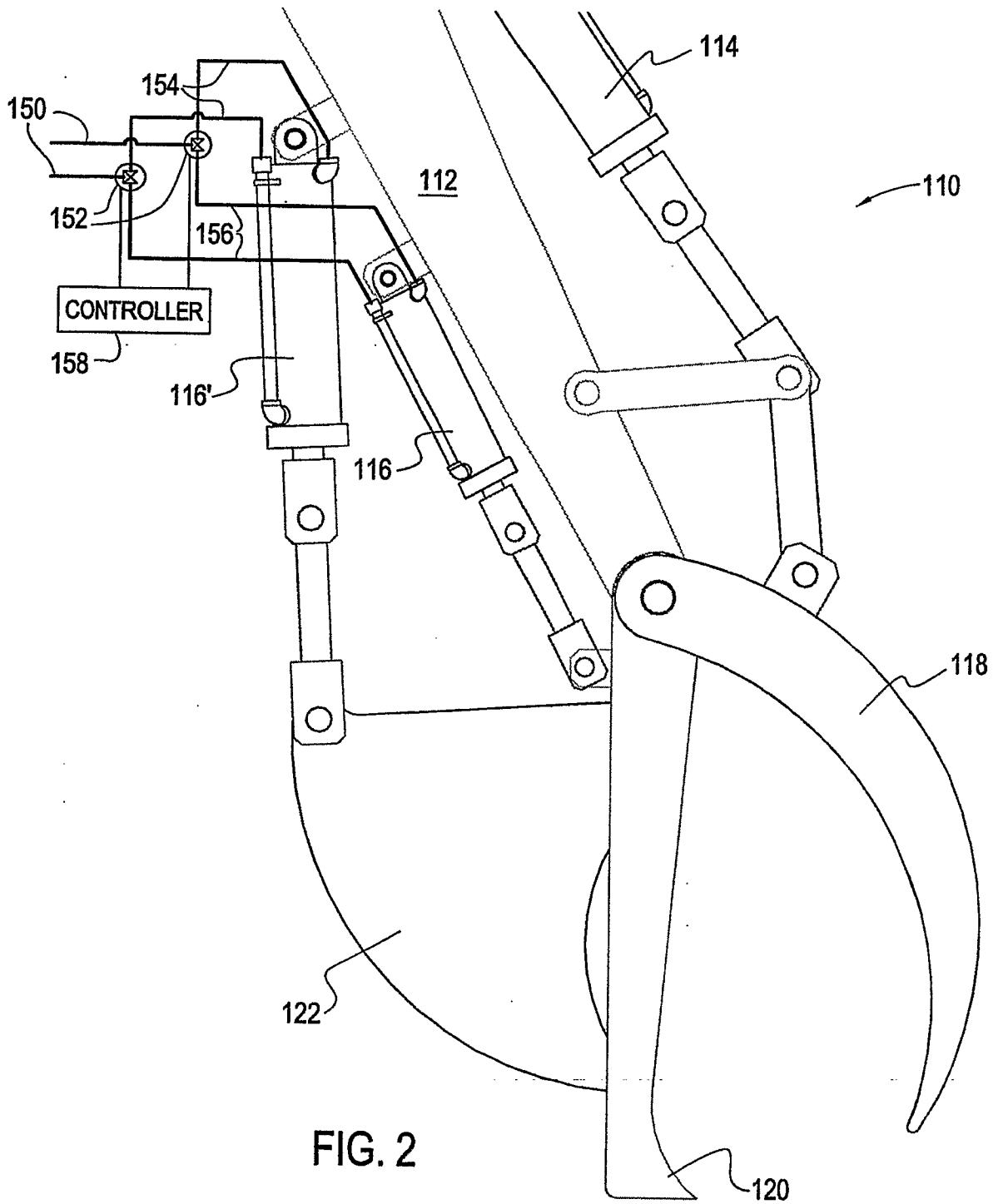

FIG. 2

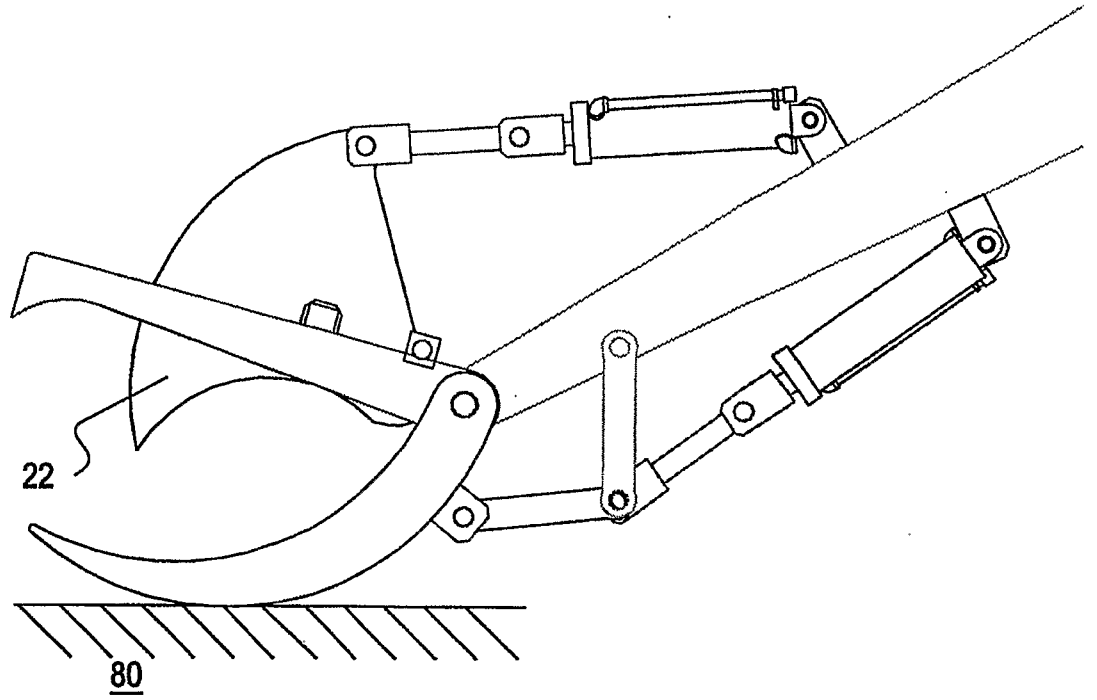

FIG. 3

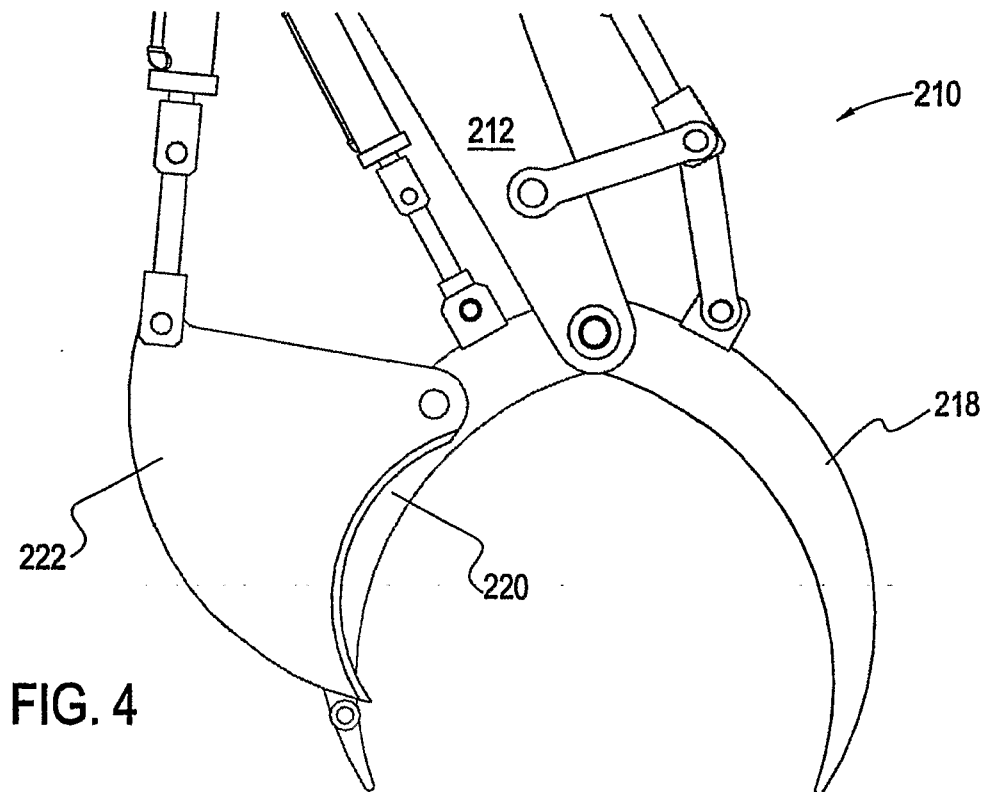

FIG. 4

6/6

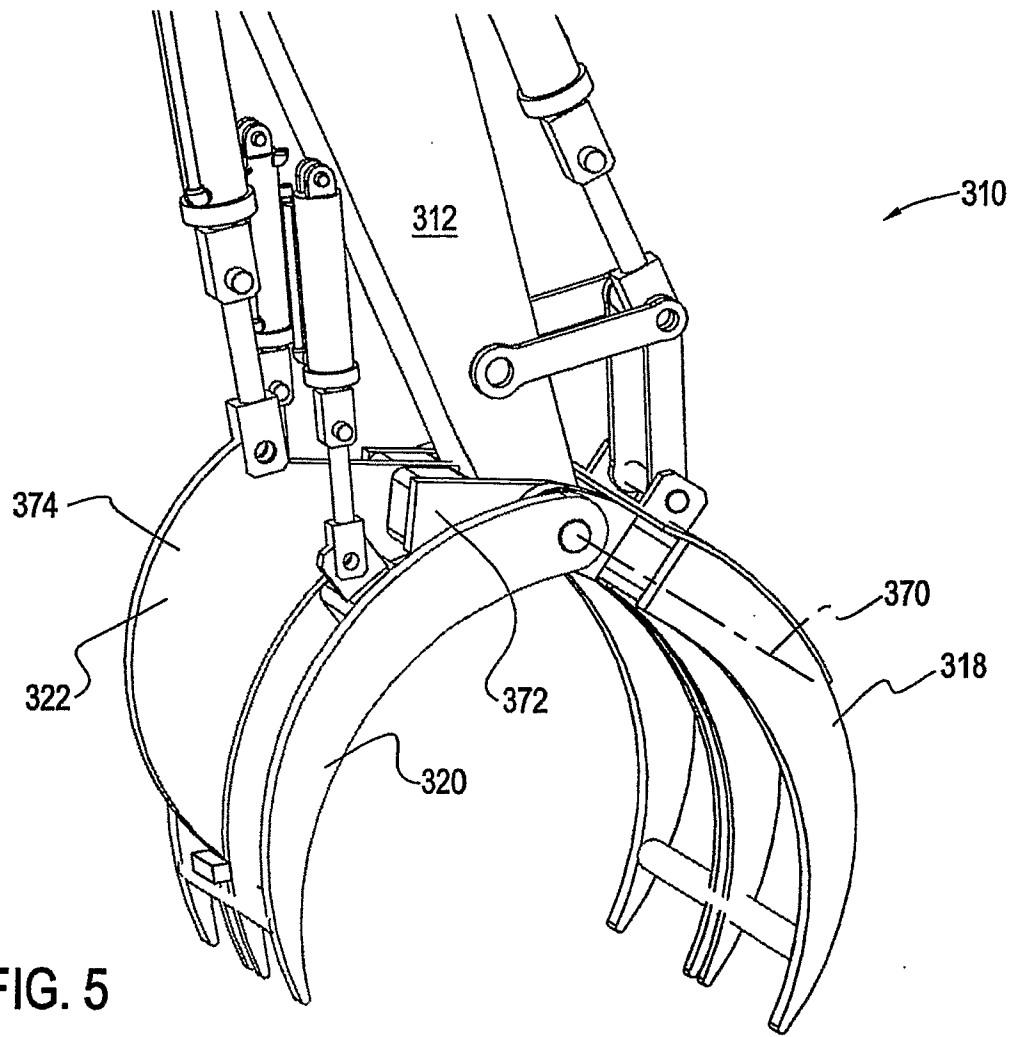

FIG. 5

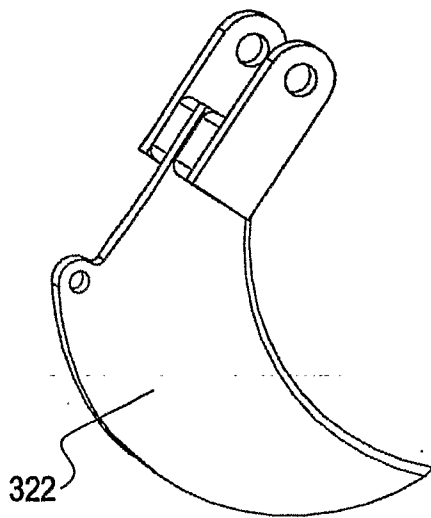

FIG. 6A

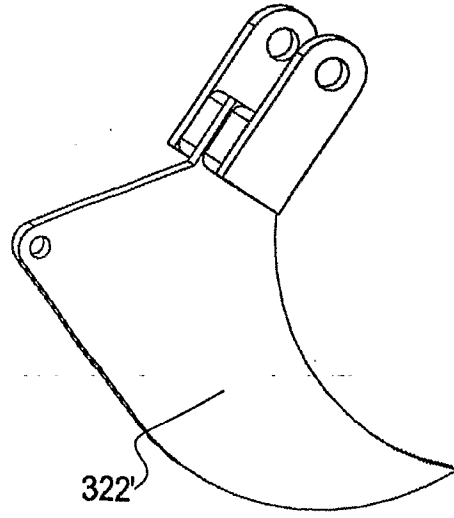

FIG. 6B