

(No Model.)

J. ADAMS.
HYDROCARBON BURNER.

No. 404,148.

Patented May 28, 1889.

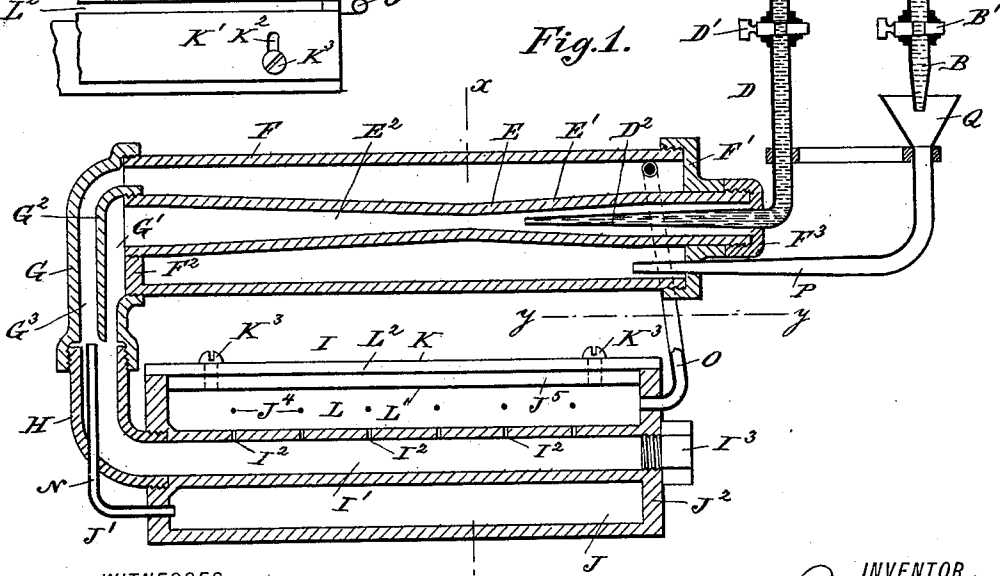
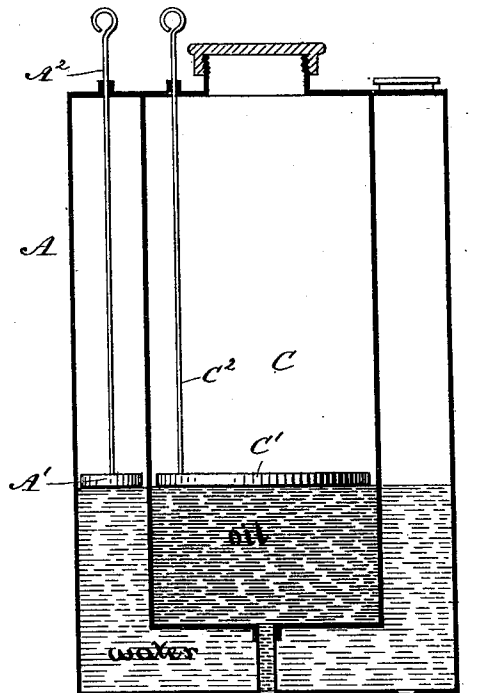
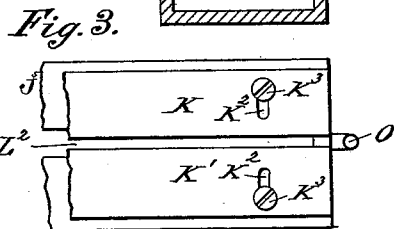
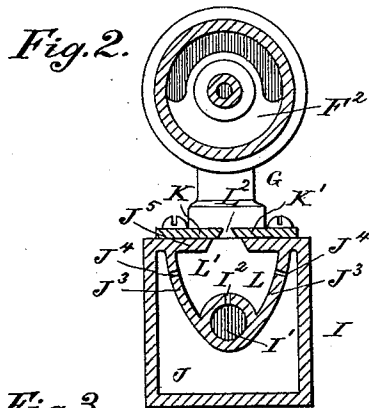

WITNESSES:
D. C. Reusch.
C. Sedgwick

INVENTOR,
J. Adams
BY Munn & Co

ATTORNEYS.

UNITED STATES PATENT OFFICE.

JOHN ADAMS, OF NASHVILLE, TENNESSEE.

HYDROCARBON-BURNER.

SPECIFICATION forming part of Letters Patent No. 404,148, dated May 28, 1889.

Application filed May 1, 1888. Serial No. 272,409. (No model.)

To all whom it may concern:

Be it known that I, JOHN ADAMS, of Nashville, in the county of Davidson and State of Tennessee, have invented a new and Improved Hydrocarbon-Burner, of which the following is a full, clear, and exact description.

The object of the invention is to provide a new and improved hydrocarbon-burner which is simple and durable in construction and very effective in operation, utilizing steam and oil to the fullest advantage.

The invention consists of certain parts and details and combinations of the same, as will be fully described hereinafter, and then pointed out in the claims.

Reference is to be had to the accompanying drawings, forming a part of this specification, in which similar letters of reference indicate corresponding parts in all the figures.

Figure 1 is a sectional side elevation of the improvement. Fig. 2 is a transverse sectional elevation of part of the same on the line *x x* of Fig. 1, and Fig. 3 is a sectional plan view of part of the improvement on the line *y y* of Fig. 1.

The improved hydrocarbon-burner is provided with a tank, A, containing water, on the top of which is held a float, A', secured to a rod, A², extending to the top of the tank A and serving to indicate the level of the water in the tank A. From the bottom of the tank A leads an outlet-pipe, B, provided with a cock, B', for opening and closing said outlet-pipe B.

Inside of the tank A is secured another tank, C, containing oil, on the top of which is held a float, C', provided with an upwardly-extending rod, C², passing through the top of the tank C and serving to indicate the level of the oil in the tank C. From this tank C leads a pipe, D, provided with a cock, D', for opening and closing said pipe D, and the lower part of the pipe D is formed into a conical end, D², bent at right angles to the pipe D and extending into a conical part, E', of the tube E, provided with a second cone, E², so as to form of said tube E a double cone, the upper ends of the cones being joined together, as shown in Fig. 1.

The tube E is held centrally in the steam-generator F, provided on one end with a removable head, F', and a fixed part, F², sur-

rounding and supporting the end of the cone E² of the tube E; as is plainly shown in Figs. 1 and 2. In the cap F' is held the outer end of the cone E' of the tube E, and on the extreme outer end of this cone E' screws a cap, F³, through which passes the cone-shaped end D² of the pipe D. A pipe, G, is secured to the end of the steam-generator F opposite the pipe D, and the said pipe G is provided with a central partition, G², which divides said pipe G into the compartments G' and G³, of which the former connects with the cone E², and the compartment G³ connects with the top of the steam-generator F, as illustrated in Fig. 1.

The pipe G extends downward and connects with a pipe, H, leading to the central pipe, I', of the burner I, provided with a casing, J, inclosing said central pipe, I'. The latter is provided on top with a number of openings, J², leading to a combustion-chamber, L, formed by the partitions J³, secured to the top plate, J⁵, of the casing J and extending to and connecting with the central pipe, I'. (See Fig. 2.)

In the partitions J³ are formed rows of apertures J⁴, connecting the casing J with the mixing-chamber L. The latter is provided in the top J⁵ of the casing J with an opening, L', extending throughout the length of the casing and connecting with a slit, L², formed by the top plates, K and K', held adjustably on the top J⁵ of the casing J by means of set-screws K³, passing through transverse slots K² in the said plates K and K'. (See Fig. 3.) Thus by loosening the set-screws K³ said plates K and K' may be moved toward or from each other, so as to increase or diminish the size of the slit L² formed by the said plates.

A pipe, N, opens into the lower end of the compartment G³ of the pipe G and leads into the bottom of the casing J, and a pipe, O, connects the top of the steam-generator F with the mixing-chamber L. Into the bottom of the steam-generator F leads a conical pipe, P, bent upward and provided with a funnel, Q, into which discharges the lower end of the pipe B, connected with the tank A. The outer end of the central pipe, I', is closed by a screw-cap, I³, which can be removed to clean the tube I' in case this is necessary.

The operation is as follows: The tanks A

and C are located above the steam-generator F, so that when the operator opens the cock D' the oil from the tank C passes under pressure through the pipe D into the tube E and is sprayed in the latter. The water from the tank A passes into the funnel Q when the cock B' is opened, and then passes through the pipe P into the steam-generator F. As the latter is heated, the water is converted into steam and passes through the compartment G³ in the pipe G, so as to mix at the lower end of the partition G² with the oil sprayed into the pipe E and passing into the compartment G' of the said pipe G. The oil on passing through the heated tube E is likewise heated, so that the heated mixture of steam and oil passes into the pipe H and from the latter into the central tube, I', from which it passes through the apertures I² into the mixing-chamber L. At the same time the steam from the generator F will pass into the said mixing-chamber L by means of the pipe O, and steam will also pass from the compartment G³ of the tube G into the casing J by the pipe N. The steam in the casing J passes through the apertures J⁴ into the mixing-chamber L, and the entire mixture in the mixing-chamber is ignited at the slit L², so that the flame heats the generator F and produces the necessary steam in the generator F. The heat arising from the burning of the mixture in the slit L² can be utilized for various purposes—heating rooms, cooking, &c.

It will be seen that the steam admitted through the pipe N into the casing J and passing through the apertures J⁴ prevents the oil in the mixture of oil and steam from coking, so that a complete combustion takes place, and very little, if any, residue is left.

Having thus fully described my invention, I claim as new and desire to secure by Letters Patent—

1. In a hydrocarbon-burner, the combination, with a steam-generator provided in its interior with a pipe into which the oil is sprayed, of a pipe divided by a partition into two compartments connected, respectively, with the said steam-generator and its central pipe, and a burner consisting of an apertured pipe connected with the lower end of the said double pipe, a casing inclosing the said perforated pipe, apertured partitions extending in the said casing to the said central pipe to form a mixing-chamber, plates held adjustably on the slotted top of the said casing, and a steam-pipe leading from the said steam-generator to the interior of the said mixing-chamber, substantially as shown and described.

2. In a hydrocarbon-burner, the combination, with a steam-generator provided in its

interior with a pipe into which the oil is sprayed, of a pipe divided by a partition into two compartments connected, respectively, with the said steam-generator and its central pipe, and a burner consisting of an apertured pipe connected with the lower end of the said double pipe, a casing inclosing the said perforated pipe, apertured partitions extending in the said casing to the said central pipe to form a combustion-chamber, plates held adjustably on the slotted top of the said casing, a steam-pipe leading from the said steam-generator into the interior of the said mixing-chamber, and a second steam-pipe leading from the steam-compartment of the double pipe into the said casing, substantially as shown and described.

3. In a hydrocarbon-burner, the combination, with a water-tank and an oil-tank, each containing a float and each provided with a discharge-pipe, of a tube having a double cone shape, and into which discharges said oil-discharge pipe, a steam-generator surrounding the said tube and connected with the said water-outlet pipe, a double pipe held on the end of the said steam-generator and having two compartments opening, respectively, into the said tube and the said steam-generator, a burner consisting of a pipe connected with the said double pipe and having openings in its top, a casing surrounding the said pipe and having perforated partitions extending to the said perforated pipe, so as to form a mixing-chamber, and plates held adjustably on the slotted top of the said casing, substantially as shown and described.

4. In a hydrocarbon-burner, the combination, with a water-tank and an oil-tank, each containing a float and each provided with a discharge-pipe, of a tube having a double cone shape, and into which discharges said oil-discharge pipe, a steam-generator surrounding the said tube and connected with the said water-outlet pipe, a double pipe held on the end of the said steam-generator and having two compartments opening, respectively, into the said tube and the said steam-generator, a burner consisting of a pipe connected with the said double pipe and having openings in its top, a casing surrounding the said pipe and having perforated partitions extending to the said perforated pipe, so as to form a mixing-chamber, plates held adjustably on the slotted top of the said casing, and a steam-pipe leading from the said generator to the said combustion-chamber, substantially as shown and described.

JOHN ADAMS.

Witnesses:

D. C. SCALES,
SIDNEY GOODE.