

Aug. 25, 1936.

F. H. GROVES

2,052,402

DESTRUCTIBLE CONTAINER

Original Filed June 23, 1934

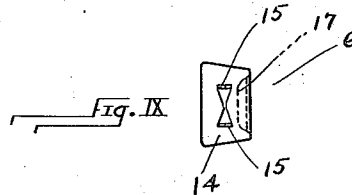
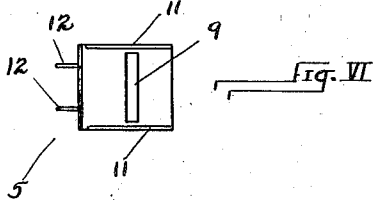
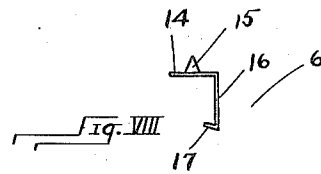
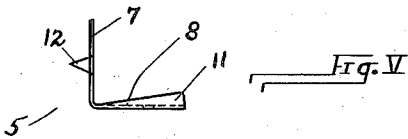
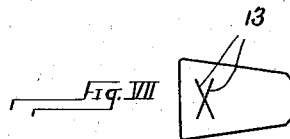
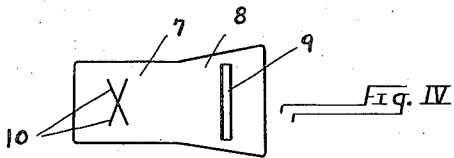
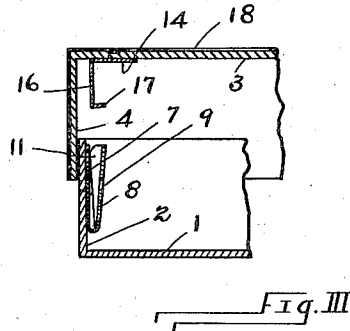
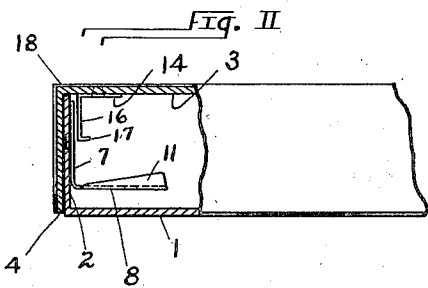
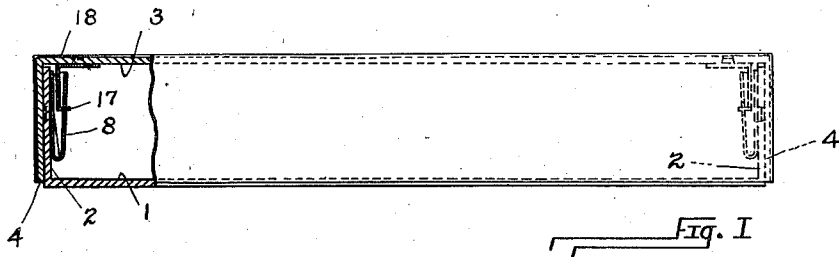

INVENTOR
Frederick H. Groves
BY *Christy and Wharton*
ATTORNEYS.

UNITED STATES PATENT OFFICE

2,052,402

DESTRUCTIBLE CONTAINER

Frederick H. Groves, Dormont, Pa.

Application June 23, 1934, Serial No. 732,054

Renewed January 29, 1936

5 Claims. (Cl. 229-47)

This invention relates to a destructible container and to automatic locking means arranged to require the destruction of the container, in order that there may be removed from it goods which have been sealed in the container.

The functional object of my invention is to provide, in association with and for use in association with a destructible container, locking means which may be so applied to the body and lid of the container that the body and lid, when brought into assembled relation, are locked to each other so securely that destruction of the container is necessary in order that its contents may be removed.

A corollary object of my invention is to provide such an association of locking elements that they may be moved into position in which they do not cooperate to lock together the body and lid of the container, and which may be moved into such position that they do so cooperate in locking the lid of the container to the body of the container.

More specifically, the object of my invention is to provide an assembly of locking elements, and a container equipped with such locking assembly to fulfill the objects immediately above set forth, which locking elements are so formed and composed that the desired result is obtained by locking structures which are particularly inexpensive, so that the addition of the locking means to a container does not add substantially to the price of the container alone, and which locking means are peculiarly efficient in performing their intended function.

In the accompanying drawing, Fig. I is a view, partially in side elevation, and partially in vertical longitudinal section, showing a container equipped with my specialized locking means in closed condition, with the lid applied to, and locked to, the body of the container.

Fig. II is a fragmentary view showing one end of the container partially in side elevation and partially in vertical longitudinal section, showing the lid positioned on the body of the container, and illustrating the position of the locking means for permitting the lid to be applied to the body of the container, without being locked thereto.

Fig. III is a fragmentary view, taken in vertical longitudinal section, and showing one end of the container with the locking elements in position to automatically engage the lid to the body of the container, and illustrating the alignment of the locking elements prior to interengagement therebetween resulting from a completed positioning of the container lid on its body.

Fig. IV is a plan view of the blank from which the staple element of my locking assembly is formed.

Fig. V is a side elevation of the staple element, showing it in position for mounting on the wall of a container and in the inoperative condition shown in Fig. II of the drawing.

Fig. VI is a plan view of the staple element as shown in Fig. V.

Fig. VII is a plan view of the blank from which the hasp member of my locking assembly is formed.

Fig. VIII is a side elevation of the hasp member, showing it in condition for application to the lid of a container.

Fig. IX is a plan view of the hasp member as shown in Fig. VIII.

In the drawings, reference numeral 1 designates the bottom of a container body, and reference numeral 2 designates two opposed upstanding walls of the container. The container is, as shown, provided with a lid having an upper wall 3 and depending side walls 4, which embrace the walls 2 of the container body. It is to be understood that the container, considered as a whole, is of some suitable, readily destructible material, such as paste board, fibre board, or some other material which may be easily cut or torn.

Each locking assembly associated with the container comprises a staple element designated generally by reference numeral 5, and a hasp element designated generally by reference numeral 6. These locking elements are so arranged that when the staple is in locking condition the hasp engages with it automatically, by mere application of the container lid to the container body in the manner shown in Fig. I of the drawing.

As shown in the drawing, the container is of a rectangular contour, and is of relatively extended area with respect to its height. It is, therefore, shown with two locking assemblies spaced from each other a substantial distance in the container, so that the lid may be secured to the body of the container at separated points, and opportunity to disengage the container body and lid by manipulation is not afforded. It should be understood, however, that, as applied, for example, to a container of relatively small cross-sectional area, with respect to the depth of its lid, or a container having a hinged lid, a single locking assembly may be adequate to prevent access to the interior of the container.

Referring particularly to Figs. IV, V, and VI of the drawing, the staple 5 is made of a single blank

of suitable material, which may be stamped or punched to the desired form. For reasons which will hereinafter appear, the staple element of the locking assembly is desirably made of a metal which is flexible and deformable, but which possesses some degree of resilience. I have found light-gauge sheet copper, or light-gauge rustless iron, tin, and aluminum to be suitable materials for the purpose.

In the form of its blank, staple element 5 comprises a base portion 7 and an outer portion, or staple proper, 8. It will be seen in Fig. IV of the drawing that outer portion 8 inclines away from base portion 7, to a terminal edge of substantially greater width than that of the base portion 7. Outer portion 8 of the staple blank is punched to provide a slot 9, and the base portion 7 of the staple blank has therein intersecting cuts 10.

Referring to Fig. V of the drawing, which shows the staple as it is finally formed for mounting in a container, the material of the blank is flexed along the line of junction between the base portion 7 and outer portion 8, so that the outer or locking portion proper extends substantially at right angles to the base portion. The flaring regions of outer staple portion 8, which extend from the junction between the two portions of the staple to the terminal edge of outer portion 8, are up-turned in the die to provide side walls 11, which increase progressively in height from the junction line, or line of fold, between the two staple portions to the terminal edge of the outer staple portion 8. Two of the triangular pieces of material at the intersecting cuts 10 are turned outwardly from the body of base portion 7 to provide pointed fastening tangs 12.

In the form described, the staple is attached to wall 2 of the container by forcing the tangs 12 through the wall from the inner face thereof, and flexing them back to lie parallel to and against the outer surface of the wall. The staple is then in the position shown in Fig. II of the drawing.

Fig. VII of the drawing shows the blank from which hasp 6 is formed. The side edges of this blank desirably incline slightly from a terminal edge of greatest width, and in the region of greatest width the blank is provided with intersecting cuts 13. As formed, the blank is flexed in two directions to provide a base 14, which has thereon pointed tangs 15, formed by material freed by the intersecting cuts 13, a leg 16 extending substantially at right angles to the plane of the base 14, and a foot 17 which extends at a substantial angle to the plane of the leg 16.

The hasp in its completed form shown in Figs. VIII and IX is mounted on the inner surface of the upper lid wall 3, by forcing tangs 15 through the wall 3 from its inner surface, and clinching them over against the outer surface of the lid wall. In this mounted position, the hasp 6 has its leg 16 extending parallel to and closely adjacent the base portion 7 of the staple, with the foot 17 of the hasp extending outwardly into the container body, away from the base of the staple. This is seen clearly in Figs. II and III of the drawing, Fig. II showing the relative condition and position of the staple and hasp of the locking assembly when the lid is applied to the body of the container, with the locking elements in their inoperative condition.

This assembled, but unlocked, condition of the container is one suitable for shipment and handling when the container is empty, so that

the containers may conveniently be packed, and may be delivered in assembled, but unlocked, condition at the locality in which the contents of the containers are to be received. Simple preparation of the staple element, to place it in locking condition, is effected prior to the insertion of contents into the body of the container.

In order to place the staple 5 in locking condition, it is flexed as mounted in the container 10 on the line of junction between its base portion 7 and outer portion 8, so that outer portion 8 is brought into a position approximating parallelism with the base portion. It is, however, desirable that the two portions of the staple should not lie wholly parallel to each other throughout their vertical extent, so that the hasp may be inserted into and engaged in the socket formed by the staple.

This flexion is to such degree that the elastic limit of the metal is exceeded, and the staple portions therefore tend to remain in, and return to, this position. It will be seen in Figs. I and III of the drawings that, when the outer staple portion is brought into upstanding position, it inclines away from the body portion a progressively increased degree from the line of junction therewith to the plane of the upper terminal of the outer staple portion. This inclination, which provided an upwardly flared socket, is defined by the side walls 11 on the outer staple portion 8.

With the staples so mounted, and the desired contents inserted in the body of the receptacle, the lid of the container is applied and is locked to the container by engagement between the hasp 6 and staple 5. Fig. III illustrates the application of the lid to the body of the container with the hasp in alignment with the staple. As the lid is forced further over the container, from the position shown in Fig. I of the drawing, foot 17 of the hasp enters the flared upper region of the socket provided by the staple, and, being forced downwardly therein, flexes the outer staple portion 8 outwardly, so that the foot may pass downwardly in the socket as far as slot 9 in the outer staple portion. When foot 17 of the hasp is aligned with the slot 9, it snaps through this slot, thereby interengaging the hasp and staple.

It should be understood that it is unnecessary that hasp 6 be formed of resilient material, and is in fact desirable that it should not possess a high degree of resiliency. This is for the reason that the foot 17 of the hasp should possess sufficient rigidity that it may be capable of deflecting the outer portion of the staple. It is thus possible to make the hasp of a material different from that used for the staple, aluminum of gauge heavier than that used for the staple being an example of a material suitable for the purpose. It would also be possible to form base 7 of the staple of a material having greater rigidity than the outer portion 8 of the staple, were it not for the economy attendant upon forming the staple from a single integral blank.

It is not essential that the side walls 11 be provided along the side edges of the outer staple portion. These walls are convenient in bringing the staple into operative condition, since they serve to define the shape of the hasp-receiving socket. In their absence, however, the exercise of suitable care in forcing the outer staple portion into socket-forming, or operative,

position will serve to provide a socket suitably apportioned to the width of the foot 17 of the hasp, to give the desired snap effect in engaging the foot in slot 9.

5 It will be observed that in the closed and locked condition of the container, as shown in Fig. I of the drawing, the depending walls 4 of the lid lie outwardly of the mounting elements by which the staple is attached to the body of the container. It is, therefore, impossible to obtain access to these elements for detaching the staple, without destroying the lid of the container. Although the fangs, or other suitable fastening elements, by which the hasp is mounted on the upper wall of the lid, are accessible at the outer surface of this outer lid wall, that surface is normally covered by a label, or other ornamental covering of paper 18 or the like the destruction of which would indicate that tampering has taken place. It will be readily understood that, with the foot 17 lying in slot 9, the hasp may be displaced neither upwardly, downwardly, nor transversely, because of the confinement of the foot by the walls of the slot. If the fastening assemblies be applied in number and position adequate to the size and form of the container, turning movement of the container lid sufficient to free the hasp cannot be effected.

30 While various devices have been made or proposed for automatically locking a container lid to a container body, such devices have been of a structure which is much more expensive than the locking assembly herein described. While automatic container locks have been proposed for the safe delivery of jewelry, bonds, and other relatively valuable contents, the simplicity and inexpensiveness of my locking structure permits the widespread use of an automatically-locked, destructible container for materials which are of a lesser value, but which it is desired to deliver into the hands of the purchaser undisturbed. Thus a destructible container as herein disclosed is eminently suitable for packaging alcoholic liquors, olive oil, perfumes, cigars, and similar materials which are of moderate value, but the authenticity of which it is desirable to assure. In this connection, attention is called to the simplicity of the die-forming operation, in which both the staple and hasp elements may be produced, and the relatively small amount of metal, or other suitable material, going into their composition.

55 I claim as my invention:

1. The combination of a readily destructible container comprising a body and a lid, with means for automatically locking the lid to the body comprising at least one locking assembly for interengaging the lid and body; the locking assembly comprising a staple and a hasp, the staple consisting of a base portion for attachment to a wall of the container body to lie therein and an outer portion integral with the base portion and having side walls of progressively diminishing width from the terminal edge of the said outer portion to the line of junction with the base portion of the staple, said staple being deformable and flexible so that by flexion the outer staple portion may be swung outwardly to form a relatively great angle with the base portion of the staple and may by flexion be forced inwardly to form with the base portion a relatively slight angle approximately determined by the inclination in the side walls of

said outer portion, a slot in said outer staple portion intermediate its length, the hasp being arranged for attachment to the container lid and having a leg formed to extend downwardly and outwardly into the container body, the outward extension of the leg having a width no greater than that of the upper terminal of the socket formed by the two portions of the staple and greater than the width of the socket in the plane of said slot, whereby in aligned mounting of the locking elements on the body and lid of the container respectively the hasp carried by the lid may enter the staple socket by downward movement of the lid and by deflexion of the outer socket portion during downward movement may reach and project through the slot therein.

2. The combination of a readily destructible container comprising a body and a lid, with means for automatically locking the lid to the body comprising at least one locking assembly for interengaging the lid to the body; the locking assembly consisting of a staple and hasp, the staple having a base portion for attachment to a wall of the container body to lie therewithin and an outer portion integral with the base portion, said staple being deformable and flexible so that by flexion the outer portion may be swung outwardly to form a relatively great angle with the base portion and may by flexion be brought inwardly to form with the base portion a relatively slight angle and in cooperation therewith to provide an upwardly flaring socket, a slot in the outer staple portion intermediate its height, the hasp being arranged for attachment to the container lid and having a leg formed to extend downwardly and outwardly into the container body, said outward extension of the leg having substantial width, whereby in appropriate angular positioning of the outer portion of the staple the outwardly extending leg portion of the hasp may by deflexion of the outer staple portion be forced into the socket formed by the staple and into alignment with the slot in the staple to extend therethrough.

3. An automatically latching lock comprising in combination a staple and hasp; the staple consisting primarily of a flexible plate flexed along a line intermediate the ends of the plate into portions divergent from the line of flexion, a slot intermediately positioned in one of said portions, said staple portions being selectively flexible to form a socket by divergence of slight degree and by divergence of greater degree to form with each other an angle greater than that capable of forming a socket between the staple portions; the hasp consisting of a base portion, a leg carried by the base portion and having thereon a foot outstanding from the plane of the leg; whereby in aligned mounting on members to be interconnected the leg of the hasp may enter a socket formed by slight divergence of the staple portions and engage the foot thereon in the slot in one of said portions, or in greater divergence of the staple portions may lie between the said portions without locking engagement therewith.

4. An automatically latching lock comprising in combination a deformable female element formed as a socket flaring upwardly to an open end and having a wall thereof slotted intermediate its height, and a male element comprising a base and leg with a foot outstanding from the plane of the leg a distance greater than the width of the socket in its transverse plane at the intermediate slot therein; whereby in aligned

mounting of the male and female lock elements on members to be interconnected the leg of the male element may enter the socket and by deformation thereof engage in the slot of said
5 socket wall.

5. An automatically latching lock comprising a female element and a male element adapted for relatively aligned mounting on members to be interconnected, said female element being flex-
10 ible and capable of flexion into either operative

or inoperative conformation as mounted in alignment with the male element of the lock, said female element comprising a wall which in inoperative position forms a greater interior angle with a base plane than in operative position, and
5 said male and female element comprising interengaging means effective to lock the elements to each other in operative conformation of the female element.

FREDERICK H. GROVES. 10