

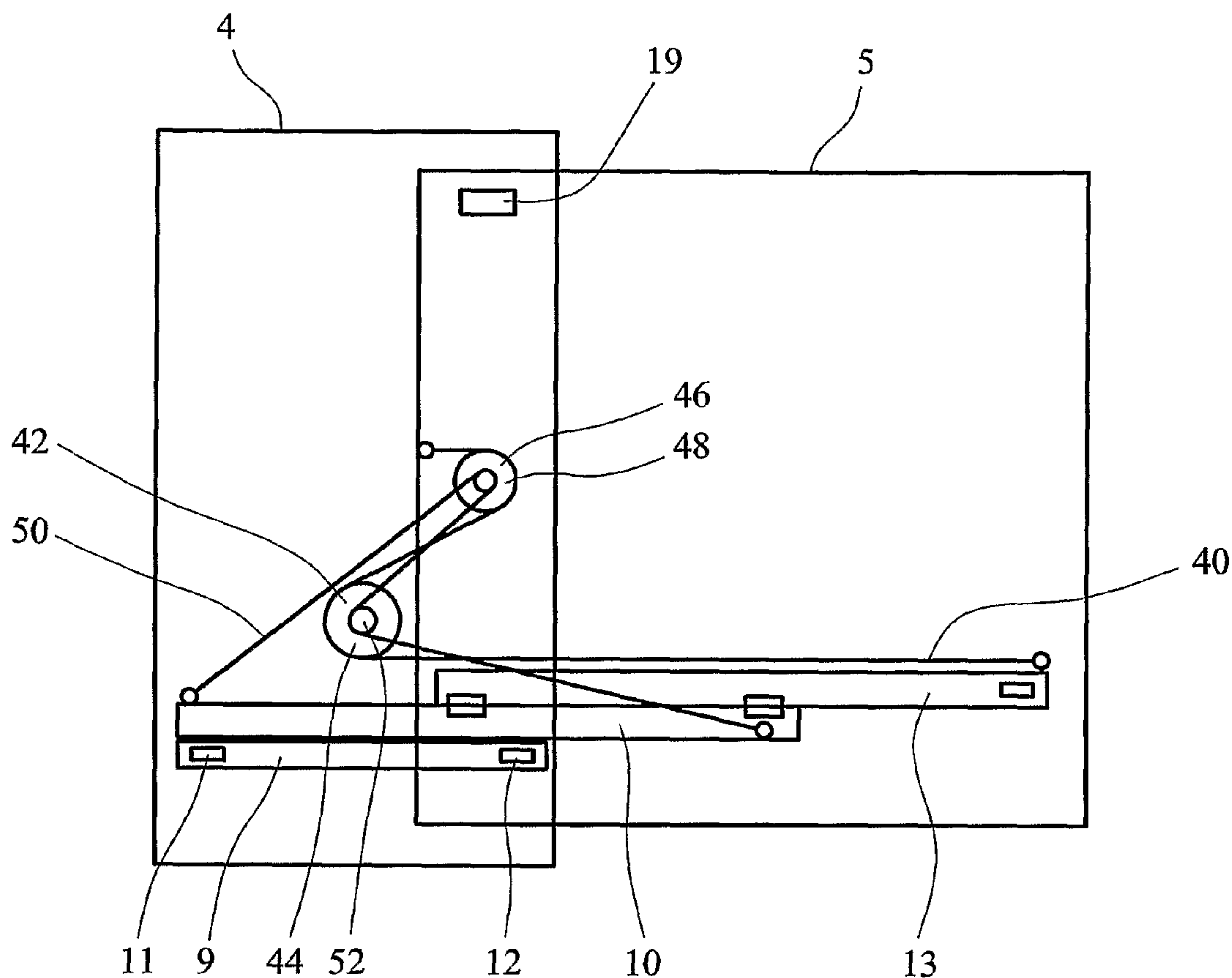

(86) Date de dépôt PCT/PCT Filing Date: 2006/03/15
 (87) Date publication PCT/PCT Publication Date: 2007/09/20
 (85) Entrée phase nationale/National Entry: 2008/09/10
 (86) N° demande PCT/PCT Application No.: GB 2006/000921
 (87) N° publication PCT/PCT Publication No.: 2007/104902

(51) Cl.Int./Int.Cl. *E05D 15/06* (2006.01),
B61B 1/02 (2006.01), *E05F 15/14* (2006.01)
 (71) Demandeur/Applicant:
KNORR-BREMSE RAIL SYSTEMS (UK) LIMITED, GB
 (72) Inventeur/Inventor:
HEMMINGS, MARK, GB
 (74) Agent: SMART & BIGGAR

(54) Titre : SYSTEME DE PORTE-ECRAN POUR QUAIS
 (54) Title: PLATFORM SCREEN DOOR SYSTEM



(57) Abrégé/Abstract:

A platform screen door system comprising a fixed driving panel (4) and at least one door leaf (5) slidable relative to the fixed driving panel (4). A belt drive system is adapted to slidingly move the door leaf from a door closed position to a door open position in which

(57) **Abrégé(suite)/Abstract(continued):**

the leaf lies overlapping with the fixed panel. The door system is provided with a telescopic guide (6), which guide comprises a fixed guide (9) mounted on the fixed driving panel, a moving guide (13) mounted on the door leaf and an intermediate moving guide (10) supported on the fixed guide (9).

(12) INTERNATIONAL APPLICATION PUBLISHED UNDER THE PATENT COOPERATION TREATY (PCT)

(19) World Intellectual Property Organization
International Bureau(43) International Publication Date
20 September 2007 (20.09.2007)

PCT

(10) International Publication Number
WO 2007/104902 A1

(51) International Patent Classification:

E05D 15/06 (2006.01) *B61B 1/02* (2006.01)
E05F 15/14 (2006.01)

(21) International Application Number:

PCT/GB2006/000921

(22) International Filing Date: 15 March 2006 (15.03.2006)

(25) Filing Language: English

(26) Publication Language: English

(71) Applicant (for all designated States except US): **KNORR-BREMSE RAIL SYSTEMS (UK) LIMITED** [GB/GB];
Westinghouse Way, Hampton Park East, Melksham, Wiltshire SN12 6TL (GB).

(72) Inventor; and

(75) Inventor/Applicant (for US only): **HEMMINGS, Mark** [GB/GB]; Westinghouse Way, Hampton Park East, Melksham, Wiltshire SN12 6TL (GB).

(74) Agent: **JENSEN & SON**; 366-368 Old Street, London EC1V 9LT (GB).

(81) Designated States (unless otherwise indicated, for every kind of national protection available): AE, AG, AL, AM,

AT, AU, AZ, BA, BB, BG, BR, BW, BY, BZ, CA, CH, CN, CO, CR, CU, CZ, DE, DK, DM, DZ, EC, EE, EG, ES, FI, GB, GD, GE, GH, GM, HR, HU, ID, IL, IN, IS, JP, KE, KG, KM, KN, KP, KR, KZ, LC, LK, LR, LS, LT, LU, LV, LY, MA, MD, MG, MK, MN, MW, MX, MZ, NA, NG, NI, NO, NZ, OM, PG, PH, PL, PT, RO, RU, SC, SD, SE, SG, SK, SL, SM, SY, TJ, TM, TN, TR, TT, TZ, UA, UG, US, UZ, VC, VN, YU, ZA, ZM, ZW.

(84) Designated States (unless otherwise indicated, for every kind of regional protection available): ARIPO (BW, GH, GM, KE, LS, MW, MZ, NA, SD, SL, SZ, TZ, UG, ZM, ZW), Eurasian (AM, AZ, BY, KG, KZ, MD, RU, TJ, TM), European (AT, BE, BG, CH, CY, CZ, DE, DK, EE, ES, FI, FR, GB, GR, HU, IE, IS, IT, LT, LU, LV, MC, NL, PL, PT, RO, SE, SI, SK, TR), OAPI (BF, BJ, CF, CG, CI, CM, GA, GN, GQ, GW, ML, MR, NE, SN, TD, TG).

Declaration under Rule 4.17:

— as to applicant's entitlement to apply for and be granted a patent (Rule 4.17(ii))

Published:

— with international search report

For two-letter codes and other abbreviations, refer to the "Guidance Notes on Codes and Abbreviations" appearing at the beginning of each regular issue of the PCT Gazette.

(54) Title: PLATFORM SCREEN DOOR SYSTEM

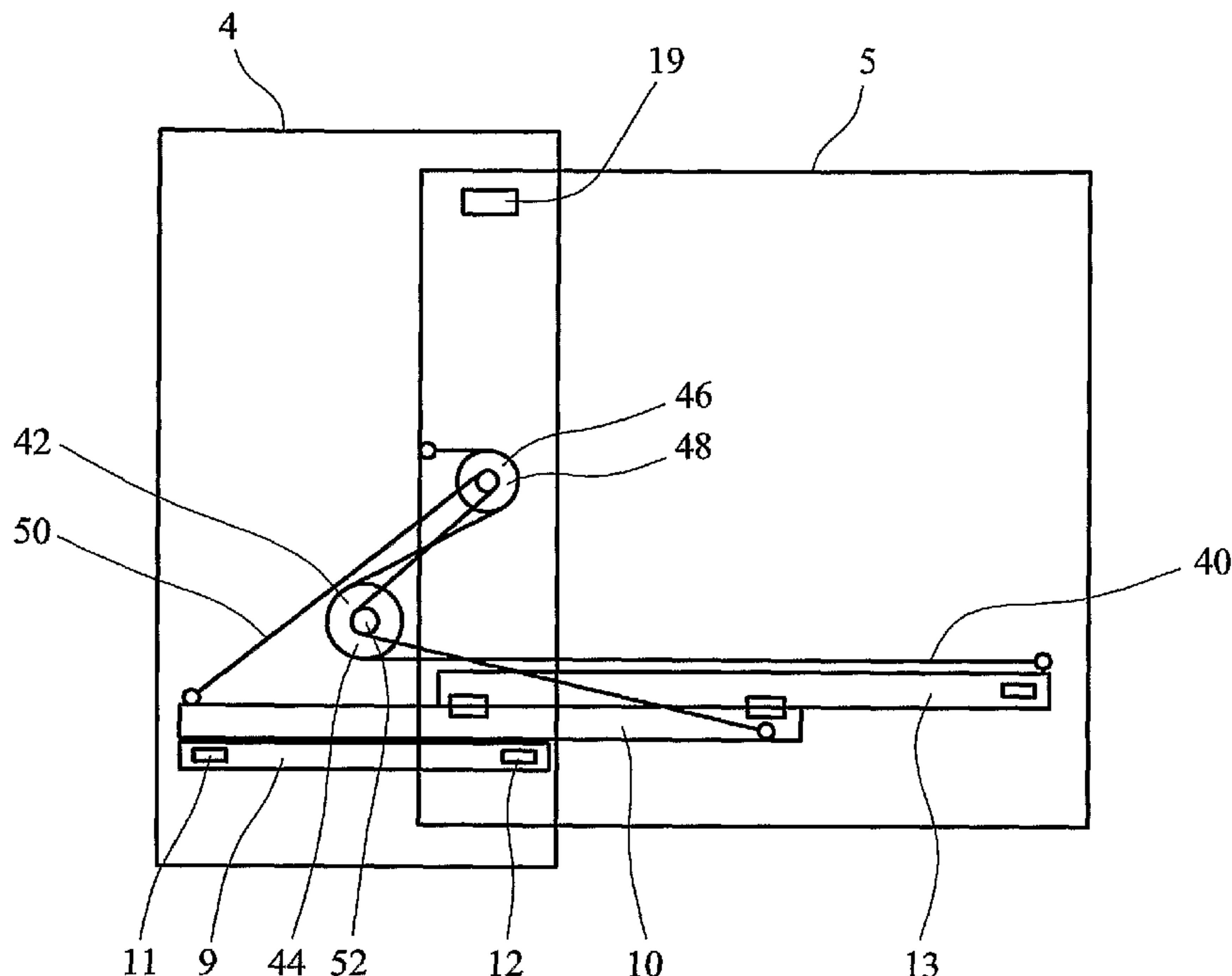

(57) Abstract: A platform screen door system comprising a fixed driving panel (4) and at least one door leaf (5) slidable relative to the fixed driving panel (4). A belt drive system is adapted to slidingly move the door leaf from a door closed position to a door open position in which the leaf lies overlapping with the fixed panel. The door system is provided with a telescopic guide (6), which guide comprises a fixed guide (9) mounted on the fixed driving panel, a moving guide (13) mounted on the door leaf and an intermediate moving guide (10) supported on the fixed guide (9).

WO 2007/104902 A1

Platform Screen Door System

The invention relates to a platform screen door or gate and a mechanism for opening and closing said door or gate.

The conventional railway station consisting of a raised platform adjacent to the track is essentially the same design as has been used since the beginning of the railway industry in the nineteenth century and is an effective solution to the problem of maximising passenger boarding speed.

However, the basic platform arrangement suffers from several well known problems, such as passengers falling under trains either deliberately or unintentionally and also litter from passengers falling onto the track. Although incidents of people falling under trains are not common, they result in significant disruption to the network and are traumatic incidents for everyone present. The problem of litter on the track has also increased in recent years and can represent a serious health and safety risk on underground or sub-surface systems where the litter will remain in tunnels until it is cleared up.

Platform screen systems or automated platform gates are well known in the railway industry as one approach of dealing with these problems. Due to the problem of lining up doors on the platform and the train, these systems are usually only installed on lines where the rolling stock is standardised, which in practice is on metro or underground systems, although some dedicated high speed systems are also provided with screens.

There are two main types of platform screen door system in use at present. The commonest type is a full height system (e.g. around 2m high or more vertical screens). The full height system is usually adopted for newly built railway systems and is in practice essential in air-conditioned systems as otherwise the air conditioning system loses air to the rail tunnels, which is highly inefficient.

However, in many systems, particularly older systems, the air in stations is conditioned by the passage of the train through the station, which forces air down the

tunnel. In such a system, the use of a full height screen door is precluded as the air throughput to the platform is insufficient to make conditions tolerable. Additionally, many platforms on old systems are quite narrow and a full height screen would be claustrophobic.

One solution to this that has been used is a half height screen or gate. This consists of a rigid vertical screen and gate, usually about 1m30 to 1m50 high, which permits the air-conditioning solution provided by the passage of the train to be used and reduces the problems caused by litter and people falling onto the track.

In full height systems, the screen doors are provided with a head structure, which houses an endless belt driven by a pulley at each end over each door. Where the opening comprises two door leaves, one leaf is attached to one part of the belt and the other leaf to the other part of the belt. Driving the belt in one direction will then open the doors.

The use of a head structure is obviously precluded in non full height systems and the known systems use the same approach but mounted into the platform surface. However, it is often difficult to retrofit such a system to a platform as it is expensive to dig channels out of the platform and the channel itself will accumulate dirt. Some solutions box in the mechanism but this approach suffers from the problem that the box stands proud of the platform forming a step which makes the system harder to use for wheelchair users.

A further problem is that on certain metro systems, the door pitch is quite short, which permits rapid embarkation and disembarkation of passengers but when this short pitch is allied with the required clearway when the door or gate is open leads to a requirement that the equipment to support and guide the sliding door in the closed position must not interfere with the sliding door or the area adjacent the door when the door is in the open position.. The problem is particularly acute in that the loads that the sliding doors must resist must be reacted over the length of support and the known head structures are generally not able to provide this due to space constraints.

The present invention therefore seeks to provide a platform screen gate and door which can operate with a shorter pitch.

According to the invention, there is provided a platform screen door system comprising a fixed driving panel and at least one door leaf slidable relative to the fixed driving panel, drive means adapted to slidably move the door leaf from a door closed position to a door open position in which the leaf lies overlapping with the fixed panel, the door system being provided with a telescopic guide, which guide comprises a fixed guide mounted on the fixed driving panel, a moving guide mounted on the door leaf and an intermediate moving guide supported on the fixed guide.

Preferably, the moving and intermediate guides are movable relative to the fixed screen on rollers. Preferably, the intermediate carries an abutment intermediate their length which, when the door is opened, contacts the moving guide to entrain the guide and move the moving guide relative to the fixed panel until the door is in the fully opened position. Preferably, wherein a belt drive is provided to drive the door leaf. Preferably, a second drive mechanism is provided comprising either a drive wire or motor is provided to drive the door leaf. In a preferred embodiment, a second drive mechanism is provided to drive the intermediate moving guide such that the intermediate moving guide is positively driven in a synchronised movement with the moving guide.

An exemplary embodiment of the platform screen door system of the invention will now be described in greater detail in which:

Fig. 1 shows a schematic of a platform screen door system

Fig. 2 shows a schematic of the guidance system for the doors

Fig. 3 shows a cross section of the guidance system

Fig. 4 shows an alternative embodiment including a belt drive

Fig. 5 shows a schematic of the door system in the open position.

Fig. 6 shows a roller arrangement.

Figure 1 shows a schematic of a platform screen door system with the sliding doors in the closed position on a railway platform comprising a first sliding door 1, adjacent to

a fixed driving panel 2, which fixed driving panel 2 is narrower than the sliding door 1. The fixed driving panel 2 is adjacent to a fixed panel 3 or the pivoting door, which in turn is adjacent to a further fixed driving panel 4, which is adjacent to a further sliding door 5. A guide 6 is provided at the lower edges of the fixed driving panels 2 and 4. A head structure 7 is provided on the upper edge of the fixed driving panels 2 and 3 and the fixed panel 3.

Figure 2 shows the fixed driving panel 4 and the sliding door 5 in the closed position with the guide 6. The guide 6 comprises a fixed guide 9 comprising two rollers 11, 12 mounted on the frame of the fixed driving panel 4. The guide 6 further comprises a moving door guide 13 and a moving intermediate door guide 10. The intermediate door guide 10 is supported on the rollers 11 and 12 and floats free of the panel 4 and the door 5. Further V channelled rollers 14,15 are mounted on the intermediate door guide 10. The moving door guide 13 is supported on the rollers 14,15 and is fixed to the door panel 5. At the upper edge of the fixed driving panel 4 and the sliding door 5 a pair of rollers 19,20 guide the door.

The fixed guide 9 is both adapted to support the moving guide 13 and the intermediate guide 10 and thereby the sliding door 5. To facilitate the support and guidance of the doors over a short distance the guide 6 is telescopic comprising two sections, the first defined by the rollers 11 and 12, respectively, which sections are fixedly mounted on the fixed position driving panel 4. The second section, which is adapted to slide telescopically within the first section as the door 5 opens is defined by the rollers 14,15. The telescopic nature of the guides and channels enables the loads applied to the sliding doors to be reacted over a greater length of support structure than would otherwise be the case with the knock-on effect that bearing loads are considerably reduced.

As the door is opened by the drive mechanism, the moving door guide 13 moves relative to both the intermediate guide 10 and the fixed guide 9 until an abutment engages on the intermediate guide 10. Continued movement moves both the moving door guide 13 and the intermediate guide 10 relative to the fixed panel 4 until the door has reached the controlled open position.

Figure 3 shows a cross-section view of the fixed driving panel 4 and sliding door 5 and shows the telescopic guide together with the respective rollers and moving guide, intermediate guide and the header arrangement 7. Located adjacent the guide 9 is the drive mechanism 30. The drive mechanism comprises a control unit adapted to actuate an electric motor, which motor drives a belt and pulley arrangement which pulls the door leaf in the appropriate direction to open and close the door.

Figure 4 shows schematically an embodiment in which the drive mechanism comprises a belt drive for the guide 6. The belt drive comprises a belt 40 which belt is attached at a first end to the free end of the sliding door panel 5 slightly above the height at which the guide 13 travels. The second end of the belt 40 is attached to the other end of the door via a driven pulley 44 mounted on the fixed driving panel and a further idler pulley 46 mounted on the door leaf. A further driven pulley 42 is rigidly mounted coaxially with the driven pulley 44. A further belt 50 is attached to both ends of the intermediate guide 10 via the third pulley 42 coaxially mounted with the pulley 44 and a fourth idler pulley 48 mounted co-axially with the pulley 46. A motor 52 is provided to drive the pulleys 42 and 44, thereby driving the guide and the sliding door. The third and fourth pulleys 42, 48 are half the size of the pulleys 44,46.

The use of the belt drive has the advantage that more even power is drawn from the motor, in particular at the point when the moving guide support 13 is moved clear of the intermediate guide 10 where current spikes could occur, which the control software might interpret as an obstruction.

Figure 5 shows schematically the door in the open position, showing that the door leaf 5 extends past the fixed driving panel 4. The telescopic guide members 9, 10 and 13 are shown in the open position. During the opening of the gate system, the loads caused by the motion of the door are reacted between the rollers 11 and 12, which reduces the loads on the bearings giving the system higher stability.

Figure 6 shows in greater detail the roller arrangement 19. Adjacent to the roller 19 are two resilient bearing surfaces 60,61 are provided, which bearing surfaces are substantially planar with rounded edges. The bearing surfaces 60,61 are provided to support the door leaf under side load conditions as it moves thereby removing some of

the forces acting on the respective roller to extend its life. Under some conditions a double roller arrangement may be used.

The telescopic mechanism of the invention is suitable for use in both full height platform screen doors and also half height automatic gates and the term screen door applies also to half height systems and gates. The present invention allows the installation and operation of a platform sliding door in situations where a short door pitch is provided on the trains which makes it extremely difficult using the existing technology to provide platform doors aligned with all the doors on a train.

In place of the roller arrangement, it would be possible to use a linear slide arrangement using for example low friction plastics or ball bearings.

It would also be possible to use a damping arrangement to damp the acceleration and deceleration of the intermediate guide and thereby avoid using a second belt drive. Alternatively, a linear motor could be used as the drive means.

Claims

1. A platform screen door system comprising a fixed driving panel and at least one door leaf slidable relative to the fixed driving panel, drive means adapted to slidably move the door leaf from a door closed position to a door open position in which the leaf lies overlapping with the fixed panel, the door system being provided with a telescopic guide, which guide comprises a fixed guide mounted on the fixed driving panel, a moving guide mounted on the door leaf and an intermediate moving guide supported on the fixed guide.
2. A platform screen door system according to Claim 1, wherein the moving and intermediate guides are movable relative to the fixed screen on rollers.
3. A platform screen door system according to Claim 3, wherein the intermediate carries an abutment intermediate their length which, when the door is opened, contacts the moving guide to entrain the guide and move the moving guide relative to the fixed panel until the door is in the fully opened position.
4. A platform screen door system according to any one of Claims 1 to 3, wherein a belt drive is provided to drive the door leaf.
5. A platform screen door system according to any one of Claims 1 to 4, wherein a second drive mechanism is provided comprising either a drive wire or motor is provided to drive the door leaf.
6. A platform screen door system according to any one of Claims 1 to 3, wherein a second drive mechanism is provided to drive the intermediate moving guide (10) such that the intermediate moving guide (10) is positively driven in a synchronised movement with the moving guide (13)

-1/3-

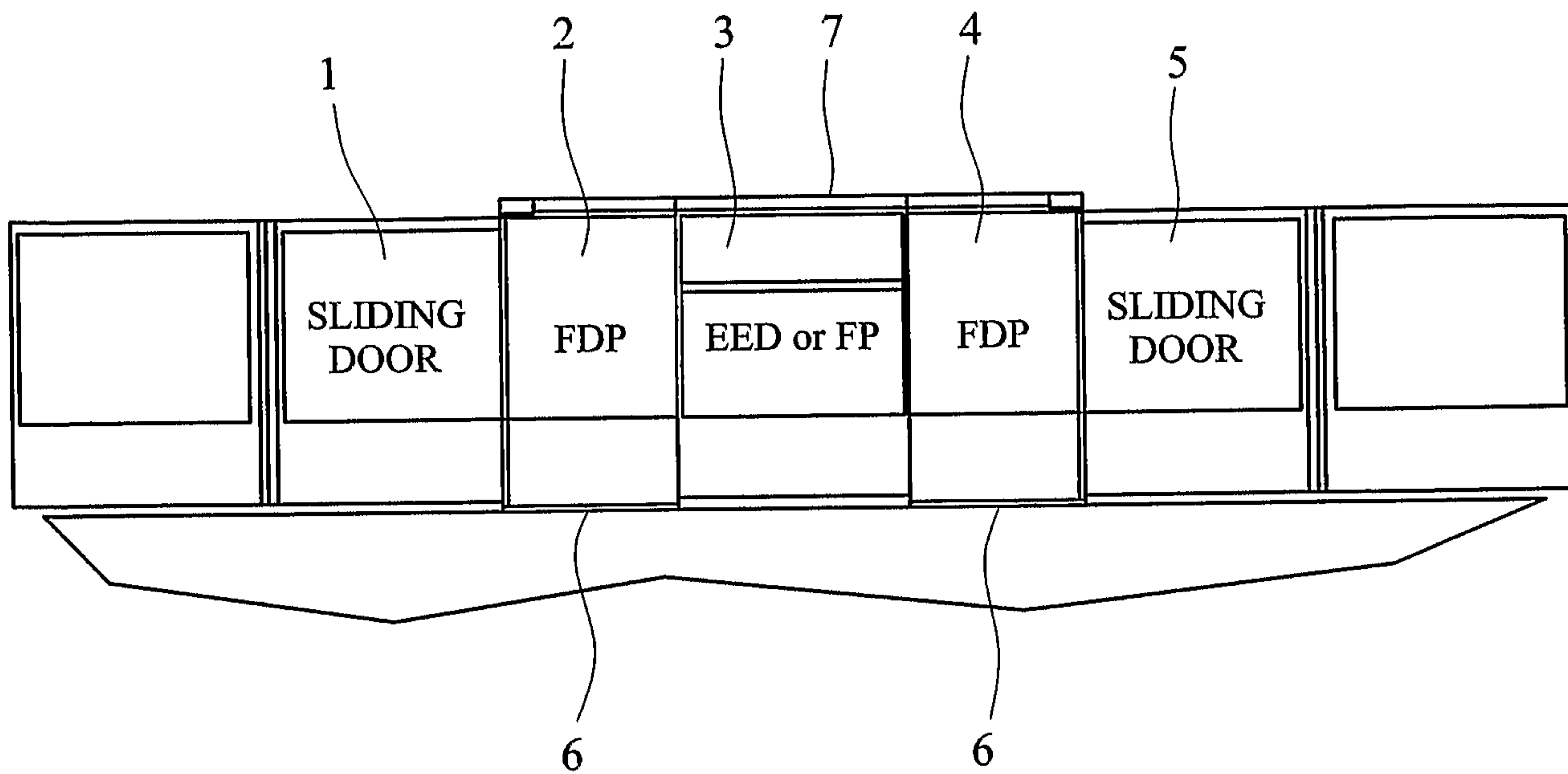

FIG. 1

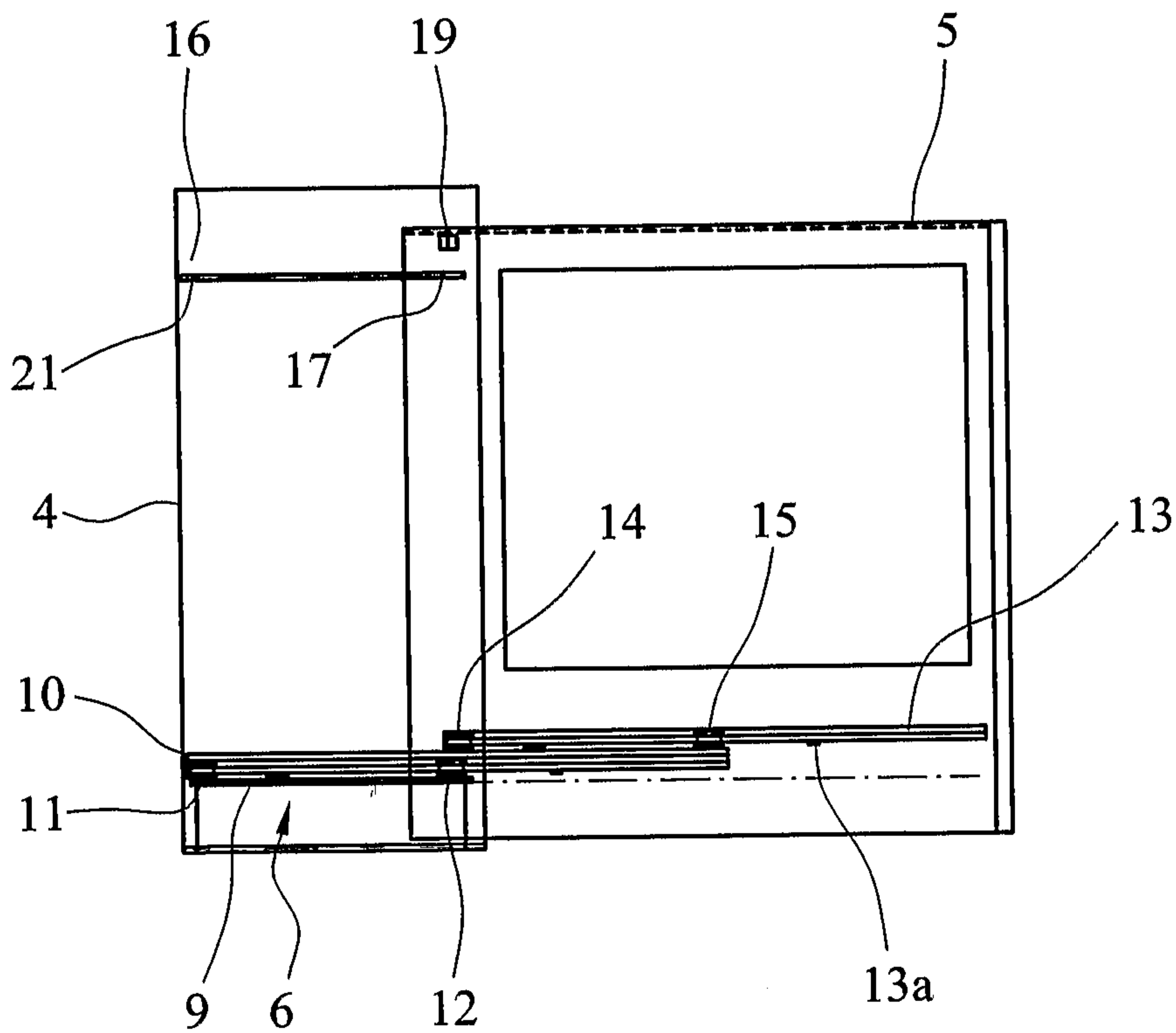

FIG. 2

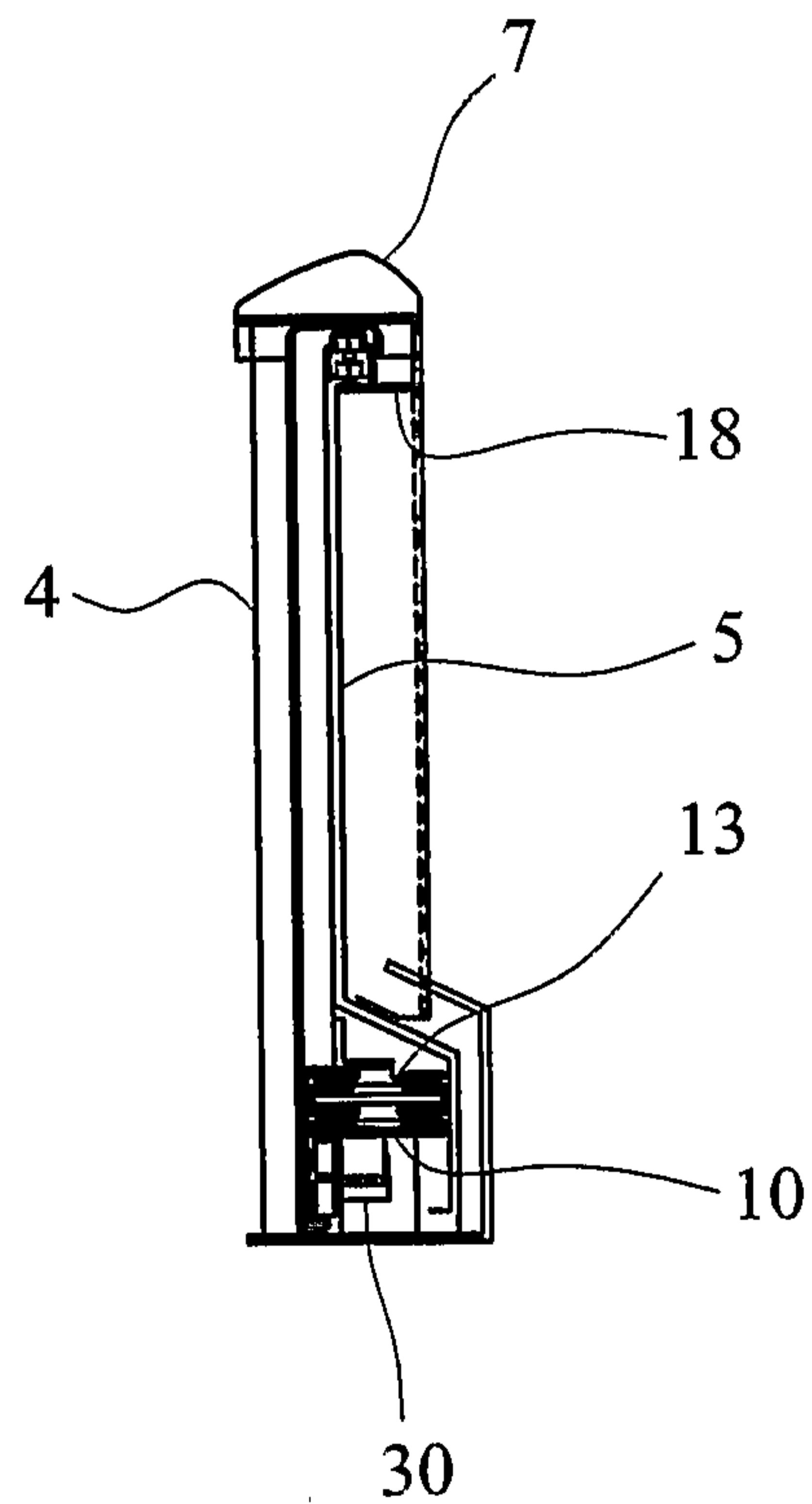

FIG. 3

-2/3-

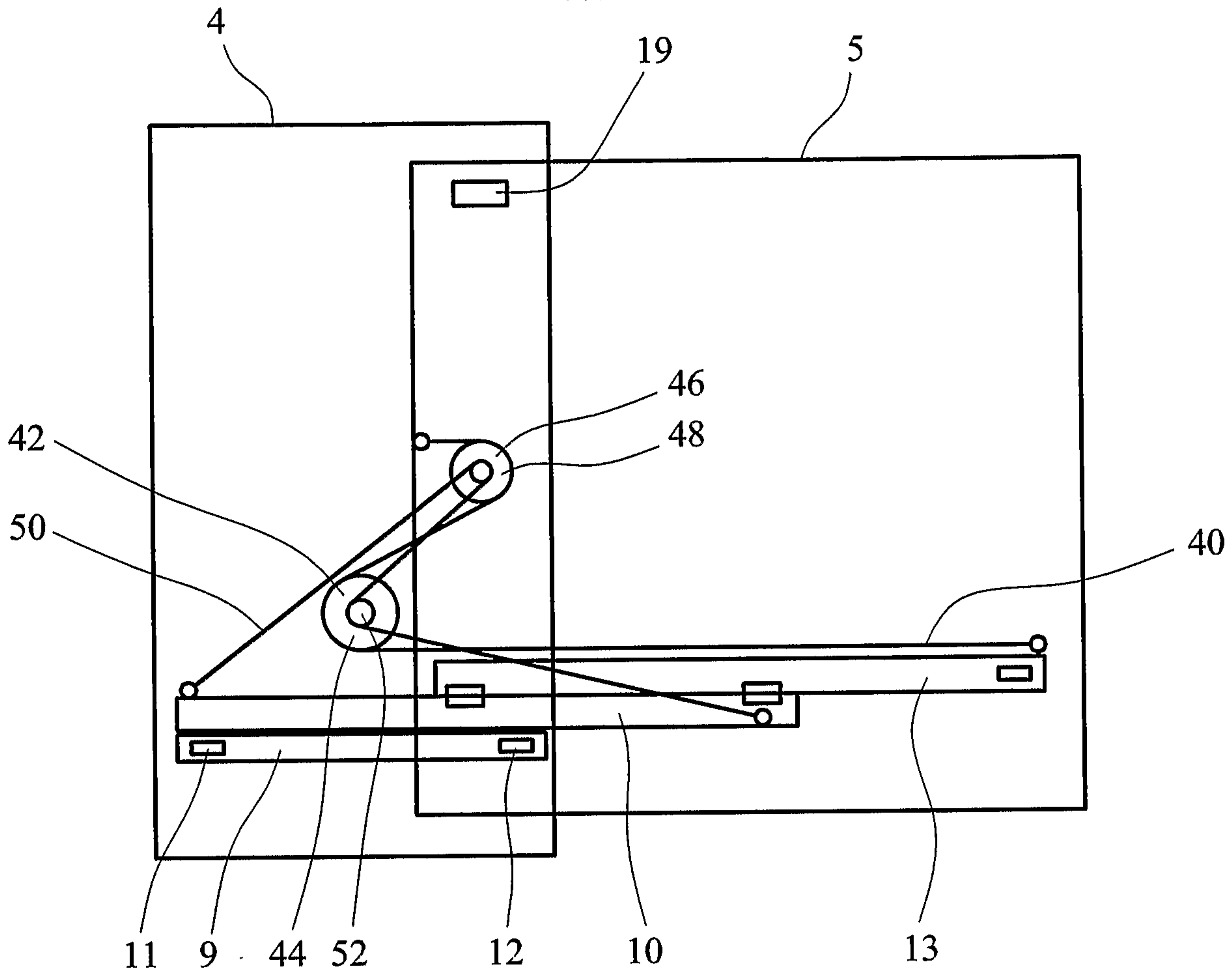

FIG. 4

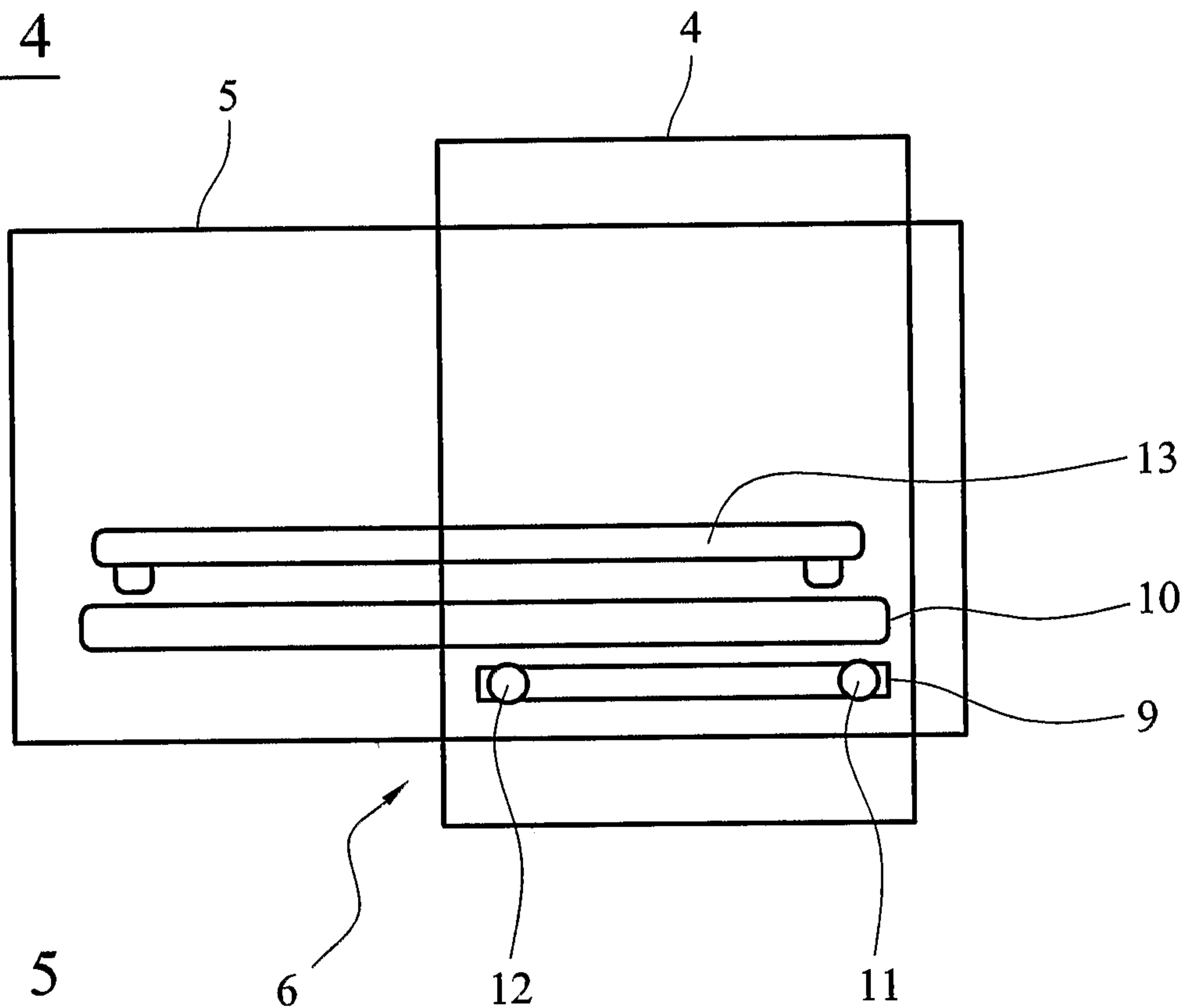

FIG. 5

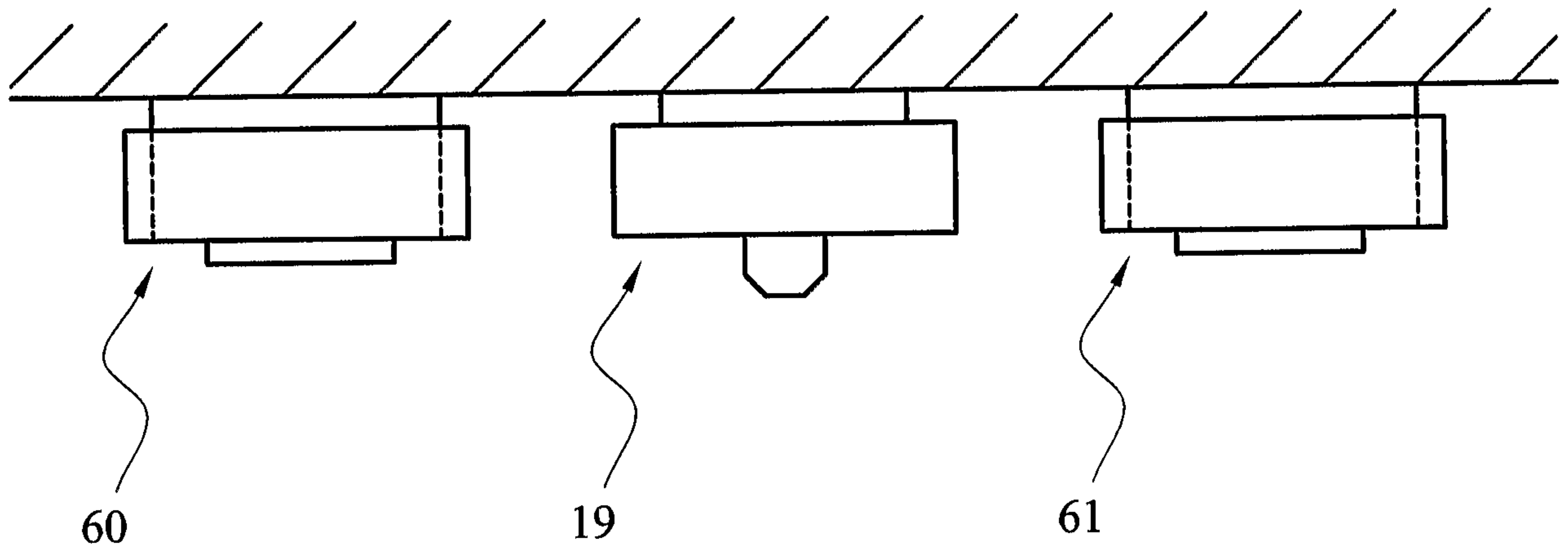

FIG. 6

