

(No Model.)

T. S. MILLER.
HOISTING AND CONVEYING APPARATUS.

No. 521,035.

Patented June 5, 1894.

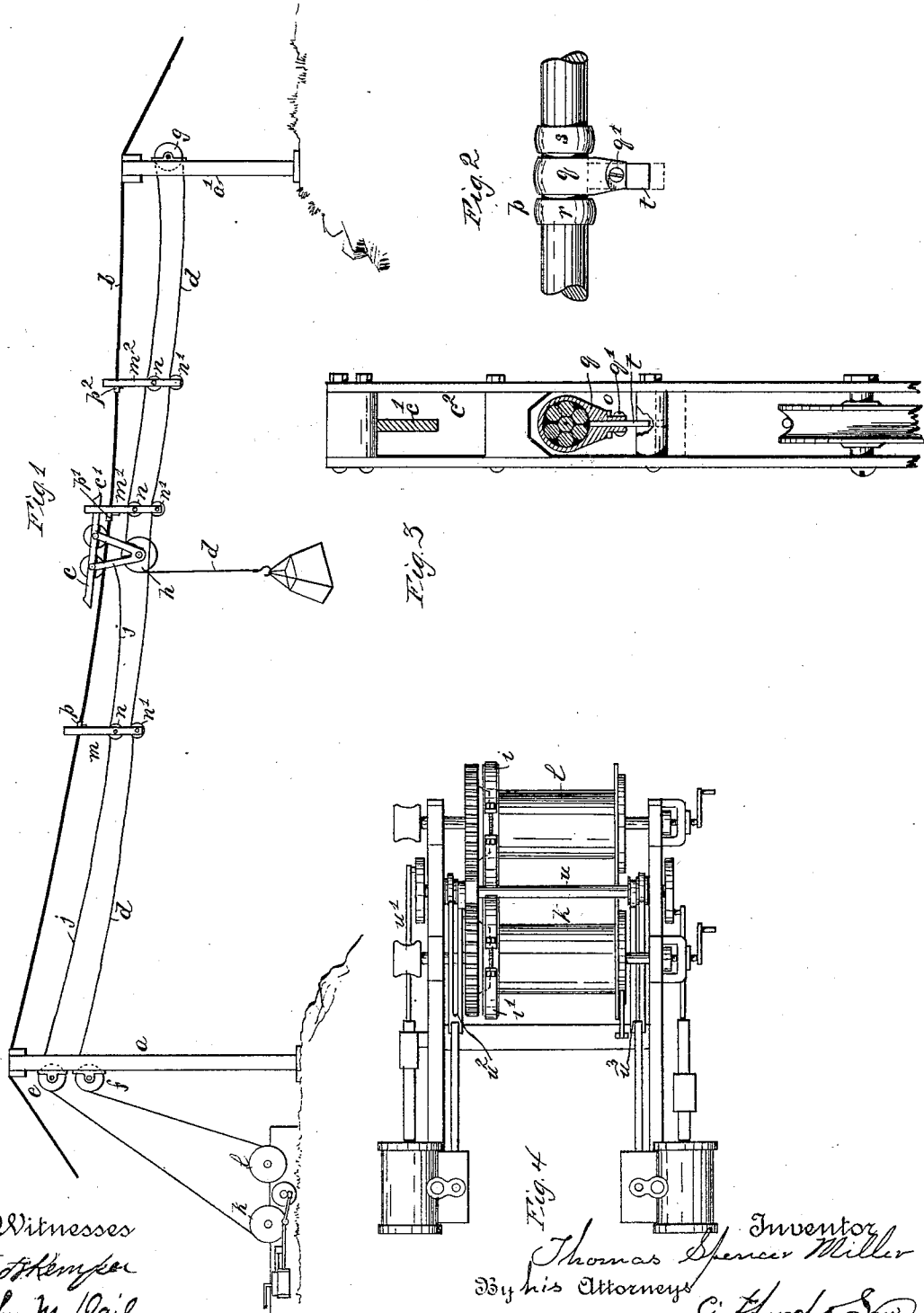

Witnesses
Fred Kempfer
John M. Daily

Inventor
Thomas Spencer Miller
By his Attorneys
Gifford & Saw

UNITED STATES PATENT OFFICE.

THOMAS SPENCER MILLER, OF SOUTH ORANGE, NEW JERSEY.

HOISTING AND CONVEYING APPARATUS.

SPECIFICATION forming part of Letters Patent No. 521,035, dated June 5, 1894.

Application filed July 12, 1892. Serial No. 439,756. (No model.)

To all whom it may concern:

Be it known that I, THOMAS SPENCER MILLER, of South Orange, in the State of New Jersey, have invented a new and useful Improvement in Hoisting and Conveying Apparatus, of which the following is a specification.

Figure 1 is a general side view of my apparatus. Fig. 2 is a detail showing a side view of the cable and one of the stops. Fig. 3 is a detail showing a cross section of the cable and an end elevation of a rope carrier and stop with variations in the length of the stop and of the carrier slot indicated in dotted lines; the lower boundary of the slot being broken away to show the full length, in full lines, of the stop plate. Fig. 4 is a plan view of a reversible link motion friction drum engine having two drums.

a a' are the two towers, the distant one a' of which is at a lower level than the other.

b is the cable or trackway.
 c is the load carriage.

d is the fall rope which extends from a friction hoisting drum l over the sheave f mounted on the tower a around the sheave g , mounted on the tower a' , over the sheave h on the carriage c and thence down to the load i .

j is the inward hauling rope which extends from the friction-drum k over the sheave e on the tower a to the carriage c to which its extremity is fastened. The shafts e' and h' upon which the drums e and k are loosely mounted are geared to the shaft u which is driven by connecting rod u' of the engine. The rotation of the shaft u may be reversed by the usual link motion $u^2 u^3$ of the well known construction. The ordinary foot brakes v and v' are provided for the drums. The ropes d and j are coiled on their drums inversely, as shown in Fig. 1. Thus, when the engine runs either way, one rope will pay out as the other is hauled in, but it is within the power of the operator to arrest the motion of either rope by unclutching its drum and applying its brake.

m , m' m^2 are rope carriers each supporting two carrier sheaves n and n' . The rope carriers are strung upon the cable b which occupies a slot o in each, the width of which very nearly corresponds with the diameter of the cable and the length of which, vertically, varies.

p , p' , and p^2 are stops fixed in position along the cable or trackway, though not necessarily mounted directly upon it, as shown, which act to distribute the rope carriers along the cable. Each of these stops consists of a clamp q loosely embracing the cable between two fixed collars r and s so as to remain perpendicular should the cable revolve. The radial projection of these three parts from the cable is reduced as much as possible so as not to interfere with the movements of the carriage, excepting that the clamp q projects radially downward and its extremities are secured together by the bolt q' . Between the extremities is clamped a vertical plate t , the length of which downward, varies for the different stops.

Now, it is the co-operation between the length of the slot o in the rope carrier and the length of the plate t in the stop which determines by which stop a given carrier shall be arrested. In Fig. 3 the plate t , in full lines, is long enough to project below the lower boundary of the slot o , in full lines, but not long enough to project below the lower boundary of the slot o , in dotted lines; but the plate t in dotted lines is long enough to project below the lower boundary of the slot o , in dotted lines. Therefore, if the plate t were only as long as indicated in full lines it would be passed by a rope carrier having a slot as long as indicated in dotted lines, but would arrest a carrier having a slot only as long as indicated in full lines; and a carrier having a slot as long as indicated in dotted lines would not be arrested until it reached a stop having a plate as long as that indicated in dotted lines. The series of plates t increase in length from tower a' toward tower a ; the series of slots o increase in length correspondingly. When therefore, the carriage c moves toward the tower a' it will pick the carriers up successively on its horn c' which enters slot c^2 in each and carry them as far as it goes in that direction. On its return toward tower a , the slot in the carrier m^2 being the shortest, will strike against the shortest plate t , being that on the stop p^2 . The slot in the carrier m' being longer will pass by the stop p^2 but will be arrested by the plate t on the stop p' and so on throughout the series; each rope carrier upon being arrested having its

support transferred from the horn *c'* to the cable or trackway. When the carriage *c* advances toward the tower *a* the same operation will be repeated upon the carrier *m*.

5 When the carriers rest at their respective stops on the cable or trackway, they will be properly spaced to support any ropes which they may be intended to carry. In this case, they are shown as supporting on one side of
10 the carriage both branches of the fall rope *d*, and on the opposite side of the carriage one branch of the fall rope *d* and also the inward hauling rope *j*.

In the arrangement shown, the fall rope may
15 perform the function of an outward hauling rope for the carriage as well as the function of hoisting the load. In the drawings, the cable or trackway is shown at an inclination downwardly toward the distant tower so that
20 the carriage will be run out toward the tower *a'* by its own weight. The cable being inclined renders unnecessary any gate or hooks to hold the carriage, for the inward hauling rope holds the carriage when the hoist rope
25 is slackened to lower the block.

The stop that I have above described is distinct from the stops shown in my former patents, Nos. 447,892 and 434,550, for illustrating the inventions therein described, in that the
30 stops in said former patents project above as well as below the ropes by which they are supported, which form of stop is disclaimed so far as this application is concerned.

I claim—

35 1. In a conveying apparatus in combination, a cable or trackway, a carriage, a rope

carrier and a stop connected with the cable or trackway and projecting substantially downwardly from the same, whereby auxiliary means of supporting the stop are dispensed
40 with without affording any impassable obstacle to the running of the wheels of the carriage on the cable or trackway, substantially as described.

2. In a conveying apparatus in combination, a cable or trackway, a carriage, a rope
45 carrier, a stop-plate parallel with the line of travel projecting downwardly into the line of travel of the rope carrier, and a member whereby said plate is secured to a fixed support
50 so as to project wholly on one side thereof, substantially as described.

3. In a conveying apparatus in combination a cable or trackway, a carriage, a rope
55 carrier, a clamp embracing the cable or trackway and a downwardly extending stop-plate secured between the extremities of said clamp parallel with the line of travel, substantially as described.

4. In a conveying apparatus in combination a cable or trackway, a carriage, a rope
60 carrier provided with a slotted opening to receive the cable or trackway and a stop projecting downwardly in only one direction beyond the boundary of said slotted opening
65 below the cable or trackway, substantially as described.

THOS. SPENCER MILLER.

Witnesses:

FRED S. KEMPER,
JAMES T. LAW.