



(12) **DEMANDE DE BREVET CANADIEN
CANADIAN PATENT APPLICATION**

(13) **A1**

(86) Date de dépôt PCT/PCT Filing Date: 2017/11/27
(87) Date publication PCT/PCT Publication Date: 2018/06/14
(85) Entrée phase nationale/National Entry: 2019/06/04
(86) N° demande PCT/PCT Application No.: EP 2017/080537
(87) N° publication PCT/PCT Publication No.: 2018/104094
(30) Priorité/Priority: 2016/12/07 (AT A 51118/2016)

(51) Cl.Int./Int.Cl. *E01F 15/08* (2006.01)
(71) Demandeur/Applicant:
KIRCHDORFER FERTIGTEILHOLDING GMBH, AT
(72) Inventeurs/Inventors:
EDL, THOMAS, AT;
SPITZER, FRANZ, AT
(74) Agent: MARKS & CLERK

(54) Titre : ELEMENT D'ARMATURE
(54) Title: REINFORCING ELEMENT

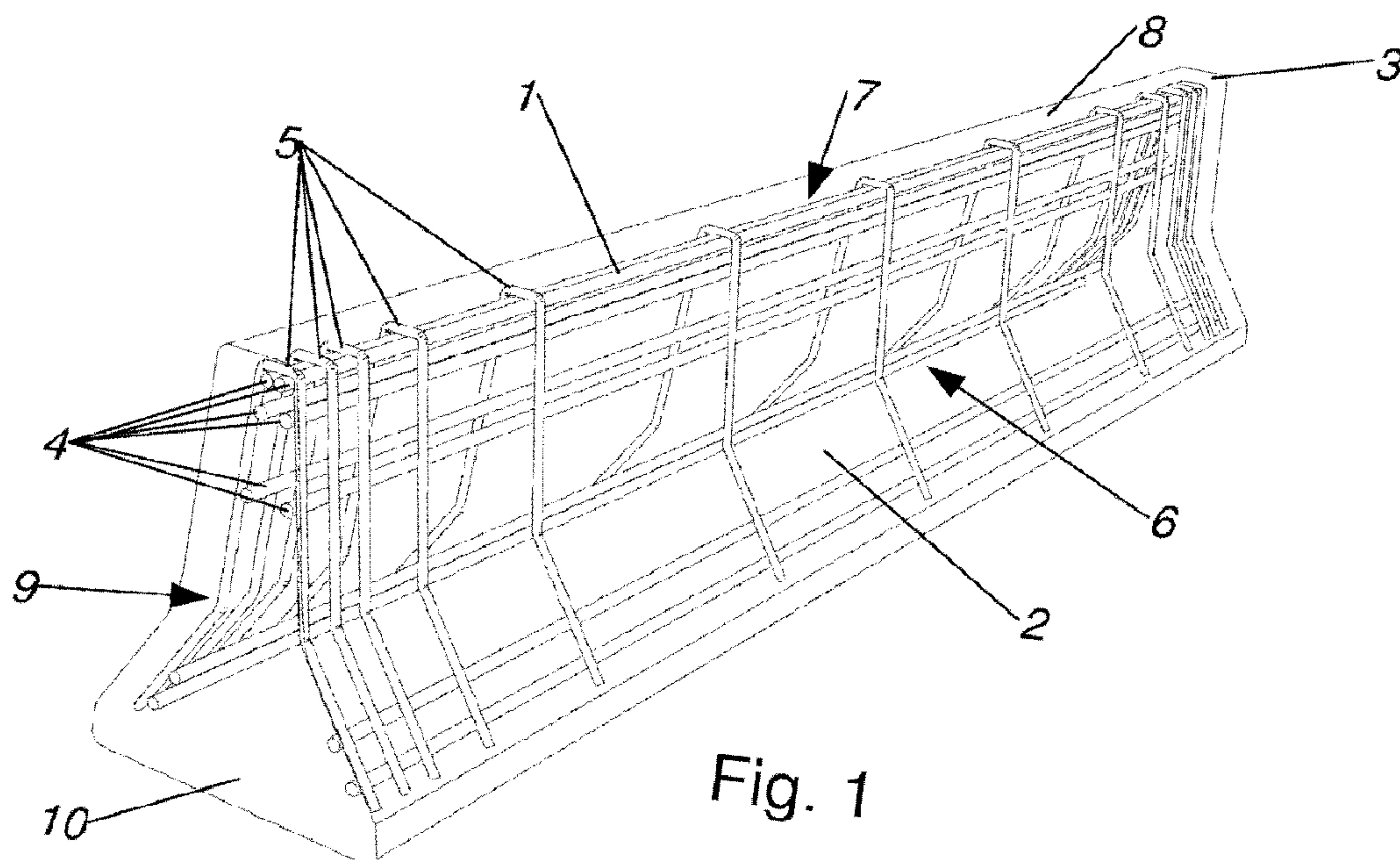

(57) Abrégé/Abstract:

The invention relates to a reinforcing element (1) for a concrete barrier-wall element (3), which concrete barrier-wall element has a repelling profile on at least one longitudinal side (2), wherein the reinforcing element (1) has longitudinal reinforcing bars (4) and has bows (5), which extend transversely to the longitudinal reinforcing bars (4) and are connected to the longitudinal reinforcing bars (4). According to the invention, the reinforcing element (1) has at least one first region (6) and the first region (6) largely has the repelling profile. The invention further relates to a method for producing a concrete barrier-wall element having a repelling profile on at least one longitudinal side (2).

WO 2018/104094 A1 

(84) Bestimmungsstaaten (soweit nicht anders angegeben, für jede verfügbare regionale Schutzrechtsart): ARIPO (BW, GH, GM, KE, LR, LS, MW, MZ, NA, RW, SD, SL, ST, SZ, TZ, UG, ZM, ZW), eurasisches (AM, AZ, BY, KG, KZ, RU, TJ, TM), europäisches (AL, AT, BE, BG, CH, CY, CZ, DE, DK, EE, ES, FI, FR, GB, GR, HR, HU, IE, IS, IT, LT, LU, LV, MC, MK, MT, NL, NO, PL, PT, RO, RS, SE, SI, SK, SM, TR), OAPI (BF, BJ, CF, CG, CI, CM, GA, GN, GQ, GW, KM, ML, MR, NE, SN, TD, TG).

Veröffentlicht:

— mit internationalem Recherchenbericht (Artikel 21 Absatz 3)

(1) zumindest einen ersten Bereich (6) aufweist, und dass der erste Bereich (6) im Wesentlichen das Abweiseprofil aufweist. Weiters wird ein Verfahren zur Herstellung eines, an wenigstens einer Längsseite (2) ein Abweiseprofil aufweisendes Betonleitwandelements vorgeschlagen.

Reinforcing element

The invention relates to a reinforcing element according to the preamble of claim 1.

Reinforcing elements of this type are used for concrete barrier-wall elements of a vehicle restraint system. Concrete barrier-wall elements are prefabricated concrete parts which together form a vehicle restraint system that is meant to prevent vehicles from exiting the roadway or crossing into the opposing lane. Concrete barrier-wall elements of this type have a characteristic profile on at least one longitudinal side facing the roadway, which ensures that a vehicle driving against it at an angle does not bounce off, but is deflected in a travelling direction parallel to the longitudinal side.

Concrete barrier-wall elements usually have a reinforcement, which is bound from a plurality of individual elements. In this case, the actual form of the reinforcement depends on the retaining effect of the concrete barrier-wall elements to be achieved, wherein on the other hand it is a goal to use as little reinforcing material as possible for economic reasons.

The reinforcement usually has at least longitudinal reinforcing bars, in order to reduce sagging or prevent the concrete barrier-wall element from breaking through in the event of an impact. The longitudinal reinforcing bars are frequently inserted centrally in this case. Moreover, the longitudinal reinforcing bars are often connected with bows, in order to increase the internal stability. In order to avoid spalling, especially in the head region of the concrete barrier-wall elements, additional filigree reinforcing steel mats are often used.

A concrete barrier-wall element with a bound or welded reinforcement basket is known from US 5 651 635 A. Thereby the bows are arranged completely circulating and bent in such a manner that they form the repelling profile.

A concrete barrier-wall element formed as prefabricated part is known from FR 2 862 674 A1. The reinforcement is achieved by connecting longitudinal bars connected by means of bows, wherein the profile of the reinforcement is formed by two L-shaped bows and one U-shaped bow.

A concrete barrier-wall element with a reinforcement with a U profile is known from EP 1 063 357 A1.

The disadvantage of this is that such reinforcements for concrete barrier-wall elements are very costly and labour-intensive in production. Moreover, variations in the retaining effect of the concrete barrier-wall elements occur due to the bound reinforcement, since errors or deviations in the binding of the individual reinforcement parts can arise, or individual reinforcement parts are shifted during the concrete casting process.

It is therefore an object of the invention to provide a reinforcing element of the type mentioned at the beginning with which the disadvantages mentioned can be avoided, with which a concrete barrier-wall element can be produced with less effort and thereby has a reliably high retaining effect while the process reliability in the production process is increased.

This is achieved according to the invention by the features of patent claim 1.

This provides the advantage that concrete barrier-wall elements can be produced with less effort but higher reliability. In this case, the longitudinal reinforcing bars and bows are already formed in such a way that they have the repelling profile of the concrete barrier-wall element to be produced, so that a very stable reinforcement can be positioned close to the relevant surfaces. As a result, there is no need for a complex construction with filigree reinforcing steel mats at exposed points. A further advantage is that the previous overlaps of the longitudinal reinforcing bars, bows and reinforcing steel mats is reduced to overlapping of the longitudinal reinforcing bars with the bows. Reinforcement layers are thus significantly reduced in these overlapping regions. Moreover, the reinforcing elements can already be prefabricated in large quantities and then delivered to the concrete plants, where the concrete barrier-wall elements are then cast. As a result, a significantly more economic production is possible, but also with narrower production tolerances.

The invention further relates to a concrete barrier-wall element according to patent claim 9.

2a

The invention further relates to a method for producing a concrete barrier-wall element having a repelling profile on at least one longitudinal side according to patent claim 13.

It is therefore further an object of the invention to provide a method with which the disadvantages mentioned can be avoided, with which a concrete barrier-wall element can be produced with less effort and thereby has a reliably high retaining effect.

This is achieved according to the invention by the features of patent claim 13.

AMENDED SHEET

The dependent claims relate to further advantageous embodiments of the invention.

Reference is hereby expressly made to the wording of the patent claims, whereby the claims are incorporated into the description by reference at this point and are deemed as rendered literally.

The invention is described in detail with reference to the enclosed drawings, in which only preferred embodiments are shown by way of example. Thereby,

Fig. 1 shows a concrete barrier-wall element with a first preferred embodiment of the reinforcing elements in an axonometric representation;

Fig. 2 shows a concrete barrier-wall element with a second preferred embodiment of the reinforcing elements in an axonometric representation;

Fig. 3 shows a detail of Fig. 2;

Fig. 4 shows the concrete barrier-wall element of Fig. 2 as an exploded view; and

Fig. 5 shows a stack of reinforcing elements of the second preferred embodiment in an axonometric representation.

Figs. 1 to 5 show at least parts of preferred embodiments of a reinforcing element 1 for a concrete barrier-wall element 3 having a repelling profile on at least one longitudinal side 2. The reinforcing element 1 is provided for use in a concrete barrier-wall element 3, which concrete barrier-wall element 3 has at least one longitudinal side 2 with a repelling profile. The repelling profile is a characteristic profile for a concrete barrier-wall element 3 of vehicle retention systems, which ensures that a vehicle driving against the longitudinal side 2 at an angle does not bounce off, but is deflected in a travelling direction parallel to the longitudinal side 2.

It is intended that the reinforcing element 1 has longitudinal reinforcing bars 4 and has bows 5, which extend transversely to the longitudinal reinforcing bars 4 and are connected, preferably welded, to the longitudinal reinforcing bars 4. The longitudinal

reinforcing bars 4 are intended to extend in the longitudinal direction in the concrete barrier-wall element 3. The longitudinal reinforcing bars 4 are connected to each other by means of bows 5. A two-dimensional curved grid is preferably constructed by means of the longitudinal reinforcing bars 4 and the bows 5. The bows 5 can extend in particular perpendicularly to the longitudinal reinforcing bars 4. Only part of the longitudinal reinforcement bars 3 and bows 5 are provided with reference signs in Figs. 1, 2 and 4.

The reinforcing element 1 preferably consists of the longitudinal reinforcing bars 4 and the bows 5.

Moreover, it is intended that the reinforcing element 1 has at least one first region 6 and the first region 6 largely has the repelling profile. Here, the reinforcing element 1 can consist of only the first region 6, or comprise further areas 7, 9. The first region 6 is substantially formed like the repelling profile of the concrete barrier-wall element 3 to be produced. The first region 6 can be designed in particular substantially like the at least one longitudinal side 2 of the concrete barrier-wall element 3. Thus, the first region 6 of the reinforcing element 1 in the concrete body of the concrete barrier-wall element 3 can substantially be arranged to follow the course of the at least one longitudinal side 2 of the concrete barrier-wall element 3.

This provides the advantage that it is possible to produce concrete barrier-wall elements 3 with less effort but higher reliability. In this case, the longitudinal reinforcing bars 4 and bows 5 are already formed in such a way that at least in some regions they have the repelling profile of the concrete barrier-wall element 3 to be produced, so that a very stable reinforcement can be positioned close to the relevant surfaces. As a result, there is no need for a complex construction with filigree reinforcing steel mats at exposed points. A further advantage is that the previous overlaps of the longitudinal reinforcing bars, bows and reinforcing steel mats is reduced to overlapping of the longitudinal reinforcing bars with the bows. Moreover, the reinforcing elements 1 can be prefabricated in large quantities and then delivered to the concrete plants, where the concrete barrier-wall elements 3 are then cast. As a result, a significantly more economic production is possible, but also with narrower production tolerances.

The longitudinal reinforcing bars 4 can be in particular straight.

The longitudinal reinforcing bars 4 can be made in particular of reinforcing steel.

All longitudinal reinforcing bars 4 of a reinforcing element 1 can be in particular of the same design.

The bows 5 can preferably be designed as reinforcing bars bent at an angle, in particular with a predeterminable radius. The bows can be designed so as to extend in the first region 6 in particular following the repelling profile.

The bows 5 can preferably be made of rigid reinforcing bars.

The bows 5 can be made in particular of reinforcing steel.

All bows 5 of a reinforcing element 1 can be in particular of the same design.

The longitudinal reinforcing bars 4 and the bows 5 can preferably be welded to each other.

Furthermore, a concrete barrier-wall element 3 for a vehicle retention system is provided, which concrete barrier-wall element 3 has the repelling profile on at least one longitudinal side 2, wherein the reinforcing element 1 is arranged close to the surface in the region of the at least one longitudinal side 2. The concrete barrier-wall element 3 has a concrete body which is shown in a transparent manner in Figs. 1 to 4, in which the reinforcing element 1 or elements are arranged. The arrangement close to the surface can mean, in particular, that the reinforcing element 1 is arranged at a depth of maximum 10 cm to the surface of the concrete body.

The concrete barrier-wall element 3 can have in particular two longitudinal sides 2, two face sides 10, an upper side 8, as well as a base.

At least one of the longitudinal sides 2 has the repelling profile.

Preferably, both longitudinal sides 2 can have the repelling profile, as shown by way of example in the preferred embodiments in Figs. 1 to 4.

The length of the longitudinal reinforcing bars 4 can correspond in particular largely to the length of the concrete barrier-wall element 3.

The bows can preferably run largely from the base to at least largely the upper side 8.

The concrete barrier-wall element 3 may further be provided with coupling devices arranged on the face sides, not shown in the figures, for coupling a plurality of concrete barrier-wall elements 3 at the face sides. The coupling devices on both face sides 10 can be connected in particular to the reinforcing elements 1 and/or additional tiebacks.

Furthermore, a method is provided for producing the concrete barrier-wall element 3 having a repelling profile on at least one longitudinal side 2, wherein the longitudinal reinforcing bars 4 and the bows 5, which extend transversely to the longitudinal reinforcing bars 4, are connected together to form the reinforcing element 1, which reinforcing element 1 has at least the one first region 6 and the first region 6 largely has the repelling profile, wherein at least one of the reinforcing elements 1 is introduced into a casting mould in such a way that the at least one reinforcing element 1 is arranged close to the surface in the region of the at least one longitudinal side 2 in the finished concrete barrier-wall element 3, wherein the casting mould is cast with concrete to form the concrete barrier-wall element 3.

The longitudinal reinforcing bars 4 and the bows 5 are preferably connected by welding.

In particular, the longitudinal reinforcing bars 4 and the bows 5 can be welded to each other, and the bows 5 can then be bent into the form of the repelling profile.

Alternatively, the bows 5 can be first bent and then welded to the longitudinal reinforcing bars 4.

It can preferably be provided that the reinforcing elements 1 are produced at least partially, preferably completely, by machine. In particular, bending of the bows 5 and welding can take place in a plant. Alternatively, the reinforcing elements 1 can be implemented in a combination of machine and hand welding.

It is especially preferred to provide that the repelling profile is a New Jersey profile or a

step profile. In the preferred embodiments in Figs. 1 to 4, the repelling profile is the New Jersey profile. In the vicinity of the base, the New Jersey profile has a run-on surface which passes into a steeper repelling surface. The New Jersey profile is a repelling profile which is very frequently used in concrete barrier-wall elements 3. The step profile has two regions which run parallel to one another and are offset relative to one another by a small step. In the first region 6, in particular, the bows 5 can be designed following the course of the New Jersey profile or the step profile.

It is preferably possible to provide that the longitudinal reinforcing bars 4 have a different diameter than the bows 5. In particular, it is possible to provide that all longitudinal reinforcing bars 4 have a first diameter, that all bows 5 have a second diameter, and that the first diameter is not equal to the second diameter. In this case, the first diameter and the second diameter can be selected such that the diameters are adapted to the retention requirements and the weakening at the bending points on the bows 5 can be compensated.

It is also possible to provide that a distance between the bows 5 is variable with respect to one another, and in particular is smaller in a region of the ends of the longitudinal reinforcing bars 4 than in a central region of the longitudinal reinforcing bars 4. This way, more reinforcing material is arranged in the vicinity of the face sides 10, where the danger of damage and spalling is higher.

In particular, it is possible to provide that a distance between the longitudinal reinforcing bars 4 is variable with respect to one another, and in particular is smaller in edge regions of the repelling profile than in a central region of the repelling profile. This way, more reinforcing material is arranged in the vicinity of the upper side 8 arranged at the edges of the repelling profile as well as the base, where the danger of damage and spalling is higher.

It is also possible to provide that a distance between the longitudinal reinforcing bars 4 is smaller with respect to one another in a region of the ends of the bows 5 than in a central region of the bows 5. This way, it is possible to achieve a stronger reinforcement at the free ends of the bows, where loads may be greater.

It is also possible to provide that a distance between the longitudinal reinforcing bars 4 is variable with respect to one another, and in particular is smaller at the edges of the first region 6 than in the middle of the first region 6. This way, there is more reinforcing material in the vicinity of the base and the upper side 8, where the danger of damage and spalling is higher.

It is preferably possible to provide that the reinforcing element 1 is flat. In this case, the reinforcing element 1 can be formed substantially like a curved surface. The advantage of this is that the reinforcing elements 1 can be stacked easily and thus transported in a space-saving manner. A stack of reinforcing elements 1 of the second preferred embodiment is shown in Fig. 5 by way of example.

It is possible to provide that the reinforcement of the concrete barrier-wall element 3 formed by at least one reinforcing element 1 is open at the face side 10.

It is possible to provide that the reinforcing element 1 consists only of the first region 6.

It is also possible to provide that a second region 7 adjoins the first region 6, that the second region 7 is angled relative to the first region 6 and is provided to be arranged on an upper side 8 of the concrete barrier-wall element 3. The second region 7 can extend over at least half the width of the upper side 8. This way, the upper side 8 can also be reinforced.

In particular, it is possible to provide that a third region 9 adjoins the second region 7 on a side of the second region 7 facing away from the first region 6, and that the third region 9 largely has the repelling profile. In this case, the first region 6, the second region 7 and the third region 9 substantially form the profile of the two longitudinal sides 2 together with the upper side 8 of the concrete barrier-wall element 3 to be produced. It is possible, in the case of the concrete barrier-wall element 3, to provide that the concrete barrier-wall element 3 has two longitudinal sides 2 having a repelling profile, and that a single reinforcing element 1 is arranged on both longitudinal sides 2. In particular, it is possible to provide that the concrete barrier-wall element 3 has only a single reinforcing element 1. This way, it is possible to achieve a reinforcement of all exposed surfaces of a concrete barrier-wall element 3 by substantially a single

prefabricated reinforcing element 1. A concrete barrier-wall element 3 of this type is shown by way of example in Fig. 1.

Alternatively, it is possible, in the case of a reinforcing element 1 made up of a plurality of regions 6,7, to provide that only the first region 6 has the repelling profile.

It is preferably possible to provide that the reinforcing element 1 has only the first region 6 and the second region 7.

In particular, it is possible to provide that the concrete barrier-wall element 3 has two longitudinal sides 2 having a repelling profile, and that one reinforcing element 1 each is arranged on both longitudinal sides 2.

In this case, the concrete barrier-wall element 3 can preferably have two, in particular largely equally formed reinforcing elements 1, wherein it is especially preferred that one of the reinforcing elements 1 each is arranged on one of the longitudinal sides 2. This multi-part construction of the reinforcement makes it possible to simplify the handling of the reinforcing elements 1. Furthermore, the stackability is improved. In addition, reinforcing elements 1 of this type can also be used in the case of a concrete barrier-wall element 3 having only one longitudinal side 2 with the repelling profile. Reinforcing elements 1 formed in this way are shown by way of example in Figs. 2 to 5, wherein in Fig. 2 both reinforcing elements 1 are shown joined together, while in Fig. 4 one reinforcing element 1 is shown inside the concrete body and the other reinforcing element 1 outside the concrete body.

It is preferably possible to provide that the two reinforcing elements 1 adjoin one another, in particular overlap in the region of an upper side 8 of the concrete barrier-wall element 3. This way, the two reinforcement elements 1 can be connected to each other in a simple manner in the region of the upper side 8. In this case, the bows 5 of the two reinforcing elements 1 can be set off slightly in relation to one another in such a way that they are arranged next to each other in the second region 7.

CLAIMS

1. Reinforcing element (1) for a concrete barrier-wall element (3), which concrete barrier-wall element has a repelling profile on at least one longitudinal side (2), wherein the repelling profile is a New Jersey profile or a step profile, wherein the reinforcing element (1) has longitudinal reinforcing bars (4) and has bows (5), which extend transversely to the longitudinal reinforcing bars (4) and are connected to the longitudinal reinforcing bars (4), that the reinforcing element (1) has at least a first region (6), that the first region (6) is substantially formed like the repelling profile of the concrete barrier-wall element (3) to be produced, **characterized in that** the longitudinal reinforcing bars (4) and the bows (5) make up a two-dimensional curved grid, and that the reinforcing element (1) is formed substantially like a curved surface.
2. Reinforcing element (1) according to claim 1, **characterized in that** a distance between the bows (5) is variable with respect to one another, and in particular is smaller in a region of the ends of the longitudinal reinforcing bars (4) than in a central region of the longitudinal reinforcing bars (4).
3. Reinforcing element (1) according to claim 1 or 2, **characterized in that** a distance between the longitudinal reinforcing bars (4) is variable with respect to one another, and in particular is smaller in edge regions of the repelling profile than in a central region of the repelling profile.
4. Reinforcing element (1) according to one of claims 1 to 3, **characterized in that** a distance between the longitudinal reinforcing bars (4) is smaller with respect to one another in a region of the ends of the bows (5) than in a central region of the bows (5).

5. Reinforcing element (1) according to one of claims 1 to 4, **characterized in that** the longitudinal reinforcing bars (4) have a different diameter than the bows (5).
6. Reinforcing element (1) according to one of claims 1 to 5, **characterized in that** a second region (7) adjoins the first region (6), that the second region (7) is angled relative to the first region (6) and is provided to be arranged on an upper side (8) of the concrete barrier-wall element (3).
7. Reinforcing element (1) according to claim 6, **characterized in that** the reinforcing element (1) has only the first region (6) and the second region (7).
8. Reinforcing element (1) according to claim 6, **characterized in that** a third region (9) adjoins the second region (7) on a side of the second region (7) facing away from the first region (6), and that the third region (9) largely has the repelling profile.
9. Concrete barrier-wall element (3) for a vehicle retention system, which concrete barrier-wall element (3) has a repelling profile on at least one longitudinal side (2), wherein a reinforcing element (1) according to one of claims 1 to 8 is arranged close to the surface in the region of the at least one longitudinal side (2).
10. Concrete barrier-wall element (3) according to claim 9, **characterized in that** the concrete barrier-wall element (3) has two longitudinal sides (2) having a repelling profile, and that one reinforcing element (1) each is arranged on both longitudinal sides (2).
11. Concrete barrier-wall element (3) according to claim 9 or 10, **characterized in that** the two reinforcing elements (1) at least adjoin one another, in particular overlap in the region of an upper side (8) of the concrete barrier-wall element (3).
12. Concrete barrier-wall element (3) according to claim 9, **characterized in that**

the concrete barrier-wall element (3) has two longitudinal sides (2) having a repelling profile, and that a single reinforcing element (1) is arranged on both longitudinal sides (2).

13. Method for producing a concrete barrier-wall element (3) having a repelling profile on at least one longitudinal side (2), wherein the repelling profile is a New Jersey profile or a step profile, wherein longitudinal reinforcing bars (4) and bows (5), which extend transversely to the longitudinal reinforcing bars (4), are connected together to form a reinforcing element (1), which reinforcing element (1) has at least one first region (6), wherein the first region (6) is substantially formed like the repelling profile of the concrete barrier-wall element (3) to be produced, wherein a two-dimensional curved grid is constructed by means of the longitudinal reinforcing bars (4) and the bows (5), wherein the reinforcing element (1) is formed substantially like a curved surface, wherein at least one of the reinforcing elements (1) is introduced into a casting mould in such a way that the at least one reinforcing element (1) is arranged close to the surface in the region of the at least one longitudinal side (2) in the finished concrete barrier-wall element (3), wherein the casting mould is cast with concrete to form the concrete barrier-wall element (3).

14. Method according to claim 13, **characterized in that** the reinforcing elements (1) are machine-made.

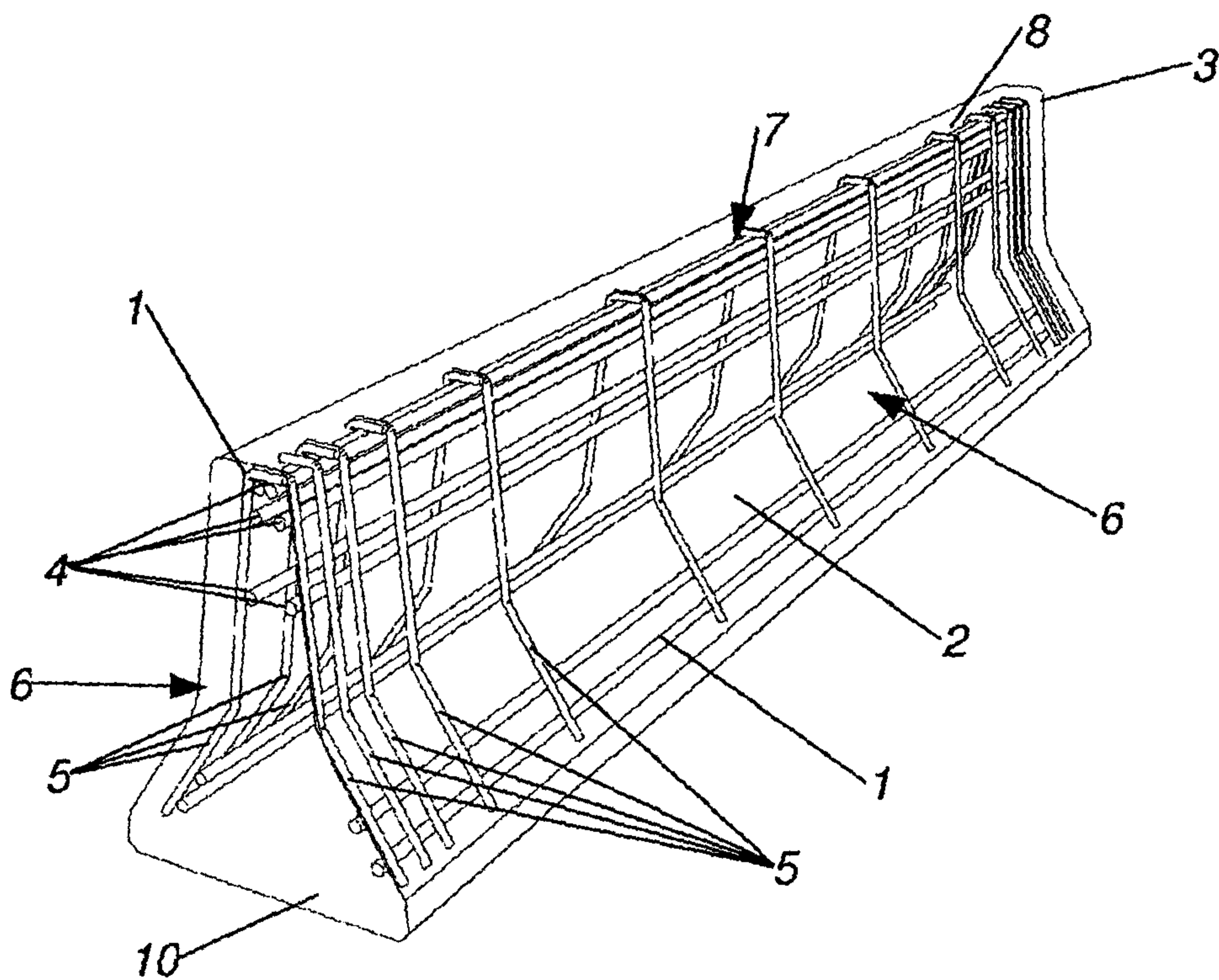
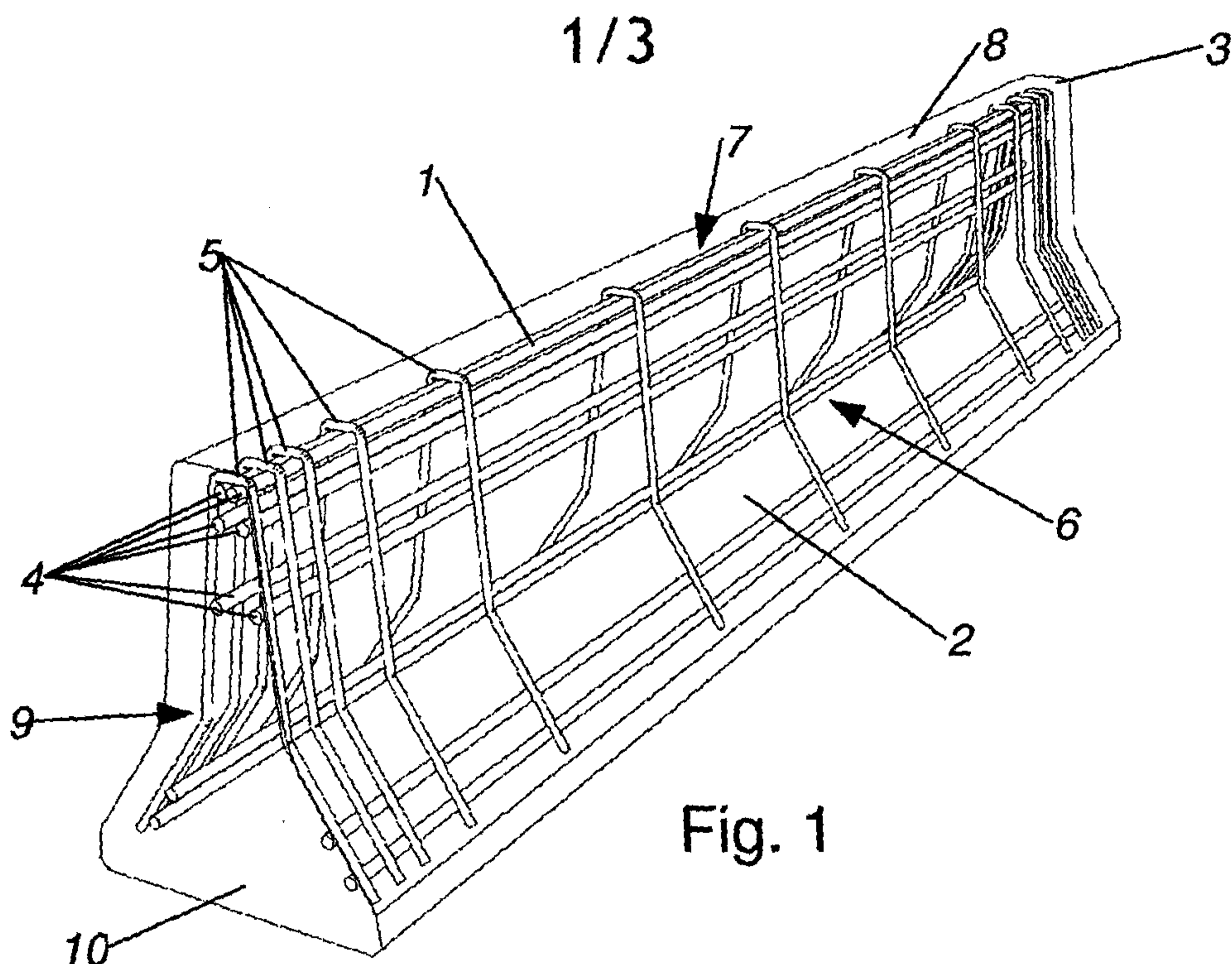

2/3

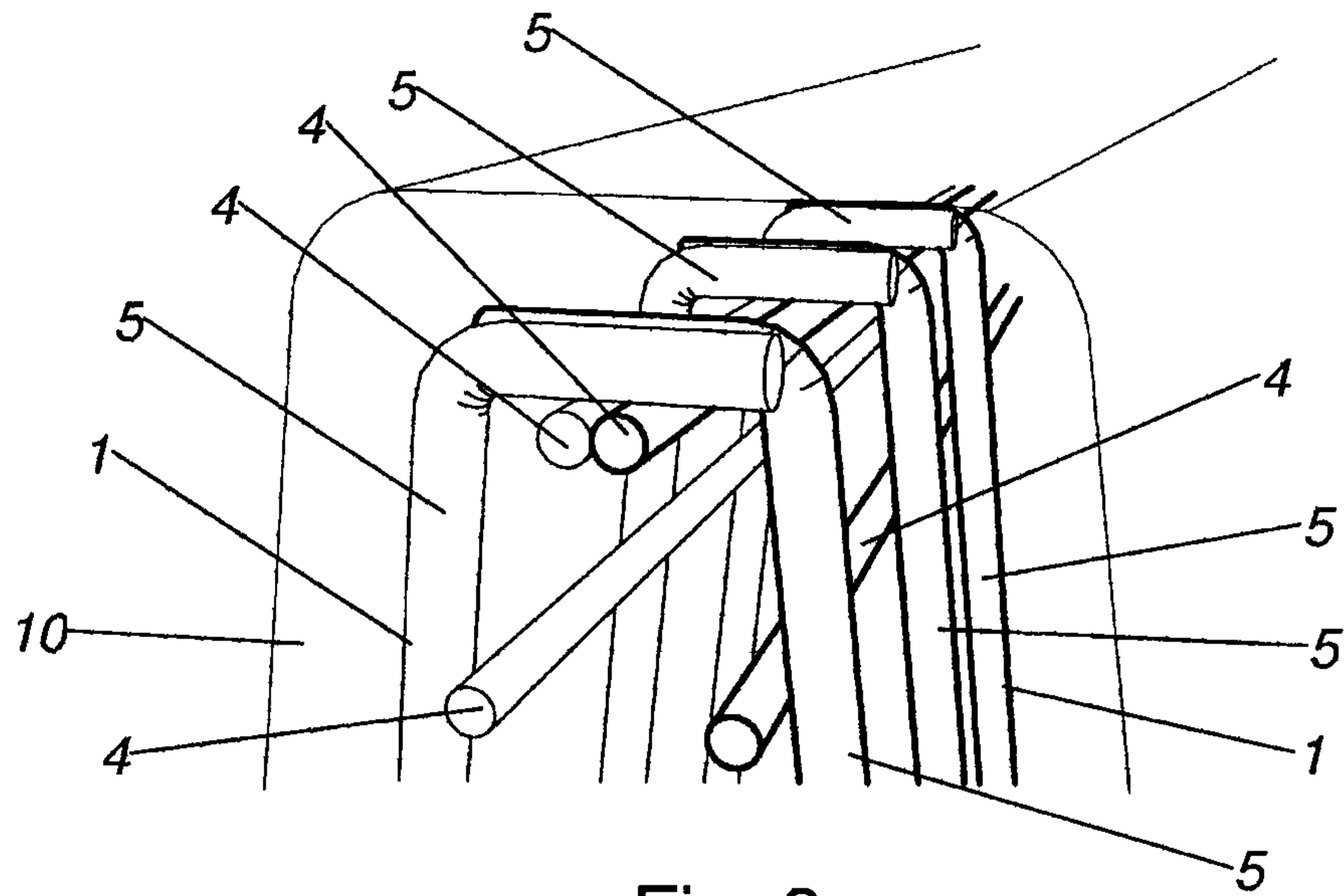

Fig. 3

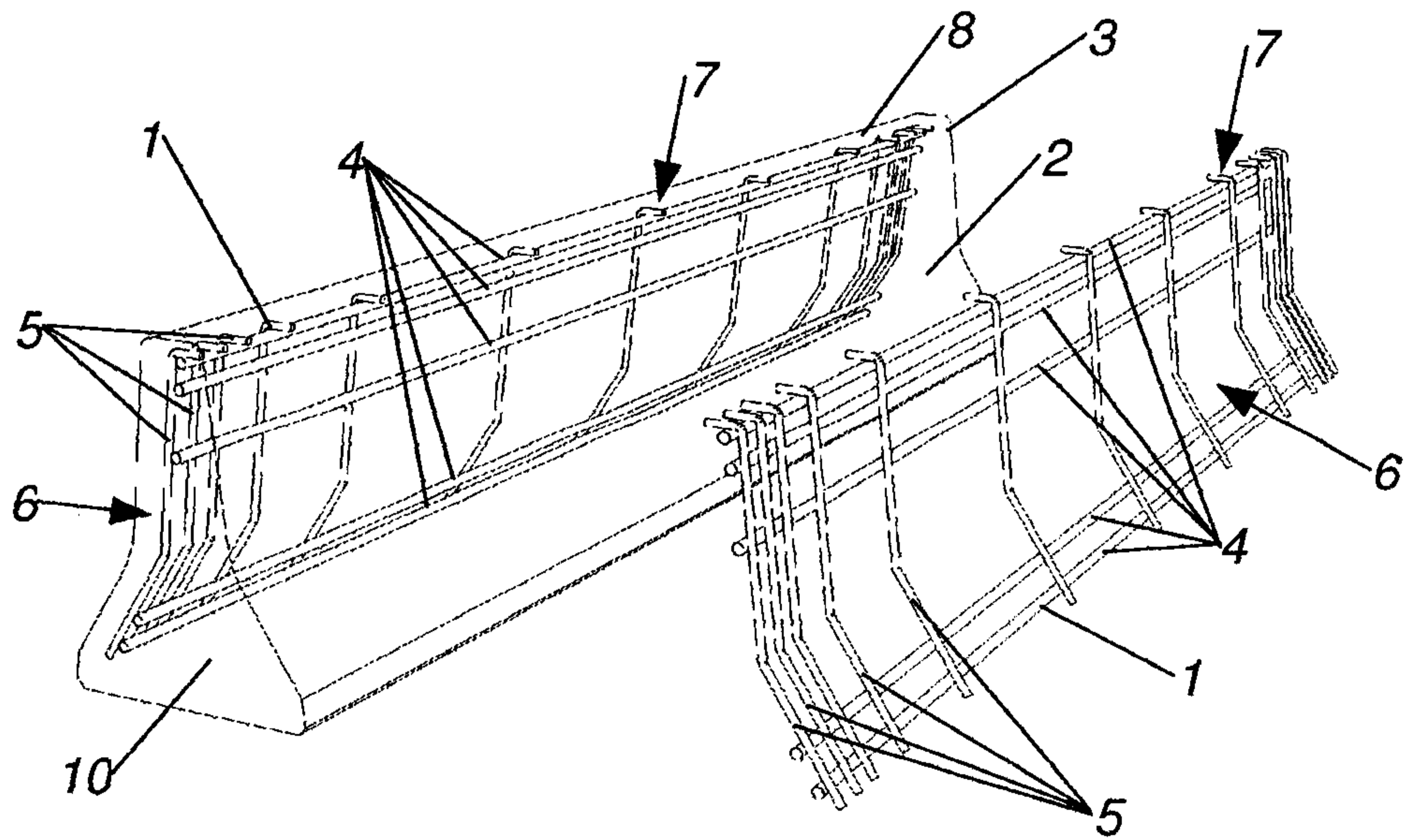

Fig. 4

3/3

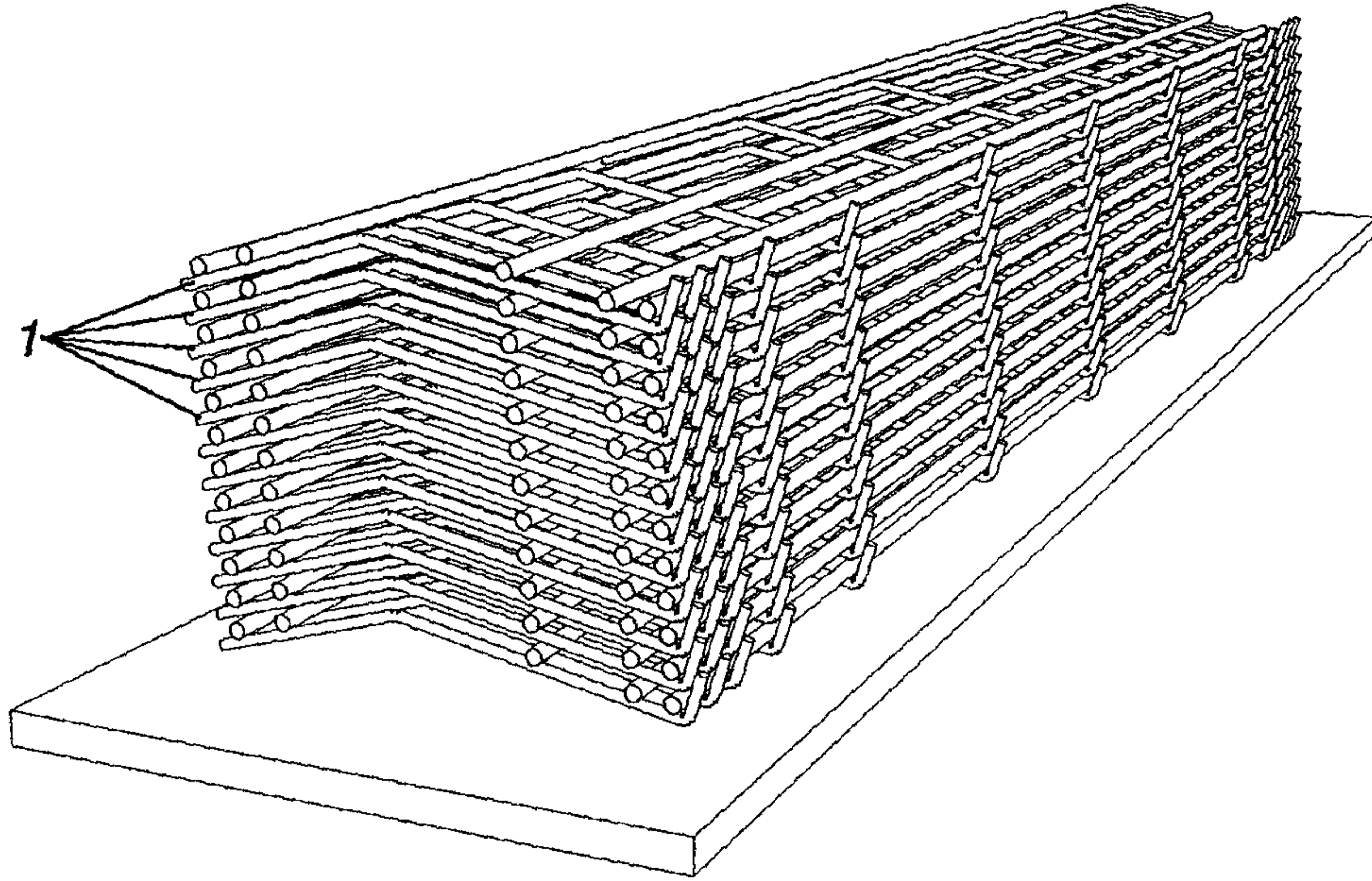

Fig. 5

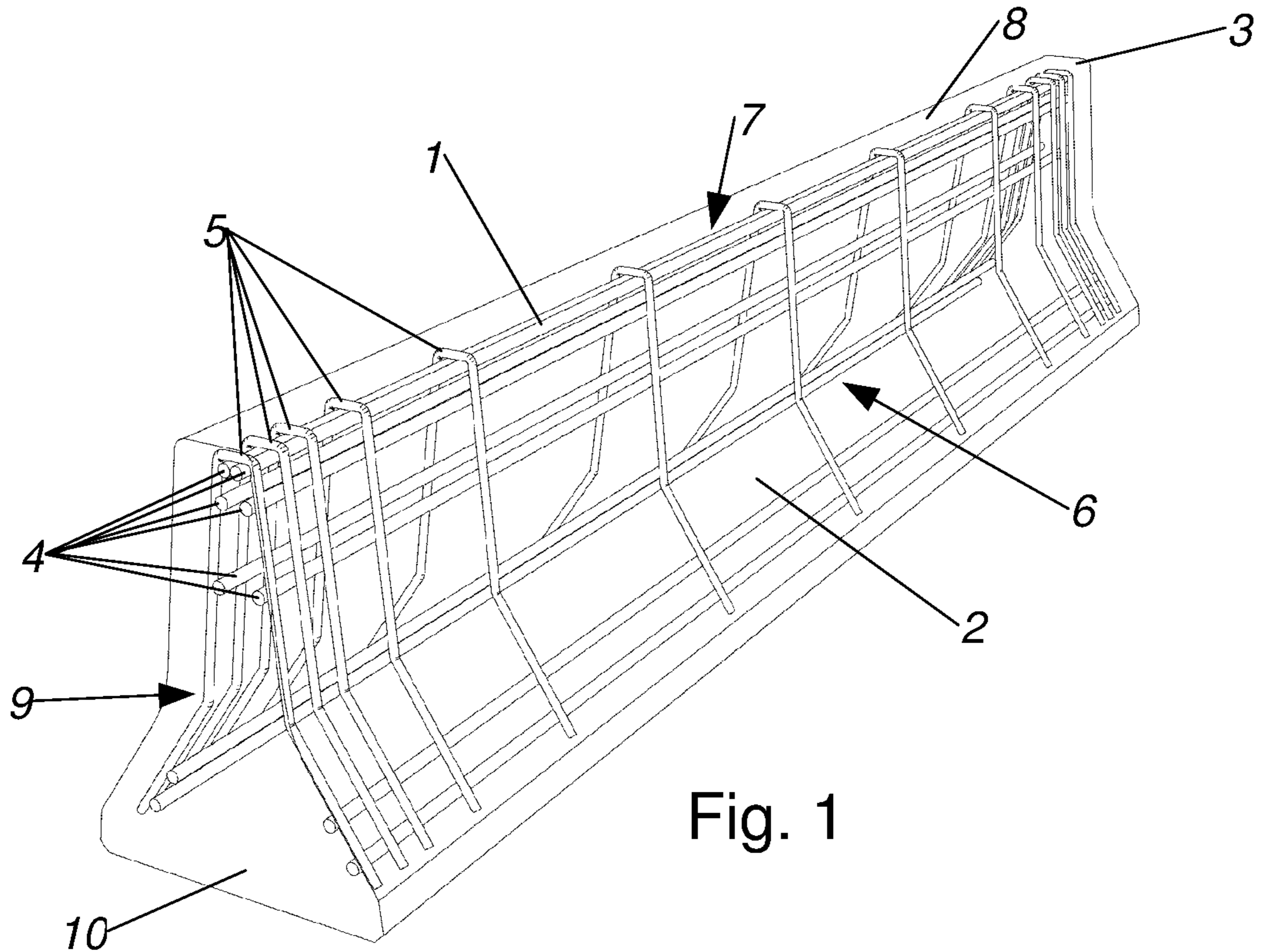

Fig. 1