



- (51) International Patent Classification:
H03M 3/04 (2006.01)
- (21) International Application Number:
PCT/US2014/033314
- (22) International Filing Date:
8 April 2014 (08.04.2014)
- (25) Filing Language: English
- (26) Publication Language: English
- (30) Priority Data:
61/810,075 9 April 2013 (09.04.2013) US
- (71) Applicant: CIRRUS LOGIC, INC. [US/US]; 2901 Via Fortuna, Austin, Texas 78746 (US).
- (72) Inventors: MELANSON, John L.; 901 West 9th Street, #201, Austin, Texas 78703 (US). TUCKER, John C.; 5913 Republic of Texas Blvd., Austin, Texas 78735 (US).
- (74) Agents: PREWITT, Brian K. et al.; Jackson Walker L.L.P., 100 Congress Avenue, Suite 1100, Austin, Texas 78701 (US).
- (81) Designated States (unless otherwise indicated, for every kind of national protection available): AE, AG, AL, AM,

AO, AT, AU, AZ, BA, BB, BG, BH, BN, BR, BW, BY, BZ, CA, CH, CL, CN, CO, CR, CU, CZ, DE, DK, DM, DO, DZ, EC, EE, EG, ES, FI, GB, GD, GE, GH, GM, GT, HN, HR, HU, ID, IL, IN, IR, IS, JP, KE, KG, KN, KP, KR, KZ, LA, LC, LK, LR, LS, LT, LU, LY, MA, MD, ME, MG, MK, MN, MW, MX, MY, MZ, NA, NG, NI, NO, NZ, OM, PA, PE, PG, PH, PL, PT, QA, RO, RS, RU, RW, SA, SC, SD, SE, SG, SK, SL, SM, ST, SV, SY, TH, TJ, TM, TN, TR, TT, TZ, UA, UG, US, UZ, VC, VN, ZA, ZM, ZW.

- (84) Designated States (unless otherwise indicated, for every kind of regional protection available): ARIPO (BW, GH, GM, KE, LR, LS, MW, MZ, NA, RW, SD, SL, SZ, TZ, UG, ZM, ZW), Eurasian (AM, AZ, BY, KG, KZ, RU, TJ, TM), European (AL, AT, BE, BG, CH, CY, CZ, DE, DK, EE, ES, FI, FR, GB, GR, HR, HU, IE, IS, IT, LT, LU, LV, MC, MK, MT, NL, NO, PL, PT, RO, RS, SE, SI, SK, SM, TR), OAPI (BF, BJ, CF, CG, CI, CM, GA, GN, GQ, GW, KM, ML, MR, NE, SN, TD, TG).

Published:

- without international search report and to be republished upon receipt of that report (Rule 48.2(g))



WO 2014/168939 A2

(54) Title: SYSTEMS AND METHODS FOR COMPRESSING A DIGITAL SIGNAL IN A DIGITAL MICROPHONE SYSTEM

(57) Abstract: In accordance with embodiments of the present disclosure, a digital microphone system may include a microphone transducer and a digital processing system. The microphone transducer may be configured to generate an analog input signal indicative of audio sounds incident upon the microphone transducer. The digital processing system may be configured to convert the analog input signal into a first digital signal having a plurality (e.g., more than 3) of quantization levels, and in the digital domain, process the first digital signal to compress the first digital signal into a second digital signal having fewer quantization levels (e.g., +1, 0, -1) than that of the first digital signal.

SYSTEMS AND METHODS FOR COMPRESSING A DIGITAL SIGNAL IN A DIGITAL MICROPHONE SYSTEM

RELATED APPLICATIONS

The present disclosure claims priority to United States Provisional Patent
5 Application Serial No. 61/810,075, filed April 9, 2013, which is incorporated by
reference herein in its entirety.

FIELD OF DISCLOSURE

The present disclosure relates in general to audio systems, and more particularly,
10 to compressing a digital signal in a digital microphone system.

BACKGROUND

Microphones are ubiquitous on many devices used by individuals, including
computers, tablets, smart phones, and many other consumer devices. Generally speaking,
15 a microphone is an electroacoustic transducer that produces an electrical signal in
response to deflection of a portion (e.g., a membrane or other structure) of a microphone
caused by sound incident upon the microphone.

In a digital microphone system, an analog output signal of the microphone
transducer may be processed by an analog-to-digital converter to convert the analog
20 output signal to a digital output signal, which may be communicated over a bus to a
digital audio processor for further processing. By communicating a digital signal over the
bus rather than an analog signal, the audio signal may be less susceptible to noise.

To adequately represent an audio signal with sufficient quality, the digital output
signal may have numerous quantization levels. Numerous quantization levels may
25 require a significant number of digital bits in order that each quantization level is
represented by a corresponding digital code. It may be undesirable to transmit digital
codes with many bits over a digital bus, particularly a serial digital bus, as communication
throughput may decrease as the number of bits in digital codes increase.

SUMMARY

In accordance with the teachings of the present disclosure, certain disadvantages and problems associated with communication of a microphone signal may be reduced or eliminated.

5 In accordance with embodiments of the present disclosure, a digital microphone system may include a microphone transducer and a digital processing system. The microphone transducer may be configured to generate an analog input signal indicative of audio sounds incident upon the microphone transducer. The digital processing system may be configured to convert the analog input signal into a first digital signal having a
10 plurality of quantization levels, and, in the digital domain, process the first digital signal to compress the first digital signal into a second digital signal having fewer quantization levels than that of the first digital signal.

In accordance with these and other embodiments of the present disclosure, a system may include a microphone transducer and a digital processing system. The
15 microphone transducer may be configured to generate an analog input signal indicative of audio sounds incident upon the microphone transducer. The digital processing system may be configured to convert the analog input signal into a digital signal having a plurality of quantization levels, such that each quantization level of the digital signal is represented by one or more transitions or one or more absences of transitions of one or
20 more bits of the digital signal.

In accordance with these and other embodiments of the present disclosure, a method may include generating an analog input signal indicative of audio sounds incident upon a microphone transducer. The method may also include converting the analog input
25 signal into a first digital signal having a plurality of quantization levels. The method may further include, in the digital domain, processing the first digital signal to compress the first digital signal into a second digital signal having fewer quantization levels than that of the first digital signal.

In accordance with these and other embodiments of the present disclosure, a method may include generating an analog input signal indicative of audio sounds incident
30 upon a microphone transducer. The method may also include converting the analog input signal into a digital signal having a plurality of quantization levels, such that each

quantization level of the digital signal is represented by one or more transitions or one or more absences of transitions of one or more bits of the digital signal.

In accordance with these and other embodiments of the present disclosure, an integrated circuit may include a microphone input and a processing circuit. The microphone input may be configured to receive an analog input signal indicative of audio sounds incident upon a microphone transducer. The processing circuit may be configured to convert the analog input signal into a first digital signal having a plurality of quantization levels and, in the digital domain, process the first digital signal to compress the first digital signal into a second digital signal having fewer quantization levels than that of the first digital signal.

In accordance with these and other embodiments of the present disclosure, an integrated circuit may include a microphone input and a processing circuit. The microphone input may be configured to receive an analog input signal indicative of audio sounds incident upon a microphone transducer. The processing circuit may be configured to convert the analog input signal into a digital signal having a plurality of quantization levels, such that each quantization level is represented by one or more transitions or one or more absences of transitions of one or more bits of the digital signal.

Technical advantages of the present disclosure may be readily apparent to one having ordinary skill in the art from the figures, description and claims included herein. The objects and advantages of the embodiments will be realized and achieved at least by the elements, features, and combinations particularly pointed out in the claims.

It is to be understood that both the foregoing general description and the following detailed description are explanatory examples and are not restrictive of the claims set forth in this disclosure.

25

BRIEF DESCRIPTION OF THE DRAWINGS

A more complete understanding of the present embodiments and advantages thereof may be acquired by referring to the following description taken in conjunction with the accompanying drawings, in which like reference numbers indicate like features, and wherein:

30

FIGURE 1 illustrates a block diagram of selected components of an example audio system, in accordance with embodiments of the present disclosure;

FIGURE 2 illustrates a block diagram of selected components of a digital microphone integrated circuit, in accordance with embodiments of the present disclosure;

5 FIGURE 3 illustrates a block diagram of selected components of a delta-sigma modulator, which may be used to implement the analog-to-digital converter depicted in FIGURE 2, in accordance with embodiments of the present disclosure;

FIGURE 4 illustrates a block diagram of selected components of a quantizer, in accordance with embodiments of the present disclosure; and

10 FIGURE 5 illustrates graphs depicting example coding of a digital signal, in accordance with embodiments of the present disclosure.

DETAILED DESCRIPTION

FIGURE 1 illustrates a block diagram of selected components of an example audio system 100, in accordance with embodiments of the present disclosure. As shown in FIGURE 1, audio system 100 may include a microphone transducer 101, a digital microphone integrated circuit (IC) 105, and a digital audio processor 109. Microphone transducer 101 may comprise any system, device, or apparatus configured to convert sound incident at microphone transducer 101 to an electrical signal, for example an analog output signal ANALOG_OUT, wherein such sound is converted to an electrical signal using a diaphragm or membrane having an electrical capacitance that varies as based on sonic vibrations received at the diaphragm or membrane. Microphone transducer 101 may include an electrostatic microphone, a condenser microphone, an electret microphone, a microelectromechanical systems (MEMs) microphone, or any other suitable capacitive microphone.

Digital microphone IC 105 may comprise any suitable system, device, or apparatus configured to process analog output signal ANALOG_OUT to generate a digital audio output signal DIGITAL_BUS and condition digital audio output signal DIGITAL_BUS for transmission over a bus to digital audio processor 109. Once converted to digital audio output signal DIGITAL_BUS, the audio signal may be transmitted over significantly longer distances without being susceptible to noise as

compared to an analog transmission over the same distance. In some embodiments, digital microphone IC 105 may be disposed in close proximity with microphone transducer 101 to ensure that the length of the analog line between microphone transducer 101 and digital microphone IC 105 is relatively short to minimize the amount of noise that can be picked up on an analog output line carrying analog output signal ANALOG_OUT. For example, in some embodiments, microphone transducer 101 and digital microphone IC 105 may be formed on the same substrate. In other embodiments, microphone transducer 101 and digital microphone IC 105 may be formed on different substrates packaged within the same integrated circuit package.

Digital audio processor 109 may comprise any suitable system, device, or apparatus configured to process digital audio output signal for use in a digital audio system. For example, digital audio processor 109 may comprise a microprocessor, microcontroller, digital signal processor (DSP), application specific integrated circuit (ASIC), or any other device configured to interpret and/or execute program instructions and/or process data, such as digital audio output signal.

FIGURE 2 illustrates a block diagram of selected components of digital microphone IC 105, in accordance with embodiments of the present disclosure. As shown in FIGURE 2, digital microphone IC 105 may include a pre-amplifier 203, an analog-to-digital converter (ADC) 215, and a driver 219. Pre-amplifier 203 may receive analog output signal ANALOG_OUT via one or more input lines which may allow for receipt of a single-ended signal, differential signal, or any other suitable analog audio signal format and may comprise any suitable system, device, or apparatus configured to condition analog output signal ANALOG_OUT for processing by ADC 215. The output of pre-amplifier 203 may be communicated to ADC 215 on one or more output lines.

ADC 215 may comprise any suitable system device or apparatus configured to convert an analog audio signal received at its input, to a digital signal representative of analog output signal ANALOG_OUT. ADC 215 may itself include one or more components (e.g., delta-sigma modulator, decimator, etc.) for carrying out the functionality of ADC 215.

Driver 219 may receive the digital signal DIGITAL_OUT output by ADC 215 and may comprise any suitable system, device, or apparatus configured to condition such

digital signal (e.g., encoding into Audio Engineering Society/European Broadcasting Union (AES/EBU), Sony/Philips Digital Interface Format (S/PDIF), in the process generating digital audio output signal DIGITAL_BUS for transmission over a bus to digital audio processor 109. In FIGURE 2, the bus receiving digital audio output signal DIGITAL_BUS is shown as single-ended. In some embodiments, driver 219 may generate a differential digital audio output signal 107.

FIGURE 3 illustrates a block diagram of selected components of a delta-sigma modulator 300, which may be used to implement ADC 215 depicted in FIGURE 2, in accordance with embodiments of the present disclosure. As shown in FIGURE 3, modulator 300 may include a loop filter 302, a quantizer 304, dynamic element matching circuitry (DEM) 306, a digital-to-analog converter (DAC) 308, and a delay block 312. Loop filter 302 may comprise an input summer for generating a difference between amplified analog output signal ANALOG_AMP and an analog feedback signal ANALOG_FB, and one or more integrator stages 310, such that loop filter 302 operates as analog filter of an error signal equal to the difference between amplified analog output signal ANALOG_AMP and analog feedback signal ANALOG_FB, and generates a filtered output analog signal to quantizer 304 based on amplified analog output signal ANALOG_AMP and analog feedback signal ANALOG_FB (e.g., amplified analog output signal ANALOG_AMP plus a filtered version of analog feedback signal ANALOG_FB). The output from loop filter 302 may be quantized by a quantizer 304 which may, as described in greater detail below, convert the analog input signal into a first digital signal having a plurality of quantization levels and, in the digital domain, process the first digital signal to compress the first digital signal into a second digital signal having fewer quantization levels than that of the first digital signal. Quantizer 304 may also be configured to generate a digital feedback signal DIGITAL_INT. Digital feedback signal DIGITAL_INT may be delayed by delay block 312 and fed back through DEM circuitry 306 and DAC 308 to generate analog feedback signal ANALOG_FB.

FIGURE 4 illustrates a block diagram of selected components of a quantizer 304, in accordance with embodiments of the present disclosure. As shown in FIGURE 4, quantizer 304 may include a multi-bit quantizer 402, reduced quantization level quantizer 404, and digital summer 406. Multi-bit quantizer 402 may be configured to receive the

analog output from loop filter 302, and convert the analog output into a first digital signal DIGITAL_INT having a plurality of quantization levels (e.g., more than three), as is known in the art. In some embodiments, first digital signal DIGITAL_INT may be a signal of length N, where N is a positive integer. In particular embodiments, N may be greater or equal to 3. First digital signal DIGITAL_INT may be fed back to loop filter 302.

Reduced quantization level quantizer 404 may in turn process the first digital signal to compress first digital signal DIGITAL_INT into a second digital signal (e.g., DIGITAL_OUT) having fewer quantization levels than that of first digital signal DIGITAL_INT. In some embodiments, second digital signal DIGITAL_OUT may be a signal of length M, where M is a positive integer less than N. In particular embodiments, M may equal to 1 or 2. As a particular example, in some embodiments, reduced quantization level quantizer 404 may generate output signals having three quantization levels: a first quantization level that corresponds to an increase in the first digital signal equal to one quantization level of first digital signal DIGITAL_INT (e.g., +1), a second quantization level that corresponds to no change of the quantization level of first digital signal DIGITAL_INT (e.g., 0), and a third quantization level that corresponds to a decrease in the first digital signal equal to one quantization level of first digital signal (e.g., -1) DIGITAL_INT. In this disclosure, the compression of the audio signal to three quantization levels may not lower fidelity of the analog-to-digital conversion performed by modulator 300, as the full, uncompressed digital signal DIGITAL_INT is fed back to loop filter 302.

As shown in FIGURE 4, the second digital signal (e.g., DIGITAL_OUT) generated by reduced quantization level quantizer 404 may be based not only on first digital signal DIGITAL_INT, but also on a previous value of a digital signal DIGITAL_FB. Digital feedback signal DIGITAL_FB may be generated by digital summer 406 which has the same number of quantization levels as first digital signal DIGITAL_INT, and may be equal to a previous value of digital feedback signal DIGITAL_FB plus the current value of DIGITAL_OUT. In other words, when second digital signal DIGITAL_OUT has one of three quantization levels (e.g., -1, 0, +1), digital feedback signal DIGITAL_FB is incremented by one when second digital signal

DIGITAL_OUT is +1, is unchanged when second digital signal DIGITAL_OUT is 0, and is incremented by one when second digital signal DIGITAL_OUT is -1. Thus, digital summer 406 may, along with delay block 412, serve as part of an integration/accumulation loop such that digital feedback signal DIGITAL_FB maintains a running value that approximates a current value of first digital signal DIGITAL_INT. Thus, reduced quantization level quantizer 404 may generate second digital signal DIGITAL_OUT based on the difference between first digital signal DIGITAL_INT and the previous value of digital feedback signal DIGITAL_FB. That is, if first digital signal DIGITAL_INT is one or more quantization levels more than digital feedback signal DIGITAL_FB, then reduced quantization level quantizer 404 may generate second digital signal DIGITAL_OUT as +1; if first digital signal DIGITAL_INT is one or more quantization levels less than digital feedback signal DIGITAL_FB, then reduced quantization level quantizer 404 may generate second digital signal DIGITAL_OUT as -1; and otherwise, reduced quantization level quantizer 404 may generate second digital signal DIGITAL_OUT as 0.

A receiver of digital signal DIGITAL_OUT (e.g., digital audio processor 109), may receive the digital signal DIGITAL_OUT and reconstruct a digital signal with the same number of quantization levels as first digital signal DIGITAL_INT by integrating values of digital output signal DIGITAL_OUT.

In some embodiments, the various quantization levels of the second digital signal DIGITAL_OUT may be represented by corresponding digital codes. For example, when the second digital signal has three possible quantization levels (-1, 0, +1), then each quantization level may be represented by a corresponding two-bit digital code. In such embodiments, remaining unused codes may be employed to represent and communicate a control signal associated with system 100 (e.g., a signal gain associated with the digital microphone system, a direct current bias associated with the digital microphone system, etc.).

In other embodiments, quantization levels of the second digital signal DIGITAL_OUT may not be represented by a digital code, but may instead be represented by a transition or lack of transition of second digital signal DIGITAL_OUT. For example, in embodiments in which the second digital signal DIGITAL_OUT has three

quantization levels, an example encoding between signal transitions and quantization levels may be illustrated in FIGURE 5. As shown in graphs 502 and 504, to represent 0, second digital signal DIGITAL_OUT may not transition during a sampling period T. As shown in graphs 506 and 508, to represent +1, second digital signal DIGITAL_OUT may transition from low to high during a sampling period T. As shown in graphs 510 and 512, represent -1, second digital signal DIGITAL_OUT may transition from high to low during a sampling period T.

In addition to permitting a multiple-bit signal to be carried on a single wire, the encoding scheme shown in FIGURE 5 may provide for reduction in power in transmitting second digital signal DIGITAL_OUT. Often, a significant portion of power loss in signal transmission on a digital bus occurs as a result of transitions of the digital signal. However, in the case of the encoding scheme shown in FIGURE 5, no transitions are present when second digital signal DIGITAL_OUT is equal to 0, and thus transmission of such value results in little or no power loss. In such embodiments, power loss may also be reduced by suppression transmission of control data when there is no transition in the data of second digital signal DIGITAL_OUT. To illustrate, in some implementations, second digital signal DIGITAL_OUT may be carried on a communication bus which is also used to carry control signals. Thus, second digital signal DIGITAL_OUT may be interleaved with one or more control signals. To prevent transitions occurring from the control signals, communication of control signals may be suppressed when the second digital signal is 0, and thus not transitioning.

This disclosure encompasses all changes, substitutions, variations, alterations, and modifications to the example embodiments herein that a person having ordinary skill in the art would comprehend. Similarly, where appropriate, the appended claims encompass all changes, substitutions, variations, alterations, and modifications to the example embodiments herein that a person having ordinary skill in the art would comprehend. Moreover, reference in the appended claims to an apparatus or system or a component of an apparatus or system being adapted to, arranged to, capable of, configured to, enabled to, operable to, or operative to perform a particular function encompasses that apparatus, system, or component, whether or not it or that particular function is activated, turned on,

or unlocked, as long as that apparatus, system, or component is so adapted, arranged, capable, configured, enabled, operable, or operative.

All examples and conditional language recited herein are intended for pedagogical objects to aid the reader in understanding the disclosure and the concepts contributed by the inventor to furthering the art, and are construed as being without limitation to such specifically recited examples and conditions. Although embodiments of the present disclosure have been described in detail, it should be understood that various changes, substitutions, and alterations could be made hereto without departing from the spirit and scope of the disclosure.

WHAT IS CLAIMED IS:

1. A digital microphone system comprising:
a microphone transducer configured to generate an analog input signal indicative
5 of audio sounds incident upon the microphone transducer;
a digital processing system configured to:
convert the analog input signal into a first digital signal having a plurality
of quantization levels; and
in the digital domain, process the first digital signal to compress the first
10 digital signal into a second digital signal having fewer quantization levels than
that of the first digital signal.
2. The system of Claim 1, wherein the microphone transducer and the digital
processing system are formed on a single substrate.
15
3. The system of Claim 1, wherein the microphone transducer and the digital
processing system are formed on different substrates packaged within the same integrated
circuit package.
- 20 4. The system of Claim 1, wherein the microphone transducer comprises a
microelectromechanical systems microphone.
5. The system of Claim 1, wherein:
each quantization level of the first digital signal is represented by an N-bit digital
25 code, wherein N is a positive integer; and
each quantization level of the second digital signal is represented by an M-bit
digital code, wherein M is a positive integer less than N

6. The system of Claim 5, wherein:

the number of possible M-bit digital codes is more than the number of quantization levels of the second digital signal; and

5 one or more M-bit digital codes not corresponding to quantization levels represent a control signal associated with the digital microphone system.

7. The system of Claim 6, wherein the control signal represents a signal gain associated with the digital microphone system.

10 8. The system of Claim 6, wherein the control signal represents a direct current bias associated with the digital microphone system.

9. The system of Claim 5, wherein:

the second digital signal has three quantization levels, including:

15 a first quantization level that corresponds to an increase in the first digital signal equal to one quantization level of the first digital signal;

a second quantization level that corresponds to no change of the quantization level of the first digital signal; and

20 a third quantization level that corresponds to a decrease in the first digital signal equal to one quantization level of the first digital signal; and

the quantization level of the second digital signal is represented by a transition or lack of transition of the second digital signal.

25 10. The system of Claim 9, wherein the digital processing system is further configured to:

communicate the second digital signal on a bus interleaved with one or more control signals; and

suppress communication of control signals when the second digital signal is of the second quantization level.

30

11. A system comprising:

a microphone transducer configured to generate an analog input signal indicative of audio sounds incident upon the microphone transducer; and

5 a digital processing system configured to convert the analog input signal into a digital signal having a plurality of quantization levels, such that each quantization level is represented by one or more transitions or one or more absences of transitions of one or more bits of the digital signal.

12. The system of Claim 11, wherein:

10 the digital signal has three quantization levels, including:

a first quantization level that corresponds to an increase in the analog input signal;

a second quantization level that corresponds to no change of the analog input signal; and

15 a third quantization level that corresponds to a decrease in the analog input signal; and

the quantization level of the digital signal is represented by a transition or lack of transition of the digital signal.

20 13. The system of Claim 12, wherein the digital processing system is further configured to:

communicate the digital signal on a bus interleaved with one or more control signals; and

25 suppress communication of control signals when the digital signal is of the second quantization level.

14. A method comprising:

generating an analog input signal indicative of audio sounds incident upon a microphone transducer;

30 converting the analog input signal into a first digital signal having a plurality of quantization levels; and

in the digital domain, processing the first digital signal to compress the first digital signal into a second digital signal having fewer quantization levels than that of the first digital signal.

5 15. The method of Claim 14, wherein the microphone transducer comprises a microelectromechanical systems microphone.

 16. The method of Claim 14, wherein:
 each quantization level of the first digital signal is represented by an N-bit digital
10 code, wherein N is a positive integer; and
 each quantization level of the second digital signal is represented by an M-bit
 digital code, wherein M is a positive integer less than N.

 17. The method of Claim 16, wherein:
15 the number of possible M-bit digital codes is more than the number of
 quantization levels of the second digital signal; and
 one or more M-bit digital codes not corresponding to quantization levels represent
 a control signal associated with the digital microphone system.

20 18. The method of Claim 17, wherein the control signal represents a signal
 gain associated with the digital microphone system.

 19. The method of Claim 19, wherein the control signal represents a direct
 current bias associated with the digital microphone system.

25 20. The method of Claim 16, wherein:
 the second digital signal has three quantization levels, including:
 a first quantization level that corresponds to an increase in the first digital
 signal equal to one quantization level of the first digital signal;
30 a second quantization level that corresponds to no change of the
 quantization level of the first digital signal; and

a third quantization level that corresponds to a decrease in the first digital signal equal to one quantization level of the first digital signal; and the quantization level of the second digital signal is represented by a transition or lack of transition of the second digital signal.

5

21. The method of Claim 20, further comprising:
communicating the second digital signal on a bus interleaved with one or more control signals; and
suppressing communication of control signals when the second digital signal is of the second quantization level.

10

22. A method comprising:
generating an analog input signal indicative of audio sounds incident upon a microphone transducer; and
converting the analog input signal into a digital signal having a plurality of quantization levels, such that each quantization level is represented by one or more transitions or one or more absences of transitions of one or more bits of the digital signal.

15

23. The method of Claim 22, wherein:
the digital signal has three quantization levels, including:
a first quantization level that corresponds to an increase in the analog input signal;
a second quantization level that corresponds to no change of the analog input signal; and
a third quantization level that corresponds to a decrease in the analog input signal; and
the quantization level of the digital signal is represented by a transition or lack of transition of the digital signal.

20

25

24. The method of Claim 23, further comprising:

30

communicating the digital signal on a bus interleaved with one or more control signals; and

suppressing communication of control signals when the digital signal is of the second quantization level.

5

25. An integrated circuit comprising:

a microphone input configured to receive an analog input signal indicative of audio sounds incident upon a microphone transducer; and

a processing circuit configured to:

10

convert the analog input signal into a first digital signal having a plurality of quantization levels; and

in the digital domain, process the first digital signal to compress the first digital signal into a second digital signal having fewer quantization levels than that of the first digital signal.

15

26. The integrated circuit of Claim 1, wherein the microphone transducer comprises a microelectromechanical systems microphone.

27. The integrated circuit of Claim 1, wherein:

20

each quantization level of the first digital signal is represented by an N-bit digital code, wherein N is a positive integer; and

each quantization level of the second digital signal is represented by an M-bit digital code, wherein M is a positive integer less than N

25

28. The integrated circuit of Claim 27, wherein:

the number of possible M-bit digital codes is more than the number of quantization levels of the second digital signal; and

one or more M-bit digital codes not corresponding to quantization levels represent a control signal associated with the digital microphone system.

30

29. The integrated circuit of Claim 28, wherein the control signal represents a signal gain associated with the digital microphone system.

30. The integrated circuit of Claim 28, wherein the control signal represents a
5 direct current bias associated with the digital microphone system.

31. The integrated circuit of Claim 27, wherein:
the second digital signal has three quantization levels, including:
a first quantization level that corresponds to an increase in the first digital
10 signal equal to one quantization level of the first digital signal;
a second quantization level that corresponds to no change of the
quantization level of the first digital signal; and
a third quantization level that corresponds to a decrease in the first digital
signal equal to one quantization level of the first digital signal; and
15 the quantization level of the second digital signal is represented by a transition or
lack of transition of the second digital signal.

32. The integrated circuit of Claim 31, wherein the processing circuit is further
configured to:
20 communicate the second digital signal on a bus interleaved with one or more
control signals; and
suppress communication of control signals when the second digital signal is of the
second quantization level.

25 33. An integrated circuit comprising:
a microphone input configured to receive an analog input signal indicative of
audio sounds incident upon a microphone transducer; and
a processing circuit configured to convert the analog input signal into a digital
signal having a plurality of quantization levels, such that each quantization level is
30 represented by one or more transitions or one or more absences of transitions of one or
more bits of the digital signal.

34. The system of Claim 33, wherein:
the digital signal has three quantization levels, including:
a first quantization level that corresponds to an increase in the analog input
5 signal;
a second quantization level that corresponds to no change of the analog
input signal; and
a third quantization level that corresponds to a decrease in the analog input
signal; and
10 the quantization level of the digital signal is represented by a transition or lack of
transition of the digital signal.

35. The system of Claim 34, wherein the processing circuit is further
configured to:
15 communicate the digital signal on a bus interleaved with one or more control
signals; and
suppress communication of control signals when the digital signal is of the second
quantization level.

1/2

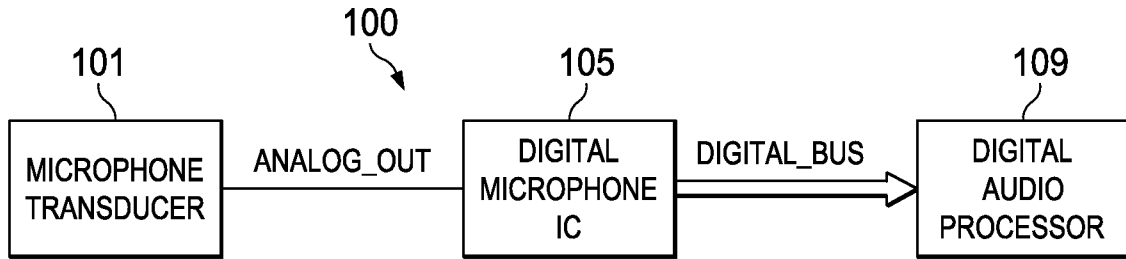

FIG. 1

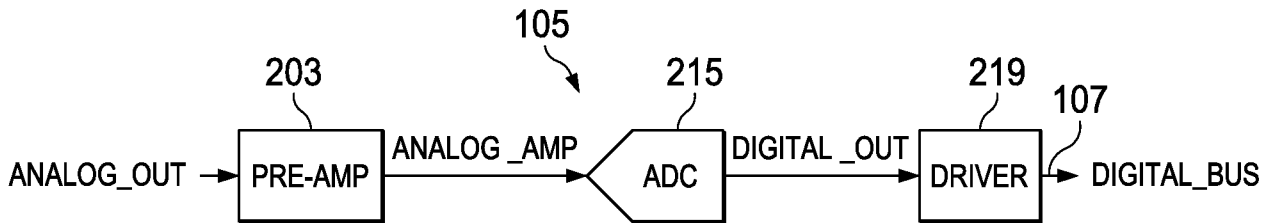

FIG. 2

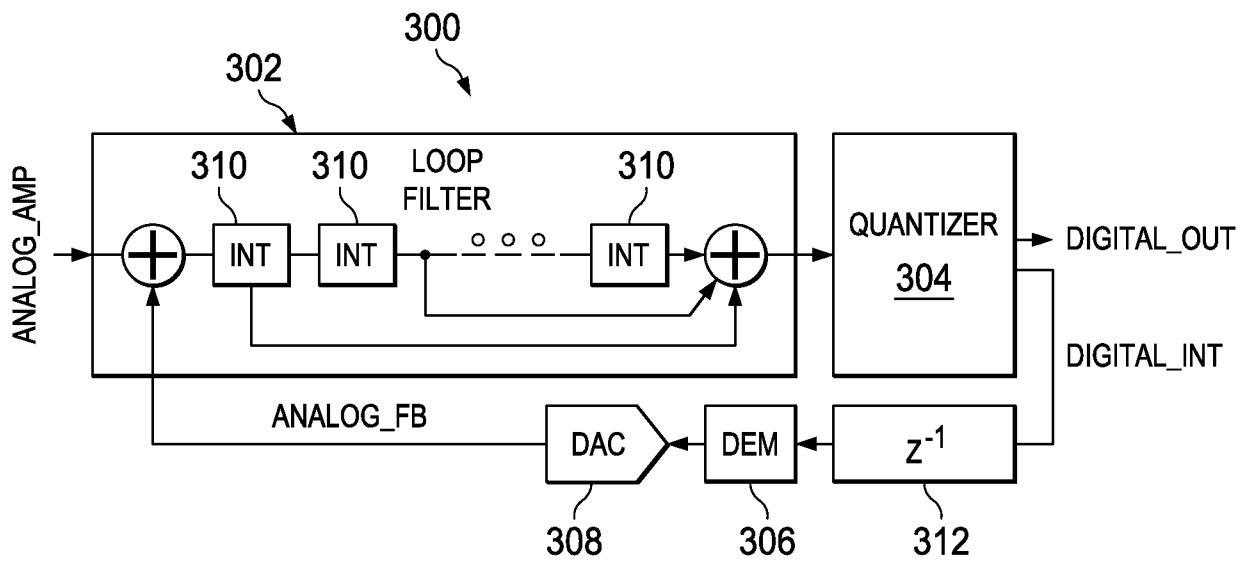

FIG. 3

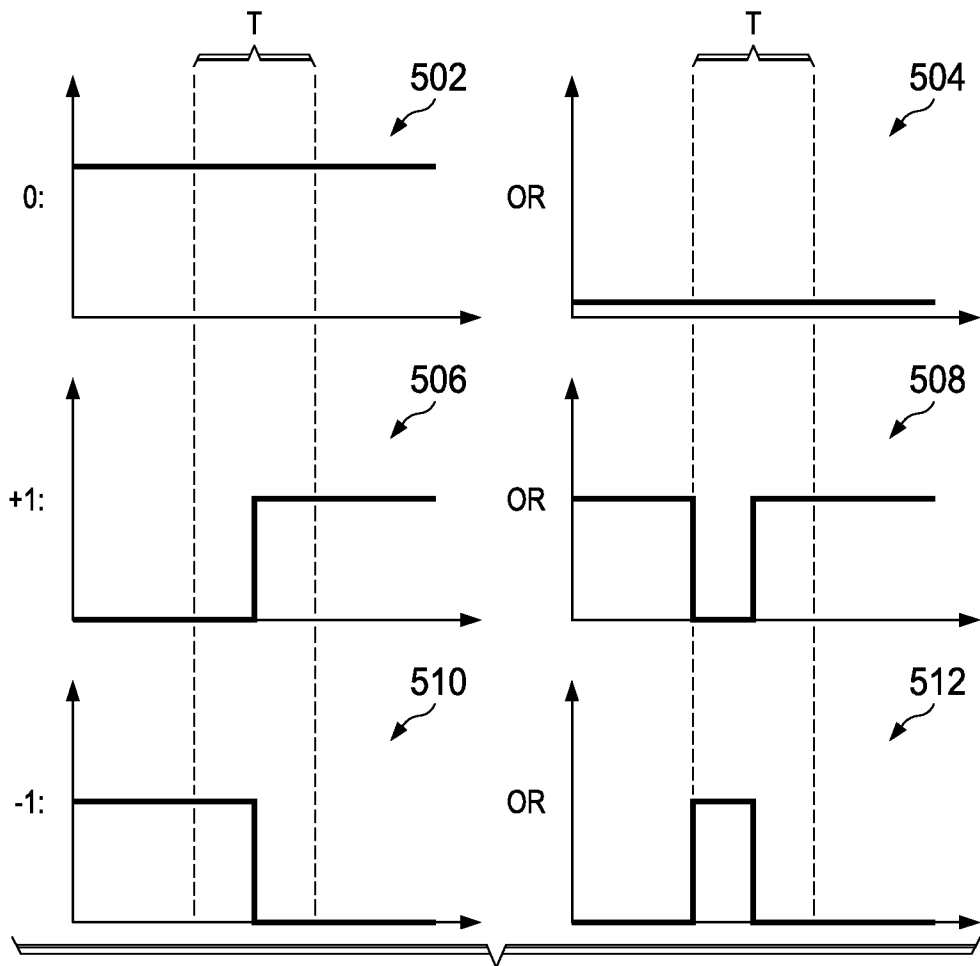
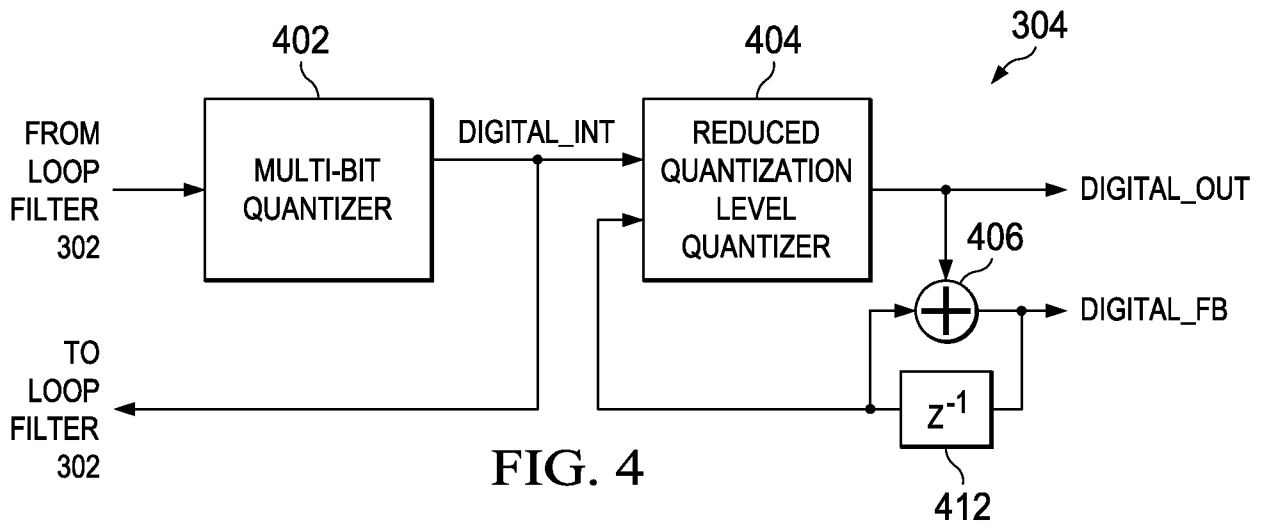

FIG. 5