

TX 350-6.5

Feb. 14, 1939.

E. C. MEYER

2,147,452

TELEVISION APPARATUS

Filed Oct. 22, 1934

Fig. 1.

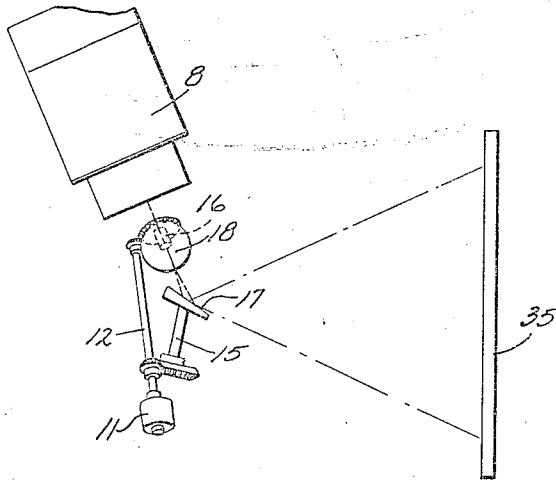

Fig. 2.

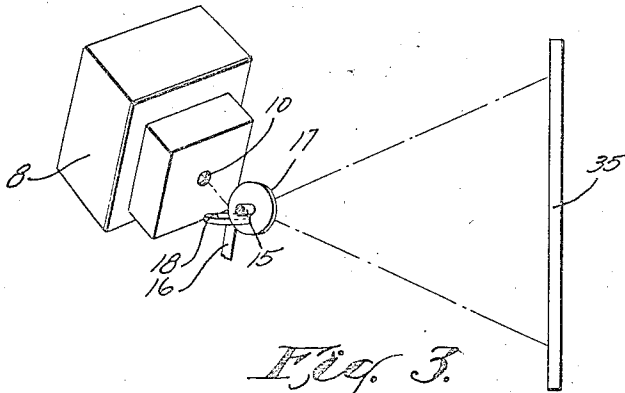

Fig. 4.

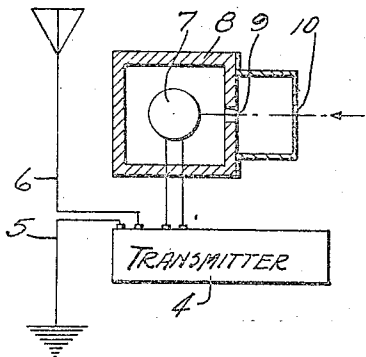

Fig. 3.

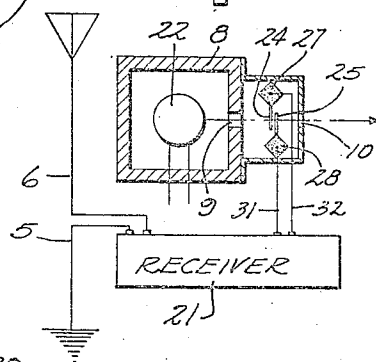
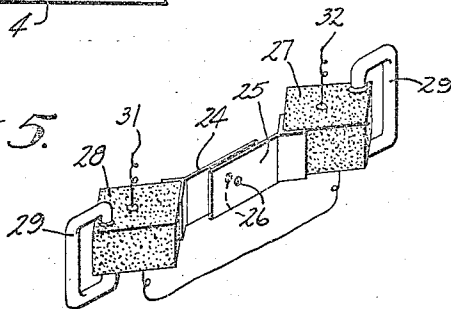

Fig. 5.



INVENTOR  
*Eugene Carl Meyer*  
 BY  
*Wheeler, Wheeler, & Wheeler*  
 ATTORNEYS

## UNITED STATES PATENT OFFICE

2,147,452

## TELEVISION APPARATUS

Eugene Carl Meyer, Milwaukee, Wis., assignor to  
Richard W. Werner, Milwaukee, Wis.

Application October 22, 1934, Serial No. 749,393

3 Claims. (Cl. 178—7.3)

This invention relates to improvements in television apparatus.

It is the primary object of the invention to provide novel and improved scanning means and novel and improved light controlling means. The scanning means is used both in the "pick-up" device and in the reproducing device. The improvements contemplated by this invention are such as greatly to simplify and reduce the expense of television apparatus, whether such apparatus is used in conjunction with line communication or radio.

The illustration of the invention in the drawing is purely diagrammatic.

Figures 1 and 2 are plan and side views, respectively, showing the reproduction device used at the receiving end.

Figure 3 is a view of the reproduction chamber and shutter chamber in section, indicating diagrammatically its operating connections.

Figure 4 is a view of the photoelectric chamber illustrating diagrammatically its connections.

Figure 5 is a detail view showing, in perspective, the mechanism which modulates the intensity of the light in the reproducing system, the hole in the shutter being disproportionately enlarged.

Like parts are identified by the same reference characters throughout the several views.

It being broadly immaterial how the television signals are transmitted, I have chosen to illustrate the invention from the standpoint of radio transmission. A conventional radio transmitting apparatus is shown at 4, preferably having a ground connection at 5 and an antenna connection at 6. The carrier wave produced therein in the usual manner is modulated by the current impulses from a photoelectric cell 7, which is almost completely enclosed in a cabinet 8 and exposed only to such light as enters the cabinet through the aligned orifices 9 and 10, the relative size of which is necessarily greatly exaggerated in the drawing. The area of the light beam admitted to the photoelectric cell 7 will be no greater than the theoretical area known optically as "the circle of confusion". In other words, the light beam will be so small in cross section as to represent virtually the light from a single point from the object. This light beam is taken successively from different points of the object until the whole area thereof is covered, and the coverage must be repeated sufficiently often so that the retentiveness to human vision will enable the light from one point to persist until all points have been covered.

In motion picture photography it has been found that 16 complete images per second give the illusion of continuous motion, and consequently the present apparatus may be designed to scan all portions of the surface of the object at least 16 times each second. The principle of scanning is well known as applied to television, but the particular means herein disclosed is believed to be novel.

The motor 11, having an armature shaft 12 turning at a given speed, is used to drive shafts 15 and 16 at mutually different speeds, as determined by the gearing or other motion transmitting connections through which the shafts 15 and 16 are operated from shaft 12. The exact difference in the rate of rotation is not important. It will ordinarily be found, however, that the best results will be had when one shaft rotates almost as fast as the other.

Shafts 15 and 16 carry mirrors 17 and 18, respectively, each mirror being in a plane not quite 90 degrees with reference to the shaft upon which the mirror is mounted. If a beam of light were to strike either mirror parallel to the shaft upon which the mirror is mounted, the light would be reflected upon a conical path and would describe a circle on a screen at right angles to the shaft axis. The shafts are so fixed, however, that the light beams which they reflect have angles of incidence and reflection which are extremely acute. Thus, the reflected image will necessarily comprise an extremely flat ellipse, having one elongated diameter and one diameter so short as to be negligible. The shafts are further offset angularly with reference to each other about the axis of the transmitted beam so that the elongated diameter of the ellipse produced by one mirror is approximately at right angles to the elongated diameter of the ellipse produced by the other mirror. The resultant effect on a beam of light reflected by both mirrors will give the light sufficient movement in two different directions to enable it to cover an entire screen during the continued rotation of the mirrors.

The mirror system is so organized that only one beam of light received from the object 20 can at any given time be reflected from the mirror system through the orifices 10 and 9 of case 8 to reach the photoelectric cell. The beam received by such orifices is only such as has been reflected by both mirrors, and the point on the object from which the beam is received is constantly shifting in the predetermined path, the form and direction of which will depend upon the exact relative rates of rotation of the two

shafts 15 and 16 and the relation of the shafts with respect to the direct path between the object and the orifices 9 and 10.

In general, however, within a wide range of relative R. P. M. of shafts 15 and 16, the scanning path will represent what might be called a plane projection of a deformed or flattened helix moving progressively across the object. The difference in rate of relative rotation of shafts 15 and 16 will represent the pitch of the helix, and it should be so small that the pitch or advance of the flattened helical path of the imaginary beam of light described by mirrors 17 and 18 will represent approximately the width of the beam itself so that the beam will cover all portions of the surface area during each cycle.

By reason of the described arrangement the photoelectric cell 7 will receive light of varying intensity according as the scanning operation proceeds and the beam comes at the moment from a light or other portion of the surface of the object. The photoelectric cell operates in the conventional manner to deliver current according to the intensity of the light beam falling thereon, and this current is used to modulate the carrier wave broadcast by transmitter 4 and antenna 6.

The modulated carrier wave is received and reproduced in the form of an image by means of the apparatus shown in Figures 2 and 3. A radio receiver 21 of generally conventional design has an antenna connection 6 and a ground connection 5. Therein, apart from the usual amplifying mechanism, there is a means for employing the amplitude of modulation of the carrier wave to vary the intensity of light given off from a constant source, such as the lamp 22.

The means by which this is accomplished comprises a pair of overlapping shutters 24 and 25 having small openings 26 which are normally staggered but may be placed in registry by the amplitude of the vibratory movement of the shutters. To place the shutters in high frequency vibration at varying amplitudes, I preferably employ the so-called piezo-electric crystal effect referred to, for example in Patent No. 1,450,246 and elsewhere. A pair of crystals 27 and 28 are mounted on supports 29, and to them are connected the respective shutters 24 and 25 in overlapping relation, as shown in Figure 3. The mounting is preferably remote from the shutters so that the full expansion of the crystal is made available for the reciprocation of the shutters. The crystals may be connected either in parallel or series. I have illustrated a series connection by means of a conductor 30. Conductors 31 and 32 lead to the amplifier or receiver to receive the output thereof which is at a frequency which will cause the crystals to vibrate, the amplitude of the vibration being dependent upon the intensity of the inciting signal as received from the transmitting station.

The light source 22, which is of constant brilliance, is enclosed in a case 3 like that previously described, said casing having aligned orifices 9 and 10 between which the shutters 24 and 25 are interposed.

When the shutters are overlapped as shown in Figure 5, the apertures 26 thereof will almost be out of registry, but as the crystals expand the overlap of shutters 24 and 25 will be increased until near or at the full amplitude the orifices 26 will register with each other and with the orifices 9 and 10 of the cabinet. Obviously the beam of light passing from the source 22 to the

orifices 9 and 10 of the reproducing cabinet will vary in intensity according to the overlap of orifices 26 of the shutters, and since such overlap will depend on the amplitude of crystal vibration, and this in turn upon the intensity of the received signal, it will be obvious that I have provided means whereby fluctuations of current in the photoelectric cell at the sending station occasioned by fluctuations of light received by said cell from the object, will be enabled to reproduce at the transmitting station similar fluctuations in the intensity of the emitted light.

The light emitted from the source 22 under the control of shutters 24 and 25 passes the mirror system of a scanning device identical with that already described. The motors 11 at the sending and receiving station are preferably synchronous motors, operating not only at the same R. P. M. but in exact unison so that the cycles of scanning operation of the mirror systems in the two stations are identical. When this condition is reached a beam of light from any given point of the object must necessarily find its counterpart in a beam of light from the source 22 delivered to exactly the same corresponding point on the screen 35 on which the image is reproduced.

As the object is scanned by the mechanism shown in Figure 4, so the said screen is scanned in Figures 1 and 2. For each given point of the object which is thus scanned there is a given intensity of light affecting the photoelectric cell 7, and the effect of such cell produces a corresponding relative intensity of the light beam emitted from the source 22, the control of said beam being accomplished by the amplitude of vibration of the piezo crystals which control the shutters 24 and 25. Thus, the image reproduces the object not only in faithful detail as to the point from which the light originates, but also in faithful detail as to the intensity of light from each point.

The mirror system herein disclosed provides a means for scanning a large surface with tremendous rapidity, since there are no reciprocating parts employed in the scanning device, and no shutters are necessary. The transmitting mechanism is receiving one continuous beam of light varying in intensity according to the point of the object which is its source. The reproducing device is emitting a similar continuous stream of light going to a corresponding point on the screen and having an identical variation in intensity. The shutters 24 and 25 at no time wholly interrupt the light from the source 22 unless there is a total interruption of light at the object. Thus, the device produces a brilliant illumination.

The use of piezo crystals as a means of controlling the intensity of the light from source 22 gives a reproducing mechanism which is much more sensitive than it is possible to find in any apparatus which attempts to vary the intensity of the source. No lamp is capable of responding as accurately or as fast as do the piezo crystals respond in amplitude of vibration to the intensity of the received signal.

I claim:

1. In television apparatus, a scanning device comprising a pair of coating mirrors arranged 70 successively in the path of a beam of light, shafts supporting each of said mirrors and connected with their respective mirrors in positions other than normal to the reflecting surfaces thereof, and means for driving said shafts at different 75

rates of speed, said shafts being offset angularly for approximately ninety degrees about the axis of the path of said beam of light.

5 2. In television apparatus or the like, the combination with means defining the direction of a  
10 beam of light, of a succession of mirrors disposed in the path of said beam in positions such that said beam is incident upon said mirrors  
15 successively at extremely acute angles, means for operating said mirrors at different rates to vary the angle of incidence of the beam thereon within an extremely limited range, and supports for said mirrors displaced angularly approximately ninety degrees about the axis of said  
beam, whereby the varying angle of incidence and reflection of said beam on successive mirrors will effect a movement of one end of said beam in each of several directions approximately at right angles to each other.

3. In a device of the character described, the combination with means for defining a given path for a beam of light at one end of said beam, of a set of substantially planiform mirrors mounted for rotation about axes deviating from  
5 normal with reference to the surfaces of the respective mirrors and angularly offset approximately ninety degrees about the axis of said  
10 beam, said mirrors being arranged in the path of said beam to reflect said beam from one mirror to the other successively at slight angles of incidence and reflection, whereby the beam reflected by each mirror describes a flat ellipse, and means for rotating said mirrors at differing  
15 rates of speed whereby their composite effect on said beam of light involves a scanning movement of said beam in each of two directions approximately at right angles to each other.

EUGENE CARL MEYER.