

Gross & Hall,

Permutation Lock.

No. 107,174.

Patented Sep. 6. 1870.

Fig. 1.

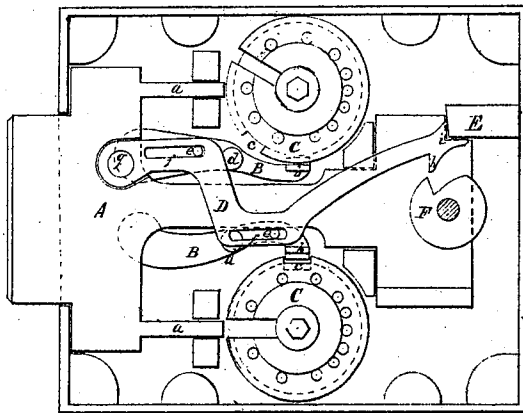

Fig. 2.

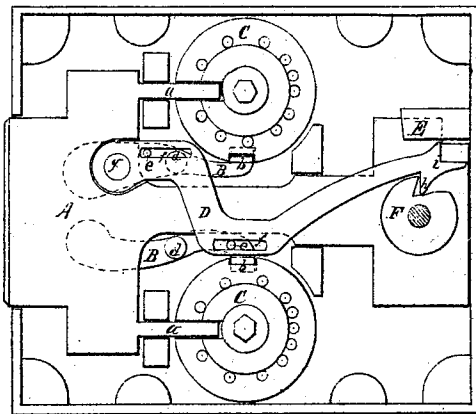
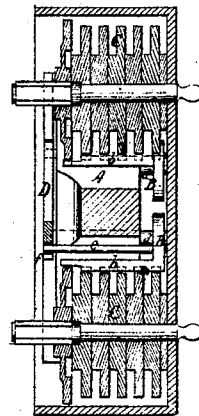

Fig. 3.



Witnesses: C. W. Cole  
A. L. Fisher

Inventors:  
Henry Gross  
Joseph L. Hall

# United States Patent Office.

HENRY GROSS AND JOSEPH L. HALL, OF CINCINNATI, OHIO.

Letters Patent No. 107,174, dated September 6, 1870.

## IMPROVEMENT IN PERMUTATION LOCKS.

The Schedule referred to in these Letters Patent and making part of the same.

We, HENRY GROSS and JOSEPH L. HALL, of Cincinnati, in the county of Hamilton and State of Ohio, have invented certain Improvements in Permutation Locks, of which the following is a specification.

Our invention relates to permutation locks; and

It consists in a novel arrangement of the parts whereby burglars and others are prevented from "feeling" the tumblers by means of the locking-bolt, when the lock is closed, as hereinafter more fully explained.

Figure 1 represents a plan of the interior of a lock embodying our invention, showing one series of tumblers in position to prevent the retraction of the bolt.

Figure 2 is a plan of the same, showing the relative positions of the various parts of the lock when the bolt is retracted.

Figure 3 is a cross-section of the lock, taken through the tumblers.

In the double-tumbled lock herein represented, the bolt A is provided with two sliding bars, *a a*, adapted in form to fill the slots in the tumblers when the bolt is retracted.

The vibrating angle-bars B B are pivoted to the case of the lock, one on each side of the neck of the bolt.

The ends of the vibrating-bars are armed with bars, *b b*, of a form adapting them to fit closely the notches *c c* in the tumblers C C at the time that the bolt is or may be retracted.

Between the pivots *d d* and the ends of the vibrating-bars are located the pins *e e*, which engage the check-bar D, and are moved freely in the slots *f f* of the said check-bar when the bolt is operated.

One end of the bar D is pivoted to the bolt at *g*.

The free end is constructed with a square recess, *i*, in its upper face, to engage with the square pillar E when the bolt is out and the bars of the vibrating-bars are not entered in their recesses in the tumblers.

Near the free end of the check-bar D, and projecting down from its bottom face, is the finger *h*, which engages the wheel F attached to the handle of the lock for throwing the bolt.

The check-bar D, being hinged to the bolt of the lock, and, at the same time, in contact at its free end with the pillar E, effectually prevents the retraction of the bolt A when the combination to which the tumblers are arranged does not prevent the free entrance of the bars *b b* into the notches in the faces of the tumblers, as shown in fig. 1. In this case the ends of the sliding-bars *a a* attached to the bolt A do not rest upon the faces of the tumblers, and, consequently, no manipulation of the tumblers or bolt can be made by the use of any tools, machinery, or instrument of whatever kind in the hands of an expert or burglar; nor can the combination be arrived at by degrees, and the bolt ultimately retracted. Only to one familiar with the formula on which the safe or receptacle is to be unlocked can the slots in the tumblers be arranged to receive the bars *b b* of the vibrating-bars B B, and the check-bar D be at liberty to fall sufficiently, (being otherwise held up by the pins *e e*), that the bolt may be retracted, the bars *a a* thereof entering freely the slots in the tumblers.

What we claim as our invention is—

The combination of the bolt A, provided with the dogs *a*, and having the check-bolt D pivoted thereto, with the two independent nests of tumblers C, vibrating-bars B, and the independently-operating cam E, all constructed and arranged to operate substantially as set forth.

HENRY GROSS.  
JOSEPH L. HALL.

Witnesses:

C. W. COLE,  
C. L. FISHER.