

(12) INTERNATIONAL APPLICATION PUBLISHED UNDER THE PATENT COOPERATION TREATY (PCT)

(19) World Intellectual Property Organization
International Bureau



(43) International Publication Date
8 November 2001 (08.11.2001)

PCT

(10) International Publication Number
WO 01/84493 A1

- (51) International Patent Classification⁷: **G06K 19/077** [FR/FR]; 5, Le Clos, F-91370 Verrières (FR). **CATTE, Etienne** [FR/FR]; 71, rue Buzenval, F-92210 Saint Cloud (FR).
- (21) International Application Number: PCT/IB01/00739
- (22) International Filing Date: 2 May 2001 (02.05.2001)
- (25) Filing Language: English
- (26) Publication Language: English
- (30) Priority Data: 0005621 3 May 2000 (03.05.2000) FR
- (71) Applicant (for all designated States except US): **SCHLUMBERGER SYSTEMES** [FR/FR]; 50, avenue Jean Jaurès, F-92120 Montrouge (FR).
- (72) Inventors; and
- (75) Inventors/Applicants (for US only): **GUION, Christian**
- (74) Common Representative: **SCHLUMBERGER SYSTEMES**; c/o Den Braber, Gérard, 50, avenue Jean Jaurès, B.P. 620-12, F-92542 Montrouge cédex (FR).
- (81) Designated States (national): BR, CN, JP, US.
- (84) Designated States (regional): European patent (AT, BE, CH, CY, DE, DK, ES, FI, FR, GB, GR, IE, IT, LU, MC, NL, PT, SE, TR).
- Published:**
— with international search report

For two-letter codes and other abbreviations, refer to the "Guidance Notes on Codes and Abbreviations" appearing at the beginning of each regular issue of the PCT Gazette.

(54) Title: A CARD COMPRISING ELECTRICAL CONTACTS

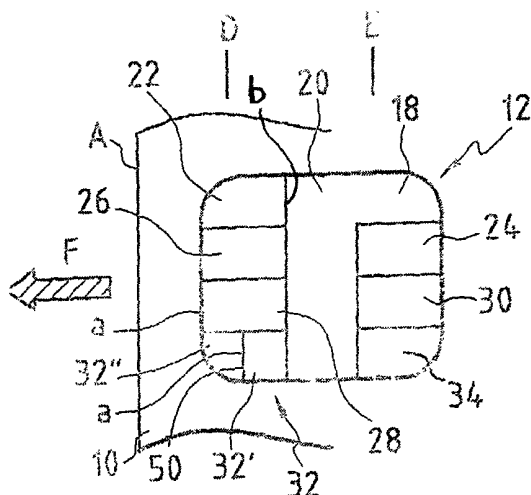

(57) Abstract: A card comprises electrical contacts (18, 22, 32, 34) for communicating in accordance with a universal serial bus standard. The card can be inserted in a card reader having complementary electrical contacts (16). The card has an insertion edge (A) which traverses the complementary electrical contacts (16) when the card is inserted in the card reader in a correct fashion. The card comprises an electrical contact (22) for receiving a power supply voltage which electrical contact (22) is closer to the insertion edge (A) than any electrical contact for communicating data in accordance with the universal serial bus standard (32, 34).

WO 01/84493 A1

A CARD COMPRISING ELECTRICAL CONTACTS

FIELD OF THE INVENTION

The present invention relates to a card comprising
5 electrical contacts for communicating in accordance with
a universal serial bus (USB) standard, for example, the
USB standard version 1.1 of September 23, 1998. Such a
card can be inserted in a card reader having
10 complementary electrical contacts. The card reader may be
part of, for example, a microcomputer.

BACKGROUND OF THE INVENTION

The French patent application published under number
2 783 336 describes a card comprising electrical contacts
15 for communicating in accordance with a universal serial
bus (USB) standard. The card has external electrical
contact areas compatible not only with ISO standard 7816
which defines standard cards, but also with USB standard
version 1.1 of September 23, 1998.

20 A problem encountered is described below with
reference to accompanying Figures 1 and 2.

Figure 1 shows part of a card body 10 made of
plastics material and having an electronics module 12
received therein represented by its external contact
25 areas 14 for providing electrical connections between the
integrated circuit of the electronics module 12 and
contact elements of the connector 16 shown in Figure 2.
As a general rule, the various contacts are constituted
by a single conductive coating made on the contact face
30 of the module and etched so as to define different
external areas. With a standard module, there is a first
area 18 that constitutes the ground contact and that
generally extends into a central zone 20 of the face of
the electronics module, a VCC area 22 for supplying
35 electrical power to the electronics module, a VPP area 24
for applying a write voltage for the memories of the
electronics module, an RST area 26 for resetting

auxiliary circuits of the electronics module to zero, an area 28 for receiving a clock signal CLK, and an I/O area 30 for inputting and outputting data interchanged between the electronics module of the card and the card reader.

5 Two areas 32 and 34 remain available. For a card that complies simultaneously both with ISO standard 7816 and with the USB standard, the external areas 32 and 34, conventionally referred to as D+ and D-, serve as serial data inputs for providing a higher rate of information

10 interchange between the card and the reader. The areas 18 to 34 are distributed in two rows that extend perpendicularly to the direction in which the card is inserted into the reader.

Figure 2 shows the connector 16 of the card reader which essentially comprises a frame 36 having two parallel series of resilient contacts 38 and 40 fixed thereon for coming into electrical contact with respective ones of the external areas. The various resilient contacts 38 and 40 are connected to a processor circuit 42 of the reader. In Figure 2, arrow F shows the direction in which the card C is inserted into the reader, and the term "insertion edge" is used to designate the edge A of the card body 10 adjacent to which the electronics module 12 is located.

25 It will be understood that given the geometrical disposition of the external areas which are in alignment via their edges and of the resilient contacts 38 and 40 of the reader which are also in alignment, connection between the resilient contacts of the reader and the external contact areas of the card takes place

30 simultaneously for all eight external areas of the electrical contact.

For standard cards complying with ISO standard 7816, this situation does not present any drawback since the connector remains unpowered until the card has been fully

35 inserted. In contrast, with cards that comply with the USB standard, this situation is unacceptable, and in

particular it is not acceptable that the electrical power supply voltage for the circuits of the electronics module as applied between external areas 18 and 22 might be applied after information signals are applied to the areas 32 and 34. The standard requires that the element plugged into the USB connector must be capable of being plugged in while the connector is powered. In addition, the standard specifies that power supply and ground must necessarily be connected before all of the other contacts.

SUMMARY OF THE INVENTION

An object of the present invention is to allow versatility of use.

To this end, a card comprising electrical contacts for communicating in accordance with a universal serial bus standard, which card can be inserted in a card reader having complementary electrical contacts, the card having an insertion edge which traverses the complementary electrical contacts when the card is inserted in the card reader in a correct fashion, is characterized in that the card comprises an electrical contact for receiving a power supply voltage which electrical contact is closer to the insertion edge than any electrical contact for communicating data in accordance with the universal serial bus standard.

Let it be assumed that a card in accordance with the invention, is inserted in a standard type card reader as shown in Figure 2. Such a card has a power supply contact that is closer to the insertion edge than any USB-data contact. Consequently, the power supply contacts of the card come into contact with the complementary power supply contacts of the reader before the USB data contacts of the card come into contact with the complementary USB-data contacts of the reader. The USB standard is thus complied with notwithstanding the use of a standard type card reader which otherwise could have

resulted in a malfunctioning. Consequently, the invention allows a standard type card reader to effect USB data communication and, therefore, the invention allows versatility in use.

5 These and other characteristics and advantages of the invention will appear better on reading the following description of a plurality of embodiments of the invention given as non-limiting examples.

10 BRIEF DESCRIPTION OF THE DRAWINGS

Figure 1, described above, shows the contact face of a standard electronics module;

15 Figure 2, described above, shows a conventional embodiment of a connector for a device for processing an electronic memory card;

Figure 3 shows a first embodiment of the contact areas of the electronics module for a card in accordance with the invention;

20 Figure 4 shows a variant embodiment of the electronics module;

Figure 5 shows a third embodiment of the external contact areas of an electronic memory card; and

Figure 6 shows a fourth embodiment of the external areas in accordance with the invention.

25

DETAILED DESCRIPTION

The first embodiment of the invention is described with reference initially to Figure 3. In this figure, there can be seen the card body 10 with its electronics module 12 and its external electrical contact areas 30 referenced 18 to 34. Each external area has the same function as described above with reference to Figure 1. These areas are disposed in rows D and E which extend perpendicularly to the insertion direction F of the card. For each external area, index a identifies the edge of the area which is closest to the insertion edge A, while index b indicates its edge which is furthest away

therefrom. For contact areas 22, 26, and 28, the a and the b edges are all in alignment. In contrast, for the contact 32 corresponding to the D+ input, the a edge referenced 32a is further away from the insertion edge A of the card body than are the other a edges of the areas in the row D. It will thus be understood that while the card C is being inserted into the reader having the connector 16, contact 32 is connected to spring elements 40 and then 38 after contact has been made with the external area 22 for supplying voltage to the electronics module. This ensures that the conditions required by the USB standard are satisfied.

More specifically, it suffices for the metallization forming the contact 32 of Figure 1 to be provided with a line of etching 50 that marks the boundary between a conductive zone 32' connected to the terminals of the electronics module, and a zone 32" that is left floating.

In the embodiment of Figure 4, the contact areas 32 and 34 both have an a edge offset relative to the insertion edge A of the card C. There are thus two active zones 32' and 34' connected to terminals of the electronics module and two floating zones 32" and 34".

It is important to emphasize that this solution makes it possible to achieve the desired characteristics while requiring no modification to the card reader and requiring very little modification in the manufacture of the electronics module, the modification being restricted to the lines of etching 50 and 52 that mark the boundaries between the contact areas corresponding to floating zones and the zones that are connected to the electronics module.

The embodiment of Figure 5 is based on the embodiment of Figure 3. This figure shows the external contact 32 constituted with its floating zone 32" and its active zone 32'. In this embodiment, additional dispositions are provided to prevent a short circuit occurring between contact springs 38 or 40 of the

connector in the card reader during insertion of the card into the reader due to the presence of the intermediate conductive zone 20. To obtain these results, the external area 32 has a second edge b referenced 32b which penetrates into the intermediate zone 20. This extension of the edge b can be obtained by etching 54 formed in the intermediate zone so as to define an extension 32'' of the area 32'. In similar manner, contact area 18 corresponding to ground can have a first edge a, i.e. the edge referenced 18a, which penetrates into the intermediate zone 20, thereby defining an extension 18'' of the area 18 which is defined in this example by etching 56. In addition, relative to the insertion direction F of the card, the second edge 32b is further away from the edge A of the card body than is the first edge 18a of the area 18. Thus, in a direction orthogonal to the insertion direction of the card, overlap e is established between the extensions 32'' and 18'', thus avoiding any risk of a short circuit being established between the spring contacts 38 or 40 of the card reader corresponding to the contact areas 18 and 32.

In the embodiment shown in Figure 6, the same object is achieved as follows: in the intermediate zone 20, floating zones of metallization 60 and 62 are defined in register with the areas 18 & 22 and 32 & 34, which floating areas are separated from the external ground area 18 by lines of etching 64 and 66. The metallization zones 60 and 62 are not electrically connected to any terminal of the semiconductor chip of the electronics module.

The embodiments described hereinbefore with reference to the drawings illustrate the following first set of basic characteristics. A card comprises electrical contacts (18, 22, 32, 34) for communicating in accordance with a universal serial bus standard. The card can be inserted in a card reader having complementary electrical contacts (16). The card has an insertion edge (A) which

traverses the complementary electrical contacts (16) when the card is inserted in the card reader in a correct fashion. The card comprises an electrical contact (22) for receiving a power supply voltage which electrical contact (22) is closer to the insertion edge (A) than any electrical contact for communicating data in accordance with the universal serial bus standard (32, 34).

The embodiments described hereinbefore also illustrate the following second set of basic characteristics. A card comprises a first and a second row of electrical contact areas (D, E). The first row (D) comprises a first electrical contact area (32) for communicating data in accordance with a universal serial bus standard. The second row (E) comprises a second electrical contact area (34) for communicating data in accordance with the universal serial bus standard. The intermediate zone between the first and the second electrical contacts (32, 34) is electrically insulated with respect to signal ground. For example, in the Figure 6 embodiment, the intermediate zone comprises a floating zone of metallization (62). In an alternative embodiment, this zone of metallization (62) may be omitted so that the intermediate zone is constituted by a non-conductive surface.

Referring to Figures 1, 2 and 6, an advantage of the second set of basic characteristics is that the resilient contact springs of the reader corresponding respectively to the external power supply areas of the module and to the external USB type data input areas are prevented from being short-circuited by the continuous intermediate zone of the contact face of the electronics module.

It should be noted that the first and the second set of basic characteristics may be applied independently. That is, one may apply the first set of basic characteristics without applying the second set of basic characteristics and vice versa. However, it is advantageous to apply both sets of basic characteristics.

CLAIMS

1/ A card comprising electrical contacts for communicating in accordance with a universal serial bus standard, which card can be inserted in a card reader having complementary electrical contacts, the card having an insertion edge which traverses the complementary electrical contacts when the card is inserted in the card reader in a correct fashion, characterized in that the card comprises an electrical contact for receiving a power supply voltage which electrical contact is closer to the insertion edge than any electrical contact for communicating data in accordance with the universal serial bus standard.

15

2/ A card according to claim 1, characterized in that the electrical contacts are compatible with ISO standard 7816.

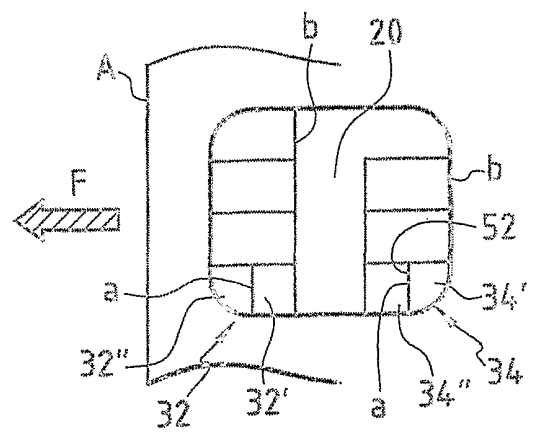
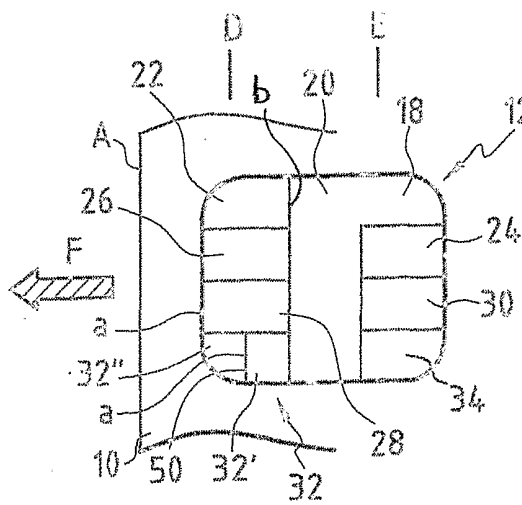
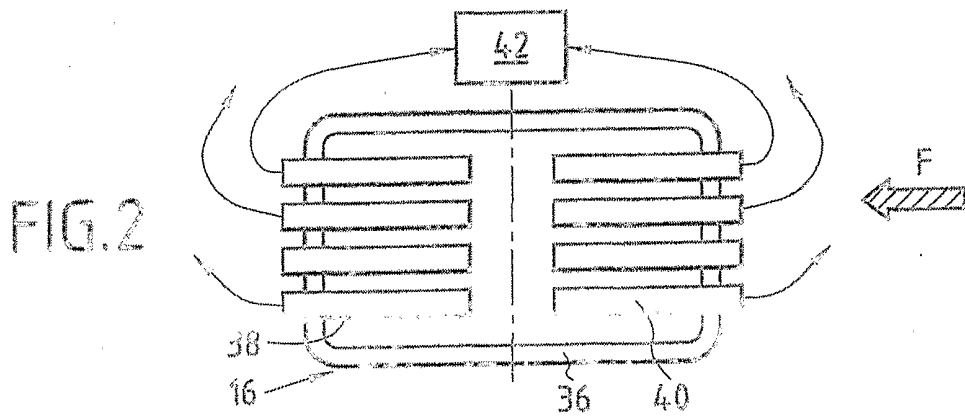
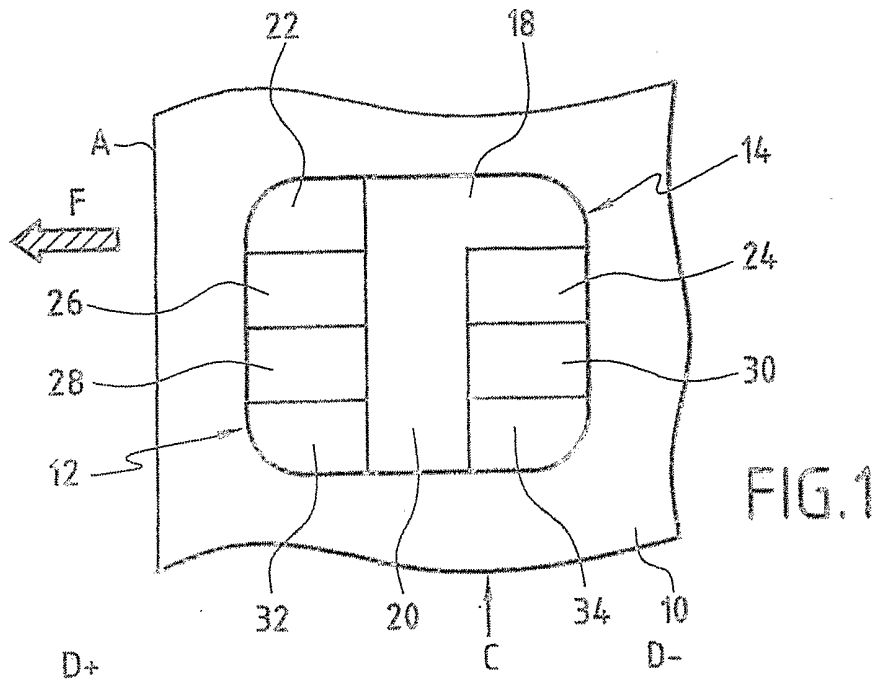

2/2

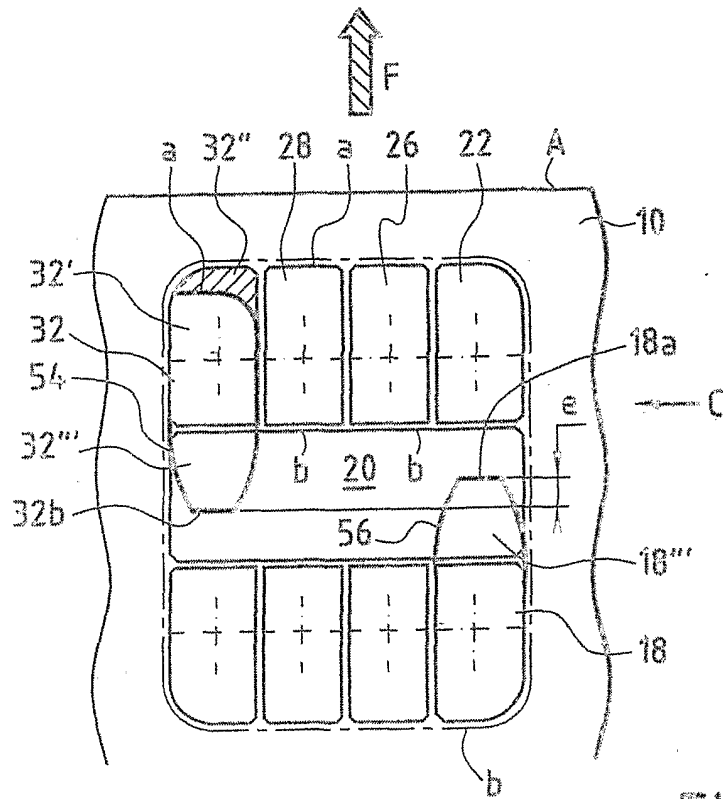

FIG. 5

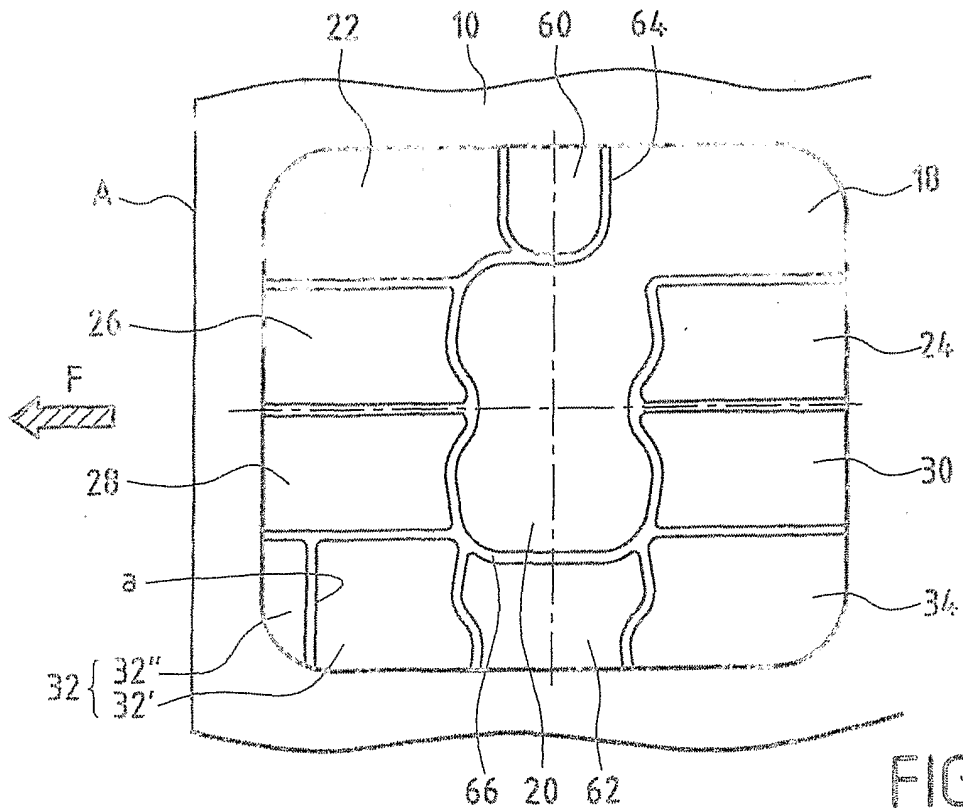

FIG. 6

INTERNATIONAL SEARCH REPORT

International Application No
PC. 01/00739

A. CLASSIFICATION OF SUBJECT MATTER
IPC 7 G06K19/077

According to International Patent Classification (IPC) or to both national classification and IPC

B. FIELDS SEARCHED

Minimum documentation searched (classification system followed by classification symbols)
IPC 7 G06K G06F

Documentation searched other than minimum documentation to the extent that such documents are included in the fields searched

Electronic data base consulted during the international search (name of data base and, where practical, search terms used)

EPO-Internal

C. DOCUMENTS CONSIDERED TO BE RELEVANT

Category *	Citation of document, with indication, where appropriate, of the relevant passages	Relevant to claim No.
Y	FR 2 783 336 A (SCHLUMBERGER IND SA) 17 March 2000 (2000-03-17) page 8, line 18 - line 24 figure 5	1,2
Y	EP 0 402 055 A (IBM) 12 December 1990 (1990-12-12) column 1, line 1 - line 55 figure 5	1,2
A	DE 196 39 025 A (SIEMENS AG) 2 April 1998 (1998-04-02) figure 9B	1,2
A	FR 2 769 734 A (RUE CARTES ET SYSTEMES DE) 16 April 1999 (1999-04-16) page 5, line 6 -page 7, line 14 figure 1	1,2

Further documents are listed in the continuation of box C.

Patent family members are listed in annex.

* Special categories of cited documents :

- *A* document defining the general state of the art which is not considered to be of particular relevance
- *E* earlier document but published on or after the international filing date
- *L* document which may throw doubts on priority claim(s) or which is cited to establish the publication date of another citation or other special reason (as specified)
- *O* document referring to an oral disclosure, use, exhibition or other means
- *P* document published prior to the international filing date but later than the priority date claimed

- *T* later document published after the international filing date or priority date and not in conflict with the application but cited to understand the principle or theory underlying the invention
- *X* document of particular relevance; the claimed invention cannot be considered novel or cannot be considered to involve an inventive step when the document is taken alone
- *Y* document of particular relevance; the claimed invention cannot be considered to involve an inventive step when the document is combined with one or more other such documents, such combination being obvious to a person skilled in the art.
- * & * document member of the same patent family

Date of the actual completion of the international search

26 July 2001

Date of mailing of the international search report

02/08/2001

Name and mailing address of the ISA

European Patent Office, P.B. 5818 Patentlaan 2
NL - 2280 HV Rijswijk
Tel: (+31-70) 340-2040, Tx. 31 651 epo nl,
Fax: (+31-70) 340-3016

Authorized officer

Goossens, A

INTERNATIONAL SEARCH REPORT

Inter national Application No

PCT/IB 01/00739

Patent document cited in search report	Publication date	Patent family member(s)	Publication date
FR 2783336 A	17-03-2000	EP 1110173 A WO 0016255 A	27-06-2001 23-03-2000
EP 0402055 A	12-12-1990	BR 9002709 A CA 2018069 A JP 3022118 A US 5210855 A	20-08-1991 09-12-1990 30-01-1991 11-05-1993
DE 19639025 A	02-04-1998	BR 9712107 A CN 1238856 A WO 9813870 A EP 0948815 A JP 2000505242 T	31-08-1999 15-12-1999 02-04-1998 13-10-1999 25-04-2000
FR 2769734 A	16-04-1999	EP 0915431 A	12-05-1999