



US 20130192618A1

(19) **United States**

(12) **Patent Application Publication**

Li et al.

(10) **Pub. No.: US 2013/0192618 A1**

(43) **Pub. Date: Aug. 1, 2013**

(54) **ATOMIZER FOR ELECTRONIC CIGARETTE**

(76) Inventors: **Yonghai Li**, Shenzhen (CN); **Zhongli Xu**, Shenzhen (CN)

(21) Appl. No.: **13/362,040**

(22) Filed: **Jan. 31, 2012**

Publication Classification

(51) **Int. Cl.**
A24F 47/00 (2006.01)

(52) **U.S. Cl.**
USPC **131/329**

(57) **ABSTRACT**

An atomizer for electronic cigarette comprises a mouth-piece, an atomization shell and a thread bushing. The atomization shell is a hollow pipe with its first end connected to the mouth-piece and second end sealed by a sealing sleeve and the thread bushing. An aerosol passage is provided inside the atomization shell. The aerosol passage has one end in communication with an orifice of the mouth-piece and another end communicating with the sealing sleeve muff-coupled to the thread bushing. The atomization shell has a first intermediary piece extending into the sealing sleeve for introducing tobacco liquid stored in the atomization shell into the sealing sleeve. An electric heater is provided between the sealing sleeve and the thread bushing. The electric heater heats up the tobacco liquid immersed in the first intermediary piece to make it atomized. The atomized tobacco liquid flows through the aerosol passage and is discharged through the mouth-piece.

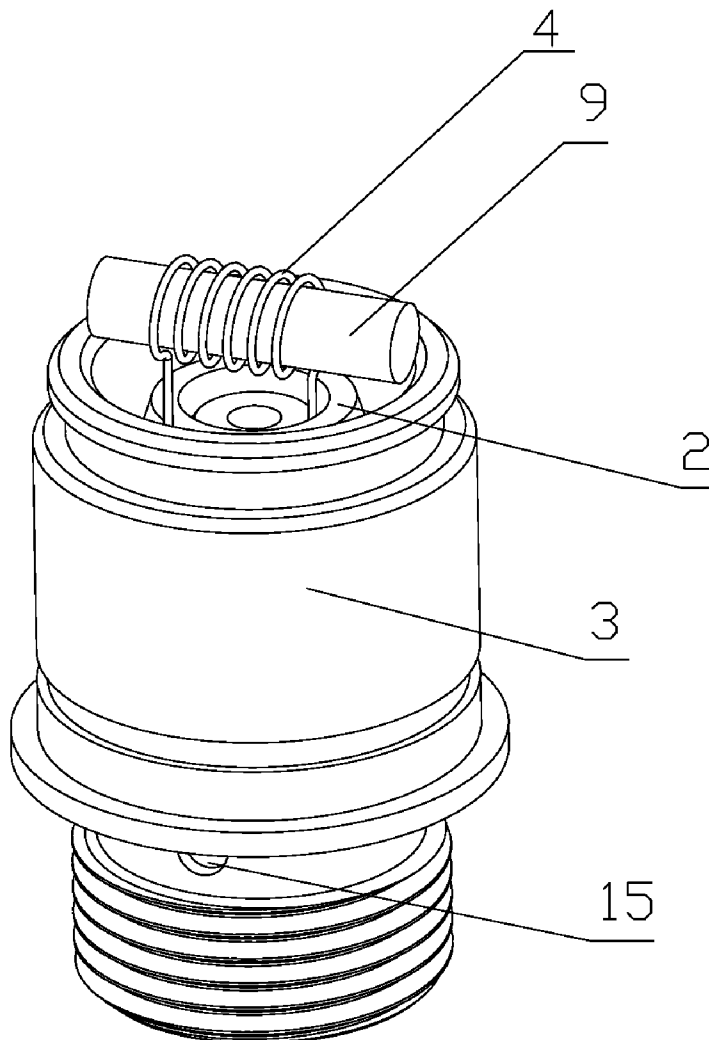

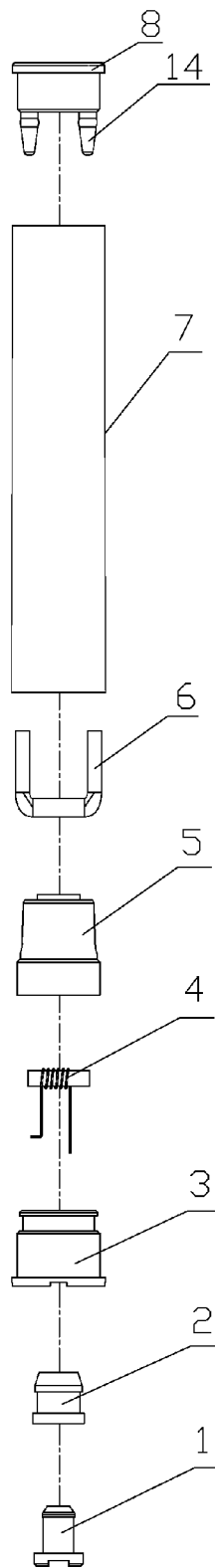

FIG. 1

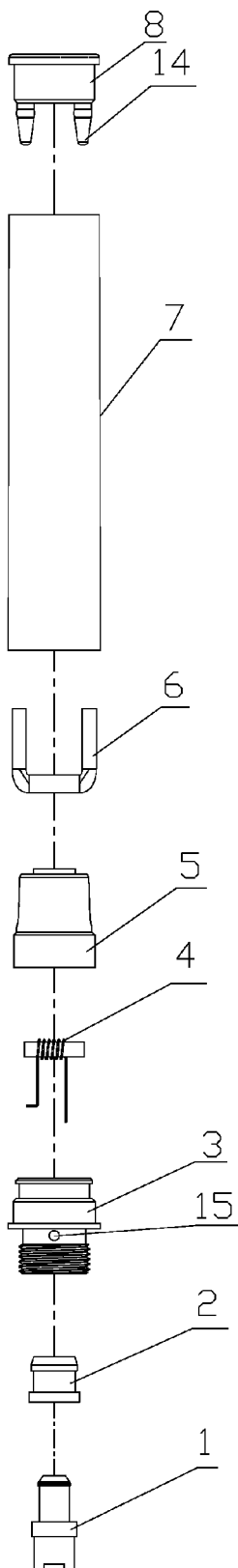

FIG. 2

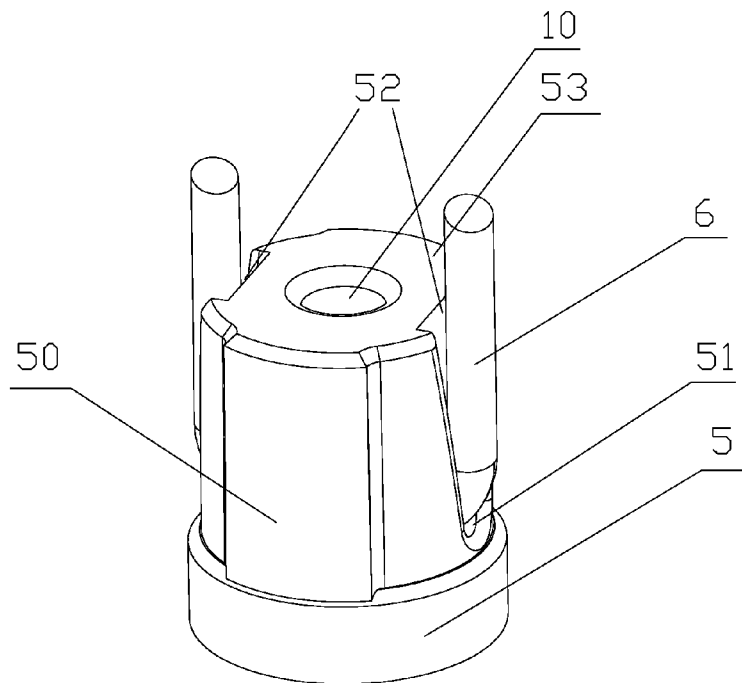

FIG. 3

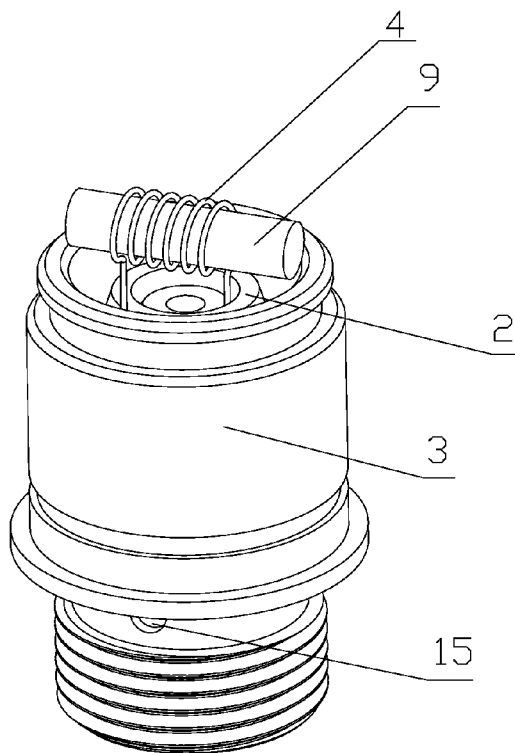

FIG. 4

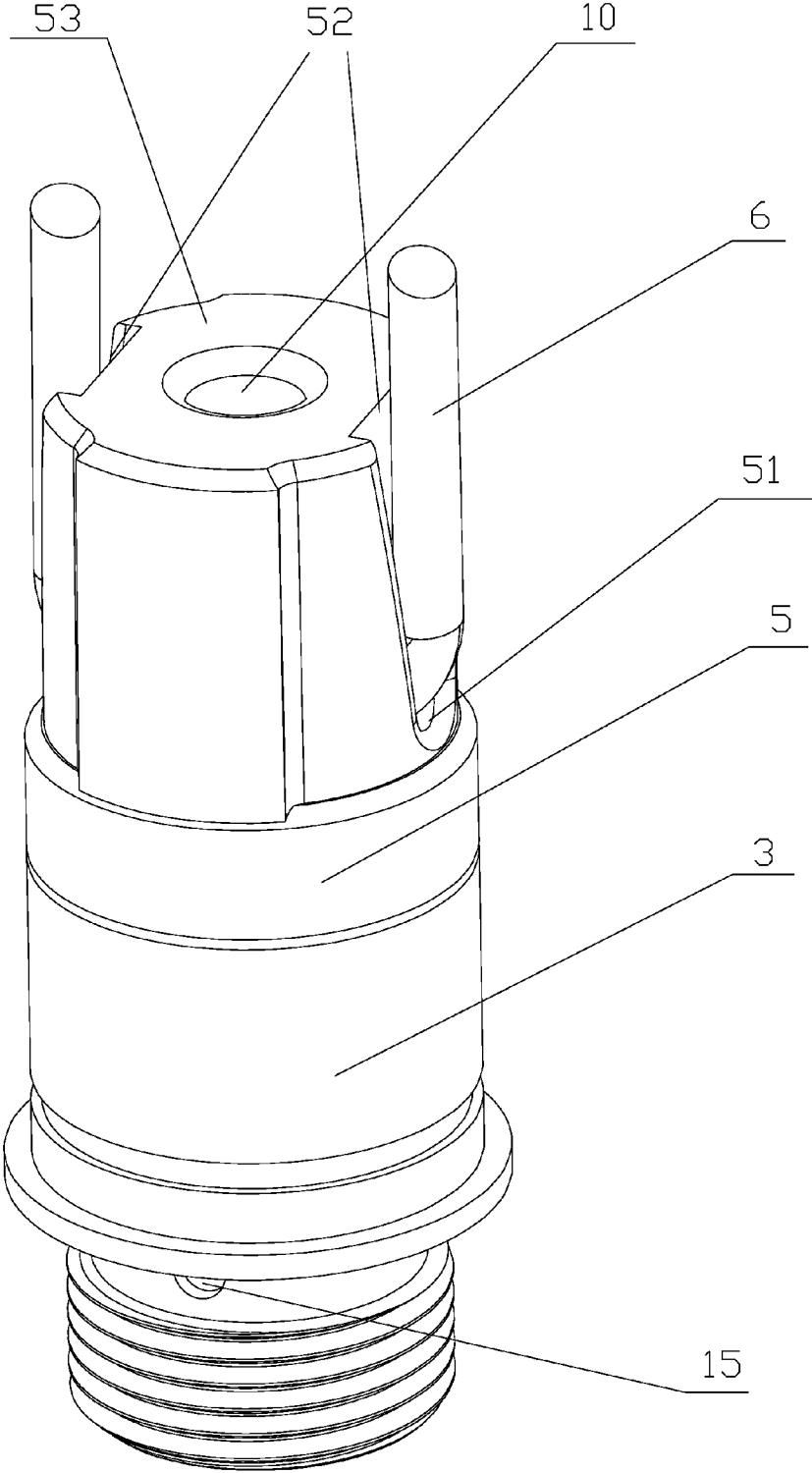

FIG. 5

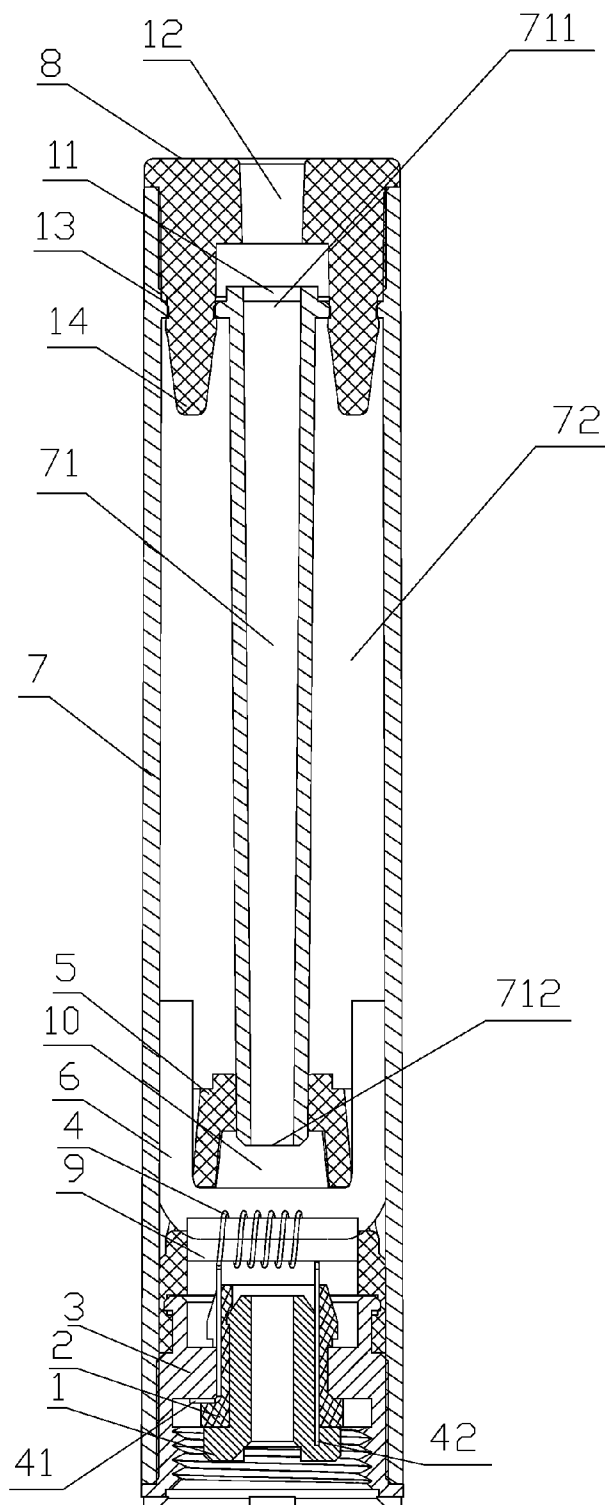

FIG. 6

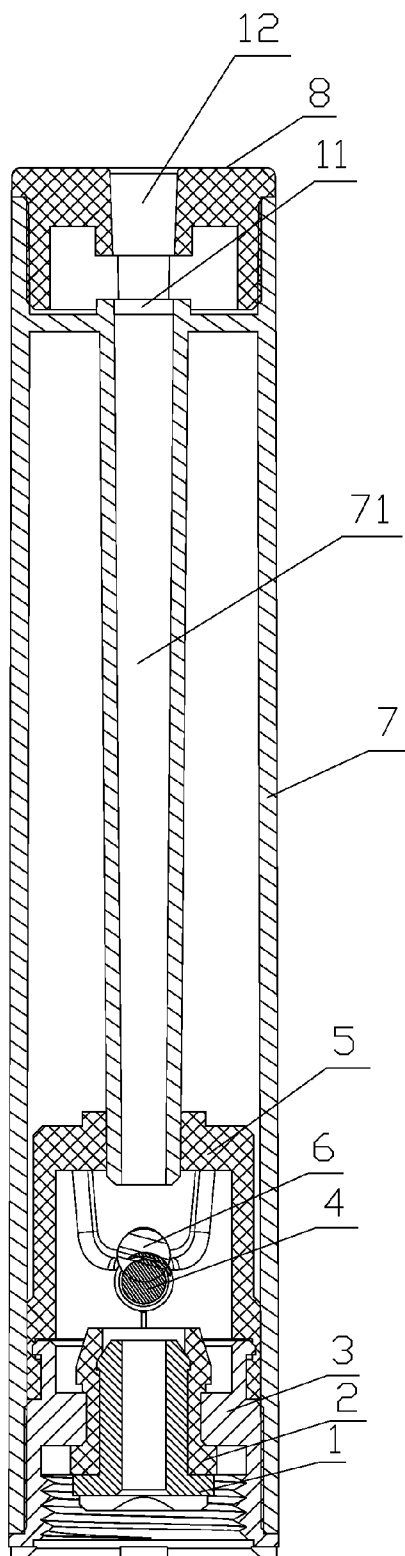

FIG. 7

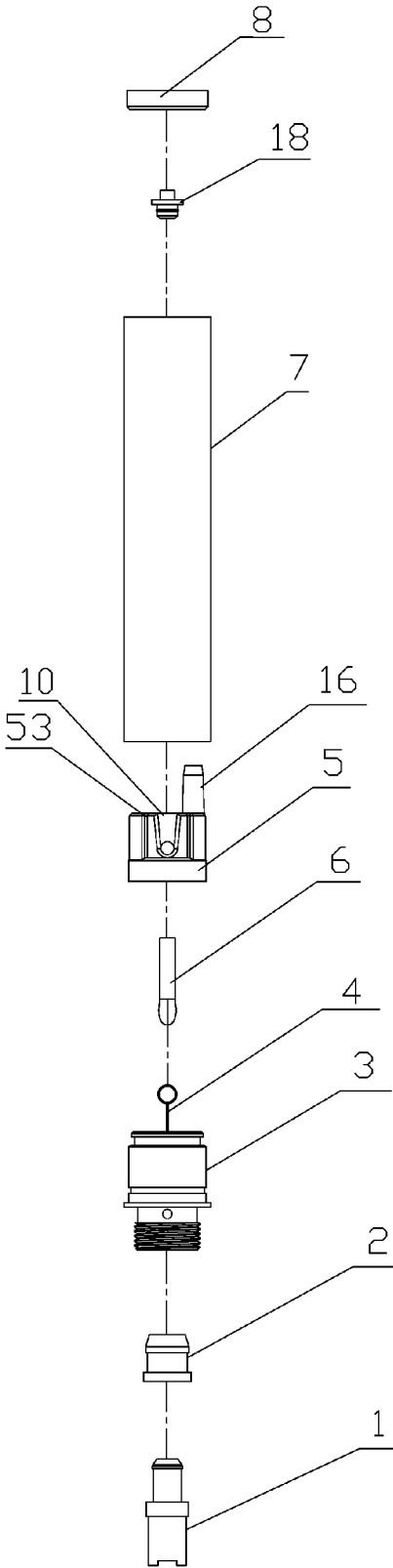

FIG. 8

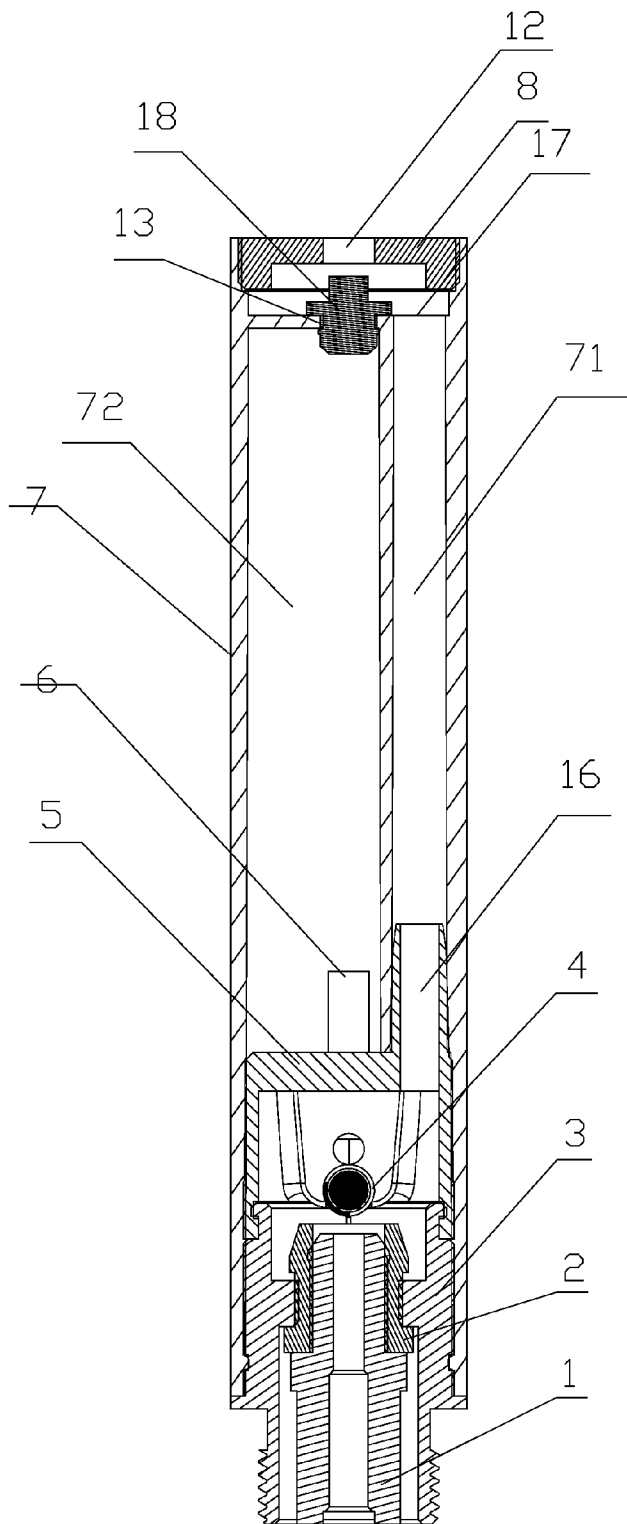

FIG. 9

ATOMIZER FOR ELECTRONIC CIGARETTE**BACKGROUND OF THE INVENTION**

[0001] 1. Field of the Invention

[0002] The present invention relates to an electronic cigarette, in particular to an atomizer for electronic cigarette which is easy to be produced and assembled, with a bigger room for storing tobacco liquid, and can be used for longer time.

[0003] 2. Description of the Prior Art

[0004] Cigarette is popular in the world, especially amongst men. However, tar in the cigarette is known harmful to human health, in which tens of ingredients are carcinogenic substances. Moreover, passive smoking can be more harmful to non-smokers. Therefore, smoking is prohibited in many public places. However, it remains extremely difficult for a smoker to quit smoking. Therefore, many cigarette substitutes have been proposed, among which the most common one is noncombustible electronic atomization cigarette which is free of tar.

[0005] Presently, almost all electronic cigarettes are made in integral structure. The electronic cigarette has a power supply at its front end of and an atomizer at its rear end. While the atomizer of the cigarette is powered by the power supply, an LED lamp of the power supply device is also lightened to simulate a burnt cigarette. A conventional atomizer comprises a glass fiber tube, a glass fiber core, a radiation core, a cotton cloth, and cellucotton. The radiation core located in the interior of the glass fiber tube is wound around the glass fiber core. The cotton cloth wraps the outer wall of the glass fiber tube and presses the exposed end of the glass fiber core in between the cotton cloth and the glass fiber tube. The cotton cloth is wrapped by the cellucotton. An annular room for storing the tobacco liquid is formed between the cotton cloth and the cellucotton. Two wires are welded on the radiation core and drawn through the glass fiber tube to the electrodes of the power supply. An electronic cigarette with such an atomizer is complicated in production and a room therein for storing tobacco oil is very small.

SUMMARY OF THE INVENTION

[0006] It is therefore an object of the present invention to provide an atomizer for electronic cigarette which is easy to make and assemble, with a bigger room for storing tobacco liquid, and able to be used for longer time.

[0007] To achieve this object, the present invention provides an atomizer for electronic cigarette comprising a mouth-piece, an atomization shell and a thread bushing, wherein

[0008] the atomization shell is a hollow pipe with its first end connected to the mouth-piece and its second end sealed by a sealing sleeve and the thread bushing, an aerosol passage being provided inside the atomization shell from its first end, the sealing sleeve being mounted on the thread bushing, the atomization shell further having a first intermediary piece therein which extends into the sealing sleeve for introducing tobacco liquid stored in the atomization shell into the sealing sleeve, and an electric heating element being provided between the sealing sleeve and the thread bushing, and wherein the electric heating element, upon powered through the thread bushing electrically connected to a battery, heats up the tobacco liquid immersed in the first intermediary piece to

make it atomized, the atomized tobacco liquid flowing through the aerosol passage and being discharged through the mouth-piece.

[0009] Preferably, the aerosol passage has a first end communicated with an orifice arranged in the mouth-piece and a second end communicated with the sealing sleeve. The atomization shell has a closed portion at its first end with at least two injection openings being provided on the closed end surface surrounding the aerosol passage. The mouth-piece is provided with silicone plugs for blocking the injection openings.

[0010] Preferably, the sealing sleeve is a hollow cylinder with its one end closed and another end opened. A through hole is provided at the center of the closed end of the cylinder for introducing the first intermediary piece into the sealing sleeve. A duct is arranged on the closed end of the sealing sleeve aside of the center of the closed end and the duct is communicated into the sealing sleeve and formed with the sealing sleeve in one piece.

[0011] Preferably, the atomization shell has a closed portion at its first end with an inlet and an outlet being provided on the closed end surface thereof. The inlet is blocked by a stopper and the outlet is communicated with the first end of the aerosol passage. The second end of the aerosol passage is muff-coupled to the duct.

[0012] Preferably, a tobacco liquid storage room is defined by the outer sidewall of the aerosol passage, the inner wall of the atomization shell and the sealing sleeve.

[0013] Preferably, the sealing sleeve is a hollow cylinder with its one end closed and another end opened. A through hole is provided at the center of the closed end of the cylinder. The second end of the aerosol passage is connected into the through hole. The sealing sleeve has apertures which are provided at the opposing positions on the outer wall of the sealing sleeve and communicated with the hollow interior of the cylinder. The sealing sleeve also has longitudinal grooves provided on the outer wall of the sealing sleeve at the upside of the apertures. The first intermediary piece is placed into the longitudinal grooves on the outer wall of the sealing sleeve and extends through the apertures to form a shape of U.

[0014] Preferably, an electrode ring is clamped in the thread bushing and an insulation ring is interposed between the thread bushing and the electrode ring for electrically isolating the electrode ring connected to the anode of the battery from the thread bushing connected to the cathode of the battery.

[0015] Preferably, the electric heating element is solenoid-shaped with its one end clamped between the thread bushing and the insulation ring and another end clamped between the insulation ring and the electrode ring. And a second intermediary piece is inserted inside the solenoid-shaped electric heating element.

[0016] Preferably, the electric heating element is ring-shaped. The second end of the intermediary piece passes through the through hole provided at the center of the closed end of the cylinder and is clamped in the ring-shaped electric heating element. The first end of intermediary piece is placed in the tobacco liquid storage room for absorbing tobacco liquid.

[0017] Preferably, the first and the second intermediary piece are pressed to each other through coupling of the sealing sleeve and the thread bushing.

[0018] In the atomizer for electronic cigarette according to the present invention, an oil transmission mechanism is used to lead tobacco liquid onto the heating element, while an annular room for storing tobacco liquid is defined by a sealing

sleeve and an aerosol passage within the atomization shell. Thus, it improves the capability of storing tobacco liquid. Moreover, the atomizer for electronic cigarette according to the present invention does not use tar absorbing cotton, etc. which greatly simplifies manufacture of the electronic cigarette product. Further, because the electric heating element according to the present invention is not connected in the atomizer through a welding procedure, this kind atomizer is much better for environmental protection.

BRIEF DESCRIPTION OF THE DRAWINGS

[0019] FIG. 1 is a breakdown schematic diagram of an atomizer according to the first embodiment of the present invention;

[0020] FIG. 2 is a breakdown schematic diagram of an atomizer according to the second embodiment of the present invention;

[0021] FIG. 3 is a schematic diagram illustrating the connection between the sealing sleeve and an intermediary piece according to an embodiment of the present invention;

[0022] FIG. 4 is a schematic diagram of thread bushing according to an embodiment of the present invention;

[0023] FIG. 5 is a schematic diagram illustrating the connection between the sealing sleeve and the thread bushing according to an embodiment of the present invention;

[0024] FIG. 6 is a cross-section diagram of an atomizer according to an embodiment of the present invention;

[0025] FIG. 7 is a cross-section diagram of an atomizer according to the second embodiment of the present invention;

[0026] FIG. 8 is a breakdown schematic diagram of an atomizer according to the third embodiment of the present invention; and

[0027] FIG. 9 is a cross-section diagram of an atomizer according to the third embodiment of the present invention.

DETAILED DESCRIPTION OF THE PREFERRED EMBODIMENTS

[0028] The present invention is further described with reference to the accompanied drawings.

[0029] As shown in FIGS. 1, 3, 4, 5 and 6, in an embodiment an atomizer for an electronic cigarette comprises a mouth-piece 8, an atomization shell 7 and a thread bushing 3.

[0030] Thread bushing 3 can be an inner thread bushing as shown in FIG. 1, or an external thread bushing as shown in FIG. 2, which is connected to the cathode of the battery. In case of an external thread bushing, an air inlet 15 is provided at one end of thread bushing 3 close to the thread, with the other end being a fixing part for sealing and connecting to a second end of the atomization shell 7. An electrode ring 1 is clamping connected at one end with the inside wall of thread bushing 3 and connected at the other end to the anode of the battery. An insulation ring 2 is provided between the electrode ring 1 and the thread bushing 3 to electrically isolate the electrode ring 1 from the thread bushing 3.

[0031] The atomization shell 7 is a hollow tube with a sealing sleeve 5 which is a hollow cylinder fixed therein. As shown in FIGS. 3, 5 and 6, two opposite holes 51 are provided at the sidewall 50 of the sealing sleeve 5 and are communicated with the hollow interior of the sealing sleeve 5. A longitudinal groove 52 is provided at the upper side of each hole of the sealing sleeve 5. The sealing sleeve 5 is coupled with the thread bushing 3. A first intermediary piece 6 extends through a hole 51 in the sidewall 50 of the sealing sleeve 5 and

the axes of the sealing sleeve 5 to the opposite hole in the sidewall 50 of the sealing sleeve 5. In this way, both the ends of the first intermediary piece 6 are positioned in the longitudinal grooves 52 of the inner wall of the sealing sleeve 5 and extend over the upper portion of the closing end 53 of the sealing sleeve 5, thus reducing the occupation of the first intermediary piece 6 in the atomization shell 7. In this case the first intermediary piece 6 is "U" shaped. A through hole 10 for passing through smoke is formed at the closing end 53 of the sealing sleeve 5 along the axes thereof. An aerosol passage 71 is provided closing to a first end 70 within the atomization shell 7. A first end 711 of the aerosol passage 71 is communicated with the orifice 12 of the mouth-piece 8. A second end 712 of the aerosol passage 71 is communicated with the through hole 10 of the sealing sleeve 5. Thus, a closed ring-shaped tobacco liquid storage room is formed by the outer sidewall of the aerosol passage 71, the inner sidewall 72 of the atomization shell 7 and the sealing sleeve 5.

[0032] The opening end of the sealing sleeve 5 is muff-coupled to a threadless end of the thread bushing 3. The external diameter of the opening end is matched with the inner diameter of the atomization shell 7 so as to prevent tobacco liquid from flowing out.

[0033] An electric heating element 4 is provided between the sealing sleeve 5 and the thread bushing 3. The heating element 4 may be a solenoid heating elements. A second intermediary piece 9 is provided to extend through the solenoid coil of the electric heating element 4. One end 41 of the electric heating element 4 is inserted and clamped in between the thread bushing 3 and the insulation ring 2. The other end 42 of the electric heating element 4 is inserted and clamped in between the insulation ring 2 and the electrode ring 1. In this way, the electric heating element 4 is powered through the thread bushing 3 connected to the cathode of the battery and the electrode ring 1 connected to the anode of the battery.

[0034] Then, The opening end of the sealing sleeve 5 is muff-coupled to a threadless end of the thread bushing 3 to make the first intermediary piece 6 abut against the second intermediary piece 9 so that both the intermediary pieces are pressed tightly together. In an embodiment of the invention, the intermediary pieces may use those materials being capable of transporting liquid, such as glass fiber, cotton thread or the like. Thus, the first intermediary piece 6 can transmit the tobacco liquid from the tobacco liquid storage room to the second intermediary piece 9. The tobacco liquid in the second intermediary piece 9 is atomized by the electric heating element 4, enters the aerosol passage 71 through the through hole 10 of the sealing sleeve 5, and is finally inhaled by a smoker.

[0035] The mouth-piece 8 is also muff-coupled with the first end 70 of the atomization shell 7. An orifice 12 communicating with the first end 711 of the aerosol passage 71 is provided at the mouth piece 8. The interior of the first end 70 of the atomization shell 7 is closed. Two injection openings 13 are provided opposite to each other around the aerosol passage 71 at the closed end surface of the interior of the first end of the atomization shell 7. Two silicone plugs 14 are provided correspondingly at the mouth-piece 8 for plug in the injection openings 13. Thus, after the tobacco liquid in the tobacco liquid storage room exhausts, the electronic cigarette can be refilled with the tobacco liquid by removing the mouth-piece 8 and injecting the tobacco liquid into the injection openings 13. The mouth-piece 8 is put back after the tobacco liquid is finished so that the electronic cigarette can be used again.

There is no limitation on the number of the injection openings **13**, whilst in the present embodiment two injection openings **13** are used. In this arrangement, when the tobacco liquid is injected through one opening **13**, air in the tobacco liquid storage room can be discharged from the other opening **13**.

[0036] FIG. 7 shows an atomizer according to the second embodiment of the invention. As shown in FIG. 7, in this embodiment, no liquid injection opening **13** is provided at the closed end surface of the interior of the first end of the atomization shell **7**, and no silicone plug **14** is provided, either. The atomizer is thus disposable, which does not permit refilling after exhaustion of the tobacco liquid in the tobacco liquid storage room. As another embodiment, the second intermediary piece **9** can be omitted. In this embodiment, the first intermediary piece **6** is led through the hole at the opposite side of the sealing sleeve **5**, then stretches out from the bottom of the sealing sleeve **5** to surround the electric heating element **4**, and finally is pulled back to its initial position to connect to the electrode of the battery. In this way, the atomization function of the electronic cigarette can also be realized.

[0037] FIG. 8 and FIG. 9 indicate an atomizer according to the third embodiment of the present invention. As shown in FIGS. 8 and 9, in this embodiment, the atomization shell **7** is a hollow pipe with a sealing sleeve **5** in the shape of hollow cylinder arranged inside the pipe. The sealing sleeve **5** has a closed end and an opened end. A through hole **10** for introducing tobacco liquid into interior of the sealing sleeve **5** is formed at the center of the closing end **53** of the sealing sleeve **5**. A duct **16** is arranged on the closed end of the sealing sleeve aside of the center of the closed end **53**. This duct **16** is communicated into the sealing sleeve **5** and formed with the sealing sleeve **5** in one piece. The duct **16** is provided such that its outer side wall is aligned longitudinally with side wall of the sealing sleeve **5**. The sealing sleeve is muff-coupled to the thread bushing. In this embodiment, one end of the first intermediary piece **6** passes through the through hole **10** at the center of the closing end **53** of the sealing sleeve **5** and is clamped in the electric heating element **4** which is a ring-shaped element in the embodiment. Another end of the first intermediary piece **6** is placed in the tobacco liquid storage room for absorbing tobacco liquid. The atomization shell **7** has a closed portion at its first end with an inlet **13** and an outlet **17** being provided on the closed end surface thereof. The inlet **13** is blocked by a stopper **18** and the outlet **17** is communicated with the first end of the aerosol passage **71**. And the second end of the aerosol passage **71** is muff-coupled to the duct **16**. In this way, a room **72** for storing tobacco liquid is defined by the outer sidewall of the aerosol passage **71**, the inner wall of the atomization shell **7** and the sealing sleeve **5**. When the tobacco liquid exhausts, the stopper **18** blocked at the inlet **13** can be removed in order to refill the tobacco liquid.

[0038] Although the details of the invention have been described in view of the above illustration, various modifications and variations may be made without departing from the spirit and scope of the invention. It is intended that the scope of the invention is defined by the following claims and their equivalents.

What is claimed:

1. An atomizer for electronic cigarette comprising a mouth-piece, an atomization shell and a thread bushing, wherein the atomization shell is a hollow pipe with its first end connected to the mouth-piece and its second end sealed by a sealing sleeve and the thread bushing, an aerosol

passage being provided inside the atomization shell from its first end, the sealing sleeve being mounted on the thread bushing, the atomization shell further having a first intermediary piece therein which extends into the sealing sleeve for introducing tobacco liquid stored in the atomization shell into the sealing sleeve, and an electric heating element being provided between the sealing sleeve and the thread bushing, and

wherein the electric heating element, upon powered through the thread bushing electrically connected to a battery, heats up the tobacco liquid immersed in the first intermediary piece to make it atomized, the atomized tobacco liquid flowing through the aerosol passage and being discharged through the mouth-piece.

2. The atomizer for electronic cigarette according to claim 1, wherein the aerosol passage has a first end communicated with an orifice arranged in the mouth-piece and a second end communicated with the sealing sleeve, wherein the atomization shell has a closed portion at its first end with at least two injection openings being provided on the closed end surface surrounding the aerosol passage and the mouth-piece is provided with silicone plugs for blocking the injection openings.

3. The atomizer for electronic cigarette according to claim 1, wherein the sealing sleeve is a hollow cylinder with its one end closed and another end opened, a through hole being provided at the center of the closed end of the cylinder for introducing the first intermediary piece into the sealing sleeve, a duct being arranged on the closed end of the sealing sleeve aside of the center of the closed end, the duct being communicated into the sealing sleeve and formed with the sealing sleeve in one piece.

4. The atomizer for electronic cigarette according to claim 3, wherein the atomization shell has a closed portion at its first end with an inlet and an outlet being provided on the closed end surface thereof, the inlet being blocked by a stopper and the outlet being communicated with the first end of the aerosol passage, and the second end of the aerosol passage being muff-coupled to the duct.

5. The atomizer for electronic cigarette according to claim 1, wherein a tobacco liquid storage room is defined by the outer sidewall of the aerosol passage, the inner wall of the atomization shell and the sealing sleeve.

6. The atomizer for electronic cigarette according to claim 2, wherein a tobacco liquid storage room is defined by the outer sidewall of the aerosol passage, the inner wall of the atomization shell and the sealing sleeve.

7. The atomizer for electronic cigarette according to claim 3, wherein a tobacco liquid storage room is defined by the outer sidewall of the aerosol passage, the inner wall of the atomization shell and the sealing sleeve.

8. The atomizer for electronic cigarette according to claim 4, wherein a tobacco liquid storage room is defined by the outer sidewall of the aerosol passage, the inner wall of the atomization shell and the sealing sleeve.

9. The atomizer for electronic cigarette according to claim 5, wherein the electric heating element is ring-shaped, the second end of the intermediary piece passing through the through hole provided at the center of the closed end of the cylinder and clamped in the ring-shaped electric heating element, and the first end of intermediary piece being placed in the tobacco liquid storage room for absorbing tobacco liquid.

10. The atomizer for electronic cigarette according to claim 6, wherein the electric heating element is ring-shaped, the second end of the intermediary piece passing through the

through hole provided at the center of the closed end of the cylinder and clamped in the ring-shaped electric heating element, and the first end of intermediary piece being placed in the tobacco liquid storage room for absorbing tobacco liquid.

11. The atomizer for electronic cigarette according to claim 7, wherein the electric heating element is ring-shaped, the second end of the intermediary piece passing through the through hole provided at the center of the closed end of the cylinder and clamped in the ring-shaped electric heating element, and the first end of intermediary piece being placed in the tobacco liquid storage room for absorbing tobacco liquid.

12. The atomizer for electronic cigarette according to claim 8, wherein the electric heating element is ring-shaped, the second end of the intermediary piece passing through the through hole provided at the center of the closed end of the cylinder and clamped in the ring-shaped electric heating element, and the first end of intermediary piece being placed in the tobacco liquid storage room for absorbing tobacco liquid.

13. The atomizer for electronic cigarette according to claim 1, wherein the sealing sleeve is a hollow cylinder with its one end closed and another end opened, a through hole being provided at the center of the closed end of the cylinder, the second end of the aerosol passage being connected into the through hole, the sealing sleeve having apertures which are provided at the opposing positions on the outer wall of the

sealing sleeve and communicated with the hollow interior of the cylinder, the sealing sleeve also having longitudinal grooves provided on the outer wall of the sealing sleeve at the upside of the apertures, and the first intermediary piece being placed into the longitudinal grooves on the outer wall of the sealing sleeve and extending through the apertures to form a shape of U.

14. The atomizer for electronic cigarette according to claim 1, wherein an electrode ring is clamped in the thread bushing and an insulation ring is interposed between the thread bushing and the electrode ring for electrically isolating the electrode ring connected to the anode of the battery from the thread bushing connected to the cathode of the battery.

15. The atomizer for electronic cigarette according to claim 14, wherein the electric heating element is solenoid-shaped with its one end clamped between the thread bushing and the insulation ring and another end clamped between the insulation ring and the electrode ring, and a second intermediary piece is inserted inside the solenoid-shaped electric heating element.

16. The atomizer for electronic cigarette according to claim 15, wherein the first and the second intermediary piece are pressed to each other through coupling of the sealing sleeve and the thread bushing.

* * * * *