

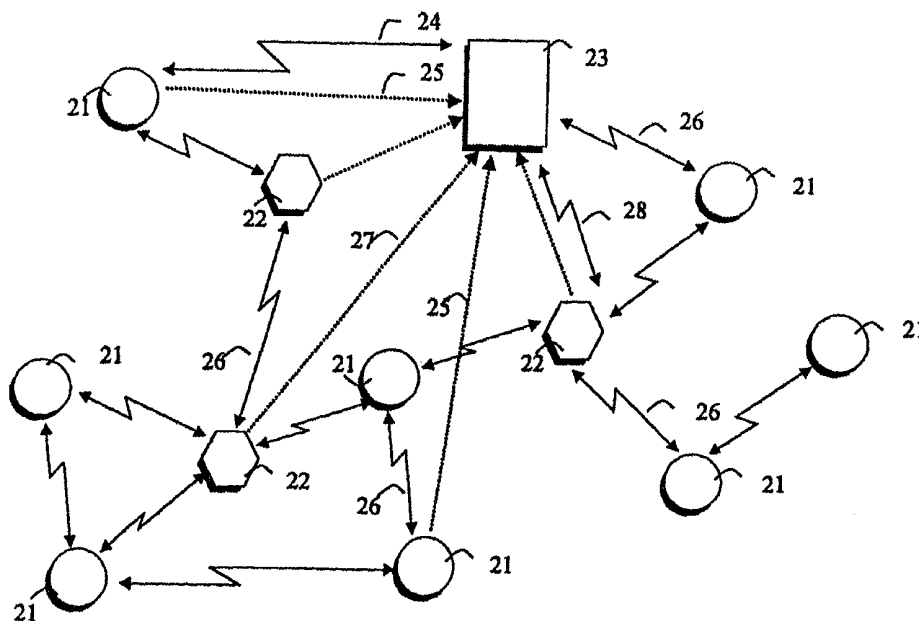

INTERNATIONAL APPLICATION PUBLISHED UNDER THE PATENT COOPERATION TREATY (PCT)

<p>(51) International Patent Classification ⁷ : G08B 21/00, 25/01</p>	<p>A1</p>	<p>(11) International Publication Number: WO 00/52658 (43) International Publication Date: 8 September 2000 (08.09.00)</p>
<p>(21) International Application Number: PCT/IL00/00108 (22) International Filing Date: 21 February 2000 (21.02.00) (30) Priority Data: 128784 1 March 1999 (01.03.99) IL (71) Applicant (for all designated States except US): COMM-TRACK LTD. [IL/IL]; Hahagana Street 120, 60373 Or Yehuda (IL). (72) Inventor; and (75) Inventor/Applicant (for US only): ALJADJEFF, Daniel [IL/IL]; Arlozorov Street 5, 55550 Kiriat Ono (IL). (74) Agents: LUZZATTO, Kfir et al.; Luzzatto & Luzzatto, P.O. Box 5352, 84152 Beer-Sheva (IL).</p>		<p>(81) Designated States: AE, AL, AM, AT, AU, AZ, BA, BB, BG, BR, BY, CA, CH, CN, CR, CU, CZ, DE, DK, DM, EE, ES, FI, GB, GD, GE, GH, GM, HR, HU, ID, IL, IN, IS, JP, KE, KG, KP, KR, KZ, LC, LK, LR, LS, LT, LU, LV, MA, MD, MG, MK, MN, MW, MX, NO, NZ, PL, PT, RO, RU, SD, SE, SG, SI, SK, SL, TJ, TM, TR, TT, TZ, UA, UG, US, UZ, VN, YU, ZA, ZW, ARIPO patent (GH, GM, KE, LS, MW, SD, SL, SZ, TZ, UG, ZW), Eurasian patent (AM, AZ, BY, KG, KZ, MD, RU, TJ, TM), European patent (AT, BE, CH, CY, DE, DK, ES, FI, FR, GB, GR, IE, IT, LU, MC, NL, PT, SE), OAPI patent (BF, BJ, CF, CG, CI, CM, GA, GN, GW, ML, MR, NE, SN, TD, TG). Published <i>With international search report.</i></p>

(54) Title: SECURITY NETWORK AND SYSTEM



(57) Abstract

A security system comprising a plurality of home-based units provided with ranging means, the plurality of home-based units being in communication with a communication center, and a plurality of mobile/portable units related or unrelated to the home-based units. Each mobile/portable unit is capable of communicating with one or more home-based units located in its proximity. The system may further comprise direction finding means and operate in a license-free band. The home-based units may be connected to, or integrated into, a home alarm unit, a computer or an electronic device. The ranging means of the home-based units may use spread spectrum techniques.

FOR THE PURPOSES OF INFORMATION ONLY

Codes used to identify States party to the PCT on the front pages of pamphlets publishing international applications under the PCT.

AL	Albania	ES	Spain	LS	Lesotho	SI	Slovenia
AM	Armenia	FI	Finland	LT	Lithuania	SK	Slovakia
AT	Austria	FR	France	LU	Luxembourg	SN	Senegal
AU	Australia	GA	Gabon	LV	Latvia	SZ	Swaziland
AZ	Azerbaijan	GB	United Kingdom	MC	Monaco	TD	Chad
BA	Bosnia and Herzegovina	GE	Georgia	MD	Republic of Moldova	TG	Togo
BB	Barbados	GH	Ghana	MG	Madagascar	TJ	Tajikistan
BE	Belgium	GN	Guinea	MK	The former Yugoslav Republic of Macedonia	TM	Turkmenistan
BF	Burkina Faso	GR	Greece			TR	Turkey
BG	Bulgaria	HU	Hungary	ML	Mali	TT	Trinidad and Tobago
BJ	Benin	IE	Ireland	MN	Mongolia	UA	Ukraine
BR	Brazil	IL	Israel	MR	Mauritania	UG	Uganda
BY	Belarus	IS	Iceland	MW	Malawi	US	United States of America
CA	Canada	IT	Italy	MX	Mexico	UZ	Uzbekistan
CF	Central African Republic	JP	Japan	NE	Niger	VN	Viet Nam
CG	Congo	KE	Kenya	NL	Netherlands	YU	Yugoslavia
CH	Switzerland	KG	Kyrgyzstan	NO	Norway	ZW	Zimbabwe
CI	Côte d'Ivoire	KP	Democratic People's Republic of Korea	NZ	New Zealand		
CM	Cameroon			PL	Poland		
CN	China	KR	Republic of Korea	PT	Portugal		
CU	Cuba	KZ	Kazakstan	RO	Romania		
CZ	Czech Republic	LC	Saint Lucia	RU	Russian Federation		
DE	Germany	LI	Liechtenstein	SD	Sudan		
DK	Denmark	LK	Sri Lanka	SE	Sweden		
EE	Estonia	LR	Liberia	SG	Singapore		

SECURITY NETWORK AND SYSTEM

Field of the Invention

The present invention relates to a security network for the monitoring, tracking and searching of moving and stationary persons, animals and objects. More specifically, the invention relates to a wireless security network that uses home-based transceivers to provide monitoring, two-way messaging and location functions of individuals, animals or objects, in an area determined by the presence of said network transceivers.

BACKGROUND OF THE INVENTION

Security systems, which provide monitoring functions to wireless portable units associated to it, are well-known in the art. These systems are normally based on home fixed alarm means, which include a receiver able to receive emergency messages from said portable units (e.g. panic button). Emergency messages received from said portable units are sent to a monitoring center via telephone lines or other wireless methods (U.S. Patent No. 5,455,569). The operation area of those mobile units is limited to the area covered by the home receiver associated to it (tens to hundred feet).

Most of these systems (e.g. used for elderly and disabled people assistance), use very simple communication methods to transmit a panic signal and request assistance. The portable unit communicates only with the home unit associated to it. Those systems lack any ranging and

searching capabilities unless they use location information provided by another system (e.g. GPS).

Some other commercially available systems, which provide functions that are more advanced such range measurement (e.g. perimeter alert), etc. are also well known in the art. In many cases, they are used for monitoring offenders under house arrest, and are characterized by giving an alarm when a monitored person is at a distance from a base station greater than a predetermined threshold distance. The base station is connected to a telephone line and alerts the police or the security personnel that the threshold distance has been exceeded. Such systems are inherently limited for alert purposes only and do not have the capability to search or locate the monitored person even after the threshold distance has been exceeded. Examples of such systems are found in U.S. Patent Nos. 5,448,221, 5,255,306 and 4,980,671.

The prior art also deals with wireless networks based on special infrastructure, which provide several security functions as emergency messages, location, etc. Many examples are available including cellular systems (e.g. E911), GPS units combined with wireless networks, specialized mobile radio (SMR), multi-lateration systems, etc. Examples of such systems are found in U.S. Patent Nos. 5,802,454, 5,767,788, 5,742,233, 5,729,196, 5,673,305, 5,652,570, 5365,516 and 4,494,119.

Other prior art publications cover wireless networks which are used to transmit messages between mobile units, fixed units and communication centers. Message routing in these networks is performed using conventional prior art methods or specific methods for special

applications. Examples of such systems are found in U.S. Patent Nos. 5,737,318, 5,455,569 and 4,792,946.

However, the art has so far failed to provide a system that, uses subscriber and/or customer transceivers (e.g. home units, campus buildings, etc.) to create a distributed wireless security network which grows as new customer units are added and provides supervision, tracking, location and messaging capabilities, for mobile or fixed units in all the area covered by the network.

In view of the above, it is an object of the invention to provide a wireless security network and system that overcomes the deficiencies of conventional security systems.

It is a further object of the invention to provide a system which provided location and/or messaging and/or security services to a plurality of users, through home transmitting stations which are unrelated, or not necessarily related, to the person receiving the services. In this context, "home" includes any type of building, e.g., public buildings, office buildings, etc..

It is yet another object of the invention to provide a security network, which uses a plurality of license-free remote home transceivers having ranging means to provide supervision, tracking, location and messaging capabilities, of mobile or fixed units in an area covered by the network.

It is another object of the invention to provide a network and system in which each home transceiver having ranging means is normally associated with one or more mobile/portable units to provide security functions (e.g. emergency messages, monitoring, location, etc.).

It is still another object of the invention to provide a network and system in which one or more home transceivers having ranging means may communicate with mobile/portable units not associated to them, to provide said system functions (e.g. emergency messages, monitoring, location, etc.). In that way, mobile/portable units (e.g. panic buttons) are not limited to communicate only with those home transceivers units, which are associated to them.

It is another object of the present invention to provide a distributed security network and system in which mobile/portable units having wireless communication with license-free home transceivers having ranging means, may calculate their absolute position based on distances measured from said home transceivers and optionally transfer said location data to a center or other destination for further use.

It is another object of the present invention to provide a distributed security network and system in which mobile/portable units having wireless communication with license-free home transceivers having ranging means may calculate their relative position to said home transceivers, based on distances measured from said home transceivers and optionally transfer said position data to a center or other destination for absolute location calculation or other use, said absolute location being sent back to said mobile/portable unit and being used to locate said mobile/portable unit in a digitized map and/or perform self monitoring functions by said mobile/portable unit.

It is another object of the present invention to provide a distributed security network and system in which, said mobile/portable units may be located by the combined operation of said license-free home transceivers having ranging means, and mobile/portable units having ranging and direction finding means, based on distances measured from said home transceivers and said mobile/portable units having ranging and direction finding means.

It is still another object of the present invention that unidirectional or bi-directional range measurements performed by one of said license-free home transceivers having ranging means, to said mobile/portable unit, is used by other neighbor said license-free home transceivers having ranging means and being able to receive said range measurement messages to obtain data which may be used to calculate their respective distance to said mobile/portable unit without measuring the distance to said mobile/portable unit.

It is a further object of the present invention to provide a distributed security network and system in which, said license-free home transceiver include means to accommodate changes in the network topology and environment conditions.

It is an object of the present invention to provide a system in which said home transceivers in said security network uses distances measured or calculated between two neighbor transceivers to perform message routing.

It is still another object of the present invention to provide a system in which emergency messages originated from said mobile/portable units are routed to said associated home

transceivers and/or to said home transceivers which are located in the vicinity of said mobile/portable unit.

It is still another object of the invention to provide a network and system which its units are not limited to a predetermined setup, but which can be employed to host a plurality of guest personal devices.

Other objects and advantages of the invention will become apparent as the description proceeds.

SUMMARY OF THE INVENTION

The invention provides a security network and system that uses a plurality of license-free home-based units having ranging means and optionally direction finding means to provide supervision, tracking, location and messaging capabilities, of mobile or fixed units in an area covered by the network.

The network consists of a plurality of fixed, license-free remote transceivers units, optionally attached or integrated into a home alarm unit and having range measurement and optional direction finding means, of a single or a plurality of optional concentrator units which are license-free wireless transceivers, said unit or units installed in central alarm stations or concentration points and optionally having ranging and direction finding means, at least one communication center, said center being able to communicate with at least one home transceiver or one concentrator unit and having computing means, said home units and said concentrators maintaining between them two-way wireless communication, and a plurality of

portable and/or mobile units, said units including a transceiver being able to communicate with said home transceiver, said concentrator or other said portable and/or mobile units.

Said remote transceivers units, said concentrator units and some of said mobile/portable units have range measurement means (fixed or mobile/portable units) using spread spectrum techniques as described in PCT/IL98/00376. As also described in this specification, some units (fixed or mobile/portable) may preferably include one or more directional antenna means to perform direction finding.

The remote transceiver or said alarm unit attached to it (e.g. a home alarm unit) may also be connected to a PSTN or other wired line, in that way each said transceiver unit being able to communicate with one or more communication centers, other remote transceivers, other concentrators or any other destination, using said wired communication line.

Each said remote transceiver normally communicates with said mobile units associated to it (preferably associated to said transceiver during the unit setup) to perform monitoring, location, messaging and other security functions. In addition, said one or more home transceivers having ranging means, may communicate with mobile/portable units not associated to them, to provide said system functions (e.g. emergency messages, monitoring, location, etc.). In this way, mobile/portable units (e.g. with panic button means) are not limited to communicate only with those home transceivers units, which are associated with them. This capability expands the monitoring area of said home transceiver units far beyond the direct communication range between said home transceiver and said associated units.

The network according to the present invention enables a communication center or transceiver units to calculate the location of mobile/portable units, said transceivers having range measurement means using the measured and/or calculated distance to said mobile unit from a plurality of transceivers found in the proximity (within the communication range) of said mobile/portable unit.

Moreover, also said mobile/portable units are able to calculate their absolute or relative position to said home transceivers, by measuring the distance by itself or obtaining the distance from said transceivers. Said location data, being calculated either by a center or other unit and sent back to said mobile/portable unit or being calculated by said mobile/portable unit itself, may be used to show said mobile/portable unit position on a digitized map displayed in said unit or in an attached display or in an attached terminal unit having said display, said location data also used by said mobile/portable unit to perform different functions including self-monitoring, guidance, speed and direction measurement, etc.

Transceiver units having direction finding means in addition to range measurement means, may use said directional antenna to provide better location information (e.g. only two transceiver units are available to locate a mobile/portable unit) and to improve the network capacity.

The network, based on license-free home-based transceivers having range measurement and optional direction finding means, grows (i.e., the coverage area is expanded) and improves itself (location accuracy and message transfer capability are improved) as new home units are installed. The network uses dynamic configuration and routing which is basically not

dependent on any single node to perform any of said system functions. Message routing through the elements of the network is preferably performed using well-known prior art routing algorithms, or dedicated algorithms based on the measured or calculated distance between said network elements.

The communication center facility may be located anywhere inside or outside the network coverage area, and if required, may communicate with said network through different communication means, other than the wireless communication means used to communicate within the network.

All the system preferably operates in the ISM band, which is used in the U.S.A. and worldwide for unlicensed spread spectrum communication.

The system units make use of several technologies in order to achieve improved performance in noisy and/or problematic communication environments. The units communicate with one another using spread spectrum techniques. They use direct sequence coding to take advantage of the processing gain and ranging capabilities inherent in this coding technique. In addition, they use several means to improve the performance in multipath conditions, strong fading conditions, to overcome nulls and narrow band interference sources that may be present in the working band. In some cases, said units may use diversity antennae to improve even more the receiving conditions in cases of fading or nulls.

The communication center or similar security center may at any time, send information to any unit in the network, to perform any of the system functions (messaging, location, control,

setup, etc). In addition, special information may be disseminated to other units connected to other wired or wireless communication networks (cellular networks, paging systems, PSTN networks, etc.).

Brief Description of the Drawings

The objects and features of the invention will best be understood from a detailed description of the invention as shown in the accompanying drawings, in which:

Fig. 1 shows a remote transceiver (SPU) and its interface to a home alarm unit and to mobile/portable units, according to one preferred embodiment of the invention;

Fig. 2 schematically shows a remote transceiver block diagram (SPU) according to one preferred embodiment of the invention;

Fig. 3 schematically shows a security network, including remote transceivers, concentrator units and a center, according to a preferred embodiment of the invention;

Fig. 4 illustrates the timing of a simple range measurement operation, performed by a supervision unit (SPU), according to a preferred embodiment of the invention;

Fig. 5 illustrates the timing of a simple range measurement operation, performed by a supervision unit (SPU), and a second supervision unit listening to messages being transmitted, according to a preferred embodiment of the invention;

Fig. 6 illustrates the timing of a double range measurement operation, performed by a supervision unit (SPU), according to a preferred embodiment of the invention;

Fig. 7 illustrates the timing of a double range measurement operation, performed by a supervision unit (SPU), and a second supervision unit listening to messages being transmitted, according to a preferred embodiment of the invention; and

Fig. 8 illustrates a security network showing the distances between the network elements and their use for message routing, according to a preferred embodiment of the invention.

Detailed Description of Preferred Embodiments

The security network and system, according to the specific preferred embodiments of the invention to be described below with reference to Figs. 1 - 8, consists of the following basic units:

1. The mobile/portable unit which is carried by a person, animal or attached to any moving object. A suitable unit may be, e.g., a unit of the type described in the aforementioned International Patent Application PCT/IL98/00376, of the same applicant hereof, the description of which is entirely incorporated herein by reference. Such unit is preferably a monitored/searched unit - MSU or a monitoring and searching unit - SRU, both units according to preferred embodiments, having basically similar architecture, said SRU including range measurement and direction finding means. As will be apparent to the skilled person, both MSU and SRU may be implemented in several configurations for different requirements; and

2. The supervision unit - SPU, which is preferably a fixed transceiver unit having range measurement means, said transceiver installed in a home or in any other place, and principally used for supervising the mobile/portable units. In addition, it is also used for a plurality of other functions as described later in this document. Said SPU unit preferably attached to a home alarm unit or a group of home alarm units.

3. The concentrator unit - CTU, which is an optional unit, used to concentrate messages routed to a center (e.g. monitoring center) and optionally measure range and

azimuth to other units. This unit is similar to a remote transceiver, and may include several wireless communication channels to improve messaging capabilities as well as one or more wired communication channels to the center or other destinations. In a preferred embodiment, a CTU may be replaced by an SPU.

4. The communication center, which exchanges messages with any of the other network units and process said messages to perform system functions and also communicates with other units through other existing networks or directly connected.

In general, a specific MSU communicates with a supervisor unit (SPU) associated to it. This SPU may periodically monitor one or more of its associated MSU's, receive messages from it (e.g. emergency messages), etc. The communication range between the SPU and each of its associated MSU's is limited, among other factors, by the environmental conditions.

In a preferred embodiment of the invention, the SPU may be installed in a home and preferably attached to a home alarm unit. The home alarm unit may contact a communication center (e.g. monitoring center) through a PSTN line. As may be apparent to the skilled person, also the SPU may contact directly a communication center through said PSTN line or through any other wired or wireless communication link, which may be available, said wired or wireless link with the center optionally used as a communication backup for the home alarm system, being said alarm system connected to said SPU. In another preferred embodiment, said SPU serves a complete building, said building comprising two or more customer homes, said SPU being attached to a group of home alarm units and said SPU being preferably installed in the building roof or other appropriate location and connected to said customer home alarm units through wired or wireless communication channels. In another preferred

embodiment of the invention the SPU is attached or integrated in other electronic units, said units being a personal computer, a cordless telephone, a TV set, etc.

Referring now to the drawings and particularly to Fig. 1, the supervision unit SPU 3 according to the specific preferred embodiment of the invention shown in this figure, comprises an antenna 4 to transmit and receive signals to/from mobile/portable units 6, which are within the communication range of said SPU 3. Supervision unit 4 and said mobile portable units 6 preferably also comprise an antenna means 4, 7 which may be of different kinds as described in PCT/IL98/00376 for the MSU and SRU units. Wireless communication 5 between the SPU 3 and mobile/portable unit 6 is spread spectrum communication and preferably working in one or more of the ISM license-free bands (900 MHz, 2.4 GHz and 5.7 GHz bands). This communication link is preferably used for ranging purposes, direction finding, data messaging (e.g. emergency messages) and voice communication.

The SPU is preferably fixed installed and in a preferred embodiment, connected to a home alarm unit 1 through a wired interface 2. Data or signals may be transferred between said two units. In a preferred embodiment, the home alarm unit may contact a center through a PSTN line 8, said line being also used to transfer or receive information to/from said SPU unit. The SPU 3, may also send and/or receive data to/from other units in the network, as other SPU 9, etc.

Referring now to Fig.2, the SPU consists of two main blocks: A transmitter/receiver unit 12 and a data Processing and Control unit 14. In a preferred embodiment, the transmitter/receiver unit 12 being connected to a single omni-directional antenna 11, but in other cases said

transmitter/receiver unit being connected to an array of antennae, to directional antenna or combination of both. As may be obvious to the skilled person, the antenna or set of antennae may be internal or external, said antenna or antennae connected directly to said transmitter/receiver or mounted on a wall, etc. and connected to said transmitter/receiver via a cable. The receiver unit receives RF radio signal and converts them to digital signals subsequently processed by the Data processing and Control unit 14. Signals generated by the data processing unit 14 are modulated and transmitted by the transmitter unit 12. The interface 13 between the transmitter/receiver unit and the data processing unit includes transmit data signals, receive data signals, clocks, control lines, etc. The data processing and control unit includes digital logic means for range measurement, said logic means including correlating means, peak detection means and time measurement means, a microprocessing means, which consists of a processor, memories for storing program and data and I/O ports. Said Data processing and Control unit 14 in conjunction with said transmitter/receiver unit 12 and a directional antenna or array of antennae may be used to measure direction of a received message. Part of these I/O ports are preferably connected to a display means 16, used to display messages, alarms, controls, etc., an audio means used for any kind of voice communication as well as to reproduce prerecorded or synthesized audio messages through a small speaker 22 or similar device, alarms and other special sounds used for unit operation and unit controls 15, used to enable the user to setup, operate and test the SPU. In addition, the microprocessing means may exchange data with other electronic units through an external parallel or serial interface 17 (e.g. RS-232, etc.). The data processing and control 14 means controls the overall operation of the SPU.

As stated, the present invention is concerned with a network and system in which each home transceiver having ranging means is normally associated with one or more mobile/portable units to provide security functions (e.g. emergency messages, monitoring, location, etc.).

Moreover, the present invention provides a network and system in which one or more home transceivers having ranging means may communicate with mobile/portable units not associated to them, to provide said system functions (e.g. emergency messages, monitoring, location, etc.). In this way, mobile/portable units (e.g. panic buttons) are not limited to communicate only with said home transceivers units associated to them, said mobile/portable units being able to operate almost anywhere within the network area and being not limited by the communication range between said mobile/portable unit and said SPU.

Fig. 3 illustrates a preferred embodiment of the security network comprising a communication center 23, concentrator units 22, and supervision units 21, said supervision units having the capability to contact the communication center directly 25 (e.g. through a telephone line) and/or through a wireless link 24 or through other units of the network 26. In addition, the concentrator units 22, said concentrator units being optional units, may communicate directly with the communication center 23 via wired lines 27 or wireless lines 28, and with on or more of said supervision units 21.

A network as described in Fig. 3, allows an MSU (in other cases it may be an SRU), being said MSU out-of-the-range of its associated supervision unit, to be serviced by other supervision units, being said supervision units located in homes or other places, near to that said MSU. An emergency signal from such MSU unit is preferably routed to said

communication center through a telephone line, the wireless network or a combination of both. As may be apparent to the skilled person, all the examples described are also valid for an SRU replacing the MSU and many other communication systems (wired and wireless) may be used or combined to transfer messages to the center.

The supervision unit, which is in contact with said MSU in emergency, will preferably transmit both MSU and SPU identification codes enabling the security service provider to know the origin of the emergency signal and the code of the SPU which was in contact with said MSU. In a preferred embodiment, the SPU can also measure the distance to the MSU and optionally the azimuth thus enabling said SPU to provide said communication center with a more precise indication of said MSU location.

For example, when an MSU panic button is pressed, an emergency signal is preferably sent first to the supervision unit or units associated to it. If there is no response within a time limit, and said message being retried one or more times, an emergency signal is sent addressing any supervision unit being able to receive said message.

In many cases, a plurality of supervision units may receive the emergency signal, said supervision units being able to respond to said emergency signal. In a preferred embodiment, said supervision units preferably include an algorithm that controls the response timing and avoids collision being caused by possible simultaneous transmissions. Once the MSU is acknowledged by one or more of said supervision units, said emergency message is preferably directly sent (e.g. through a PSTN line) to the communication center or routed through the network.

When the MSU message reaches the communication center, it is processed and a response message is sent back to said MSU, said response message being sent preferably to said SPU that was in contact with said MSU either through a telephone line and/or via the wireless network.

According to the invention, and to a preferred embodiment, the supervision units, perform perimeter monitoring to their associated MSU's. Each MSU preferably communicates periodically with its associated SPU and the distance between them is then measured by said SPU. If said measured distance is below or beyond pre-programmed limits, a notification is preferably sent to a communication center or to any other programmed destination. In addition, the MSU itself is optionally alerted of being out of the permitted area. In another preferred embodiment, supervision units having direction finding capabilities, may combine azimuth and range measurement for their perimeter monitoring functions, said perimeter pre-programmed limits being a combination of both azimuth and minimum/maximum distance.

As will be apparent to the skilled person, perimeter monitoring may be programmed to fit different customer requirements, including allowed distances, allowed azimuths, MSU ID's, time of day, etc.

In another preferred embodiment of the invention, it is also possible to program more than one SPU to monitor an MSU. In this case, an SPU will monitor and alert according to its programmed parameters or according to monitoring parameters dynamically sent from said

MSU being monitored or another MSU which is also in contact with said SPU. As may be apparent to the skilled person, this function allows, among many others possibilities, an MSU unit to be monitored by different SPU's, said SPU's not being programmed in advance for monitoring said MSU.

As will be understood by the skilled person, it is also possible to increase the monitoring range of an SPU, by using the perimeter monitoring functions of neighbor SPU's.

The monitoring process may start automatically or manually after on or more MSU's are logged in the SPU, said SPU using monitoring parameters, said parameters preferably set-up by the user for each MSU or group of MSU's, or use the system default values. The parameters that may be defined, but not limited to, are:

1. Monitoring priority
2. Monitoring interval
3. Allowed distances
4. Allowed azimuths
5. History of monitoring events
6. Alert MSU
7. Type of alert
8. Messaging options

The SPU preferably adapts its operating parameters according to the unit being monitored, to the communication channel quality and other parameters. For example, an SPU is able to perform, but not limited to, an average of 10-100 distance measures per second

(600-6000 measures per minute). It has the possibility to change the interval time between two consecutive measures according to the application, channel load, distance from the MSU (measuring interval may be adapted to the distance, while far units are monitored more frequently than close units), azimuth to the MSU, user setup, etc. . The monitoring interval period of a specific MSU will preferably be in the range of 10-1200 seconds.

The network units make use of several technologies in order to achieve improved performance in noisy and/or problematic communication environments. Said units communicate each to other using spread spectrum techniques, said techniques using direct sequence coding to take advantage of the processing gain and ranging capabilities inherent in this coding technique. In addition, said units use other and/or additional means to improve the performance in multipath conditions, strong fading conditions, to overcome nulls and narrow band interference sources that may be present in the working band, said means being use of diversity antennae to improve even more the receiving conditions in cases of fading or nulls, directional antenna, frequency hopping techniques, etc.

When it is necessary to communicate with a mobile/portable unit, be it an MSU or SRU, to locate said mobile/portable unit, the associated SPU is preferably first accessed. This SPU will try to communicate with said MSU by sending to it messages, said messages being periodically sent or according to any other algorithm.

Once there is communication between the mobile/portable unit and the SPU, a notification is sent to the user or to the unit, which requested said operation. Then it is possible to measure the distance between said mobile/portable unit and said SPU, transfer messages between said two units or perform any other required function.

In certain cases, a specific SPU may fail to communicate with said mobile/portable unit, because said unit is out of the communication range or due to interference in the communication link. In such a case, it is possible to extend the searching area by said SPU asking from neighbor SPU's, to perform a "search for me" operation. Each of the contacted neighbors SPU's can initiate an acquisition process, said acquisition process being intended for first communicate with said mobile/portable unit. When any of the SPU's communicates with said MSU, the associated SPU will be notified including the measured distance from the MSU and optionally the measured azimuth. As may be apparent to the skilled person, this process may be further expanded to cover a large area within the network, but preferably, it is performed only by the direct or 2-level neighbors. Due to the natural cellular characteristic of the network, said limited operation will not significantly increase the load on the network. Transferring messages between said mobile/portable unit and its associated SPU, through the neighbor SPU, is relatively simple and does not require complicate routing algorithms. As may be apparent to the skilled person, in this manner, it is possible to expand the effective coverage area of a specific supervision unit and improve its success probability to communicate with a mobile/portable unit, said unit being an MSU or SRU according to the invention.

The selection of the appropriate neighbors to perform an acquisition may be done dynamically or based on previously stored information.

As explained in PCT/IL98/00376, the portable SRU unit is able to perform a manual search of an MSU or another SRU unit, said search operation being performed by measuring the azimuth and the distance to that MSU.

According to the present invention, and based on the described network and system, said searching process may be enhanced and carried out in different ways:

1. Single searcher
2. Several searchers
3. Combination of searchers and supervision units.

In a preferred embodiment of the invention, the network can assist to speed-up the searching process, said searching process started from the closest SPU that had communication with said MSU. In addition, a combined operation of a portable searcher (SRU) and at least two supervision unit enables to calculate the absolute location of said MSU, said location being calculated by using measured distances to said MSU, location of said SRU and SPU units and optionally azimuth information. In that way, the location process is completed much faster. The communication center may be periodically updated about the searching process, said updating process including an updated location of the searched MSU, calculated speed, etc.

As may be easily understood, network assistance for the search process does not require the communication center intervention, and may be performed locally, by SPU's located near the portable searcher and the searched MSU.

In another preferred embodiment of the invention, a message preferably originating from a communication center or a concentrator unit is sent to most or all the SPU's in a wide area, said center or said concentrator units requesting supervision units to perform an acquisition process with a specific MSU, said MSU being searched within a part or the whole network coverage area, or to respond to any message received from said MSU.

Once any of these SPU's contacted the said searched MSU, a notification including range information and optional azimuth information is preferably sent to the communication center and/or any other required destination.

As may be easily understood by the skilled person and using a location method which is well known in the prior art, the fixed installed units of this security network and system according to this invention may also be used to locate mobile/portable units.

At least three SPU's (may also be combined with CTU's having range measurement capabilities) are required to locate a mobile/portable unit, said mobile/portable unit being an MSU or SRU, by intersecting the circles drawn from the measured or calculated distance to that mobile/portable unit, the SPU being in the center of a circle where the measured distance is the radius and said location being improved by using said distances measured or calculated from more than three SPU's.

Although this location technique is well known in the art, compared to other commonly used prior art systems, which locate units by measuring the DTOA (difference time of arrival), this

security system does not require any time synchronization between the SPU's, thus significantly reducing the implementation cost.

In a preferred embodiment of the invention, a location algorithm calculates the expected position of the mobile/portable unit based on said distances and by taking in account other parameters that may indicate the quality of the distance measured or calculated, or improve the location calculation. These parameters preferably include signal strength, distance, SPU location, frequency offset, azimuth, etc.

Fig. 4 describes the basic timing when measuring the distance between an SPU and a mobile/portable unit, said mobile/portable being an MSU or SRU (for the sake of simplicity an MSU will be taken for the example). A supervision unit SPU#1 31 sends a message Tm 33 to an MSU 32, said transmitted message being received 35 at the MSU after a propagation delay Td 34. An additional short time, used to switch from receive to transmit mode Ts 36, is elapsed before the MSU transmits back a message Tm 37 which is synchronized to the received message 35, said transmitted message 37 being received 39 at the SPU#1 after a propagation delay Td 38, being this propagation delay normally very close to the previous propagation delay 34.

The distance is calculated by the SPU, by measuring the time from the beginning of Tm 33 to the beginning of the received message 39 (Ts 36 is fixed and known). In a preferred embodiment, distance measuring uses preferably a filter, said filter being software or hardware implemented, said filter being able to smooth some effects of measurement errors.

Fig. 5 describes the timing of a bi-directional range measurement, which is similar to the unidirectional measurement described in Fig. 4. A supervision unit SPU#1 61 sends a message Tm 63 to an MSU 62, said transmitted message being received 65 at the MSU after a propagation delay Td 64. An additional time, used to switch from receive to transmit mode Ts 66, is elapsed before the MSU transmits back a message Tm 67 which is synchronized to the received message 65, said transmitted message 67 being received 69 at the SPU#1 after a propagation delay Td 68, said propagation delay being normally very close to the previous propagation delay 64. Keeping synchronization with the received message 69, SPU#1 61, transmits a second message 71, after a switching time Ts 70. This second message is received 73 by the MSU after a propagation delay of Td 72.

Both SPU#1 and mobile/portable units, said mobile/portable unit being an MSU or an SRU, have information to calculate the distance between them.

In a preferred embodiment of the invention, when several SPU's are located in an area that they can communicate each other, said distance measuring process from several SPU's may be significantly improved.

The communication protocol used to measure distances allows to calculate the distance from several SPU's to a mobile/portable unit, said mobile/portable unit being an MSU or SRU, by only listening to the distance measuring process between one of said SPU's and said mobile/portable unit. In that way, mobile/portable unit location from multiple SPU's is performed by a single range measurement, thus the overhead of the network significantly

reduced and the distance is measured from all SPU's simultaneously thus minimizing the error in locating moving targets.

Referring to Fig. 6, there is shown a case where SPU#1 41 performs a range measurement with an MSU 42. Simultaneously a neighbor SPU 43 (SPU#2) listens to the messages between these two units.

A supervision unit SPU#1 41 sends a message Tm 44 to an MSU 42, said transmitted message being received 46 at the MSU after a propagation delay Td 45 and also received 48 at the neighbor SPU 43 after a different propagation delay Td1 47. An additional time, used to switch from receive to transmit mode Ts 49 is elapsed before the MSU transmits back a message Tm 50 which is synchronized to the received message 46, said transmitted message 50 being received 52 at SPU#1 after a propagation delay Td 51, said propagation delay being normally very close to the previous propagation delay 45, and received 54 at SPU#2 after a propagation delay Td2 53. As may be noted, SPU#2 does not transmit any message to the MSU. During this process, neighbor SPU#2 43 measures the time T1 55 from the received messages.

$$T1 = Tm + Ts + Td + (Td2 - Td1)$$

Then,

$$Td2 = T1 - Tm - Ts - Td + Td1$$

1. Td2 is the calculated propagation time between the MSU and neighbor SPU#2.
2. T1 is measured by the neighbor SPU#2 and transmitted to the center.
3. Td is calculated by SPU#1 and transmitted to the center.

4. T_m and T_s are fixed values.
5. T_{d1} is the propagation time between both SPU#1 and SPU#2, and may be calculated from the relative positions of the units or measured a priori by one of the units.

The measured time T_1 is sent to the center by any of the neighbor SPU's, and the center calculates T_{d2} from each neighbor to the MSU. As may be apparent to the skilled, knowing the propagation time T_{d2} , the distance from each SPU to the MSU is easily calculated and then using location information of the SPU's, said MSU location is also calculated.

In another preferred embodiment of the invention, each neighbor SPU will be able to calculate its distance from the target MSU, without the intervention of the center and without knowing T_d (the propagation time between SPU#1 and the target mobile/portable unit).

Referring to Fig. 7, there is shown a case where SPU#1 81 performs a range measurement with an MSU 82. Simultaneously a neighbor SPU 83 (SPU#2) listens to the messages between these two units.

A supervision unit SPU#1 81 sends a message T_m 84 to an MSU 82, said transmitted message being received 86 at the MSU after a propagation delay T_d 85 and also received 88 at the neighbor SPU 83 after a different propagation delay T_{d1} 87. An additional time, used to switch from receive to transmit mode T_s 89 is elapsed before the MSU transmits back a message T_m 90 which is synchronized to the received message 86, said transmitted message 90 being received 92 at SPU#1 after a propagation delay T_d 91, said propagation delay being normally very close to the previous propagation delay 85, and received 94 at SPU#2 after a propagation delay T_{d2} 93. Keeping synchronization with the received message 92, SPU#1 81,

transmits a second message 96, after a switching time T_s 95. This second message is received 98 by the MSU after a propagation delay of T_d 97 and also received 100 by the neighbor SPU#2 83 after a propagation delay T_{d1} 99.

As may be noted, also in this case SPU#2 does not transmit any message to the MSU. During this process, neighbor SPU#2 83 measures the time T_1 101 and T_2 102 from the received messages.

$$T_1 = T_m + T_s + T_d + (T_{d2} - T_{d1})$$

$$T_2 = T_m + T_s + T_d + (T_{d1} - T_{d2})$$

Then,

$$T_1 - T_2 = 2*(T_{d2} - T_{d1})$$

$$T_{d2} = (T_1 - T_2)/2 + T_{d1}$$

1. T_{d2} is the calculated propagation time between the MSU and neighbor SPU#2.
2. T_1 and T_2 are measured by the neighbor SPU#2.
3. T_m and T_s are fixed values.
4. T_{d1} is the propagation time between both SPU#1 and SPU#2, and may be calculated from the relative positions of the units or measured a priori by one of the units.

As previously described, this process can be performed simultaneously by many neighbors. Each neighbor SPU can calculate the distance to the mobile/portable unit, said calculation being done using the calculated propagation time T_{d2} and the propagation time between both SPU's (this time may be measured in advance or calculated based on the absolute SPU locations, as part of the network configuration). In addition, they can transmit the value of $T_1 - T_2$ to a center, which can then locate the mobile/portable unit.

In another preferred embodiment of the invention, the location process may be carried out by a local computer, which communicates with only a portion of the network.

In a preferred embodiment of the invention, an SPU and/or CTU have computing means and are connected to the Internet network. Said connection to the Internet network allows remote users having access to the Internet, to contact this unit (SPU or CTU) and perform different operations. As may be apparent to the skilled person contact with such a unit preferably requires some level of access protection (e.g. password), said access protection being defined for each level of access (e.g. Change parameters, location request, etc.). Said contact with an SPU or CTU may be used, but not limited to, for the functions described below:

1. SPU or CTU setup: A customer or permitted user may access a unit or group of units and change setup parameters. Said parameters may include, monitoring parameters, searching requests, units ID, etc. In addition said link may be used for download of new software versions, computerized maps or any other files requested for the SPU or CTU operation.
2. SPU control and status: SPU units may be remotely controlled allowing users or the communication center to request said SPU units to perform specific operations (e.g. monitoring, search, messaging, etc.), said operations normally related to mobile/portable units associated to said SPU.

In addition, to said control functions, said SPU may report to users or communication center status information, said status information preferably including operational parameters, usage counters used for customer billing, statistics, routing, etc., diagnostics results, history reports, etc. In a preferred embodiment, this link is also used to control,

said control including control of lights, video cameras, etc. or get status of the alarm system, said status including alarm status, video pictures, etc. In a similar way, a CTU may be also controlled and/or contacted to retrieve status information, said control or status information retrieval preferably limited to restricted personnel responsible of the system.

3. SPU or CTU query: Users or the communication center may request information from an SPU or CTU, said information being text information (e.g. messages, etc.), visual information (e.g. maps, pictures, etc.) or audio information (e.g. voice messages, etc.). For example, a user may access an SPU installed in his private home and get visual information about the location of his child, said child carrying an MSU. Said information may include distances to mobile/portable units, azimuth to said units, etc.

As will be apparent to the skilled person, any of the above query options are also possible directly with a communication center, said center being able to report information to authorized persons. Said center services may also include message delivery, tracking history, etc.

In a preferred embodiment of the invention, said Internet network link is used for message routing between SPU's, CTU's and centers, being said Internet link an effective alternative to other wireless or wired links.

The system described above, allows several fixed units, said fixed units being in contact with a mobile/portable unit to determine said mobile/portable position, based on range measurements.

In another preferred embodiment of the invention, a mobile portable unit, having range measurement means, measures the distance from several fixed units, said measurement being performed in a similar way as described before. Said measurements from several units and their absolute location are used by the mobile/portable unit, said mobile/portable unit being an SRU, to calculate its own position, said position data, either being calculated by a center or other unit and sent back to said mobile/portable unit or calculated by said mobile/portable unit itself, may be used to show said mobile/portable unit position on a digitized map displayed in said unit or in an attached display or in an attached terminal unit having said display, said location data also used by said mobile/portable unit to perform different functions including self-monitoring, tracking, guidance, speed and direction measurement, etc.

In a preferred embodiment of the invention, calibration of the network is performed in order to achieve better accuracy in the location process, and ranging or azimuth measurements. Said calibration process is preferably performed by measuring the range and/or azimuth to special units, said special units located in known places, said range or azimuth measurements compared to known values. Based on the difference between said measured values and said known values, offset values are calculated for each unit, said unit being an SPU or CTU, said offset values used to correct subsequent measurements of said SPU or CTU unit.

In a preferred embodiment, network operation may combine usage of Ground Positioning System (GPS) receivers, said GPS receivers allowing each SPU to calculate its own position with a high precision

Beside the basic functions of distance and azimuth measurement, location and messaging, the security system described in this invention inherently supports a variety of functions, said functions intended for different applications or uses. As will be apparent to the skilled person, the wireless communication channel used for security related messaging, may be used to transfer general two-way messages between any two elements of the network.

These messages include preferably destination and sender description as well as error correction codes, said error correction codes being adapted to the communication channel conditions. All non-broadcast messages are preferably acknowledged in order to ensure said messages are properly received while non-received messages or uncorrectable messages are preferably retried. For some type of messages a manual acknowledge of the user is requested in addition to the automatic system acknowledge, said manual acknowledge used to confirm user approval of a message being sent. In said mobile/portable units, manual acknowledge of the user is preferably performed by pressing a button (e.g. panic button). Messages are canned messages or free text messages, said canned messages preferably including a message code, and said free text messages comprising alphanumeric characters (e.g. ASCII coded) with or without encryption (to improve privacy and security). Received messages may also be used to control output lines and unit functions.

Emergency messages are preferably sent by a mobile/portable unit, said mobile/portable unit being an MSU or SRU, after a trigger from a distress event is sensed and/or generated by said mobile/portable unit. Said trigger type depends on the mobile/portable unit type while the emergency code or data being transmitted preferably varies according to the distress event. Typical examples of such events are:

1. Panic button pressed.
2. Alarm triggered (e.g. car alarm)
3. Sensor (shock, activity, medical sensors, etc.). Message data may include detailed description of the sensed data.

As previously explained, said emergency message is preferably sent first by said mobile/portable unit to its associated SPU unit(s). If after several retries, there is no response from said associated SPU unit(s), said MSU or SRU will broadcast said emergency message to any SPU and/or CTU unit being able to respond to said emergency message. SPU or CTU units, which received the message, will send a monitoring message to said mobile/portable unit, said monitoring message being the response to said broadcasted emergency message and also to measure the distance and optionally the azimuth, having said SPU or CTU unit direction finding means.

After said mobile/portable unit is acknowledged, said SPU or CTU will measure the distance and optionally the azimuth to said mobile/portable unit. Emergency messages received by an SPU or CTU will be routed to the center and/or other network elements, said emergency messages preferably including the MSU or SRU ID, emergency message code, additional message data, measured distance, time-of-day, SPU or CTU ID, etc.

In a preferred embodiment of the invention, mobile/portable units are also able to transmit control messages, said control messages being received by SPU units and said control messages converted to control signals, said control signals used to control home appliances or other electrical/electronic equipment, or said control information received sent to home units being able to communicate with said SPU, said communication being wired or wireless. As

will be apparent to the skilled person, said control messages may be also preferably acknowledged either by the SPU receiving the said message or by the target home unit, said home unit being able to send an acknowledgement message (through the SPU) or to generate an acknowledgement signal.

Monitoring messages are used to perform routine monitoring of MSU units by searcher units (SRU) or supervision units (SPU), said message type being transmitted either by an MSU or by an SRU or SPU and preferably addressed to associated units, while range and/or azimuth measurements being processed locally and if no special events are detected, no additional actions being performed. In other cases, a report will be preferably sent to the center or any other destination or a special notification will be given.

Text and coded messages are standard messages used to exchange any type of data between the network units, said messages having a format, which preferably differs according to the units exchanging the data and to the purpose of the message being sent.

Broadcast messages are sent and addressed to a plurality of units, said plurality of units being a group of units or all network units, said message having different types which several examples are following described.

1. Broadcast messages from the center to all SPU and/or CTU units. When relevant said messages are optionally sent to mobile/portable units (e.g. weather information, etc.)
2. Broadcast messages from an SPU or CTU to its neighbors.

3. Broadcast emergency message from an MSU or SRU to SPU's or CTU's located in the vicinity of said MSU or SRU unit.

In mobile/portable units or fixed units, messages received and/or transmitted are typically displayed on an alphanumeric display means, although they can be provided in other forms, e.g., audible form, said audible form being a synthesized or pre-recorded voice message generated from a message code received.

In other preferred embodiments of the invention, also a voice recognition function is added, allowing people to send emergency messages or any other messages without any button handling.

According to an additional preferred embodiment of the invention, the user of the SPU, CTU or the center are able to program sophisticated monitoring, tracking and searching functions, combining all the network, system and units capabilities, said functions comprising a plurality of programs intended for different applications or situations, said programs stored in said programmed units. Selection of one of said programs is preferably done easily using a control panel or an external device preferably attached to the SPU, said external device being a home alarm, telephone, personal computer, etc. For example an SPU may automatically initiate different monitoring functions or send messages to a single or group of persons according to the time-of-day, occurrence of events in programmed inputs, etc. and if required maintain a common and synchronized clock.

In another preferred embodiment of the invention, terminal units connected to a center or to concentrator units are used to retrieve specific information from the system, said terminals comprising computing and I/O means and said specific information comprising information about mobile/portable units (e.g. location, messages being sent and/or received, etc.).

According to a preferred embodiment of the invention, part or all of the network units, said network units including mobile/portable units (MSU and/or SRU), SPU, CTU and communication center include also a link to an existing wireless network, said wireless network being a pager network, cellular telephone network, etc.

Said wireless link may preferably be used for different purposes, such as:

1. Mobile/portable units may be called or paged using this link.
2. Transfer data or voice to/from said mobile/portable units.
3. Sync frames or control signals periodically transmitted by one of said networks, may be used for synchronization purposes by either mobile/portable units or fixed installed units, said synchronization allowing units to transmit or receive and pre-programmed times.
4. Sync frames or control signals periodically transmitted by one of said networks, may be used by mobile/portable units (MSU and/or SRU) or fixed units (SPU and/or CTU and/or communication center) to correct their internal local oscillator using said received signals from said networks as a reference signal, said local oscillator correction being done by comparing the local oscillator frequency or a derivative to said received signal frequency or a derivative, then modifying said local oscillator frequency to minimize the difference between said two frequencies.

Message routing within the network is preferably performed in one or combination of the following ways:

1. PSTN – Telephone line is used by an SPU or CTU to send emergency messages to the communication and service center, or by the communication and service center to send any type of information to one of the SPU's or CTU's.
2. Other wired communication channels – This may include ISDN networks, cable-TV networks, computer networks (e.g. Internet), etc.
3. Security Network wireless communication – Messages are routed from point to point by transmitting the message between neighbor SPU's and CTU's using the wireless channel.
4. Other wireless communication networks – This may include cellular networks, packet data networks, SMR and paging networks, etc.

In a preferred embodiment of the invention, commonly known routing algorithms are used to route messages within the network, said message routing between any two units in the network depending on unit capabilities and configuration, network topology, routing algorithms used, said routing algorithms using metrics as following described:

1. Number of hops from source to destination: Routing cost being based on the path with the shortest hop count.
2. Least Interference Routing: Routing cost being based on the number of radios that can overhear transmission on the link.

3. Max-Min Residual Capacity Routing: Routing cost being based on traffic dependent metric, said metric being a function of probability of successful transmission and interference.

As may be apparent to the skilled person, many other routing metrics may be used as an alternative or in combination to the metrics mentioned above.

In another preferred embodiment of the invention, the distance between nodes (SPU's and CTU's) is used for routing. The shortest distance to the target is used to decide which is the preferred neighbor to route the message to a specific destination.

Turning now to Fig. 8, there is shown an example of a network with a description of the routing tables from supervision units to a center. The network comprises a center 113, two concentrator units 112 (CTU#A and CTU#B) and five supervision units 111 (SPU#1-SPU#5). In the preferred embodiment described in this example, messages are routed to said center 113 through said concentrator units 112. Each supervision unit has a table 115, said table describing the preferred neighbor to reach a specific concentrator unit, said preferred neighbor being the shortest available path to said concentrator for said SPU unit. Distances between said network units 114 are shown for each pair of units that have direct communication, said network units being an SPU, CTU and a center having range measurement means, said range measurement performed using methods as described in Fig. 4 and Fig. 5. As previously explained, in this preferred embodiment, the preferred neighbor is selected by the shortest path to a specific concentrator. An SPU willing to send a message to the center 113, may select concentrator CTU#A or CTU#B or both to transfer the message. According to the CTU

selected, it will select the preferred neighbor. For example, if SPU#4 desires to send a message via CTU#A, it will select SPU#5 (the overall distance to CTU#A is 1500). As may be apparent to the skilled person, many other preferred embodiments may be implemented, including tables, which contain more than one preferred neighbor for each concentrator, additional parameters for the neighbor selection (e.g. azimuth), other routing metrics, etc. Neighbor tables including routing information are built during the initial network configuration and periodically updated.

In a preferred embodiment of the invention, initial configuration is obtained by broadcasting messages from each of the concentrator units to its neighbors said neighbors building a table including its distance from the concentrator and other parameters as defined by the routing algorithm. Said network configuration continues by propagating configuration messages between the network units, said units building a table including the best neighbor to one or more of said concentrators, said table optionally including more than one alternative for each concentrator, with priority to the best alternative. Once all nodes have built a table including at least one preferred neighbor to at least one concentrator, the network initial configuration is completed.

In another preferred embodiment of the invention, there are no concentrator units and all routing is performed directly to the center, said SPU units having a table with the preferred neighbor to the center.

As will be easily understood, network topology is dynamic and may change, as units are added, removed, or not operational. The network as described in this invention reconfigures itself periodically and updates the routing tables on each network unit, said network update

being preferably performed at specific intervals and/or as result of messages transmitted during normal operation.

In another preferred embodiment of the invention, each or part of the network units has routing tables to other units within the network (not only concentrators or center), thus allowing message transfer between any two units or selected units and said routing tables being built using prior art algorithms.

As will be apparent to the skilled person, an alternative to routing messages directly between any two points is routing them through concentrator units or even through the center, thus reducing the complexity of the routing algorithms.

Several networks of the invention may be operated independently, said networks being operated in different areas and being connected to one or more communication centers, said communication centers being able to communicate with one or more of said independent networks. Communication between two units of said independent networks, said units being mobile/portable or fixed installed, are preferably done either through a communication center or centers or either through other communication lines, said communication lines being wired (e.g. PSTN, computer networks, etc.) or wireless (e.g. cellular, SMR, etc.).

All the above description of preferred embodiments has been provided for the purpose of illustration, and is not intended to limit the invention in any way. Many modifications can be effected in the construction of the various units, many interfaces can be provided, and many

functions can be incorporated into the devices of the invention, all without exceeding the scope of the invention.

CLAIMS:

1. A security system comprising a plurality of home-based units provided with ranging means, said plurality of home-based units being in communication with a communication center, and a plurality of mobile/portable units related or unrelated to said home-based units, wherein each mobile/portable unit is capable of communicating with one or more home-based units located in its proximity.
2. A security system according to claim 1, further comprising direction finding means.
3. A security system according to claim 1, characterized in that it operates in a license-free band.
4. A security system according to any one of claims 1 to 3, wherein the home-based units are connected to, or integrated into, a home alarm unit, a computer or an electronic device.
5. A security system according to any one of claims 1 to 4, wherein the ranging means of the home-based units use spread spectrum techniques.
6. A security system according to any one of claims 1 to 5, wherein the home-based unit, the alarm unit, the computer unit or electronic device attached thereto are connected to a PSTN or other wired or wireless communication line suitable to allow said home-based unit to communicate with one or more communication centers, with other home-based units, or with any other destination, using said wired or wireless communication line.

7. A security system according to any one of claims 1 to 6, wherein the home-based unit comprises a wireless transceiver suitable to allow said home-based unit to communicate with other home-based units, with one or more concentrator units, with one or more communication centers, or with any other destination, using said wireless communication transceiver.

8. A security system according to any one of claims 1 to 7, wherein a central home-based unit is connected to multiple home alarm units and/or computer units and/or electronic devices, said central home-based unit being able to exchange data and optionally voice with one or more of said home-alarm units, computer units and electronic devices.

9. A security system according to any one of claims 1 to 8, wherein a concentrator unit comprises a wireless transceiver suitable to allow said concentrator unit to communicate with one or more home-based units, with other concentrator units, with one or more communication centers, or with any other destination, using said wireless communication transceiver.

10. A security system according to any one of claims 1 to 9, wherein the home-based unit is suitable to measure the distance and optionally the direction to a mobile/portable unit, and/or to another home-based unit, and/or to a concentrator unit and/or to a communication centers.

11. A security system according to claim 10, wherein the measured distance and the optionally measured direction are directly relayed to one or more communication centers, or relayed to

said communication center or centers through other home-based units and/or concentrator units.

12. A security system according to any one of claims 10 to 11, wherein the measured distance is used to perform perimeter monitoring of a mobile/portable unit and the optionally measured direction is used for said perimeter monitoring.

13. A security system according to any one of claims 10 to 12, wherein the perimeter monitoring range of a mobile/portable unit performed by a home-based unit, is expanded by using the perimeter monitoring functions of other home-based units located in the vicinity of said home-based units, said other home-based units being suitable to monitor said mobile/portable unit.

14. A security system according to any one of claims 10 to 13, wherein a communication center, a home-based unit, a mobile/portable unit, or a device attached or linked to any of the mentioned units are provided with requesting means to request one or more home-based units, related or unrelated to a mobile/portable unit, to search said mobile/portable unit.

15. A security system according to any one of claims 10 to 14, comprising circuitry associated with a mobile/portable unit for sending a message to a communication center or to a home-based unit, to perform the following steps:

- a. First transmission means, in said mobile/portable unit, to attempt to contact its related home-based unit(s), and second transmission means, associated with said contacted home-based unit(s) to transfer the message to its requested destination.

- b. Transmission means, provided in said mobile/portable unit, operable if said contact is unsuccessful, to broadcast a message to any home-based unit (related or unrelated), any concentrator unit, said units being suitable to be in contact with said mobile/portable unit, and to transfer the received message to its destination.

16. A security system according to any one of claims 1 to 15, wherein the location of a mobile/portable unit is determined by the measured or calculated distances from three or more home-based units to a said mobile/portable unit.

17. A security system according to claim 16, wherein the location of a mobile/portable unit is calculated by a communication center based on the measured or calculated distances from three or more home-based units to a said mobile/portable unit.

18. A security system according to any one of claims 16 to 17, wherein the location of a mobile/portable unit is calculated by a communication center based on the measured distances from a home-based unit to said mobile/portable unit and based on measurements performed by two or more home-based units which only listen to the distance measuring process between said home-based unit and said mobile/portable unit.

19. A security system according to any one of claims 16 to 18, wherein the distance from a home-based unit to a mobile/portable unit is calculated by said home-based unit which listen to the distance measurement process between another home-based unit to said mobile/portable unit and by knowing the distance between both home-based units.

20. A security system according to claim 16, wherein the location of a mobile/portable unit is calculated by a home-based unit or by a local computer connected to a home-based unit, based on the measured or calculated distances from three or more home-based units to said mobile/portable unit.

21. A security system according to any one of claims 16 to 20, wherein part or all of the home-based units used to locate the mobile/portable unit are replaced by other mobile/portable units, said mobile/portable units having at least ranging means and being in contact with said located mobile/portable unit.

22. A security system according to any one of claims 16 to 21, wherein the location of a mobile/portable unit is sent back to said mobile/portable unit.

23. A security system according to claim 16, wherein the location of a mobile/portable unit is calculated by the mobile/portable unit itself based on the measured distances from three or more home-based units to said mobile/portable unit, said distances being measured by said mobile/portable unit or measured or calculated by said home-based units and transferred back to said mobile/portable unit.

24. A security system according to any one of claims 22 to 23, wherein the location of a mobile/portable unit is used by said mobile/portable unit to perform self monitoring functions, guidance functions, speed and direction measurement, or the like operations.

25. A security system according to any one of claims 1 to 24, wherein more than one home-based unit perform the monitoring of a mobile/portable unit, said monitoring being performed simultaneously or not simultaneously by said more than one home-based units.

26. A security system according to any one of claims 1 to 25, wherein a home-based unit performs the monitoring of a mobile/portable unit, said monitoring being performed using parameters previously transferred by said mobile/portable unit or other mobile/portable unit to said home-based unit.

27. A security system according to any one of claims 1 to 26, wherein a group of two or more units selected from home-based units, concentrator units or communication centers, having wireless communication and ranging means, form a wireless network, said network being suitable to transfer messages preferably between any two units, using said wireless link.

28. A security system according to claim 27, wherein the network topology is dynamically configured, and/or self configured and/or periodically updated.

29. A security system according to any one of claims 27 to 28, wherein messages are routed within the network through a path which is the shortest configured path from the source unit to the destination unit.

30. A security system according to any one of claims 27 to 29, comprising terminal units having display means, suitable to communicate with the communication center, to send and retrieve information from said communication center.

31. A security system according to any one of claims 27 to 30, wherein part or all of the fixed and/or mobile/portable units also comprise a wireless link to another wireless network, said wireless network being a paging network, cellular telephone network, packet data network, or the like, said wireless link being suitable to call or page fixed or mobile/portable units, transfer data or voice to/from said fixed or mobile/portable units, to synchronize their operation and/or to correct the frequency of their internal frequency source.

32. A security system according to any one of claims 27 to 31, wherein independent wireless networks are linked to one or more common communication centers, said independent network being able to exchange messages between units in different networks through one of the common networks and/or through wired communication lines connecting said networks.

33. A security system according to any one of claims 1 to 32, wherein one or more home-based units, concentrators and communication centers are linked to the Internet network, said Internet network link being used to setup any of these units, and/or control them, said control being used to request different operations from said units and/or to control other units attached thereto, and/or request any kind of information, including operational status, billing information, measured range, calculated position, received messages, graphic information and audio or video information.

34. A method for providing security services to a person or moving unit, comprising providing a network consisting of a plurality of home-based units provided with ranging means, and optionally direction finding means, said plurality of home-based units being connectable to a

communication center, and providing said person or moving unit, related or unrelated to said home-based units, with means for communicating with one or more home-based units located in its proximity.

35. A method according to claim 34, wherein the person or moving unit is provided with transceiver means suitable to permit one or more home-based units to perform range measurement and optionally direction measurement operations thereon.

36. A method according to any one of claims 34 or 35, wherein a person in need of assistance, or a monitored object, transmits a signal through its mobile/portable unit to one or more home-based units located in his proximity, and wherein said one or more home-based units transmit(s) the signal received from said person or object, or a message representative of the signal received, to a communication center.

37. A method according to claim 36, wherein the home-based unit(s) perform a location procedure and transmit data indicative of the location of the person in need of assistance, or of the monitored object, to the communication center.

38. A method according to any one of claims 34 to 37, wherein the home-based unit(s) perform perimeter monitoring of a mobile/portable and optionally measure the direction for said perimeter monitoring.

39. A method according to any one of claims 34 to 38, wherein one or more home-based units, said home-based units being related or unrelated to a mobile/portable unit, perform a search of

a mobile/portable unit, said search operation originating from a communication center, a home-based unit, a mobile/portable unit, or a device attached or linked to any of the mentioned units.

40. A method according to any one of claims 34 to 39, wherein a mobile/portable unit sends a message to a communication center or to a home-based unit, performing the following steps:

- a. First, said mobile/portable tries to contact its related home-based unit or units and if so, said contacted home-based unit transfers the message to its requested destination.
- b. If said contact is unsuccessful, said mobile/portable unit broadcasts a message to any home-based unit (related or unrelated), any concentrator unit, said units being able to be in contact with said mobile/portable unit. The received message is transferred to its destination by one or more units, which contacted said mobile/portable unit.

41. A method according to any one of claims 34 to 40, wherein the location of a mobile/portable unit is determined by the measured or calculated distances from three or more home-based units to a said mobile/portable unit.

42. A method according to claim 41, wherein the location of a mobile/portable unit is calculated by a communication center based on the measured or calculated distances from three or more home-based units to a said mobile/portable unit.

43. A method according to any one of claims 41 to 42, wherein the location of a mobile/portable unit is calculated by a communication center based on the measured distances from a home-based unit to said mobile/portable unit and based on measurements performed by two or more home-based units which only listen to the distance measuring process between said home-based unit and said mobile/portable unit.

44. A method according to any one of claims 41 to 43, wherein the distance from a home-based unit to a mobile/portable unit is calculated by said home-based unit which listen to the distance measurement process between another home-based unit to said mobile/portable unit and by knowing the distance between both home-based units.

45. A method according to claim 41, wherein the location of a mobile/portable unit is calculated by a home-based unit or by a local computer connected to a home-based unit, based on the measured or calculated distances from three or more home-based units to said mobile/portable unit.

46. A method according to any one of claims 41 to 45, wherein part or all of the home-based units used to locate the mobile/portable unit are replaced by other mobile/portable units, said mobile/portable units having at least ranging means and being in contact with said located mobile/portable unit.

47. A method according to any one of claims 41 to 46, wherein the location of a mobile/portable unit is sent back to said mobile/portable unit.

48. A method according to claim 41, wherein the mobile/portable unit calculates its own location based on the measured distances from three or more home-based units to said mobile/portable unit, said distances being measured by said mobile/portable unit or measured or calculated by said home-based units and transferred back to said mobile/portable unit.

49. A method according to any one of claims 47 to 48, wherein the person holding a mobile/portable unit or an object attached to a mobile/portable unit use said unit to perform one or more operations, including self monitoring functions, guidance functions, speed and direction measurement, and the like.

50. A method according to any one of claims 33 to 49, wherein more than one home-based unit performs monitoring of a mobile/portable unit, said monitoring being performed simultaneously or non-simultaneously by said home-based units.

51. A method according to any one of claims 33 to 50, wherein a home-based unit performs monitoring of a mobile/portable unit, said monitoring being performed using parameters previously transferred by said mobile/portable unit or other mobile/portable unit to said home-based unit.

52. A method according to any one of claims 33 to 51, wherein messages between two or more fixed units selected from home-based units, concentrator units or communication centers, having wireless communication and ranging means, are routed through directly connected units, said units forming a wireless network, said network being suitable to transfer messages preferably between any two units, using said wireless link.

53. A method according to claim 52, wherein messages are routed within the network through a path, which is the shortest, configured path from the source unit to the destination unit.

54. A method according to any one of claims 52 to 53, wherein terminal units suitable to communicate with the communication center and provided with display means, are used to send and retrieve information from said communication center.

55. A method according to any one of claims 52 to 54, wherein calling or paging of fixed or mobile/portable units, transferring data or voice to/from said fixed or mobile/portable units, synchronizing their operation and/or correcting the frequency of their internal frequency source is performed by linking said mobile/portable units to another wireless network, said wireless network being a paging network, cellular telephone network, packet data network, and the like network.

56. A method according to any one of claims 52 to 55, wherein messages are exchanged between independent wireless networks linked to one or more common communication centers, said messages being exchanged through one of the common networks and/or through wired communication lines connecting said networks.

57. A method according to any one of claims 33 to 56, wherein the Internet network is used to setup, and/or control, and/or request any kind of information, including, but not limited to, operational status, billing information, measured range, calculated position, received

messages, graphic information and audio or video information, from one or more home-based units, concentrators and communication centers which are linked to said Internet network..

58. A concentrator unit suitable for use in a security system, said concentrator units being connectable to a communication center and to a plurality of home-based units and mobile/portable units, said concentrator units being adapted to concentrate the communication between home-based units and communication centers.

59. A concentrator unit according to claim 58, which is operable in a license-free band.

60. A concentrator unit according to claim 58 or 59, comprising ranging means.

61. A concentrator unit according to claim 58 or 60, comprising direction finding means.

62. A unit according to any one of claims 58 to 61, wherein a concentrator unit comprises a wireless transceiver suitable to allow said concentrator unit to communicate with one or more home-based units, with other concentrator units, with one or more communication centers, or with any other destination, using said wireless communication transceiver.

63. A home-based unit suitable for use in a security system monitoring, comprising ranging means, said home-based unit being connectable to a communication center, to concentrator units and to a plurality of mobile/portable units being related or unrelated to said home-based units.

64. A home-based unit according to claim 63, adapted to operate in a license-free band.

65. A home-based unit according to claim 63 or 64, comprising direction finding means.

66. A home-based unit according to any one of claim 63 to 65, said unit being connected to, or integrated into, a home alarm unit, a computer or an electronic device.

67. A unit according to any one of claims 63 to 66, wherein the range measurement is performed using spread spectrum techniques.

68. A unit according to any one of claims 63 to 67, wherein the antenna is internal or external to said unit.

69. A unit according to any one of claims 63 to 68, wherein a diversity antenna is used to improve the communication link between said unit and other fixed or mobile/portable units.

70. A unit according to any one of claims 63 to 69, wherein frequency hopping techniques are used to improve the communication link between said unit and other fixed or mobile/portable units.

71. A unit according to any one of claims 63 to 70, wherein said unit comprises audio means suitable to send or receive voice messages or reproduce sound alarms.

72. A unit according to any one of claims 63 to 71, wherein messages are transmitted including error correction codes, and/or encrypted.

73. A unit according to any one of claims 63 to 72, wherein home-based unit, the alarm unit, the computer unit or electronic device attached thereto is connected to a PSTN or other wired or wireless communication line suitable to allow said home-based unit to communicate with one or more communication centers, with other concentrator units, home-based units, or with any other destination, using said wired or wireless communication line.

74. A unit according to any one of claims 63 to 73, wherein the home-based unit comprises a wireless transceiver suitable to allow said home-based unit to communicate with other home-based units, with one or more concentrator units, with one or more communication centers, or with any other destination, using said wireless communication transceiver.

75. A unit according to any one of claims 63 to 74, wherein a home-based unit is connected to multiple home alarm units and/or computer units and/or electronic devices, said central home-based unit being suitable to exchange data and optionally voice with any of said home-alarm units, computer units and electronic devices.

76. A unit according to any one of claims 63 to 75, wherein the measured distance is used to perform perimeter monitoring of a mobile/portable and the optionally measured direction is used for said perimeter monitoring.

77. A home-based unit according to any one of claims 63 to 76, wherein the distance from a home-based unit to a mobile/portable unit is calculated by said home-based unit which listens to the distance measurement process between another fixed unit to said mobile/portable unit and by knowing the distance between both home-based units.

78. A unit according to any one of claims 63 to 77, wherein the location of a mobile/portable unit is calculated by a home-based unit or by a local computer connected to a home-based unit, based on the measured or calculated distances from three or more home-based units to said mobile/portable unit.

79. A unit according to any one of claims 63 to 78, wherein a home-based unit performs monitoring of a mobile/portable unit, said monitoring being performed using parameters previously transferred by said mobile/portable unit or other mobile/portable unit to said home-based unit.

80. A unit according to any one of claims 63 to 79, wherein a home-based unit is also a concentrator unit.

81. A unit according to any one of claims 63 to 80, wherein said unit has information about the network topology, said topology information being dynamically configured and/or periodically updated.

82. A unit according to any one of claims 63 to 81, wherein said units are adapted to route messages within the network through a path which is the shortest configured path from said unit to the destination unit.

83. A unit according to any one of claims 63 to 82, further comprising a wireless link to another wireless network, said wireless network being a paging network, cellular telephone network, packet data network, or the like, said wireless link being adapted to call or page said unit, transfer data or voice to/from said unit, synchronize its operation and/or to correct the frequency of its internal frequency source.

84. A unit according to any one of claims 63 to 83, which is connected to the Internet network, said Internet network link being used to setup said unit, and/or to control it, said control being used to request different operations from said unit and/or to control other units attached thereto, and/or to request any kind of information, including, but not limited to, operational status, billing information, measured range, calculated position, received messages, graphic information and audio or video information.

85. A unit according to any one of claims 63 to 84, comprising circuitry for using received messages to control home appliances connected to said unit, and for transmitting messages representative of the status of said home appliances.

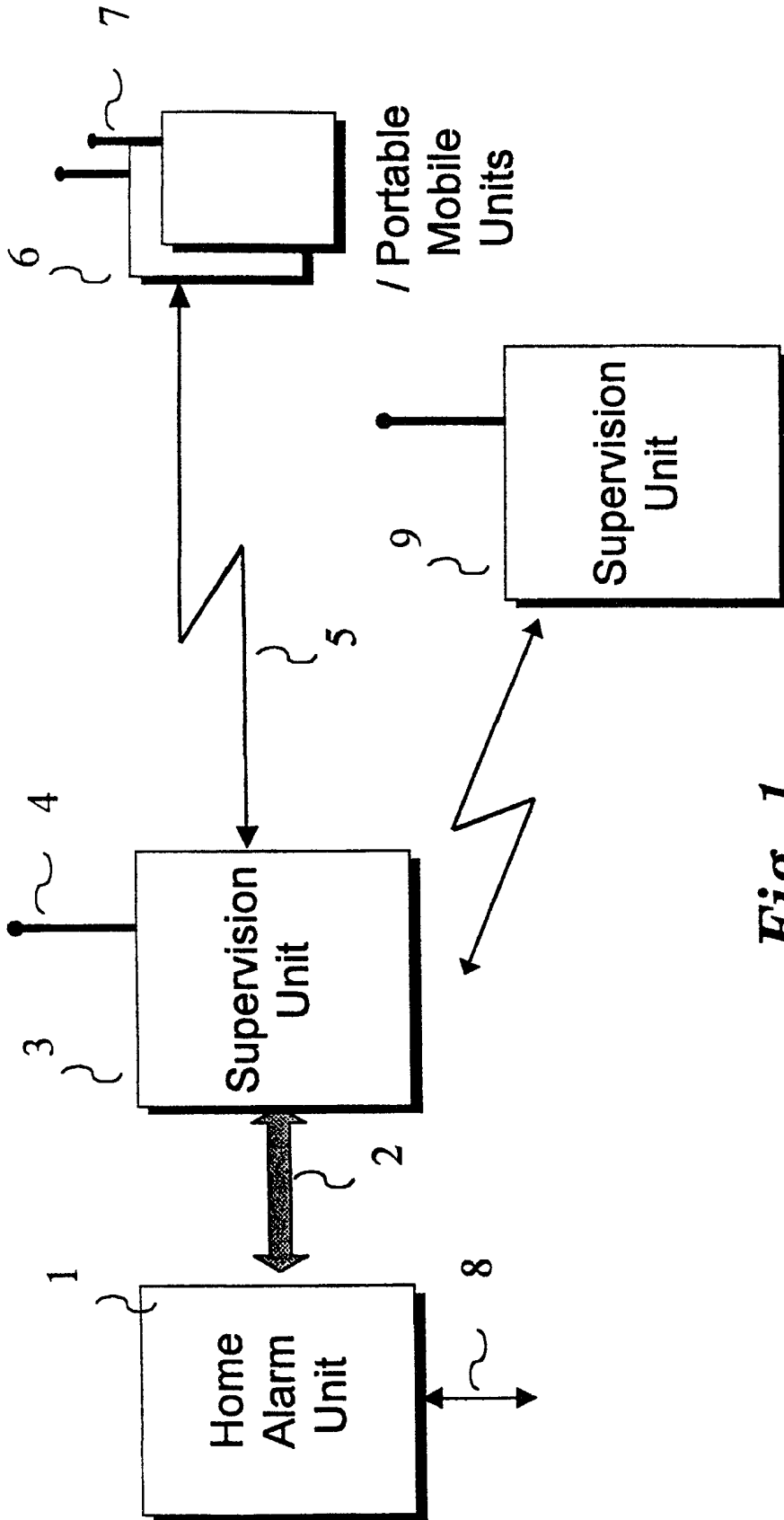

Fig. 1

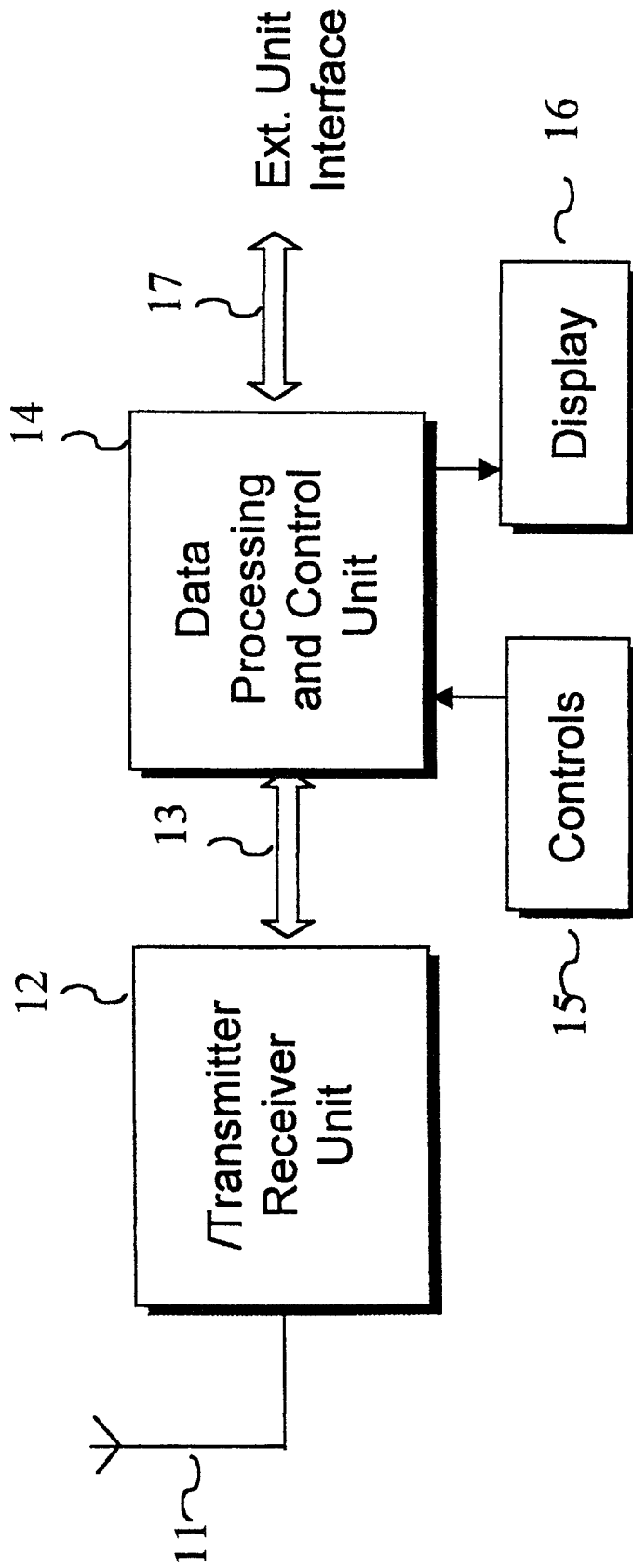

Fig. 2

3/8

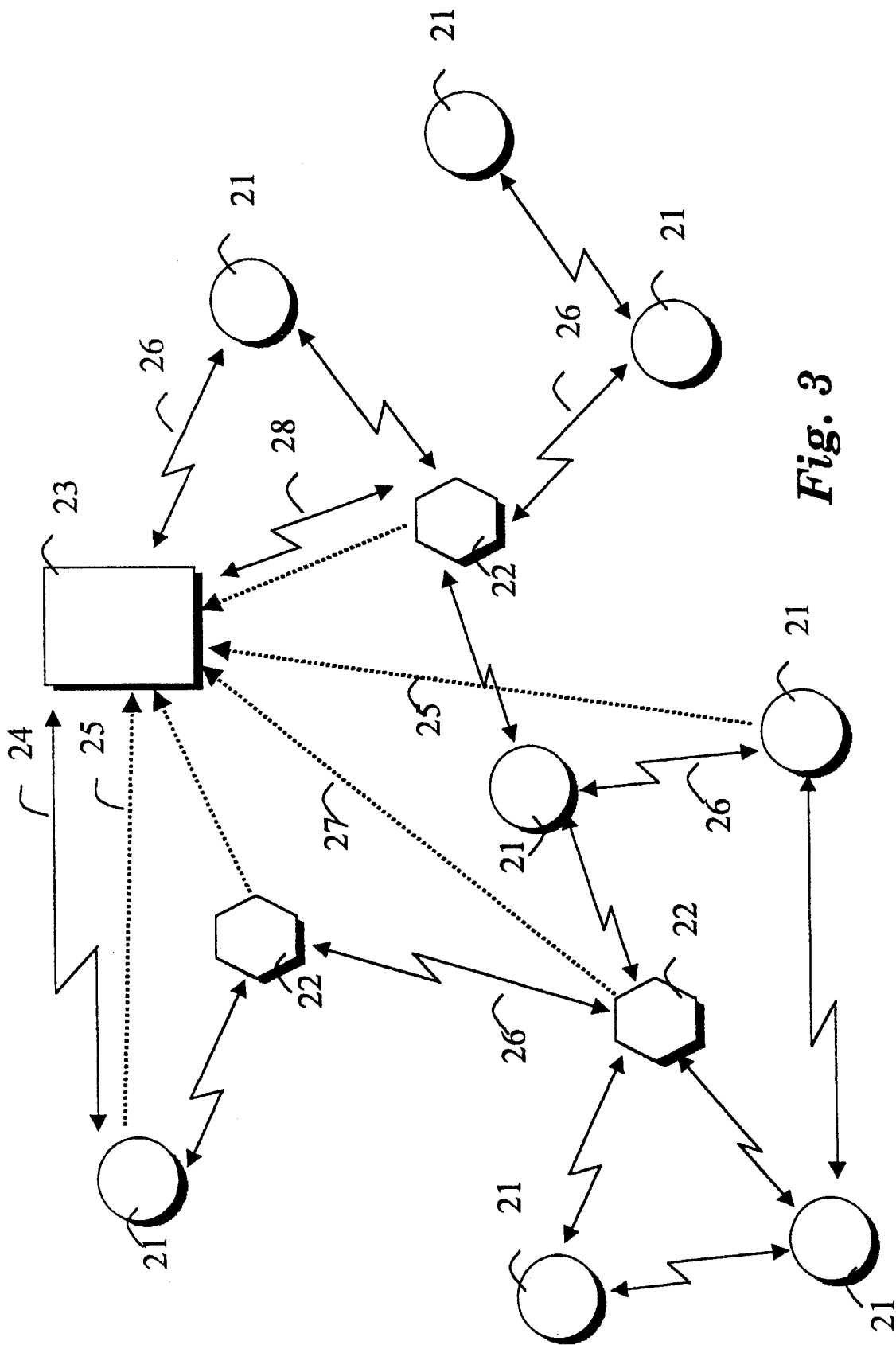

Fig. 3

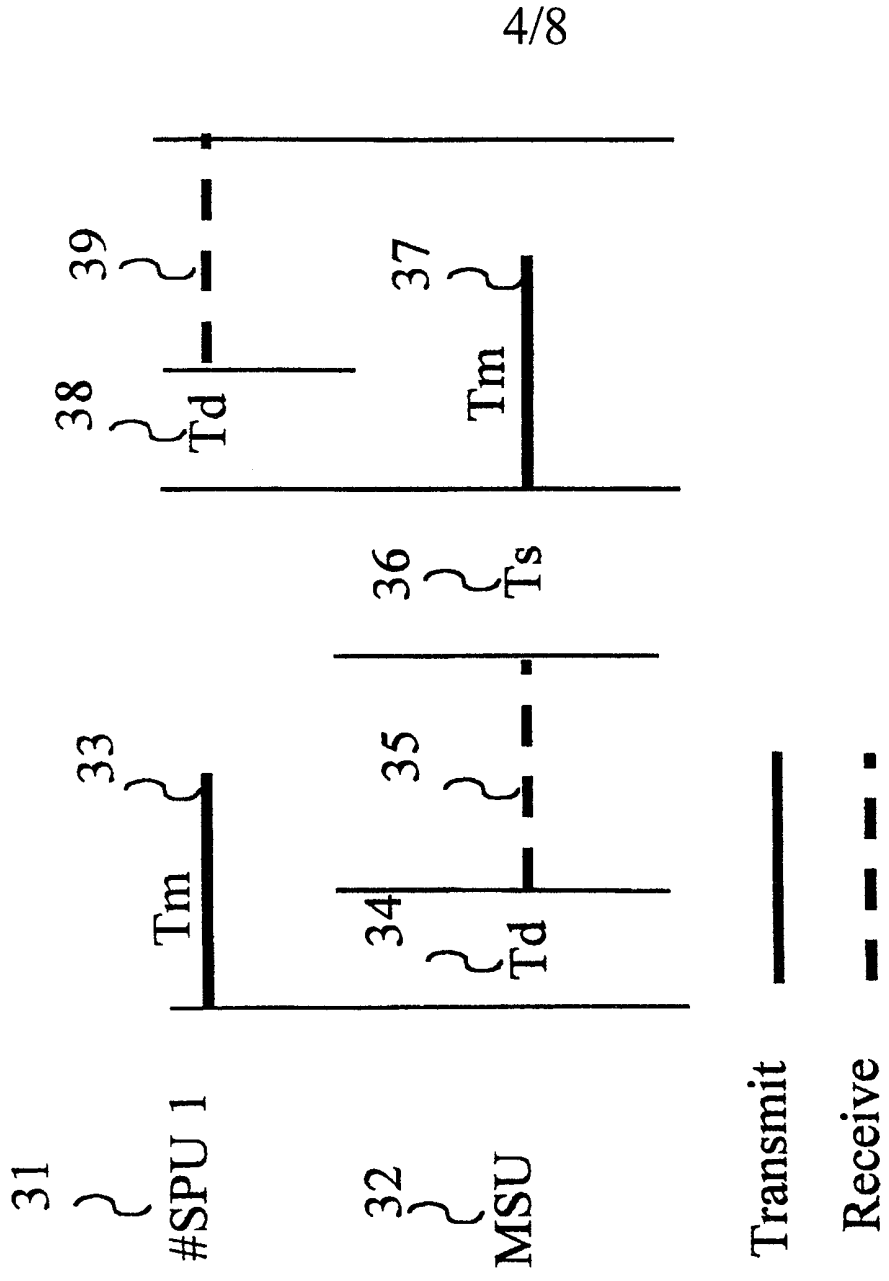

Fig. 4

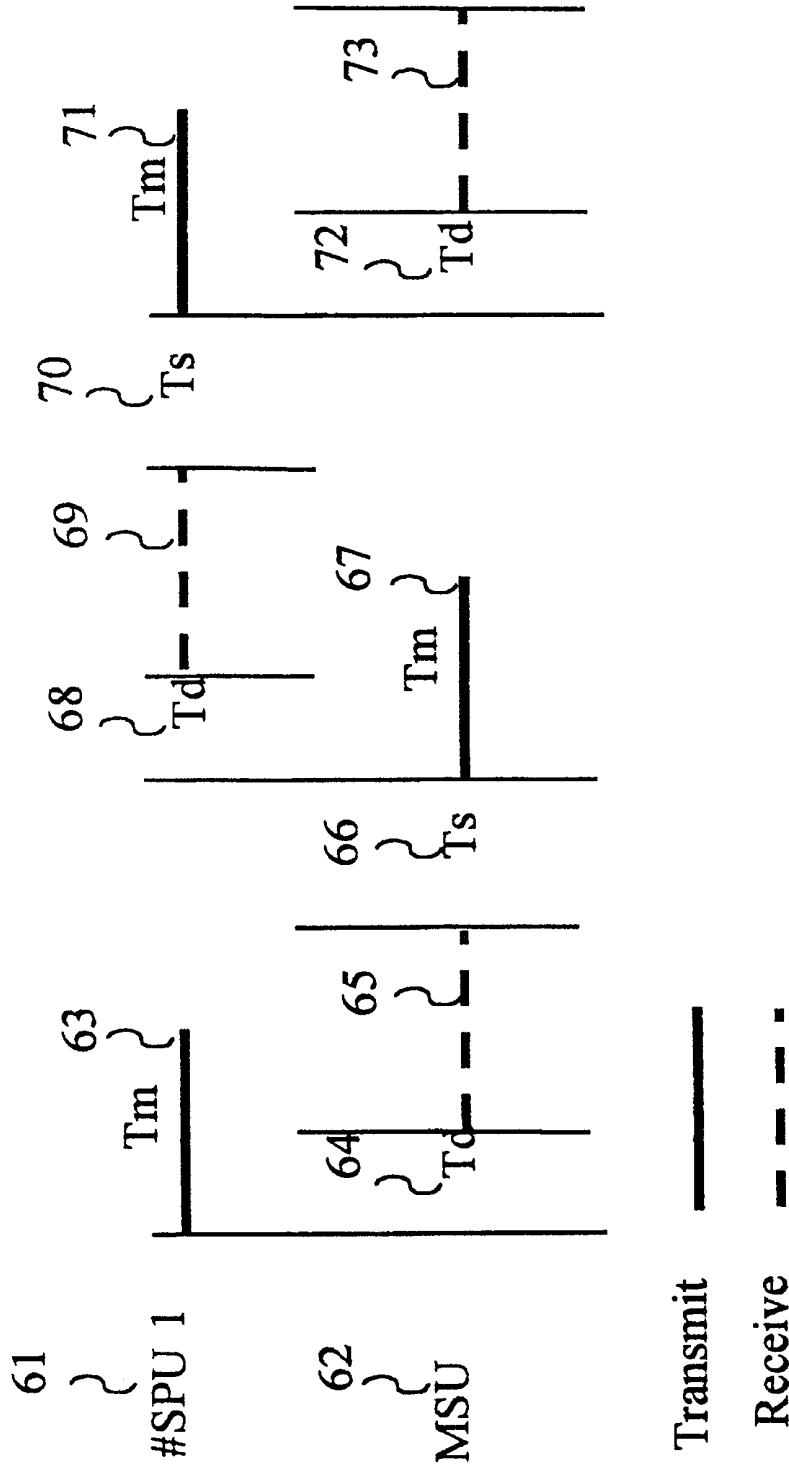

Fig. 5

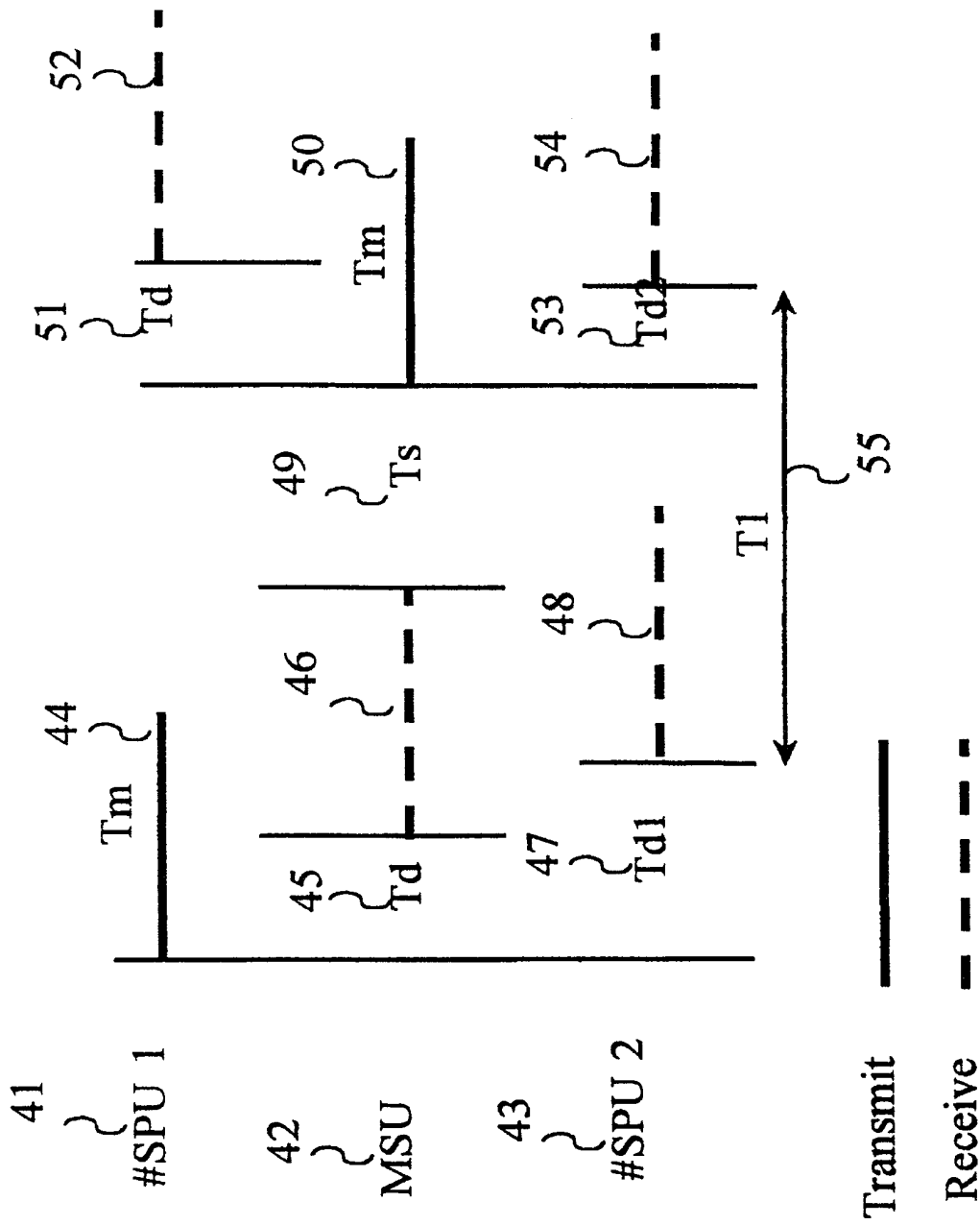

Fig. 6

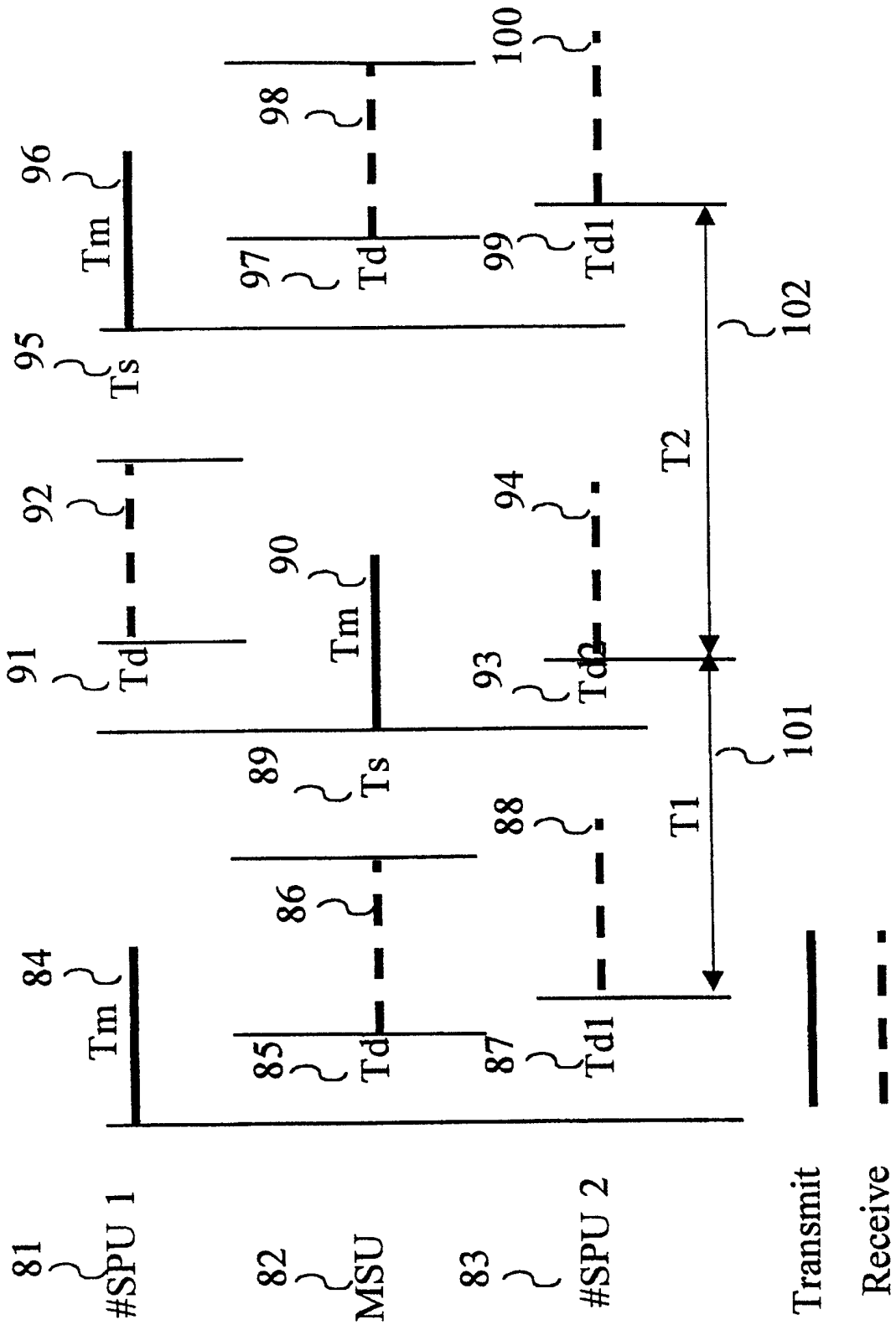

Fig. 7

INTERNATIONAL SEARCH REPORT

International Application No
PCT/IL 00/00108

A. CLASSIFICATION OF SUBJECT MATTER IPC 7 G08B21/00 G08B25/01				
According to International Patent Classification (IPC) or to both national classification and IPC				
B. FIELDS SEARCHED Minimum documentation searched (classification system followed by classification symbols) IPC 7 G08B G01S				
Documentation searched other than minimum documentation to the extent that such documents are included in the fields searched				
Electronic data base consulted during the international search (name of data base and, where practical, search terms used)				
C. DOCUMENTS CONSIDERED TO BE RELEVANT				
Category °	Citation of document, with indication, where appropriate, of the relevant passages	Relevant to claim No.		
X	WO 98 37932 A (TRAKUS INC) 3 September 1998 (1998-09-03) page 5, line 12 - line 26 page 7, line 3 - line 14 page 9, line 28 - line 29 page 14, line 21 - page 15, line 7 page 16, line 20 - line 21 claims 1,8-11,17	1-3,5,6, 10-12, 16-19, 25,27, 33-35, 41-44, 50,52, 57-61, 63-65, 67,68, 70,72, 74,77,84		
<input checked="" type="checkbox"/> Further documents are listed in the continuation of box C.				
<input checked="" type="checkbox"/> Patent family members are listed in annex.				
° Special categories of cited documents :				
<table style="width: 100%; border: none;"> <tr> <td style="width: 50%; border: none; vertical-align: top;"> *A* document defining the general state of the art which is not considered to be of particular relevance *E* earlier document but published on or after the international filing date *L* document which may throw doubts on priority claim(s) or which is cited to establish the publication date of another citation or other special reason (as specified) *O* document referring to an oral disclosure, use, exhibition or other means *P* document published prior to the international filing date but later than the priority date claimed </td> <td style="width: 50%; border: none; vertical-align: top;"> *T* later document published after the international filing date or priority date and not in conflict with the application but cited to understand the principle or theory underlying the invention *X* document of particular relevance; the claimed invention cannot be considered novel or cannot be considered to involve an inventive step when the document is taken alone *Y* document of particular relevance; the claimed invention cannot be considered to involve an inventive step when the document is combined with one or more other such documents, such combination being obvious to a person skilled in the art. *&* document member of the same patent family </td> </tr> </table>			*A* document defining the general state of the art which is not considered to be of particular relevance *E* earlier document but published on or after the international filing date *L* document which may throw doubts on priority claim(s) or which is cited to establish the publication date of another citation or other special reason (as specified) *O* document referring to an oral disclosure, use, exhibition or other means *P* document published prior to the international filing date but later than the priority date claimed	*T* later document published after the international filing date or priority date and not in conflict with the application but cited to understand the principle or theory underlying the invention *X* document of particular relevance; the claimed invention cannot be considered novel or cannot be considered to involve an inventive step when the document is taken alone *Y* document of particular relevance; the claimed invention cannot be considered to involve an inventive step when the document is combined with one or more other such documents, such combination being obvious to a person skilled in the art. *&* document member of the same patent family
A document defining the general state of the art which is not considered to be of particular relevance *E* earlier document but published on or after the international filing date *L* document which may throw doubts on priority claim(s) or which is cited to establish the publication date of another citation or other special reason (as specified) *O* document referring to an oral disclosure, use, exhibition or other means *P* document published prior to the international filing date but later than the priority date claimed	*T* later document published after the international filing date or priority date and not in conflict with the application but cited to understand the principle or theory underlying the invention *X* document of particular relevance; the claimed invention cannot be considered novel or cannot be considered to involve an inventive step when the document is taken alone *Y* document of particular relevance; the claimed invention cannot be considered to involve an inventive step when the document is combined with one or more other such documents, such combination being obvious to a person skilled in the art. *&* document member of the same patent family			
Date of the actual completion of the international search <p style="text-align: center; font-weight: bold;">31 May 2000</p>	Date of mailing of the international search report <p style="text-align: center; font-weight: bold;">08/06/2000</p>			
Name and mailing address of the ISA European Patent Office, P.B. 5818 Patentlaan 2 NL - 2280 HV Rijswijk Tel. (+31-70) 340-2040, Tx. 31 651 epo nl, Fax: (+31-70) 340-3016	Authorized officer <p style="text-align: center; font-weight: bold;">De la Cruz Valera, D</p>			

INTERNATIONAL SEARCH REPORT

International Application No
PCT/IL 00/00108

C.(Continuation) DOCUMENTS CONSIDERED TO BE RELEVANT		
Category *	Citation of document, with indication, where appropriate, of the relevant passages	Relevant to claim No.
X	<p>US 5 661 492 A (SHOAP STEPHEN DAVIS ET AL) 26 August 1997 (1997-08-26)</p> <p>column 1, line 38 - line 47 column 2, line 47 - line 60 column 3, line 12 - line 17 column 4, line 60 - line 65 column 8, line 4 - line 19</p>	<p>1,4,10, 12, 16-18, 25, 34-38, 41-43, 50,58, 63,76-78</p>
X	<p>US 5 218 344 A (RICKETTS JAMES G) 8 June 1993 (1993-06-08)</p> <p>column 8, line 34 - line 40 claims 1,2,7 figures 1,11 abstract</p>	<p>1,16-18, 27, 30-32, 34-39, 41,50, 52,58, 63,72, 74,76,83</p>

INTERNATIONAL SEARCH REPORT

Information on patent family members

International Application No

PCT/IL 00/00108

Patent document cited in search report	Publication date	Patent family member(s)	Publication date
WO 9837932 A	03-09-1998	AU 6442798 A EP 0969903 A	18-09-1998 12-01-2000
US 5661492 A	26-08-1997	NONE	
US 5218344 A	08-06-1993	NONE	