



- (51) International Patent Classification:  
*B65D 1/34* (2006.01)      *B65D 65/42* (2006.01)
- (21) International Application Number:  
PCT/US2016/065806
- (22) International Filing Date:  
9 December 2016 (09.12.2016)
- (25) Filing Language:  
English
- (26) Publication Language:  
English
- (30) Priority Data:  
62/266,084    11 December 2015 (11.12.2015)      US
- (71) Applicant: GRAPHIC PACKAGING INTERNATIONAL, INC. [US/US]; Law Department-9th Floor, 1500 Riveredge Parkway, Suite 100, Atlanta, GA 30328 (US).
- (72) Inventors: WALSH, Joseph, C.; 5532 La Plata Circle, Boulder, CO 80301 (US). SCHLAUCH, Michael, L.; 1475 Judson Drive, Boulder, CO 80305 (US). KASTANEK, Raymond, S.; 2627 Mustang Drive, Mead, CO 80542 (US).
- (74) Agent: CLAERBOUT, Andrew, N.; Womble Carlyle Sandridge & Rice LLP, P.O. Box 7037, Atlanta, GA 30357-0037 (US).
- (81) Designated States (unless otherwise indicated, for every kind of national protection available): AE, AG, AL, AM, AO, AT, AU, AZ, BA, BB, BG, BH, BN, BR, BW, BY,

BZ, CA, CH, CL, CN, CO, CR, CU, CZ, DE, DJ, DK, DM, DO, DZ, EC, EE, EG, ES, FI, GB, GD, GE, GH, GM, GT, HN, HR, HU, ID, IL, IN, IR, IS, JP, KE, KG, KH, KN, KP, KR, KW, KZ, LA, LC, LK, LR, LS, LU, LY, MA, MD, ME, MG, MK, MN, MW, MX, MY, MZ, NA, NG, NI, NO, NZ, OM, PA, PE, PG, PH, PL, PT, QA, RO, RS, RU, RW, SA, SC, SD, SE, SG, SK, SL, SM, ST, SV, SY, TH, TJ, TM, TN, TR, TT, TZ, UA, UG, US, UZ, VC, VN, ZA, ZM, ZW.

- (84) Designated States (unless otherwise indicated, for every kind of regional protection available): ARIPO (BW, GH, GM, KE, LR, LS, MW, MZ, NA, RW, SD, SL, ST, SZ, TZ, UG, ZM, ZW), Eurasian (AM, AZ, BY, KG, KZ, RU, TJ, TM), European (AL, AT, BE, BG, CH, CY, CZ, DE, DK, EE, ES, FI, FR, GB, GR, HR, HU, IE, IS, IT, LT, LU, LV, MC, MK, MT, NL, NO, PL, PT, RO, RS, SE, SI, SK, SM, TR), OAPI (BF, BJ, CF, CG, CI, CM, GA, GN, GQ, GW, KM, ML, MR, NE, SN, TD, TG).

**Declarations under Rule 4.17:**

- as to applicant's entitlement to apply for and be granted a patent (Rule 4.17(ii))
- as to the applicant's entitlement to claim the priority of the earlier application (Rule 4.17(iii))

**Published:**

- with international search report (Art. 21(3))

(54) Title: CONTAINER WITH ABSORPTION FEATURES

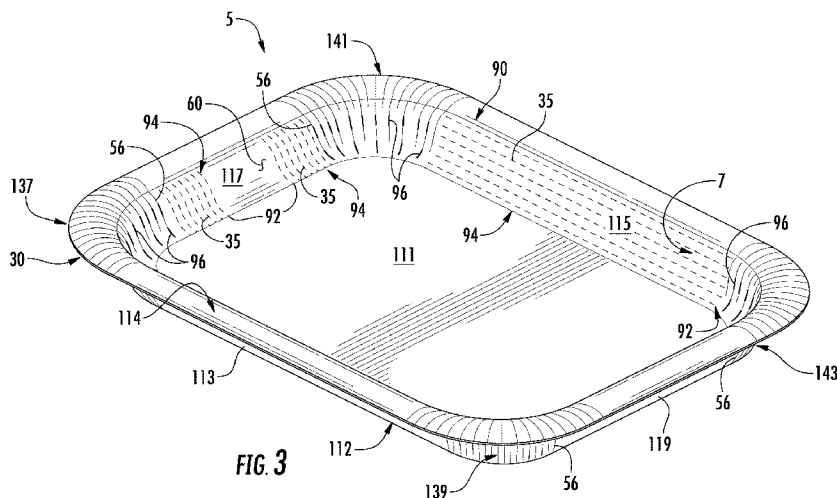

(57) Abstract: A container for holding a food product. The container can comprise a sidewall at least partially defining a cavity of the container, a flange extending from the sidewall, and a material comprising at least a base layer and a barrier layer on a face of the base layer. The flange and the sidewall each can comprise a portion of the material. The barrier layer can at least partially form an interior surface of the container, and the interior surface can at least partially extend along the cavity of the container. An absorption feature can extend in at least the barrier layer for allowing liquids to pass through the barrier layer and into the base layer.



**CONTAINER WITH ABSORPTION FEATURES****CROSS-REFERENCE TO RELATED APPLICATIONS**

[0001] This application claims the benefit of U.S. Provisional Patent Application No. 62/266,084, filed December 11, 2015.

**INCORPORATION BY REFERENCE**

[0002] The disclosure of U.S. Provisional Patent Application No. 62/266,084, filed December 11, 2015, is hereby incorporated by reference as if presented herein in its entirety and is incorporated by reference for all purposes.

**BACKGROUND OF THE DISCLOSURE**

[0003] The present disclosure relates to blanks, containers, trays, constructs, and various features to facilitate forming a container from a blank. More specifically, the disclosure is generally directed to a tray having features on an external surface with features for allowing moisture to reach an absorbent internal layer.

[0004] Prior art food trays such as are disclosed in U.S. Pat. No. 8,741,443 (the '443 patent) are known to include two layers of paperboard, a waterproof coating (e.g., polyethylene) on the inside surface of the tray for contact with the food product and a moisture proof coating (e.g., acrylic) on the bottom surface of the tray. Such trays have edges at the flange region that are uncoated and allow moisture to be absorbed into the paperboard layers at the edges of the flange. Once moisture is absorbed at the flange area of the tray, the flanges of the tray become stained and visibly unattractive to consumers and are structurally weakened by the high moisture absorption that is concentrated at the flange area. The entire contents of U.S. Pat. No. 8,741,443 are incorporated by reference herein for all purposes.

[0005] The tray or container of the present disclosure improves on the prior art food trays such as are disclosed in the '443 patent by including absorption features to prevent the moisture absorption in the flange area of the tray and the resulting staining and structural weakening of the tray.

**SUMMARY OF THE DISCLOSURE**

[0006] In general, one aspect of the disclosure is generally directed to a container for holding a food product. The container can comprise a sidewall at least partially defining a cavity of the container, a flange extending from the sidewall, and a material comprising at least a base layer and a barrier layer on a face of the base layer. The flange and the sidewall each can comprise a portion of the material. The barrier layer can at least partially form an interior surface of the container, and the interior surface can at least partially extend along the cavity of the container. An absorption feature can extend in at least the barrier layer for allowing liquids to pass through the barrier layer and into the base layer.

[0007] In another aspect, the disclosure is generally directed to a blank for forming a container for holding an article. The blank can comprise a sidewall portion for forming a sidewall at least partially defining a cavity of the container formed from the blank, a flange portion extending along the sidewall portion for forming a flange extending from the sidewall in the container formed from the blank, and a material comprising at least a base layer and a barrier layer on a face of the base layer. The flange portion and the sidewall portion each can comprise a portion of the material. The barrier layer can at least partially form an interior surface of the blank, and the interior surface can be for at least partially extending along the cavity when the container is formed from the blank. An absorption feature can extend in at least the barrier layer for allowing liquids to pass through the barrier layer and into the base layer.

[0008] In another aspect, the disclosure is generally directed to a method of forming a container from a blank. The method can comprise obtaining a blank comprising a material having at least a base layer, a barrier layer on a face of the base layer and at least partially forming an interior surface of the blank, and an absorption feature extending in at least the barrier layer for allowing liquids to pass through the barrier layer and into the base layer. The blank can comprise a sidewall portion and a flange portion each comprising a portion of the material. The method further can comprise forming a sidewall comprising at least the side portion of the blank. The sidewall can at least partially defining a cavity of the container with the interior surface at least partially extending along the cavity of the container. Also, the method can comprise forming a flange comprising at least the flange portion of the blank. The flange can extend from the sidewall.

[0009] Those skilled in the art will appreciate the above stated advantages and other advantages and benefits of various additional embodiments reading the following detailed description of the embodiments with reference to the below-listed drawing figures.

#### **BRIEF DESCRIPTION OF THE DRAWINGS**

[0010] According to common practice, the various features of the drawings discussed below are not necessarily drawn to scale. Dimensions of various features and elements in the drawings may be expanded or reduced to more clearly illustrate the embodiments of the disclosure.

[0011] Fig. 1 is an interior plan view of a blank used to form a tray according to a first exemplary embodiment of the disclosure.

[0012] Fig. 2 is a partial cross-sectional view of a material for the blank of Fig. 1 according to the first exemplary embodiment of the disclosure.

[0013] Fig. 2A is a partial cross-sectional view of an alternative material for the blank of Fig. 1.

[0014] Fig. 3 is a perspective view of the tray formed from the blank of Fig. 1 according to the first exemplary embodiment of the disclosure.

[0015] Fig. 4 is a perspective view showing the tray of Fig. 3 with a cover and containing a food product according to the first exemplary embodiment of the disclosure.

[0016] Fig. 5 is a perspective view of the tray of Fig. 4 after the food product has been removed according to the first exemplary embodiment of the disclosure.

[0017] Fig. 6 is an interior plan view of a blank used to form a tray according to second exemplary embodiment of the disclosure.

[0018] Fig. 7 is an interior plan view of a blank used to form a tray according to a third exemplary embodiment of the disclosure.

[0019] Corresponding parts are designated by corresponding reference numbers throughout the drawings.

**DETAILED DESCRIPTION OF THE EXEMPLARY EMBODIMENTS**

[0020] The present disclosure relates generally to various aspects of containers, constructs, trays, materials, packages, elements, and articles, and methods of making such containers, constructs, trays, materials, packages, elements, and articles. Although several different aspects, implementations, and embodiments are disclosed, numerous interrelationships between, combinations thereof, and modifications of the various aspects, implementations, and embodiments are contemplated hereby. In one illustrated embodiment, the present disclosure relates to a container or tray for holding food items or various other articles. However, in other embodiments, the container or tray can be used to hold other non-food containing articles or may be used for heating or cooking.

[0021] Fig. 1 illustrates a blank 3 that is used to form a container 5 (Figs. 3-5) having a flange 114 according to an exemplary embodiment of the disclosure. An interior surface 7 of the blank 3 is shown in Fig. 1. In the illustrated embodiment, the blank 3 is generally rectangular and has generally straight side edges 4a, 4b and straight end edges 6a, 6b with rounded corners 23, 25, 27, 29 extending between respective side edges and end edges. The blank 3 is for being press formed into the container 5 that, in the illustrated embodiment, is a generally rectangular tray. It is understood that the blank 3 can be press-formed into the container 5 by a forming tool (not shown), which can be similar to and have similar features and/or components as conventional forming tools such as are disclosed in U.S. Patent No. 8,534,460, the entire contents of which are incorporated herein by reference for all purposes. Also, the forming tool can have similar features and components such as the forming tool disclosed in U.S. Pat. No. 8,801,995, the entire contents of which are incorporated by reference for all purposes, or any other suitable forming tool assembly. The blank 3 and the container 5 could be alternatively shaped (e.g., circular, oval, rectangular, annular, irregular, etc.) and/or any suitable forming tool could be used to form the container 5 from the blank 3 without departing from the scope of this disclosure.

[0022] As shown in Fig. 1, the blank 3 has a longitudinal direction L1 and a lateral direction L2, with the side edges 4a, 4b extending in the longitudinal direction L1 and the end edges 6a, 6b extending in the lateral direction L2. The blank 3 has a central portion 11 (i.e., bottom panel portion or bottom portion), a sidewall portion 12 extending around the central portion, and a flange portion 14 extending along the sidewall portion 12. In one embodiment, the

central portion 11, the sidewall portion 12, and the flange portion 14 can be for forming a respective bottom panel, sidewall, and flange in the container 5 (Fig. 3). In the illustrated embodiment, the sidewall portion 12 can include two opposed side portions 13, 15 (i.e., side panel portions), and two opposed end portions 17, 19 (i.e., end panel portions). In one embodiment, four corner portions 37, 39, 41, 43 extend between (e.g., connect) adjacent respective side portions 13, 15 and end portions 17, 19. The flange portion 14 can include a marginal edge portion 30 (e.g., the outer edge 30) of the blank that includes the side edges 4a, 4b, the end edges 6a, 6b, and the corner edges 23, 25, 27, 29 (e.g., the outer edge 30 can extend along the perimeter of the blank 3). The flange portion 14 extends across the side portions 13, 15, the end portions 17, 19, and corner portions 37, 39, 41, 43.

**[0023]** In the illustrated embodiment, each of the corner portions 37, 39, 41, 43 can comprise a plurality of score lines 55 for forming pleats 56 in the container 5 (Fig. 3). As shown in Fig. 1, the score lines 55 can extend from the outer edge 30 of the blank 3 toward the central portion 11 of the blank, and some of the score lines can be longer than others. The score lines 55 could be otherwise shaped, arranged, configured, and/or positioned without departing from the disclosure. For example, the score lines 55 could be spaced apart from the edges of the blank and/or could extend into the central portion 11. In addition, each corner portion could include any suitable number of score lines. Further, the blank 3 could be generally circular, with score lines disposed around the entire circumference of the blank without departing from the disclosure. As shown in Fig. 1, the corner portions 37, 39, 41, 43 form a transition area between respective side portions 13, 15 and end portions 17, 19. Accordingly, the side portions 29, 31, the end portions 33, 35, and the corner portions 37, 39, 41, 43 can form the sidewall portion 12 that extends continuously around the central portion 11 in one embodiment. Further, in one exemplary embodiment, the flange portion 14, which includes the outer edges 4a, 23, 6a, 27, 4b, 29, 6b, 25, can extend continuously around the perimeter of the blank 3.

**[0024]** In the illustrated embodiment, the score lines 55 can facilitate the forming of corners 137, 139, 141, 143 from the respective corner portions 37, 39, 41, 43 during the press forming of the blank 3 into the tray 5. In one embodiment, the press forming of the blank 3 into the container 5 causes portions of the material 8 at the corners along the score lines 55 to overlap and form respective pleats 56 (shown schematically in Fig. 3).

[0025] In the illustrated embodiment, the blank 3 can be formed from a material 8 (e.g., a laminate material), as shown in Fig. 2. The material 8 can be similar to the material disclosed in the '443 patent in that the material 8 can comprise two layers of paperboard 76, 78 (broadly "base layer") attached by a layer of adhesive 84, a waterproof coating 80 on the face of the upper layer of paperboard 76, and a moisture proof coating 82 on the face of the lower layer of paperboard 78. As shown in Figs. 1 and 3, the waterproof coating 80 can form the interior surface 7 of the blank 3 and the container 5 and can comprise various suitable waterproof coatings such as polyethylene extrusion coating or other suitable waterproof coatings. In one exemplary embodiment, the waterproof coating 80 can be a polyethylene extrusion coating having 2.9% to 3.3% of the overall basis weight of the tray for protection against water and/or grease absorption. In general, the term "waterproof" is used in the present disclosure to refer to coating materials that prevent passage of all or substantially all water and/or grease and/or other fluids (e.g., from food products or other products) from passing through the coating material.

[0026] In the illustrated embodiment, the moisture proof coating 82 provides a moisture proof barrier on the bottom of the food tray and can be any suitable material such as water based acrylic aqueous coating or other suitable moisture proof coatings. In one exemplary embodiment, the moisture proof coating 82 can be a water-based acrylic aqueous coating having 1.4% to 1.5% of the overall basis weight of the tray. In general, the term "moisture proof" is used in the present disclosure to refer to coating materials that are resistant to moisture but not waterproof. For example, in one embodiment, the moisture proof coating 82 can generally prevent absorption of water or other liquids through the coating into the blank 3 or container 5 (e.g., if the container is set on a wet surface), yet can allow excess water to be expelled from the paperboard layers 76, 78 through the coating (e.g., during formation of the container from the blank).

[0027] In one embodiment, each of the waterproof coating 80 and the moisture proof coating 82 can be referred to as a barrier layer, in general. The material 8 could be otherwise shaped, arranged, configured, and/or positioned without departing from the disclosure. For example, the material 8 could include a single layer of paperboard or any suitable number of layers of paperboard, and/or one or more of the layers 76, 78 could be materials other than paperboard without departing from the disclosure. Further, the waterproof coating 80 could be any suitable coating to prevent water or moisture from passing directly from the interior surface 7

of the tray into the paperboard layers 76, 78. Also, the moisture proof coating 82 could be any suitable coating to that resists moisture absorption into the layer of material 8. Also, the moisture resistant coating 82 could be omitted or could be inherent in the properties of the bottom layer 78.

[0028] As shown in Fig. 1, the blank 3 can include an absorption feature 90. In the illustrated embodiment, the absorption feature 90 includes a plurality of perforations 35 (broadly “moisture absorption features”), which can be in the form of cuts, slits, apertures, openings, etc. in the waterproof coating 80 on the interior surface 7 of the tray 5 to allow moisture on the interior surface 7 of the tray 5 to pass through the waterproof coating 80 via the perforations and be absorbed into the paperboard layer 76. Broadly, as schematically shown in Fig. 2, the perforations 35 can be an absence of the coating material of the waterproof layer 80 (e.g., a void in the waterproof layer, which can be formed by forming partial cuts or piercings and/or by otherwise breaching the waterproof layer) to provide a passageway from the interior surface 7 to the paperboard layer 76 for the transmission of liquids (e.g., water, grease, and/or other fluids) from the interior surface to the paperboard layer. In the illustrated embodiment, the perforations 35 are in the form of elongate slits (Fig. 1). The perforations 35 can be formed by conventional cutting tools, or the perforations could be formed by applying the waterproof coating 80 as a patterned layer during the lamination of the layer 80. The patterned layer could include selective areas that are free from waterproof coating 80 to allow moisture to be absorbed by the paperboard layers 76, 78. The perforations 35 could be otherwise shaped, arranged, configured, and/or positioned without departing from the disclosure. For example, as shown in Fig. 2A, perforations 35' could extend into the material 8 at different depths (e.g., into one or both of the paperboard layers 76, 78). Perforations 35' that extend through the paperboard layer 76 and adhesive layer 84 could allow moisture to more readily be absorbed by the bottom paperboard layer 78. Alternatively or in addition, moisture can pass from the upper paperboard layer 76 through the adhesive layer and into the bottom paperboard layer 78 without extending the depth of the perforations into the paperboard layer 76. In addition, the perforations 35 could be alternatively shaped (e.g., curved cuts, circular or polygonal apertures or punctures, and/or other suitable shapes) or could be otherwise positioned (e.g., on the bottom panel 11) without departing from the disclosure. Further, the perforations 35 could be formed in the waterproof coating 80 of the container 5 after press forming the blank into the carton 5.

[0029] In one embodiment, the perforations 35 can be arranged in linear arrangements and/or in arrays. For example, as shown in Fig. 1, the perforations 35 can be aligned in a line of perforations 92, which can be repeated in the blank 3 to form an array of perforations 94. As shown in Fig. 1, the blank 3 can include a plurality of arrays of perforations 94, each extending in at least the sidewall portion 12. For example, the blank 3 can include an array of perforations 94 extending across each of the side panel portions 13, 15, wherein the lines of perforations 92 and the perforations 35 can be generally parallel to the side edges 4a, 4b. In addition, each of the end panel portions 17, 19 can include two arrays of perforations 94, wherein the lines of perforations 92 and the perforations 35 are generally perpendicular to the end edges 6a, 6b. As shown in Fig. 1, the absorption feature also can include perforations 96 (e.g., corner perforations) that are generally similar or identical to the perforations 35. The corner perforations 96 extend in the corners 37, 39, 41, 43 of the blank 3 and can be collinear with the respective score lines 55. Accordingly, when the container 5 is formed, the corner perforations 96 can be collinear with the pleats 56 (Fig. 3). In an alternative embodiment, the corner perforations 96 could be non-collinear with the score lines 55 and/or pleats 56.

[0030] In the illustrated embodiment, the perforations 35, 96 are all spaced apart from the outer edge 30 of the blank 3 by the flange portion 14 (e.g., the flange portion 14 is generally free of the perforations 35, 96), which can help prevent moisture from being absorbed into the paperboard layers 76, 78 at the flange (e.g., via the outer edge 30). Accordingly, the absorption feature 90 can help prevent the flange from being weakened or stained by moisture. The absorption feature 90, including the perforations 35, 96, the lines of perforations 92, and/or the arrays of perforations 94, could be otherwise shaped, arranged, configured, and/or positioned without departing from the disclosure. For example, the absorption feature 90 could include any suitable number of arrays of perforations 94 and/or lines of perforations 92. In addition, the perforations 35 could have different orientations in the lines and/or arrays and/or the lines of perforations 92 can have different orientations in the blank 3. Also, the perforations 35 could have different regular or irregular sizes and/or spacings. Further, the perforations 35 could extend in additional portions of the blank (e.g., the flange portion 14 and/or the central portion 11).

[0031] Figs. 3-5 show an embodiment of the disclosure comprising the container or tray 5 formed from the blank 3. The container 5 comprises a bottom wall or panel 111, side panels 113, 115, end panels 117, 119, and corners 137, 139, 141, 143 connecting respective adjacent

side panels 113, 115 and end panels 117, 119. In one embodiment, the side panels 113, 115, the end panels 117, 119, and the corners 137, 139, 141, 143 generally form a sidewall 112 that extends around the container 5 along the perimeter of the bottom wall 111. In the illustrated embodiment, the flange 114 extends outwardly from respective side panels 113, 115, the end panels 117, 119, and the corners 137, 139, 141, 143 (e.g., the flange 114 extends outwardly from the sidewall 112 of the container 5) and extends continuously around the perimeter of the container 5. In one embodiment, the bottom wall 111 is formed from the central portion 11 of the blank 3. In addition, the side panels 113, 115 can be formed from the respective side portions 13, 15 of the blank 3, the end panels 117, 119 can be formed from the respective end portions 17, 19 of the blank, and the corners 137, 139, 141, 143 can be formed from the respective corner portions 37, 39, 41, 43 of the blank (e.g., the sidewall 112 of the container 5 can be formed from the sidewall 12 portion of the blank 3) in the illustrated embodiment. As shown in Fig. 3, the container 5 has a cavity or interior space 60 that is defined by the bottom wall 111 and the sidewall 112 extending upwardly from the bottom wall 111. In the illustrated embodiment, the sidewall 112, including the side panels 114, 115, the end panels 117, 119, and the corners 137, 139, 141, 143, extends continuously around the cavity 60, and the interior surface 7 of the container 5 extends along the cavity 60 in the interior of the container 5. The container 5 is for holding and/or cooking and/or heating a food product F (Fig. 4) that is placed in the interior space 60 of the container.

[0032] As shown in Fig. 4, a package 150 can include the container 5, food items F (e.g., uncooked sausage and/or any other suitable food product), and a lid or cover C. In one embodiment, the cover C can comprise a packaging film that is a plastic layer used to preserve and/or protect a food item contained in the tray. Any plastic film, such as polystyrene, polyethylene, polypropylene, polyethylene terephthalate, polyvinylchloride, polyamide, and ethylene vinyl alcohol, or other suitable material, can be used. Any other suitable material can be used for forming the cover C that is sealed against an upper surface (e.g., the inner surface 7) of the flange 114. In one embodiment, the cover C can be sealed against the flange 114 by gluing, heat welding, ultrasonic welding, and/or any other suitable sealing method. In the illustrated embodiment, the cover C is a transparent or translucent film to allow visual inspection of the food product F in the package 150. The package 150, including the container 5, the cover C, and/or the food product F, could be otherwise shaped, arranged, configured, and/or positioned without departing from the disclosure. For example,

the food product F could have a different shape and/or orientation than shown by way of example in Fig. 4.

[0033] In the illustrated embodiment, the cover C and the waterproof coating 80 can cooperate to retain moisture in the package 150 from leaking out of the package. For example, the food product F can have excess water or grease that can collect in the cavity 60. Also, in one embodiment, the food product F could be frozen and water and/or other fluids could collect in the cavity 60 as the food product F is thawed. In certain occasions, the package 150 could be positioned on a surface (not shown) so that it is at least partially supported by the flange 114. In such circumstances, it can be desirable for the paperboard layers 76, 78 to remain dry (e.g., to not absorb liquids) in order to retain the structural integrity of the base layer (e.g., the flange could be weakened due to softening of the paperboard layers that have absorbed liquids). With the package 150 oriented on its side (e.g., as shown in Fig. 4), any liquids (e.g., water, grease, and/or other liquids) in the cavity 60 can move toward the flange 114, and any liquid that reaches the outer edge 30 could be absorbed by the paperboard layers 76, 78, which may be exposed at the edge 30 (e.g., as shown schematically in Fig. 2). Such absorption of liquids into the flange (e.g., via the outer edge 30) can soften the paperboard layers and weaken the flange 114. In addition, the absorption of the liquids into the paperboard in the flange can cause the flange to become deformed and/or stained, which may be unappealing to a user or potential buyer of the package 150. However, the absorption feature 90 can help prevent liquids from reaching the flange 114 and/or the outer edge 30. For example, the perforations 35, 96 in the sidewall 112 can allow liquids to pass through the waterproof coating 80 along the cavity 60 and be absorbed by the paperboard layer 76 in the interior of the container 5 before the liquids reach the flange 114. For example, liquid can collect on the side panel 113 when the package 150 is on its side as shown in Fig. 4, and the liquid can be absorbed into the paperboard layer 76 that extends along the side panel 113 via the perforations 35 in the waterproof layer 80 extending along the side panel 113. This absorption of the liquids via the perforations 35, 96 can form stains S (Fig. 5) and/or can cause softening, swelling, and/or other deformations of the material 8 at the side panel 113 in the proximity of the perforations 35, 96 where the liquids were absorbed. However, these stains S and/or deformations can be hidden or mostly hidden from a user by the food product F and/or other features, and a sufficient amount of the liquid can be absorbed before the liquid reaches the flange 114 since the absorption feature 90

extends over at least a portion of the surface area of the sidewall 112. In one embodiment, the stains S can indicate locations of high absorption of moisture into the paperboard layer 76

**[0034]** The perforations 35, 96 of the absorption feature 90 can be strategically located on the interior surface 7 of the container 5 to channel moisture that accumulates on interior surface 7 into the base layer or paperboard layer 76. The perforations 35, 96 can be located to absorb and dissipate moisture in specific locations of the container 5 so that the resulting stains S by the moisture being absorbed into the paperboard is hidden from view by the consumer, typically below the food product in the side panels 113, 115, end panels 117, 119, and/or corners 137, 139, 141, 143. Also, the location of the perforations 35, 96 can help keep the moisture from accumulating in the paperboard layers 76, 78 in the flange 114 so that the flange remains dry and provides rigidity and structural strength to the container 5. In some embodiments, the containers 5 are displayed in retail shelves in an angled or upright position supported in a display case on one of the side panels 113 and 115, and the perforations 35, 96 allow moisture to be absorbed into the paperboard before it flows over the interior surface of the flange 114 and reaches the edge 30 (Fig. 2) of the flange that can be uncoated with the waterproof coating 80 in one embodiment.

**[0035]** It is understood that the material 8 for the blank 3 can be formed by any suitable process such as disclosed in the '443 patent or any other process. The tray 5 can be formed from the blank 3 by press forming the container 5 by a forming tool or by any suitable process such as disclosed in the '443 patent or any other process. Also, the blank 3 and the container 5 could be alternatively shaped (e.g., circular, oval, rectangular, annular, irregular, etc.) without departing from the scope of this disclosure.

**[0036]** Fig. 6 is a plan view of a blank 203 for forming a container (not shown) according to a second embodiment of the disclosure. The second embodiment is generally similar to the first embodiment, except for variations noted and variations that will be apparent to one of ordinary skill in the art. Accordingly, similar or identical features of the embodiments have been given like or similar reference numbers. As shown in Fig. 6, the blank 203 can include an alternative absorption feature 290 with various arrays of perforations 294 having lines or perforations 292 of various orientations. In general, the lines of perforations 292 can be oblique with respect to the longitudinal direction L1 and the lateral direction L2 and to the side edges 4a, 4b and end edges 6a, 6b of the blank 203. In one exemplary embodiment, the

lines of perforations 292 and the perforations 35 can be oriented at approximately a 45 degree angle with respect to the longitudinal and lateral directions. Also, as shown in Fig. 6, the arrays of perforations 294 extend in the central portion 11 in addition to the sidewall portion 12 in order to provide additional surface area for absorbing liquids into the paperboard layer 76. In one embodiment, some or all of the lines of perforations 292 can be nonparallel with the direction(s) that the blank 203 or the container formed from the blank tends to fold in order to help prevent failure of the tray. For example, the tray could tend to fold along the grain direction of the paperboard and/or perpendicular to the grain direction and/or along the longitudinal and lateral directions of the tray. Accordingly, at least some of the perforations and/or the lines of perforations could be oriented to be oblique to these directions. Any of the perforations, lines, arrays, and/or other aspects of the absorption feature 290 could be omitted or could be otherwise shaped, arranged, configured, and/or positioned without departing from the disclosure.

[0037] Fig. 7 is a plan view of a blank 403 for forming a container (not shown) according to a third embodiment of the disclosure. The third embodiment is generally similar to the prior embodiments, except for variations noted and variations that will be apparent to one of ordinary skill in the art. Accordingly, similar or identical features of the embodiments have been given like or similar reference numbers. As shown in Fig. 7, the blank 403 can include an alternative absorption feature 490. In the illustrated embodiment, the absorption feature 490 can include two arrays of perforations 94 in the end portions 17, 19 that are similar or identical to the arrays of perforations 94 in the end portions 17, 19 of the blank 3 in Fig. 1. In addition, the absorption feature 490 can include an array of perforations 494a in each of the side portions 13, 15, wherein the lines of perforations 492a are aligned in an oblique direction with respect to the longitudinal direction L1 and the lateral direction L2. Further, the absorption feature 490 can include a number (e.g., five or any other suitable number) of arrays of perforations 494b extending the central portion 11 of the blank 403. Each of the arrays of perforations 494b can have lines of perforations 492b extending in the longitudinal direction L1. The absorption feature 490 could be omitted or could be otherwise shaped, arranged, configured, and/or positioned without departing from the disclosure. For example, the blank could include any suitable number of perforations in any suitable regular or irregular arrangement without departing from the disclosure.

- [0038] Any of the features of the various embodiments of the disclosure can be combined with, replaced by, or otherwise configured with other features of other embodiments of the disclosure without departing from the scope of this disclosure.
- [0039] Optionally, one or more portions of the blank or other constructs described herein or contemplated hereby may be coated with varnish, clay, or other materials, either alone or in combination. The coating may then be printed over with product advertising or other information or images. The blanks or other constructs also may be selectively coated and/or printed so that less than the entire surface area of the blank or substantially the entire surface area of the blank may be coated and/or printed.
- [0040] All dimensional information presented herein is intended to be illustrative of certain aspects, features, etc., of various embodiments of the disclosure, and is not intended to limit the scope of the disclosure. The dimensions of the blanks, containers, forming tools, features, or any other dimension, can be more or less than what is shown and described in this disclosure without departing from the scope of this disclosure and can be within the listed ranges of dimensions for each feature or outside the listed ranges of dimensions for each feature without departing from the scope of this disclosure.
- [0041] In accordance with the exemplary embodiments, the blanks may be constructed of paperboard of a caliper such that it is heavier and more rigid than ordinary paper. The blanks can also be constructed of other materials, such as cardboard, hard paper, or any other material having properties suitable for enabling the carton package to function at least generally as described above.
- [0042] The foregoing description illustrates and describes various embodiments of the present disclosure. As various changes could be made in the above construction without departing from the scope of the disclosure, it is intended that all matter contained in the above description or shown in the accompanying drawings shall be interpreted as illustrative and not in a limiting sense. Furthermore, the scope of the present disclosure covers various modifications, combinations, and alterations, etc., of the above-described embodiments. Additionally, the disclosure shows and describes only selected embodiments, but various other combinations, modifications, and environments are contemplated and are within the scope of the inventive concept as expressed herein, commensurate with the above teachings,

and/or within the skill or knowledge of the relevant art. Furthermore, certain features and characteristics of each embodiment may be selectively interchanged and applied to other illustrated and non-illustrated embodiments without departing from the scope of the disclosure.

## WHAT IS CLAIMED IS:

1. A container for holding a food product, the container comprising:
  - a sidewall at least partially defining a cavity of the container;
  - a flange extending from the sidewall;
  - a material comprising at least a base layer and a barrier layer on a face of the base layer, the flange and the sidewall each comprising a portion of the material, wherein the barrier layer at least partially forms an interior surface of the container, and the interior surface at least partially extends along the cavity of the container; and
  - an absorption feature extending in at least the barrier layer for allowing liquids to pass through the barrier layer and into the base layer.
2. The container of claim 1, wherein the flange comprises an edge, and the base layer is at least partially exposed at the edge.
3. The container of claim 2, wherein the absorption feature is spaced apart from the edge for allowing the liquids to pass through the barrier layer for absorption into the base layer at a location that is spaced apart from the edge.
4. The container of claim 3, wherein the absorption feature extends in at least the sidewall.
5. The container of claim 1, wherein the barrier layer is a waterproof layer, and a moisture-proof layer is disposed on an opposite surface of the container from the waterproof layer.
6. The container of claim 1, wherein the barrier layer comprises a waterproof material and the base layer comprises a water-absorbing material.
7. The container of claim 6, wherein the base layer comprises paperboard.
8. The container of claim 1, wherein the base layer comprises at least two layers of paperboard.

9. The container of claim 8, wherein the barrier layer is a waterproof layer disposed on a first layer of the at least two layers of paperboard, and a moisture-proof layer is disposed on a second layer of the at least two layers of paperboard, opposite to the waterproof layer.
10. The container of claim 1, wherein the absorption feature comprises a plurality of voids in the barrier layer.
11. The container of claim 10, wherein the plurality of voids comprises a line of voids, the voids of the line of voids extending in a linear arrangement in the sidewall.
12. The container of claim 11, wherein the line of voids is generally parallel to the flange.
13. The container of claim 12, wherein the line of voids is a first line of voids, the plurality of voids further comprises a second line of voids extending in the sidewall, the second line of voids extending generally perpendicular to the flange.
14. The container of claim 11, wherein the line of voids is generally perpendicular to the flange.
15. The container of claim 1, wherein the sidewall comprises a side panel and an end panel that is generally perpendicular to the side panel, the absorption feature comprises a first plurality of voids extending in the side panel and a second plurality of voids extending in the end panel.
16. The container of claim 15, wherein the side panel is a first side panel and the end panel is a first end panel, the sidewall comprises a second side panel disposed generally opposite to the first side panel and a second end panel disposed generally opposite to the first end panel, and the absorption feature further comprises a third plurality of voids extending in the second side panel and a fourth plurality of voids extending in the second end panel.
17. The container of claim 16, wherein the sidewall further comprises a first corner connecting the first side panel to the first end panel, a second corner connecting the first side

panel to the second end panel, a third corner connecting the second side panel to the first end panel, and a fourth corner connecting the second side panel to the second end panel.

18. The container of claim 17, wherein the flange extends along each of the first side panel, the second side panel, the first end panel, the second end panel, the first corner, the second corner, the third corner, and the fourth corner of the sidewall.

19. The container of claim 15, wherein the side panel and the end panel of the sidewall are connected by a corner, and the container further comprises a plurality of pleats extending in at least the corner of the sidewall.

20. The container of claim 19, wherein absorption feature further comprises a third plurality of voids, each void of the third plurality of voids being generally collinear with a respective pleat of the plurality of pleats.

21. The container of claim 1, further comprising a bottom panel, wherein the sidewall extends at least partially along a perimeter of the bottom panel, and the absorption feature extends in at least the bottom panel.

22. The container of claim 1, further comprising a cover at least partially in face-to-face contact with the flange.

23. The container of claim 22, wherein the cover extends over and covers the interior surface of the cavity.

24. The container of claim 1, further comprising a plurality of pleats extending in at least a portion of at least the sidewall, wherein the absorption feature comprises a plurality of voids in the barrier layer, and the voids of the plurality of voids are generally collinear with respective pleats of the plurality of pleats.

25. In combination, the container of claim 1 and a food item, wherein the food item is disposed in the cavity.

26. A blank for forming a container for holding a food product, the blank comprising:
- a sidewall portion for forming a sidewall at least partially defining a cavity of the container formed from the blank;
  - a flange portion extending along the sidewall portion for forming a flange extending from the sidewall in the container formed from the blank;
  - a material comprising at least a base layer and a barrier layer on a face of the base layer, the flange portion and the sidewall portion each comprising a portion of the material, wherein the barrier layer at least partially forms an interior surface of the blank, and the interior surface is for at least partially extending along the cavity when the container is formed from the blank; and
  - an absorption feature extending in at least the barrier layer for allowing liquids to pass through the barrier layer and into the base layer.
27. The blank of claim 26, wherein the flange portion comprises an edge, and the base layer is at least partially exposed at the edge.
28. The blank of claim 27, wherein the absorption feature is spaced apart from the edge for allowing the liquids to pass through the barrier layer for absorption into the base layer at a location that is spaced apart from the edge.
29. The blank of claim 28, wherein the absorption feature extends in at least the sidewall portion.
30. The blank of claim 26, wherein the barrier layer is a waterproof layer, and a moisture-proof layer is disposed on an opposite surface of the blank from the waterproof layer.
31. The blank of claim 26, wherein the barrier layer comprises a waterproof material and the base layer comprises a water-absorbing material.
32. The blank of claim 31, wherein the base layer comprises paperboard.
33. The blank of claim 26, wherein the base layer comprises at least two layers of paperboard.

34. The blank of claim 33, wherein the barrier layer is a waterproof layer disposed on a first layer of the at least two layers of paperboard, and a moisture-proof layer is disposed on a second layer of the at least two layers of paperboard, opposite to the waterproof layer.

35. The blank of claim 26, wherein the absorption feature comprises a plurality of voids in the barrier layer.

36. The blank of claim 35, wherein the plurality of voids comprises a line of voids, the voids of the line of voids extending in a linear arrangement in at least the sidewall portion.

37. The blank of claim 36, wherein the line of voids is generally parallel to the flange portion.

38. The blank of claim 37, wherein the line of voids is a first line of voids, the plurality of voids further comprises a second line of voids extending in at least the sidewall portion, the second line of voids extending generally perpendicular to the flange portion.

39. The blank of claim 36, wherein the line of voids is generally perpendicular to the flange portion.

40. The blank of claim 26, wherein the sidewall portion comprises a side portion and an end portion that is generally perpendicular to the side portion, the absorption feature comprises a first plurality of voids extending in the side portion and a second plurality of voids extending in the end portion.

41. The blank of claim 40, wherein the side portion is a first side portion and the end portion is a first end portion, the sidewall portion comprises a second side portion disposed generally opposite to the first side portion and a second end portion disposed generally opposite to the first end portion, and the absorption feature further comprises a third plurality of voids extending in the second side portion and a fourth plurality of voids extending in the second end portion.

42. The blank of claim 41, wherein the sidewall portion further comprises a first corner portion connecting the first side portion to the first end portion, a second corner portion connecting the first side portion to the second end portion, a third corner portion connecting the second side portion to the first end portion, and a fourth corner portion connecting the second side portion to the second end portion.

43. The blank of claim 42, wherein the flange portion extends along each of the first side portion, the second side portion, the first end portion, the second end portion, the first corner portion, the second corner portion, the third corner portion, and the fourth corner portion of the sidewall portion.

44. The blank of claim 40, wherein the side portion and the end portion of the sidewall portion are connected by a corner portion, and the blank further comprises a plurality of score lines extending in at least the corner portion of the sidewall portion.

45. The blank of claim 44, wherein absorption feature further comprises a third plurality of voids, each void of the third plurality of voids being generally collinear with a respective score line of the plurality of score lines.

46. The blank of claim 26, further comprising a central portion for forming a bottom wall when the container is formed from the blank, wherein the sidewall portion extends at least partially along a perimeter of the central portion, and the absorption feature extends in at least the central portion.

47. The blank of claim 26, further comprising a plurality of score lines for forming a plurality of pleats when the container is formed from the blank, wherein the plurality of score lines extends in at least a portion of at least the sidewall portion, the absorption feature comprises a plurality of voids in the barrier layer, and the voids of the plurality of voids are generally collinear with respective score lines of the plurality of score lines.

48. A method of forming a container, the method comprising:

obtaining a blank comprising a material having at least a base layer, a barrier layer on a face of the base layer and at least partially forming an interior surface of the blank, and an

absorption feature extending in at least the barrier layer for allowing liquids to pass through the barrier layer and into the base layer, wherein the blank comprises a sidewall portion and a flange portion each comprising a portion of the material;

forming a sidewall comprising at least the side portion of the blank, the sidewall at least partially defining a cavity of the container with the interior surface at least partially extending along the cavity of the container; and

forming a flange comprising at least the flange portion of the blank, the flange extending from the sidewall.

49. The method of claim 48, wherein the flange comprises an edge, the base layer is at least partially exposed at the edge, and the absorption feature is spaced apart from the edge for allowing the liquids to pass through the barrier layer for absorption into the base layer at a location that is spaced apart from the edge.

50. The method of claim 48, wherein the barrier layer is a waterproof layer, and a moisture-proof layer is disposed on an opposite surface of the container from the waterproof layer.

51. The method of claim 48, wherein the barrier layer comprises a waterproof material and the base layer comprises paperboard.

52. The method of claim 48, wherein the base layer comprises at least two layers of paperboard, the barrier layer is a waterproof layer disposed on a first layer of the at least two layers of paperboard, and a moisture-proof layer is disposed on a second layer of the at least two layers of paperboard, opposite to the waterproof layer.

53. The method of claim 48, wherein the absorption feature comprises a plurality of voids in the barrier layer.

54. The method of claim 48, wherein the forming the sidewall comprises forming a side panel and an end panel that is generally perpendicular to the side panel, the absorption feature comprises a first plurality of voids extending in the side panel and a second plurality of voids extending in the end panel.

55. The method of claim 54, wherein the side panel and the end panel of the sidewall are connected by a corner, the blank further comprises a plurality of score lines extending in at least a portion of the sidewall portion, the absorption feature further comprises a third plurality of voids, each void of the third plurality of voids being generally collinear with a respective score line of the plurality of score lines, the forming the sidewall comprises forming a plurality of pleats along the plurality of score lines, and the plurality of pleats extend in at least the corner.

56. The method of claim 48, further comprising disposing a food product in the cavity of the container and attaching a cover at least partially in face-to-face contact with the flange.



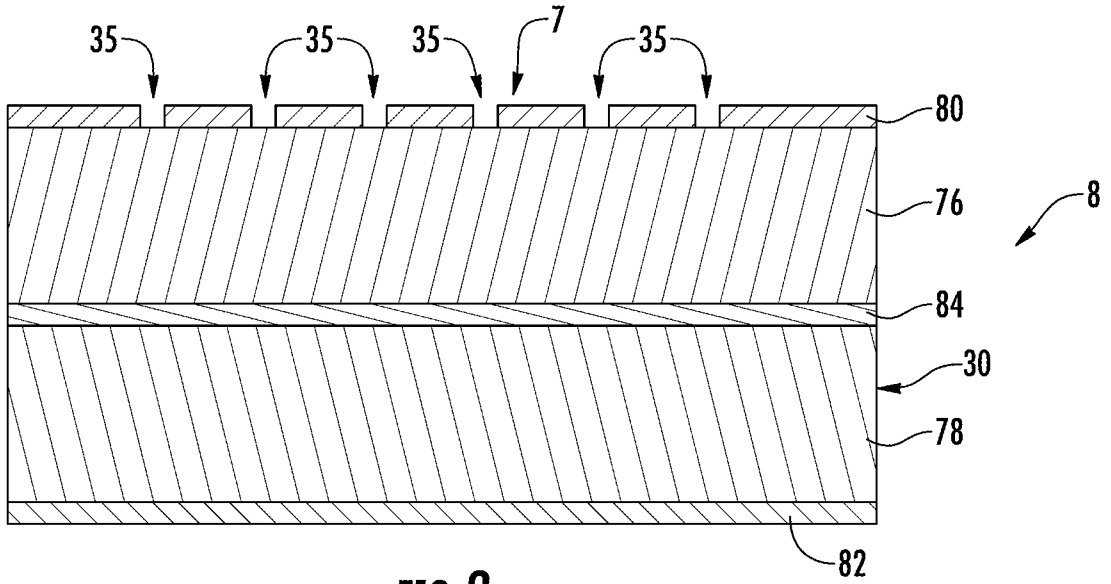

FIG. 2

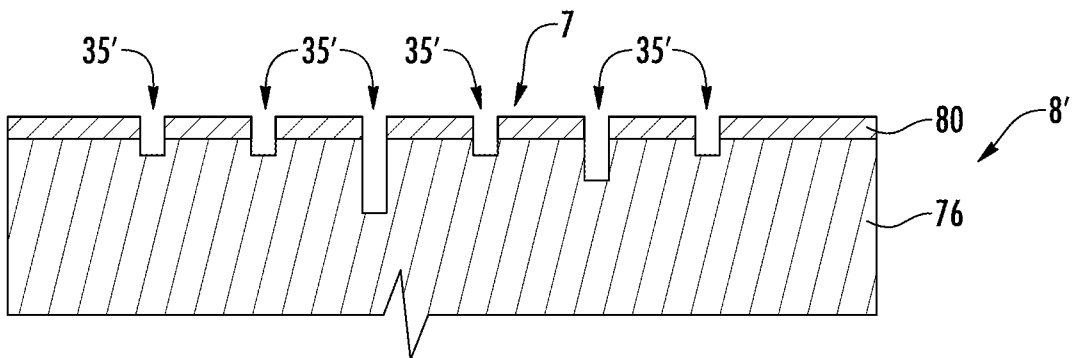

FIG. 2A

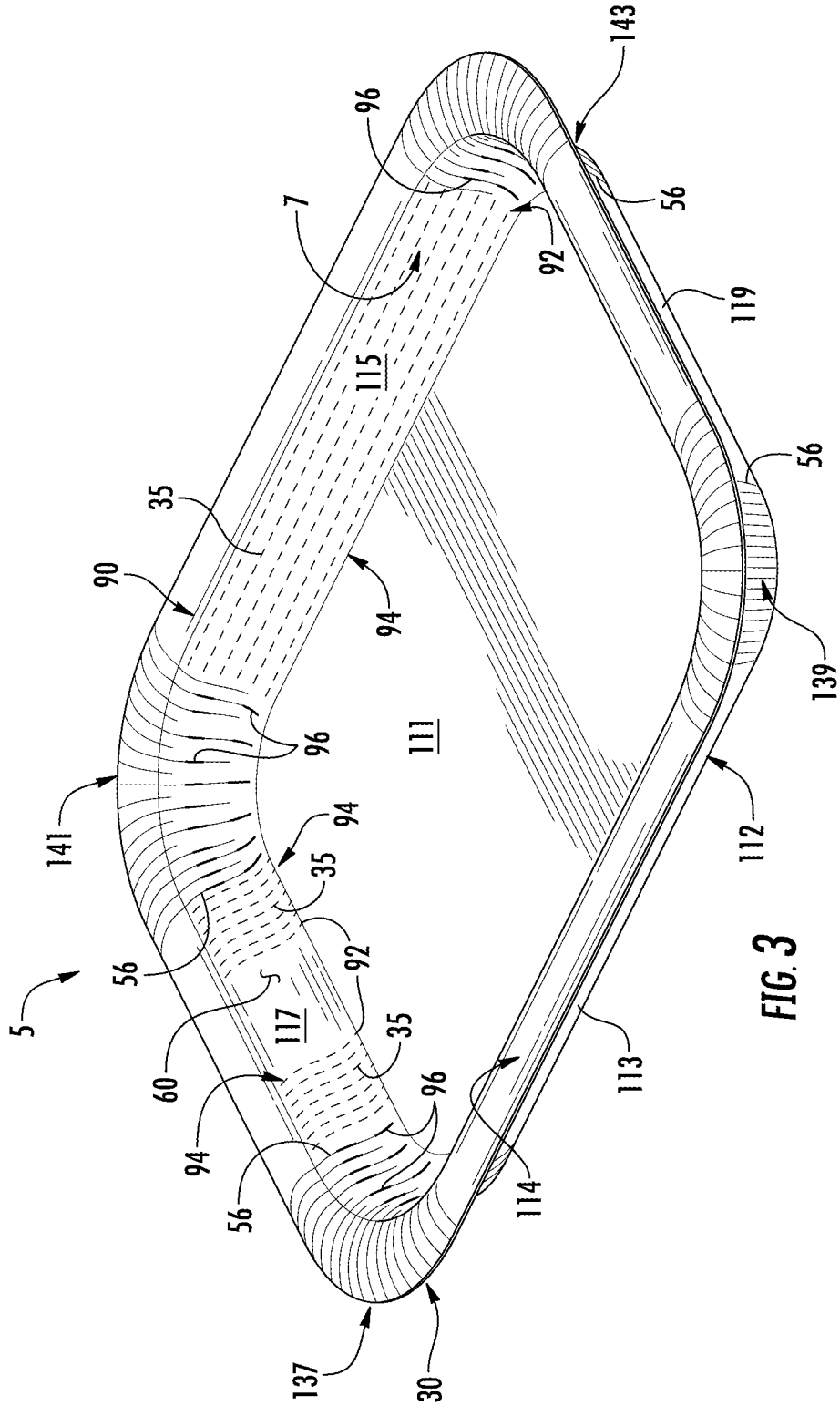

FIG. 3



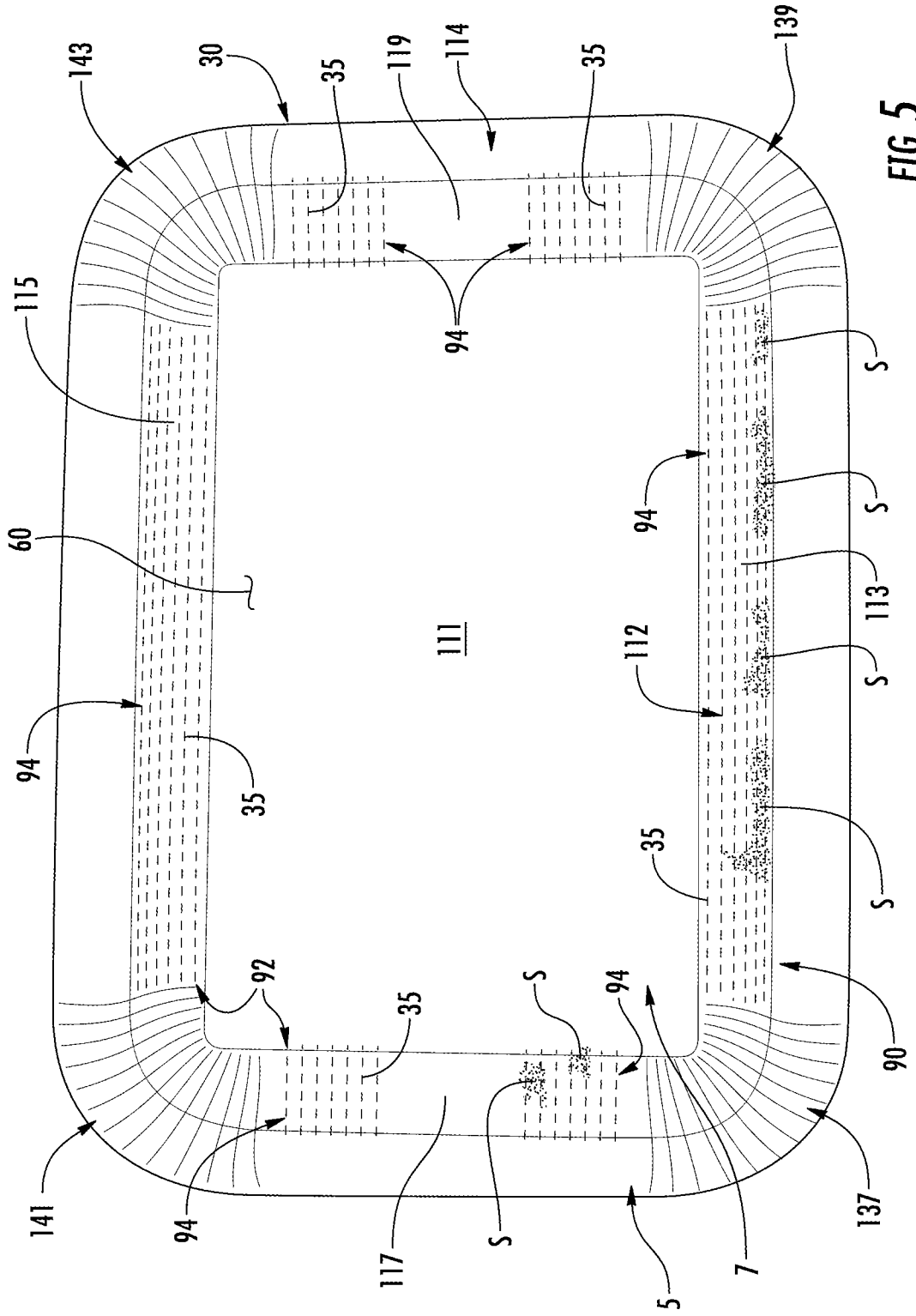

FIG. 5

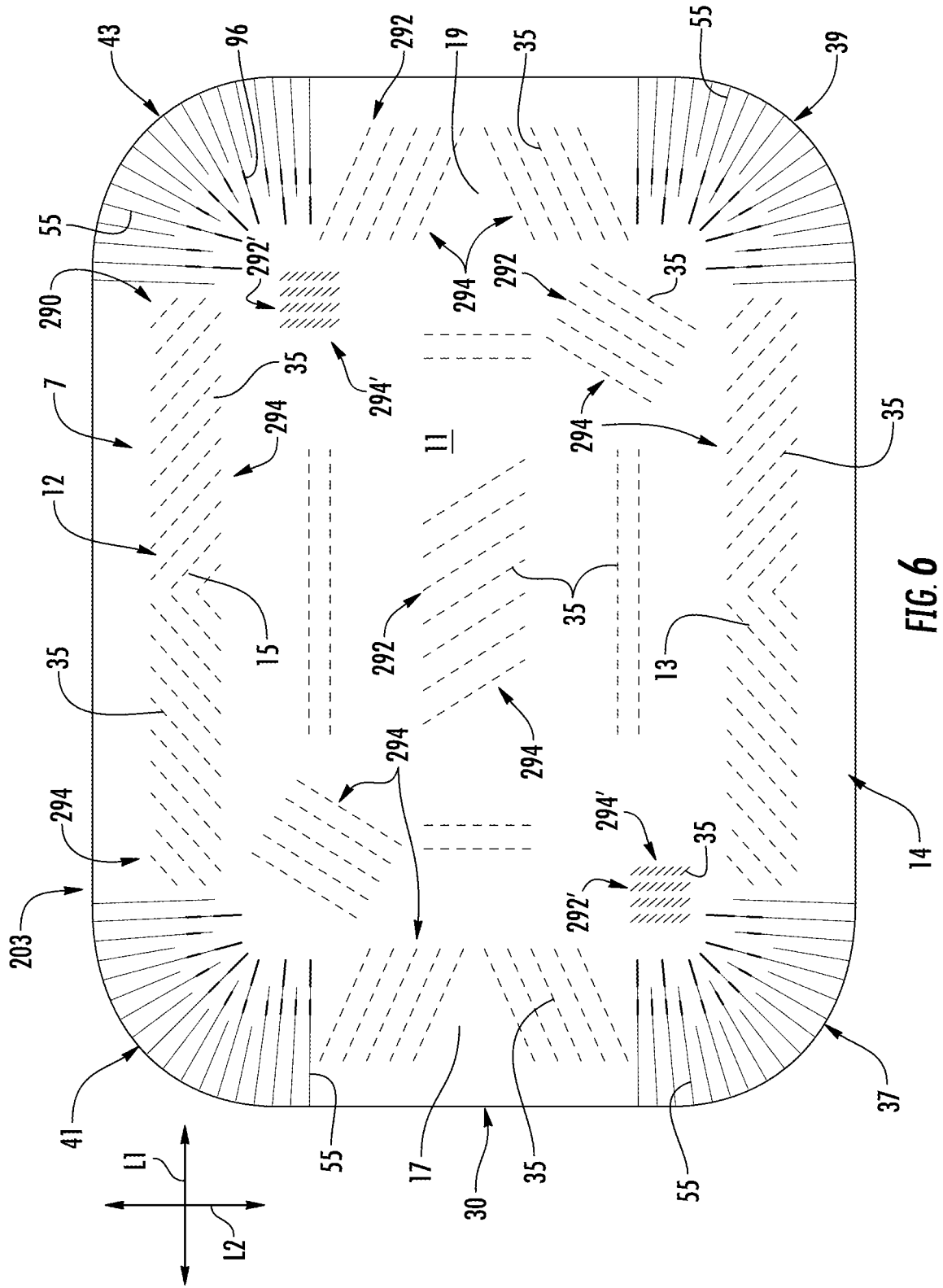

FIG. 6



## INTERNATIONAL SEARCH REPORT

International application No.  
**PCT/US2016/065806****A. CLASSIFICATION OF SUBJECT MATTER****B65D 1/34(2006.01)i, B65D 65/42(2006.01)i**

According to International Patent Classification (IPC) or to both national classification and IPC

**B. FIELDS SEARCHED**Minimum documentation searched (classification system followed by classification symbols)  
B65D 1/34; A23B 4/00; B65B 7/28; B65D 3/22; B65D 81/26; B65B 31/02; B65D 65/42Documentation searched other than minimum documentation to the extent that such documents are included in the fields searched  
Korean utility models and applications for utility models  
Japanese utility models and applications for utility modelsElectronic data base consulted during the international search (name of data base and, where practicable, search terms used)  
eKOMPASS(KIPO internal) & keywords: container, sidewall, flange, base layer, barrier layer, and absorption feature**C. DOCUMENTS CONSIDERED TO BE RELEVANT**

Category*	Citation of document, with indication, where appropriate, of the relevant passages	Relevant to claim No.
Y	US 2014-0103038 A1 (GRAPHIC PACKAGING INTERNATIONAL, INC.) 17 April 2014 See paragraphs [0022] - [0031], [0037], [0039], [0053], claims 1, 18, 32, and figures 1 - 4.	1-56
Y	US 6216855 B1 (GRONE, HORST-DITMAR) 17 April 2001 See column 3, line 64 - column 5, line 16, claims 1, 5, and figures 5 - 8.	1-56
A	US 2004-0163973 A1 (LONGO, EUGENIO) 26 August 2004 See paragraphs [0103] - [0104], [0118] and figures 2, 5.	1-56
A	US 2003-0203080 A1 (GARAVAGLIA et al) 30 October 2003 See paragraphs [0097] - [0103] and figures 1 - 3.	1-56
A	US 3834606 A (ANDERSSON, SVEN INGEMAR) 10 September 1974 See claim 1 and figures 1 - 2.	1-56

 Further documents are listed in the continuation of Box C. See patent family annex.

\* Special categories of cited documents:

"A" document defining the general state of the art which is not considered to be of particular relevance

"E" earlier application or patent but published on or after the international filing date

"L" document which may throw doubts on priority claim(s) or which is cited to establish the publication date of another citation or other special reason (as specified)

"O" document referring to an oral disclosure, use, exhibition or other means

"P" document published prior to the international filing date but later than the priority date claimed

"T" later document published after the international filing date or priority date and not in conflict with the application but cited to understand the principle or theory underlying the invention

"X" document of particular relevance; the claimed invention cannot be considered novel or cannot be considered to involve an inventive step when the document is taken alone

"Y" document of particular relevance; the claimed invention cannot be considered to involve an inventive step when the document is combined with one or more other such documents, such combination being obvious to a person skilled in the art

"&amp;" document member of the same patent family

Date of the actual completion of the international search

13 March 2017 (13.03.2017)

Date of mailing of the international search report

**13 March 2017 (13.03.2017)**

Name and mailing address of the ISA/KR

 International Application Division  
 Korean Intellectual Property Office  
 189 Cheongsa-ro, Seo-gu, Daejeon, 35208, Republic of Korea

Facsimile No. +82-42-481-8578

Authorized officer

LEE, Se Gyoung

Telephone No. +82-42-481-8740



## INTERNATIONAL SEARCH REPORT

Information on patent family members

International application No.

**PCT/US2016/065806**

Patent document cited in search report	Publication date	Patent family member(s)	Publication date		
US 2014-0103038 A1	17/04/2014	CA 2884666 A1	24/04/2014		
		CN 104736442 A	24/06/2015		
		CN 104736442 B	24/08/2016		
		EP 2909090 A1	26/08/2015		
		EP 2909090 A4	18/05/2016		
		JP 2015-532248 A	09/11/2015		
		MX 2015004473 A	14/07/2015		
		US 9371150 B2	21/06/2016		
		WO 2014-062779 A1	24/04/2014		
		US 6216855 B1	17/04/2001	BR 9712833 A	18/01/2000
CA 2265811 A1	26/03/1998				
CZ 291880 B6	18/06/2003				
CZ 9900950 A3	13/12/2000				
DE 19638239 A1	26/03/1998				
EP 0932560 A1	04/08/1999				
EP 0932560 B1	25/07/2001				
EP 0932560 B2	19/01/2005				
ES 2159149 T3	16/09/2001				
ES 2159149 T5	16/05/2005				
GR 3036973 T3	31/01/2002				
HU 228184 B1	28/01/2013				
HU 9904053 A2	28/04/2000				
HU 9904053 A3	29/01/2001				
IL 129036 A	10/03/2002				
IL 129036 D0	17/02/2000				
JP 2001-500459 A	16/01/2001				
PL 332384 A1	13/09/1999				
PT 932560 E	30/11/2001				
PT 932560 T	30/11/2001				
TR 9900622 T2	21/06/1999				
WO 98-12126 A1	26/03/1998				
ZA 9708153 A	03/03/1998				
ZA 9708153 B	03/03/1998				
US 2004-0163973 A1	26/08/2004	AT 359974 T	15/05/2007		
		AU 2002-331335 B2	28/06/2007		
		CA 2452584 A1	23/01/2003		
		CA 2452584 C	06/03/2007		
		DE 60219629 T2	03/01/2008		
		EP 1404589 A1	07/04/2004		
		EP 1404589 B1	18/04/2007		
		NZ 530437 A	27/10/2006		
		US 6983575 B2	10/01/2006		
		WO 03-006337 A1	23/01/2003		
		US 2003-0203080 A1	30/10/2003	AU 2003-203457 A1	26/02/2004
				AU 2003-203457 B2	17/09/2009
EP 1348640 A2	01/10/2003				

**INTERNATIONAL SEARCH REPORT**

Information on patent family members

International application No.

**PCT/US2016/065806**

Patent document cited in search report	Publication date	Patent family member(s)	Publication date
		EP 1348640 A3	11/08/2004
		IT MI20020678 A1	29/09/2003
		IT MI20020678 D0	29/03/2002
US 3834606 A	10/09/1974	US 3932575 A	13/01/1976