

T. ROYER & G. L. ROUSE.  
Hubs for Vehicles.

No. 136,459.

Patented March 4, 1873.

Fig. 1

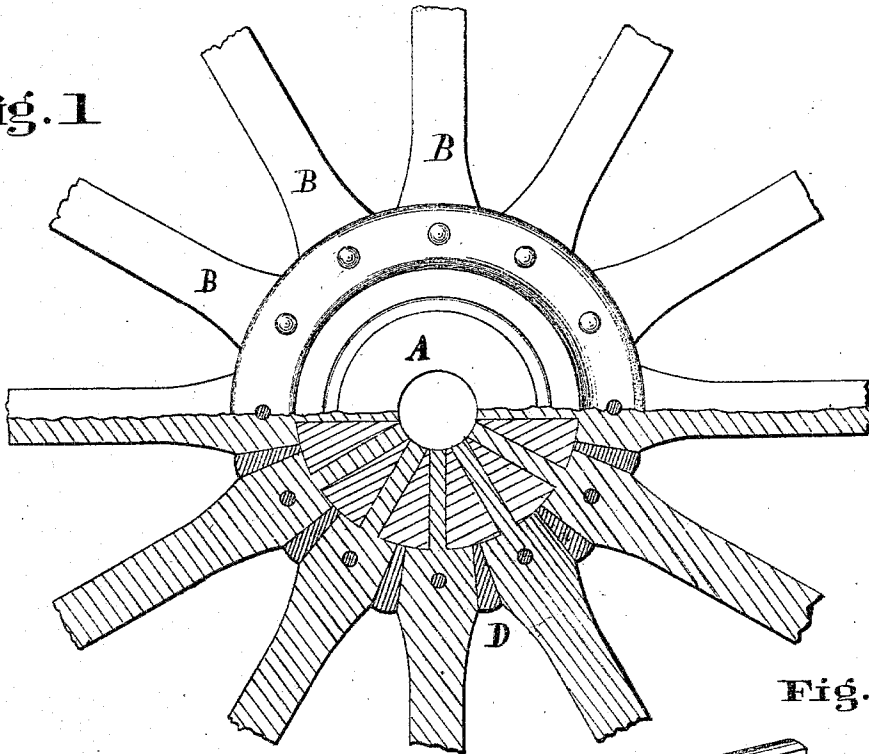

Fig. 3

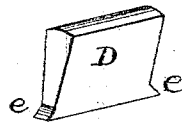
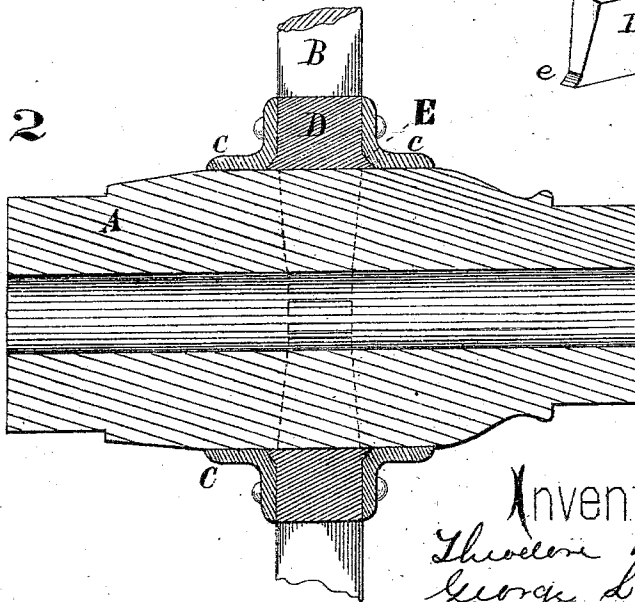

Fig. 2



Attest

C. G. H. Hale  
Jennings & Luskig

Inventor  
Theodore Royer and  
George L. Rouse  
By Fisher & Duncanson  
Attys in fact.

T. ROYER & G. L. ROUSE.  
Hubs for Vehicles.

No. 136,459.

Patented March 4, 1873.

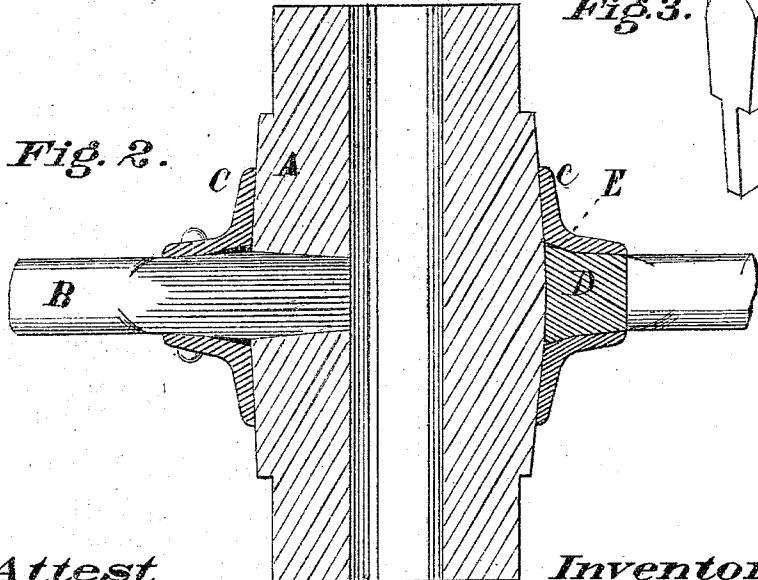
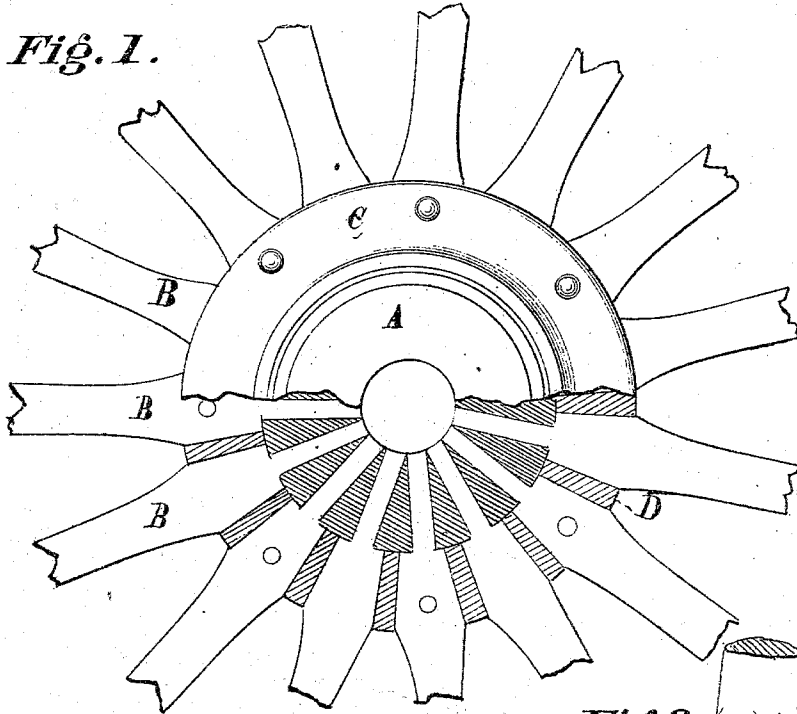

*Fig. 3.*



*Attest*

*Inventor*

*C. G. H. Hale  
Jemiah S. Lushig.*

*Theodore Royer and  
George L. Rouse -  
By Fisher & Duncan  
Attys in fact*

# UNITED STATES PATENT OFFICE.

THEODORE ROYER AND GEORGE L. ROUSE, OF CINCINNATI, OHIO.

## IMPROVEMENT IN HUBS FOR VEHICLES.

Specification forming part of Letters Patent No. 136,459, dated March 4, 1873.

*To all whom it may concern:*

Be it known that we, THEODORE ROYER and GEORGE L. ROUSE, of Cincinnati, county of Hamilton and State of Ohio, have invented an Improvement in Wagon or Carriage Wheels, of which the following is a specification:

This invention relates to an improved mode of constructing wood and metal wheel-hubs; and consists in placing between the spokes of wheels, supported by metallic flanges, wedges of iron, wood, or other suitable material, to support the spokes laterally, and which are themselves held in position by the flanges overlapping lips formed upon each end of the wedge at its lower edge.

In the drawing, Sheet I, Figure I is a view of a wheel-hub with the spokes attached and the wedges and one flange in position. Fig. II is a sectional view, showing more particularly the manner of securing the wedges. Fig. III is a view of one of the wedges, showing its peculiar formation. Sheet II shows similar views when the wedges are made of wood, in which case their form and the form of the flange are somewhat changed.

A represents a wheel-hub mortised in the usual manner. B B, &c., are spokes tenoned to fit the mortises of the hub, and forming, or nearly forming, an arch about the hub. C C are metallic flanges surrounding the hub and having rivet-holes corresponding to the center of each alternate spoke. The flanges, instead of being made with a sharp right angle, are beveled slightly at the angle E so as to overlap the lips of the wedges. D D, &c., are wedges of iron, wood, or other suitable material, designed to give the spokes lateral support. These wedges are made thicker at the back, slightly concave at the edge, and have a projecting lip, *ee*, Fig. III, on each end at the edge. When wooden wedges are used the bevel on the sides of the flanges ought to begin at about the middle of the side of the flange and gradually increase in width toward the bottom of the side, and then end without any sharp turn, as in the case where metallic wedges are used, the object of this alteration in the shape of the bevel being to better hold the wooden wedges in position. The wooden wedges may, however, be secured in any other desired manner.

The shape of the edges of the wooden wedges will correspond with the beveled edges, Fig. II, Plate II. They are held in position by the flanges projecting over these lips.

When the wheel is to be put together the spokes are first driven into the mortises of the hub. The wedges are then forced down closely to the hub between the spokes. When wooden wedges are employed they are to be first dipped in glue before being driven down. The flanges are then put on and drawn firmly together by rivets through each alternate spoke and the corresponding holes in the flanges. As the flanges are drawn together by the rivets the beveled edges, drawing up over the lips of the wedges, force the wedges down more closely between the spokes and secure them firmly, thus uniting together spokes, flanges, and wedges most securely.

As the metallic parts are all applied after the spokes are driven there is no breaking of the fiber of the wood, and thus a great advantage is secured. As the wedges are separate from the flanges they can be made of better material and at less expense.

We are aware that of late wheels have been made with metallic draw-bars connecting the flanges by means of rivet-pins at each end, each of which, in setting up the wheel, must be secured by a slow and laborious process. In this wheel, where the wedges are held in position by the flanges, the labor of riveting is greatly reduced, and thereby the wheel can be made at much less expense.

What we claim is—

1. The combination of metallic flanges slightly beveled at the angle E with wedges formed with a projecting lip at each end of the lower edge, substantially as and for the purposes specified.

2. The combination of metallic flanges beveled on the side next the spoke and toward the hub with wooden wedges whose edges are beveled as described, substantially as and for the purposes set forth.

THEODORE ROYER.  
GEORGE L. ROUSE.

Witnesses:

ALBERT G. CLARK,  
JOHN E. HATCH.