

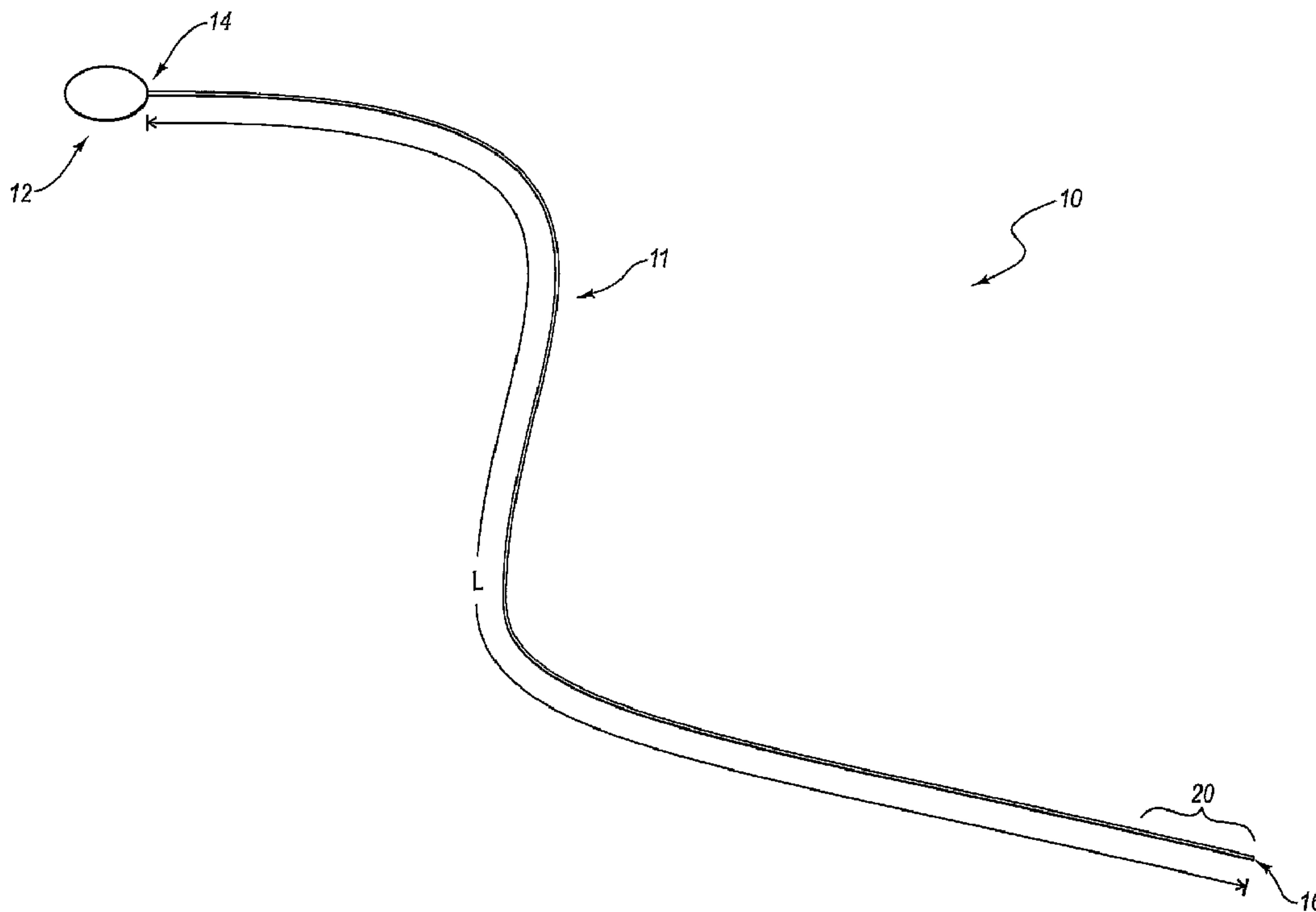

(86) **Date de dépôt PCT/PCT Filing Date:** 2006/08/24
 (87) **Date publication PCT/PCT Publication Date:** 2007/03/01
 (45) **Date de délivrance/Issue Date:** 2014/01/28
 (85) **Entrée phase nationale/National Entry:** 2008/02/19
 (86) **N° demande PCT/PCT Application No.:** US 2006/033079
 (87) **N° publication PCT/PCT Publication No.:** 2007/025046
 (30) **Priorités/Priorities:** 2005/08/24 (US60/710,760);
 2006/04/19 (US60/745,109)

(51) **Cl.Int./Int.Cl. A61M 25/01** (2006.01)
 (72) **Inventeurs/Inventors:**
 BOWN, MATTHEW W., US;
 CHRISTENSEN, MARK A., US;
 ROME, GUY, US;
 HAMATAKE, BRET, US
 (73) **Propriétaire/Owner:**
 C.R. BARD, INC., US
 (74) **Agent:** SMART & BIGGAR

(54) **Titre : STYLET ET SES PROCEDES DE FABRICATION**
 (54) **Title: STYLET APPARATUSES AND METHODS OF MANUFACTURE**



(57) **Abrégé/Abstract:**

A stylet capable of being at least partially disposed within a lumen of a device is disclosed. This stylet may include an elongated body comprising a proximal end, a distal end, and at least one magnetic material. In certain embodiments, the elongated body may



(57) Abrégé(suite)/Abstract(continued):

also include at least one core element, a tubular member circumferentially disposed about at least a portion of the core element, and/or at least one support member circumferentially disposed about at least a portion of the core element. In addition, a matrix material may be disposed between the core element and the tubular member to retain the magnetic material within the elongated body. A catheter assembly including a stylet and a corresponding method of manufacture are also disclosed.

(12) INTERNATIONAL APPLICATION PUBLISHED UNDER THE PATENT COOPERATION TREATY (PCT)

(19) World Intellectual Property Organization
International Bureau



(43) International Publication Date
1 March 2007 (01.03.2007)

PCT

(10) International Publication Number
WO 2007/025046 A1

(51) International Patent Classification:
A61M 25/01 (2006.01)

(74) Agents: LEE, Jonathan, R. et al.; HOLLAND & HART, LLP, 60 East South Temple, Suite 2000, Salt Lake City, UT 84111 (US).

(21) International Application Number:
PCT/US2006/033079

(81) Designated States (*unless otherwise indicated, for every kind of national protection available*): AE, AG, AL, AM, AT, AU, AZ, BA, BB, BG, BR, BW, BY, BZ, CA, CH, CN, CO, CR, CU, CZ, DE, DK, DM, DZ, EC, EE, EG, ES, FI, GB, GD, GE, GH, GM, HN, HR, HU, ID, IL, IN, IS, JP, KE, KG, KM, KN, KP, KR, KZ, LA, LC, LK, LR, LS, LT, LU, LV, LY, MA, MD, MG, MK, MN, MW, MX, MY, MZ, NA, NG, NI, NO, NZ, OM, PG, PH, PL, PT, RO, RS, RU, SC, SD, SE, SG, SK, SL, SM, SV, SY, TJ, TM, TN, TR, TT, TZ, UA, UG, US, UZ, VC, VN, ZA, ZM, ZW.

(22) International Filing Date: 24 August 2006 (24.08.2006)

(25) Filing Language: English

(26) Publication Language: English

(30) Priority Data:
60/710,760 24 August 2005 (24.08.2005) US
60/745,109 19 April 2006 (19.04.2006) US

(84) Designated States (*unless otherwise indicated, for every kind of regional protection available*): ARIPO (BW, GH, GM, KE, LS, MW, MZ, NA, SD, SL, SZ, TZ, UG, ZM, ZW), Eurasian (AM, AZ, BY, KG, KZ, MD, RU, TJ, TM), European (AT, BE, BG, CH, CY, CZ, DE, DK, EE, ES, FI, FR, GB, GR, HU, IE, IS, IT, LT, LU, LV, MC, NL, PL, PT, RO, SE, SI, SK, TR), OAPI (BF, BJ, CF, CG, CI, CM, GA, GN, GQ, GW, ML, MR, NE, SN, TD, TG).

(71) Applicant (*for all designated States except US*): C. R. BARD, INC. [US/US]; 730 Central Avenue, Murray Hill, NJ 07974 (US).

(72) Inventors: BOWN, Matthew; 1536 West 1200 South, Woods Cross, UT 84087 (US). CHRISTENSEN, Mark; 1230 East First South, Salt Lake City, UT 84102 (US). ROME, Guy; 6135 Dunford Court, West Valley City, UT 84128 (US). HAMATAKE, Brett; 297 West Clark Street, Grantsville, UT 84029 (US).

Published:
— with international search report

[Continued on next page]

(54) Title: STYLET APPARATUSES AND METHODS OF MANUFACTURE

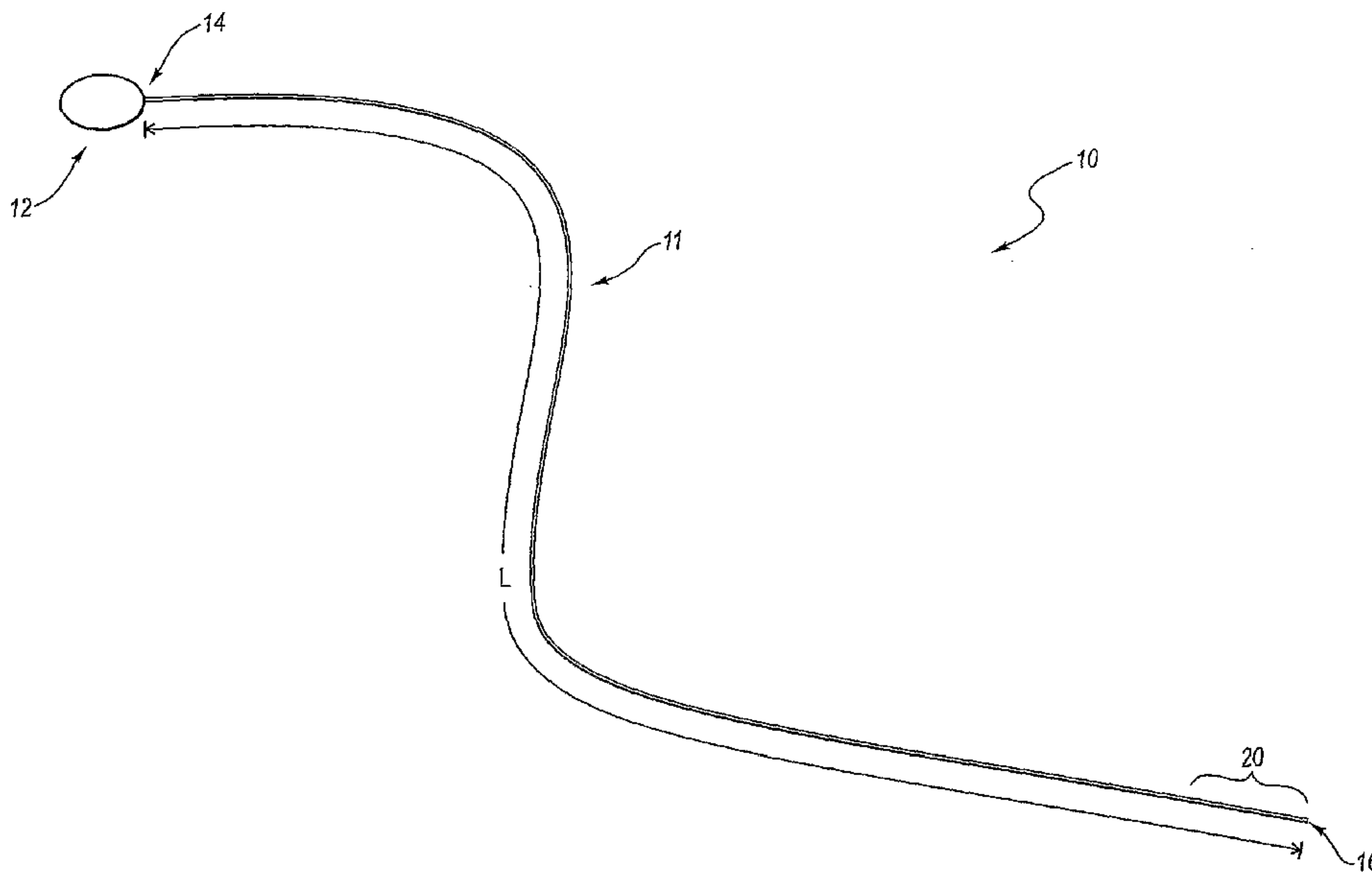

(57) Abstract: A stylet capable of being at least partially disposed within a lumen of a device is disclosed. This stylet may include an elongated body comprising a proximal end, a distal end, and at least one magnetic material. In certain embodiments, the elongated body may also include at least one core element, a tubular member circumferentially disposed about at least a portion of the core element, and/or at least one support member circumferentially disposed about at least a portion of the core element. In addition, a matrix material may be disposed between the core element and the tubular member to retain the magnetic material within the elongated body. A catheter assembly including a stylet and a corresponding method of manufacture are also disclosed.

WO 2007/025046 A1

WO 2007/025046 A1



— *before the expiration of the time limit for amending the claims and to be republished in the event of receipt of amendments*

For two-letter codes and other abbreviations, refer to the "Guidance Notes on Codes and Abbreviations" appearing at the beginning of each regular issue of the PCT Gazette.

STYLET APPARATUSES AND METHODS OF MANUFACTURE

BACKGROUND

[0001] One function of a stylet is to facilitate the navigation of a catheter, cannula, hollow needle, or the like within a select portion of a patient, such as within a patient's vasculature, by providing (*i.e.*, imparting) rigidity or stiffness to the catheter. For example, a stylet may comprise a slender, solid, and/or hollow metal member that, when positioned within a lumen of a catheter, stiffens the catheter sufficiently to allow for placement of the catheter within the patient.

BRIEF SUMMARY

[0002] In at least one embodiment, a stylet capable of being at least partially disposed within a lumen of a device may comprise an elongated body comprising a proximal end, a distal end, and at least one magnetic material. The elongated body may also further comprise at least one core element, a tubular member circumferentially disposed about at least a portion of the core element, and/or a support member circumferentially disposed about at least a portion of the core element. A matrix material may also be disposed between the core element and the tubular member to retain the magnetic material within the elongated body.

[0003] In certain embodiments, the core element may comprise a first region, a second region having a diameter that is less than a diameter of the first region, and a transition region coupling the second region to the first region. The magnetic material may be circumferentially disposed about at least a portion of the second region of the core element, disposed within the tubular member, positioned proximate the distal end of the elongated body of the stylet, or otherwise positioned within the elongated body of the stylet. For example, in certain embodiments, at least one of the core element, the tubular member, and the support member may comprise a magnetic region and a non-magnetic region. In addition, the magnetic material may comprise at least one permanent magnet coupled to the elongated body of the stylet.

[0004] According to certain embodiments, the tubular member may be circumferentially disposed about at least a portion of the support member. In an additional embodiment, the support member may be circumferentially disposed about at least a portion of the tubular member. In addition, the tubular member may comprise a reinforcing element and/or a groove defined within the tubular member. The elongated

76186-212

body may also comprise at least one core element and a coating circumferentially disposed about at least a portion of the core element and at least a portion of the magnetic material.

[0005] In certain embodiments, a method of manufacturing a stylet may comprise forming an elongated body comprising a proximal end, a distal end, and at least one magnetic material. In at least one embodiment, the step of forming the elongated body may comprise magnetizing at least a portion of the elongated body. The step of forming the elongated body may also further comprise disposing a support member about at least a portion of the core element and/or disposing a matrix material between the core element and the tubular member to retain the magnetic material within the elongated body. In addition, the step of forming the elongated body may comprise providing at least one core element, disposing a tubular member about at least a portion of the core element, and disposing the magnetic material within the tubular member.

[0006] In at least one embodiment, a catheter assembly may comprise a catheter defining a lumen and at least one stylet at least partially disposed within the lumen of the catheter. In certain embodiments, the at least one stylet may comprise an elongated body comprising a proximal end, a distal end, and at least one magnetic material.

[0006a] According to one aspect of the present invention, there is provided a stylet, comprising: an elongated core element completely surrounded by a polymer member from a proximal end to a distal end thereof, the polymer member extending distal of the core element distal end; a closure element affixed to a distal end of the polymer member; and a plurality of magnetic elements disposed distal of the core element distal end and proximal of the closure element, the polymer member surrounding the magnetic elements.

[0006b] According to another aspect of the present invention, there is provided a stylet, comprising: an elongated core element surrounded by a polymer member from a proximal end of the core element to a distal end thereof, the polymer member extending distal of the core element distal end, the polymer member affixed to at least a portion of the core element; a closure element affixed to a distal end of the polymer member; and a plurality of permanent

76186-212

magnetic elements disposed distal of the core element distal end and proximal of the closure element, the polymer member surrounding the magnetic elements.

[0006c] According to yet another aspect of the present invention, there is provided a catheter assembly, comprising: a catheter defining a lumen; and the stylet described herein, at
5 least partially disposed in the catheter lumen.

[0007] Features from any of the above mentioned embodiments may be used in combination with one another in accordance with the instant disclosure. In addition, other features and advantages of the instant disclosure will become apparent to those of ordinary skill in the art through consideration of the ensuing description, the accompanying drawings,
10 and the appended claims.

BRIEF DESCRIPTION OF THE DRAWINGS

[0008] The accompanying drawings illustrate a number of exemplary embodiments and are a part of the specification. Together with the following description, these drawings demonstrate and explain various principles of the instant disclosure.

15 [0009] FIG. 1 is a schematic view of an exemplary stylet according to at least one embodiment;

[0010] FIG. 2 is a partial cross-sectional side view of an exemplary stylet comprising a plurality of magnetic elements according to at least one embodiment;

[0011] FIG. 3 is a partial cross-sectional side view of an exemplary stylet according to an additional embodiment;

[0012] FIG. 4 is a partial cross-sectional side view of an exemplary stylet according to an additional embodiment;

[0013] FIG. 5 is a partial cross-sectional side view of an exemplary stylet according to an additional embodiment;

[0014] FIG. 6 is a partial cross-sectional side view of an exemplary stylet according to an additional embodiment;

[0015] FIG. 7 is a partial cross-sectional side view of an exemplary stylet according to an additional embodiment;

[0016] FIG. 8 is a partial cross-sectional side view of an exemplary stylet according to an additional embodiment;

[0017] FIG. 9 is a partial cross-sectional side view of an exemplary stylet according to an additional embodiment;

[0018] FIG. 10 is a partial cross-sectional side view of an exemplary stylet according to an additional embodiment;

[0019] FIG. 11 is a partial cross-sectional side view of an exemplary stylet according to an additional embodiment;

[0020] FIG. 12 is a partial cross-sectional side view of an exemplary stylet according to an additional embodiment;

[0021] FIG. 13 is a partial cross-sectional side view of an exemplary stylet according to an additional embodiment;

[0022] FIG. 14 is a partial cross-sectional side view of an exemplary stylet according to an additional embodiment;

[0023] FIG. 15 is a partial cross-sectional side view of an exemplary stylet according to an additional embodiment;

[0024] FIG. 16 is a partial cross-sectional side view of an exemplary stylet according to an additional embodiment;

[0025] FIG. 17 is a partial cross-sectional side view of an exemplary stylet according to an additional embodiment;

[0026] FIG. 18 is a partial cross-sectional side view of an exemplary stylet according to an additional embodiment;

[0027] FIG. 19 is a partial cross-sectional side view of an exemplary stylet according to an additional embodiment;

[0028] FIG. 20 is a partial cross-sectional side view of an exemplary stylet according to an additional embodiment;

[0029] FIG. 21 is a partial cross-sectional side view of an exemplary stylet according to an additional embodiment;

[0030] FIG. 22 is a partial cross-sectional side view of an exemplary stylet according to an additional embodiment;

[0031] FIG. 23 is a partial cross-sectional side view of an exemplary stylet according to an additional embodiment;

[0032] FIG. 24 is a partial cross-sectional side view of an exemplary stylet according to an additional embodiment;

[0033] FIG. 25 is a partial cross-sectional side view of an exemplary stylet according to an additional embodiment;

[0034] FIG. 26 is a partial cross-sectional side view of an exemplary stylet according to an additional embodiment;

[0035] FIG. 27 is a partial cross-sectional side view of an exemplary stylet according to an additional embodiment;

[0036] FIG. 28 is a partial cross-sectional side view of an exemplary stylet according to an additional embodiment;

[0037] FIG. 29 is a partial cross-sectional side view of an exemplary stylet according to an additional embodiment;

[0038] FIG. 30 is a partial cross-sectional side view of an exemplary stylet according to an additional embodiment;

[0039] FIG. 31 is a partial cross-sectional end view of an exemplary stylet according to an additional embodiment;

[0040] FIG. 32 is a partial cross-sectional end view of an exemplary stylet according to an additional embodiment;

[0041] FIG. 33 is a partial cross-sectional end view of an exemplary stylet according to an additional embodiment;

[0042] FIG. 34 is a partial cross-sectional end view of an exemplary stylet according to an additional embodiment;

[0043] FIG. 34 is a partial cross-sectional end view of an exemplary stylet according to an additional embodiment;

[0044] FIG. 35 is a partial cross-sectional end view of an exemplary catheter assembly according to at least one embodiment; and

[0045] FIG. 36 is a perspective view of an exemplary catheter assembly according to at least one embodiment.

[0046] Throughout the drawings, identical reference characters and descriptions indicate similar, but not necessarily identical, elements. While the exemplary embodiments described herein are susceptible to various modifications and alternative forms, specific embodiments have been shown by way of example in the drawings and will be described in detail herein. However, one of skill in the art will understand that the exemplary embodiments described herein are not intended to be limited to the particular forms disclosed. Rather, the instant disclosure covers all modifications, equivalents, and alternatives falling within the scope of the appended claims.

DETAILED DESCRIPTION

[0047] FIG. 1 is a schematic view of an exemplary stylet 10 according to at least one embodiment. For purposes of this disclosure, the term “stylet” shall be broadly construed to include any form or type of structure capable of being at least partially positioned or disposed within a lumen of a catheter, cannula, hollow needle, or other suitable device to provide (i.e., impart) increased stiffness or rigidity to the device. As seen in FIG. 1, in at least one embodiment, stylet 10 may comprise an elongated body 11 extending between a proximal end 14 and a distal end 16. Elongated body 11 may be formed in any number of shapes and sizes. For example, in certain embodiments, elongated body 11 may have a substantially constant cross-sectional size, taken transverse to the longitudinal axis of elongated body 11. Elongated body 11 may also have a length L extending from proximal end 14 to distal end 16, as shown in FIG. 1. In certain embodiments, a tab element 12 may also be provided at the proximate end 14 of elongated body 11 to provide a convenient and easily graspable structure for a user to grasp when manipulating stylet 10.

[0048] Elongated body 11 of stylet 10 may comprise any number or combination of materials. For example, in at least one embodiment, and as discussed in

greater detail below, at least a portion of elongated body 11 may comprise at least one magnetic material. In general, this magnetic material may comprise any type or form of magnetic material, including both permanent magnetic materials and electromagnetic materials. For example, in one embodiment, elongated body 11 of stylet 10 may comprise a rare-earth magnet (*e.g.*, samarium cobalt and/or neodymium iron boron). In another embodiment, elongated body 11 of stylet 10 may comprise an AlNiCo magnetic material, a plastic magnetic material (*e.g.*, PANiCNQ), or a ceramic magnetic material, such as barium ferrite ($\text{BaO}_6\text{Fe}_2\text{O}_3$) or strontium ferrite ($\text{SrO}_6\text{Fe}_2\text{O}_3$) and iron oxide (Fe_3O_4). Elongated body 11 of stylet 10 may also comprise, in certain embodiments, an electromagnetic material, such as a solenoid, that generates a magnetic field upon application of an electric current.

[0049] As discussed in greater detail below, elongated body 11 of stylet 10 may comprise both solid (including both pliant and rigid solids) or non-solid magnetic materials. For example, elongated body 11 of stylet 10 may comprise a magnetic material having a plurality of magnetic particles dispersed within a pliable material, such as a putty, polymer, silicone, highly viscous liquid, or any other suitable material. In additional embodiments, elongated body 11 of stylet 10 may comprise a magnetic material having a plurality of magnetic particles contained within a matrix, suspension, or slurry. This exemplary magnetic suspension or slurry may comprise any liquid (*e.g.*, oil, water, glycerin, alcohol, polymers, or the like) in combination with any type of magnetic material, such as particulate magnetic materials.

[0050] In at least one embodiment, exemplary stylet 10 may comprise a magnetic material that exhibits an observable dipole (*e.g.*, an individual magnetic dipole or a collective magnetic dipole exhibited by a plurality of magnets), which may provide an indication of the position and/or orientation of the magnetic material and, therefore, the position and/or orientation of at least a portion of exemplary stylet 10. For example, stylet 10 may comprise a magnetic material having a magnetic dipole that, when stylet 10 is inserted into a patient, may be detected from outside of the patient's body using detection technology (discussed in greater detail below) to indicate the position and/or orientation of stylet 10 within the patient's body. In many embodiments, the magnetic material of stylet 10 may exhibit a relatively high field strength for a given volume so that the orientation of its magnetic dipole may be easily detected.

[0051] Generally speaking, the poles of the magnetic material of stylet 10 may be positioned or oriented in any number of ways. For example, the dipole of the magnetic material of exemplary stylet 10 may either be oriented substantially parallel to the longitudinal axis of stylet 10 (*i.e.*, the axis extending from proximal end 14 to distal end 16 of stylet 10) or substantially perpendicular to the longitudinal axis of stylet 10. In addition, the north pole of the magnetic material of stylet 10 may be positioned proximate to the distal end 16 of stylet 10, with the south pole of the magnetic material facing the proximate end 14 of stylet 10.

[0052] In general, any type or form of detection system may be used to detect the dipole of the magnetic material of stylet 10 to provide an indication of the position and/or orientation of the magnetic material and, therefore, the position and/or orientation of at least a portion of exemplary stylet 10 positioned within a patient's body. Examples of suitable detection apparatuses include, without limitation, the various detection apparatuses disclosed in U.S. Pat. Nos. 5,879,297; 6,129,668; 6,216,028; and 6,263,230 to Haynor et al. ("the Haynor Patents"), the entirety of each of which is incorporated, in its entirety, by this reference. For example, an exemplary detection apparatus may comprise a plurality of magnetic sensors oriented in a known direction to generate a set of signals based on the strength and direction of the magnetic field generated by the magnetic material (or plurality of magnetic materials) of stylet 10. A processor may then calculate an estimated position of the magnetic material of stylet 10 in a three-dimensional space based on the predicted and actual magnetic field strength of the magnetic material derived from the set of signals generated by the magnetic sensors. For example, the location and/or orientation of the magnetic material of stylet 10 may be calculated by comparing the difference between the predicted magnetic field strength and the actual measured magnetic field strength of the magnetic material. In certain embodiments, a display connected to the processor may display the position of the magnetic material of the stylet 10 in a three-dimensional space. Accordingly, a detection apparatus, such as the exemplary detection apparatus described herein, may detect the magnetic field generated by the magnetic material of stylet 10 positioned within a patient's body in order to determine the position and/or orientation of at least a portion of stylet 10.

[0053] FIG. 2 is a partial cross-sectional side view of an exemplary stylet 10 according to at least one embodiment. As seen in this figure, exemplary stylet 10 may comprise a tubular member 54 circumferentially disposed about at least a portion of an elongated core element 60. Core element 60 may be formed in any number of shapes and sizes and of any number or combination of suitable materials; including, for example, conventional stylet materials such as stainless steel. Similarly, tubular member 54, which generally represents any structure capable of at least partially surrounding at least a portion of core element 60, may be formed of any number or combination of materials; including, for example, polymers (such as polyimide, silicone, or so-called heat shrink tubing), metal, or other suitable materials. Tubular member 54 may be positioned so as to surround all or merely a portion of the length of core element 60. For example, in the exemplary embodiment illustrated in FIG. 2, tubular member 54 may be coupled to, and at least partially surround, a distal region 56 of core element 60. In additional embodiments, described and illustrated below, tubular member 54 may extend along the entire length of core element 60; *i.e.*, from distal end 16 to proximate end 14. Tubular member 54 may also be coupled or affixed to at least a portion of core element 60 in any number of ways; including, for example, by adhering, melting, or otherwise affixing tubular member 54 to the outer surface of core element 60.

[0054] In at least one embodiment, exemplary stylet 10 may comprise one or more magnetic elements 70. As detailed above, magnetic elements 70 may comprise any type or form of magnetic material, such as, for example, a rare-earth magnet or a ceramic magnetic material. In general, magnetic elements 70 may be positioned within either a select region of, or throughout the entirety of, elongated body 11. For example, in the exemplary embodiment illustrated in FIG. 2, magnetic elements 70 may be positioned within a distal region 20 of stylet 10. In certain embodiments, magnetic elements 70 may be housed within tubular member 54. In general, magnetic elements 70 may be retained within tubular member 54 in any number of ways; including, for example, by a closure element 62 provided at the distal end 16 of stylet 10. In additional embodiments, magnetic elements 70 may be coupled to tubular member 54 by an adhesive, polymer, gel, epoxy, or other suitable material.

[0055] In at least one embodiment, one or more gaps 52 may be provided between longitudinally adjacent magnetic elements 70. In certain embodiments, gaps 52

may increase the flexibility of distal region 20 of stylet 10 and may allow tubular member 54 to be bent without bringing longitudinally adjacent magnetic elements 70 into contact with one another. The size and configuration of gaps 52 may also be modified as needed to impart a desired level of stiffness or flexibility to distal region 20 of stylet 10. In addition, gaps 52 may be filled with a pliant filling material, such as, for example, silicone, rubber, or any other suitable material. In certain embodiments, gaps 52 may enable exemplary stylet 10, in combination with a catheter, to traverse an arcuate subcutaneous path within a patient.

[0056] As detailed above, tubular member 54 may be formed of any number or combination of materials. For example, in at least one embodiment, tubular member 54 may comprise a metal or metallic material that exhibits a desired level of stiffness. In this exemplary embodiment, the stiffness or flexibility of tubular member 54 may be adjusted by modifying the thickness of the outer wall of metallic tubular member 54 and/or by defining a plurality of grooves, holes, notches, or other features within the outer wall of tubular member 54, as discussed in greater detail below.

[0057] FIG. 3 is a partial cross-sectional side view of an exemplary stylet 10 according to an additional embodiment. As seen in this exemplary embodiment, exemplary stylet 10 may comprise a tubular member 54 circumferentially disposed about an elongated core element 60 and a plurality of magnetic elements 70. In contrast to the exemplary embodiment illustrated in FIG. 2, tubular member 54 may extend along, and be circumferentially disposed about, substantially the entire length of core element 60. In other words, tubular member 54 may extend substantially between proximal end 14 and distal end 16 of exemplary stylet 10. In certain embodiments, this configuration may help resist movement of core element 60 relative to tubular member 54.

[0058] FIG. 4 is a partial cross-sectional side view of an exemplary stylet 10 according to an additional embodiment. As seen in this figure, exemplary stylet 10 may comprise an elongated core element 60, a tubular member 54 circumferentially disposed about a distal region 56 of core element 60, and a plurality of magnetic elements 70 housed within tubular member 54 proximate distal region 20. In at least one embodiment, exemplary stylet 10 may also comprise at least one support element 80 circumferentially disposed about at least a portion of core element 60. Support element 80 generally represents any form or type of structure or element capable of providing a

select level of flexibility or rigidity to core element 60 and/or exemplary stylet 10. Examples of support element 80 include support coils, wires, or the like. In certain embodiments, support element 80 may be affixed or bonded to at least a portion of the outer surface of core element 60, which may allow for select tailoring of the amount of rigidity or stiffness provided by support element 80. Optionally, support element 80 may be integrally formed with, or disposed within, at least a portion of core element 60. In certain embodiments, and as illustrated in FIG. 4, the distal end of support element 80 may be positioned proximate or adjacent to the proximal end of tubular member 54.

[0059] FIG. 5 is a partial cross-sectional side view of an exemplary stylet 10 according to an additional embodiment. As seen in this figure, exemplary stylet 10 may comprise an elongated core element 60, a tubular member 54 circumferentially disposed about substantially the entire length of core element 60, and a plurality of magnetic elements 70 housed within tubular member 54 proximate distal region 20. In at least one embodiment, tubular member 54 of exemplary stylet 10 may also comprise a reinforcing element 55. Reinforcing element 55 generally represents any type or form of structure capable of providing a desired level of flexibility or stiffness to tubular member 54 and/or exemplary stylet 10. Examples of reinforcing element 55 include a reinforcing coil or braid, a flexible reinforcing wire, or the like. Reinforcing element 55 may be positioned within, integrally formed with, adhered to, or otherwise attached to tubular member 54 in any number of ways. Reinforcing element 55 may also be oriented relative to exemplary stylet 10 in any number of ways; including, for example, longitudinally along at least a portion of the length of stylet 10 (*i.e.*, longitudinally along an elongation axis of stylet 10) or radially about portions of stylet 10 (*e.g.*, radially, helically, or otherwise wrapped about portions of stylet 10). In addition, reinforcing element 55 may or may not be coupled to tubular member 54. As with tubular member 54, reinforcing member 55 may extend along a portion of core element 60 within a region 56, or may extend along substantially the entire length of core element 60 (*i.e.*, from the proximal end 14 to the distal end 16 of stylet 10). In certain embodiments, the size, length, or stiffness of, and/or the material used to form reinforcement element 55 may be selected based on a desired level of flexibility or rigidity for stylet 10.

[0060] FIG. 6 is a partial cross-sectional side view of an exemplary stylet 10 according to an additional embodiment. As seen in this exemplary embodiment,

exemplary stylet 10 may comprise an elongated core element 60, a tubular member 54 circumferentially disposed about a distal region 56 of core element 60, and a plurality of magnetic elements 70 housed within tubular member 54 proximate distal region 20. As mentioned above, tubular member 54 may also comprise features that influence its flexibility or stiffness. For example, as shown in FIG. 6, one or more grooves 97 may be defined along the outer surface of tubular member 54 to provide a desired level of flexibility to tubular member 54. Grooves 97, which may be formed in any number of shapes and sizes, generally represent any form of groove, indentation, hole, aperture, or notch defined into or through one or more portions of tubular member 54. Examples of grooves 97 include, without limitation, circumferential grooves, longitudinally extending grooves, helical grooves, holes, or other suitable features. Grooves 97 may be defined along or through tubular member 54 by any number of processes known in the art; including, for example, laser machining, electrode discharge machining, etching, grinding, or sawing (*e.g.*, with a diamond-coated wafer dicing saw). Similar to the exemplary embodiment illustrated in FIG. 5, and as shown in FIG. 6, tubular member 54 may be closed at the distal end 16 of stylet 10 by a weld element 30. As with closure element 62, weld element 30 generally represents any form or type of structure used to retain magnetic elements 70 within tubular member 54.

[0061] FIG. 7 is a partial cross-sectional side view of an exemplary stylet 10 according to an additional embodiment. As seen in this figure, exemplary stylet 10 may comprise an elongated core element 60, a support element 80 circumferentially disposed about at least a portion of core element 60, a tubular member 54 comprising a reinforcing element 55 circumferentially disposed about a distal region 56 of core element 60, and a plurality of magnetic elements 70 housed within tubular member 54 proximate distal region 20. As detailed above, the stiffness or rigidity of exemplary stylet 10 may be modified or tailored as desired by adding or removing support element 80, tubular member 54, and/or reinforcing element 55. In the exemplary embodiment illustrated in FIG. 7, each of these elements may be used in combination to impart a greater amount of stiffness or rigidity to stylet 10.

[0062] FIG. 8 is a partial cross-sectional side view of an exemplary stylet 10 according to an additional embodiment. As seen in this figure, exemplary stylet 10 may comprise an elongated core element 60, a tubular member 54 circumferentially disposed

about core element 60, and a plurality of magnetic elements 70 housed within tubular member 54 proximate distal region 20. In addition, as opposed to comprising a weld element 30 or a closure element 62, tubular member 54 may comprise a closed end 58. Because tubular member 54 may comprise a closed end 58, as opposed to comprising a weld element 30 or a closure element 62, additional processes for forming either weld element 30 or closure element 62 may be avoided.

[0063] FIG. 9 is a partial cross-sectional side view of an exemplary stylet 10 according to an additional embodiment. As seen in this exemplary embodiment, exemplary stylet 10 may comprise an elongated core element 60, a support element 80 circumferentially disposed about at least a portion of core element 60, a tubular member 54 circumferentially disposed about core element 60, and a plurality of magnetic elements 70 housed within tubular member 54 proximate distal region 20. As illustrated in FIG. 9, tubular member 54 may be circumferentially disposed about substantially the entire length of both support element 80 and core element 60 (*i.e.*, from the distal end 16 of stylet 10 to proximate end 14). In addition, as with the exemplary embodiment illustrated in FIG. 8, tubular member 54 may comprise a closed end 58. As with previous embodiments, a filling material 71 may also be disposed between magnetic elements 70 within tubular member 54. As detailed above, filling material 71 may comprise any number of suitable pliant materials to maintain or facilitate separation of adjacent magnetic elements 70, thereby providing a desired level of flexibility to distal region 20 of stylet 10. In additional embodiments, in place of filling material 71, spacing elements (such as spacing elements 92, described in connection with FIG. 23 below) may be positioned between longitudinally adjacent magnetic elements 70.

[0064] FIG. 10 is a partial cross-sectional side view of an exemplary stylet 10 according to an additional embodiment. As seen in this exemplary embodiment, exemplary stylet 10 may comprise an elongated core element 60 and a support element 80 circumferentially disposed about substantially the entire length of core element 60. In at least one embodiment, at least a portion of support element 80, core element 60, or both, may comprise a magnetic material. For example, as shown in FIG. 10, support element 80 may comprise a magnetic material within a magnetic region 40, while comprising a non-magnetic material within a non-magnetic region 41. In certain embodiments, support element 80 may be manufactured by first forming support element

80 of a non-magnetized material and then magnetizing a select portion (*e.g.*, magnetic region 40) of support element 80. In another embodiment, support element 80 may be formed to initially include a magnetic material within region 40. Magnetization of magnetic region 40 may be accomplished by utilizing any known material or process for magnetization as known in the art, without limitation.

[0065] FIG. 11 is a partial cross-sectional side view of an exemplary stylet 10 according to an additional embodiment. As seen in this exemplary embodiment, exemplary stylet 10 may comprise an elongated core element 60 and a support element 80 circumferentially disposed about substantially the entire length of core element 60. In at least one embodiment, stylet 10 may also comprise a magnetic coil 81 circumferentially disposed about a select portion of core element 60. For example, as illustrated in FIG. 11, magnetic coil 81 may be circumferentially disposed about a distal region of core element 60 to form a magnetic region 40. In certain embodiments, magnetic coil 81 may be longitudinally disposed between portions (*e.g.*, coils) of support element 80. Optionally, magnetic coil 81 may be circumferentially disposed about (*i.e.*, radially surround) support element 80.

[0066] FIG. 12 is a partial cross-sectional side view of an exemplary stylet 10 according to an additional embodiment. As seen in this exemplary embodiment, exemplary stylet 10 may comprise an elongated core element 60 and a support element 80 circumferentially disposed about substantially the entire length of core element 60. In at least one embodiment, at least a portion of core element 60 may comprise a magnetic material. For example, as shown in FIG. 12, core element 60 may comprise a non-magnetic portion within non-magnetic region 41 of stylet 10 and a magnetic portion within magnetic region 40 of stylet 10. In certain embodiments, core element 60 may be formed by initially including a magnetic material within core element 60 in magnetic region 40. Optionally, core element 60 may be formed by magnetizing a select portion (*i.e.*, magnetic region 40) of core element 60. Advantageously, magnetizing a select portion of exemplary stylet 10 (*e.g.*, support element 80, core element 60, or both), as opposed to housing a plurality of magnetic elements 70 within a tubular member, may provide a greater amount of flexibility to exemplary stylet 10.

[0067] FIG. 13 is a partial cross-sectional side view of an exemplary stylet 10 according to an additional embodiment. As seen in this figure, exemplary stylet 10 may

comprise an elongated core element 60, a support element 80 circumferentially disposed about at least a portion of core element 60, and a tubular member 54 circumferentially disposed about at least a portion of both support element 80 and core element 60. In at least one embodiment, at least a portion of tubular member 54 may be magnetic. For example, as illustrated in FIG. 13, tubular member 54 may comprise a non-magnetic portion 57 and a magnetic portion 59. As with core element 60, the magnetic portion 59 of tubular member 54 may be formed of any type or form of magnetic material.

[0068] FIG. 14 is a partial cross-sectional side view of an exemplary stylet 10 according to an additional embodiment. As seen in this figure, exemplary stylet 10 may comprise an elongated core element 60, a support element 80 circumferentially disposed about at least a portion of core element 60, and a tubular member 54 circumferentially disposed about at least a portion of both support element 80 and core element 60. In at least one embodiment, and as illustrated in FIG. 14, at least a portion of tubular member 54 may be at least partially melted to flow between adjacent portions (*e.g.*, coils) of support element 80. As used herein, the term “melt” broadly refers to any process or method in which the glass transition temperature of tubular member 54 is exceeded. In certain embodiments, tubular member 54, when at least partially melted, may be formed or shaped by a mold or mandrel.

[0069] FIG. 15 is a partial cross-sectional side view of an exemplary stylet 10 according to an additional embodiment. As seen in this figure, exemplary stylet 10 may comprise an elongated core element 60 and a support element 80 circumferentially disposed about at least a portion of core element 60. In at least one embodiment, core element 60 may comprise a first region 63, a second region 66, and a transition region 64 extending between first region 63 and second region 66. As seen in FIG. 15, second region 66 may have a second diameter $D2$ that is smaller than a first diameter $D1$ of first region 63. In certain embodiments, transition region 64, second region 66, or both may be formed by centerless grinding or any other processes known in the art. In another embodiment, first region 63 and second region 66 may be separate elements coupled or connected to one another. In addition, regions 63, 64, and 66 may each represent separate elements that may be coupled or connected to one another. Advantageously, the reduced diameter of second region 66, which may be provided proximate a distal region

20 of stylet 10, may exhibit increased flexibility to enable stylet 10 to traverse an arcuate subcutaneous path within a patient.

[0070] FIG. 16 is a partial cross-sectional side view of an exemplary stylet 10 according to an additional embodiment. As seen in this figure, exemplary stylet 10 may comprise an elongated core element 60 and a support element 80 circumferentially disposed about at least a portion of core element 60. As with the exemplary embodiment illustrated in FIG. 15, core element 60 may comprise a first region 63, a second region 66 having a diameter that is less than the diameter of first region 63, and a transition region 64 extending between first region 63 and second region 66. In addition, exemplary stylet 10 may comprise one or more magnetic elements 70 circumferentially disposed about second region 66. In at least one embodiment, magnetic elements 70 may be generally cylindrical and/or toroidal in shape. Additionally, a weld element 30 may be provided at the distal end 16 of stylet 10 to position magnetic elements 70 around second region 66 of core element 60. In additional embodiments, magnetic elements 70 may be coupled to second region 66 by, for example, adhesives, threads, pins, or other suitable attachment means.

[0071] FIG. 17 is a partial cross-sectional side view of an exemplary stylet 10 according to an additional embodiment. As seen in this figure, exemplary stylet 10 may comprise an elongated core element 60 and a support element 80 circumferentially disposed about at least a portion of core element 60. As with the exemplary embodiments illustrated in FIGS. 15 and 16, core element 60 may comprise a first region 63, a second region 66 having a diameter that is less than the diameter of first region 63, and a transition region 64 extending between first region 63 and second region 66. In at least one embodiment, a magnetic material may be press-fit or sintered to core element 60 about second region 66. For example, as illustrated in FIG. 17, a magnetic slug 74 may be press-fit or sintered to core element 60 in second region 66. In certain embodiments, one or more grooves 75 may be defined along the outer surface of magnetic slug 74 to provide a desired level of flexibility to magnetic slug 74. Similar to grooves 97, grooves 75 may be formed in any number of shapes and sizes. Examples of grooves 75 include, without limitation, circumferential grooves, longitudinally extending grooves, helical grooves, holes, or other suitable features.

[0072] FIGS. 18 and 19 are partial cross-sectional side views of an exemplary stylet 10 according to an additional embodiment. As seen in FIG. 18, exemplary stylet 10 may comprise an elongated core element 60, a tubular member 54 circumferentially disposed about at least a portion of core element 60, and a plurality of magnetic elements 70 housed within tubular member 54. In at least one embodiment, at least one magnetic element 70 may be coupled to core element 60 by deforming, pressing, sintering, melting, or otherwise attaching at least a portion of tubular member 54 to both core element 60 and magnetic element 70. In addition, as illustrated in FIG. 19, tubular member 54 may be positioned at least partially between adjacent magnetic elements 70 to maintain the longitudinal separation (*i.e.*, gaps 52) between adjacent magnetic elements 70.

[0073] FIG. 20 is a partial cross-sectional side view of an exemplary stylet 10 according to an additional embodiment. As seen in this figure, exemplary stylet 10 may comprise an elongated core element 60 comprising a first region 63, a second region 66 having a diameter that is less than the diameter of first region 63, and a transition region 64 extending between first region 63 and second region 66. In at least one embodiment, a coating 76 may be circumferentially disposed about at least a portion of core element 60 (*e.g.*, distal region 56 of core element 60). Coating 76 may also be circumferentially disposed about one or more magnetic elements 70 to effectively couple magnetic elements 70 to core element 60. Coating 76, which generally represents any type or form of coating material, may be formed of any number or combination of materials; including, for example, polymers (such as polyimide, silicone, or so-called heat shrink tubing), metal, or other suitable materials. In general, coating 76 may be disposed about core element 60 and/or magnetic elements 70 by spraying, molding, dipping, or otherwise affixing coating 76 to core element 60 and/or magnetic elements 70. In certain embodiments, coating 76 may comprise a pliant material to impart a desired level of flexibility or rigidity to a distal region of stylet 10.

[0074] FIG. 21 is a partial cross-sectional side view of an exemplary stylet 10 according to an additional embodiment. As seen in this exemplary embodiment, exemplary stylet 10 may comprise an elongated core element 60, a helical member 24 circumferentially disposed about at least a portion of core element 60, and a plurality of magnetic elements 70 housed within helical member 24. Generally speaking, helical

member 24 represents any type or form of structure capable of helically surrounding at least a portion of core element 60 and/or magnetic elements 70. In at least one embodiment, helical member 24 may be affixed to core element 60, magnetic elements 70, or both. In certain embodiments, the helical configuration and material comprising helical member 24 may provide a desired level of flexibility to stylet 10. In addition, as illustrated in FIG. 21, core element 60 may also comprise a so-called mandrel having an enlarged distal end 68.

[0075] FIG. 22 is a partial cross-sectional side view of an exemplary stylet 10 according to an additional embodiment. As seen in this figure, exemplary stylet 10 may comprise an elongated core element 60, a tubular member 54 positioned proximate a distal region 20 of stylet 10, and a plurality of magnetic elements 70 housed within tubular member 54. In at least one embodiment, a support element 80 may be circumferentially disposed about substantially the entire lengths of both core element 60 and tubular member 54 to effectively couple tubular member 54 (and magnetic elements 70 housed therein) to core element 60. A weld element 30 may also be provided proximate the distal end 16 of stylet 10 to effectively retain magnetic elements 70 within tubular member 54. In certain embodiments, support element 80 may be welded or otherwise affixed to weld element 30.

[0076] FIG. 23 is a partial cross-sectional side view of an exemplary stylet 10 according to an additional embodiment. As seen in this figure, exemplary stylet 10 may comprise an elongated core element 60, a support member 80 circumferentially disposed about at least a portion of core element 60, a tubular member 54 circumferentially disposed about substantially the entire lengths of core element 60 and support member 80, and a plurality of magnetic elements 70 housed within tubular member 54 proximate a distal region of stylet 10. As with the exemplary embodiments illustrated in FIGS. 15-17, core element 60 may comprise a first region 63, a second region 66 having a diameter that is less than the diameter of first region 63, and a transition region 64 extending between first region 63 and second region 66. As with previous embodiments, magnetic elements 70 may be positioned about second region 66 of core element 60. In addition, in at least one embodiment, one or more spacing elements 92 may be positioned longitudinally between adjacent magnetic elements 70. Spacing elements 92, which may be formed of any number or combination of materials, generally represent

any type or form of structure capable of separating longitudinally adjacent magnetic elements 70. In certain embodiments, a weld element 30 may be provided proximate distal end 16 to effectively retain magnetic elements 70 and spacing elements 92 within tubular member 54 and around second region 66 of core element 60.

[0077] FIG. 24 is a partial cross-sectional side view of an exemplary stylet 10 according to an additional embodiment. As seen in this figure, exemplary stylet 10 may comprise an elongated core element 60, a support member 80 circumferentially disposed about at least a portion of core element 60, a tubular member 54 circumferentially disposed about substantially the entire lengths of core element 60 and support member 80, and a plurality of magnetic elements 70 housed within tubular member 54 proximate a distal region of stylet 10. As with previous embodiments, a capture element 62 may be provided proximate distal end 16 to effectively retain magnetic elements 70 within tubular member 54. In at least one embodiment, a protective coating 78 may be applied the proximal and distal surfaces of each magnetic element 70. Protective coating 78, which may be formed of any number or combination of materials, generally represents any type of material capable of preventing direct contact between adjacent magnetic elements 70. In certain embodiments, protective coating 78 may be applied to magnetic elements 70 so as to form an arcuate shape on the proximal and distal ends of magnetic elements 70 to facilitate the bending of a distal region of stylet 10. As with previous embodiments, and as discussed in greater detail above, interstitial space 44 may be filled with a filler material, such as silicone, rubber, fluid, or other suitable material.

[0078] FIG. 25 is a partial cross-sectional side view of an exemplary stylet 10 according to an additional embodiment. As seen in this figure, exemplary stylet 10 may comprise an elongated core element 60, a tubular member 54 circumferentially disposed about core element 60 and extending from proximate end 14 to distal end 16 of stylet 10, a plurality of magnetic elements 70 housed within tubular member 54 proximate a distal region of stylet 10, and a support member 80 circumferentially disposed about substantially the entire lengths of both tubular member 54 and core element 60. As with previous embodiments, a weld element 30 may be provided proximate distal end 16 of stylet 10 to effectively retain magnetic elements 70 within tubular member 54.

[0079] FIG. 26 is a partial cross-sectional side view of an exemplary stylet 10 according to an additional embodiment. As seen in this figure, exemplary stylet 10 may

comprise an elongated core element 60 having a first region 63, a second region 66 having a diameter that is less than the diameter of first region 63, and a transition region 64 extending between first region 63 and second region 66. In at least one embodiment, a magnetic coating 72 may be disposed about at least a portion of core element 60. For example, as illustrated in FIG. 26, magnetic coating 72 may be disposed over second region 66 of core element 60. In additional embodiments, magnetic coating 72 may extend over any portion of core element 60, including its entire length, without limitation.

[0080] FIG. 27 is a partial cross-sectional side view of an exemplary stylet 10 according to an additional embodiment. As seen in this figure, exemplary stylet 10 may comprise first and second elongated core element portions 60 and one or more magnetic elements 70 and disposed between these core element portions 60. In at least one embodiment, a tubular member 54 may be circumferentially disposed about magnetic elements 70 and at least a portion of each core element portion 60 to effectively retain magnetic elements 70 within stylet 10. In certain embodiments, a support member 80 may also be circumferentially disposed about at least a portion of each core element portion 60.

[0081] FIG. 28 is a partial cross-sectional side view of an exemplary stylet 10 according to an additional embodiment. As seen in this figure, exemplary stylet 10 may comprise an elongated core element 60, a tubular member 54 circumferentially disposed about core element 60 and extending substantially the entire length of stylet 10 (*i.e.*, from proximate end 14 to distal end 16 of stylet 10), and a plurality of magnetic elements 70 housed within tubular member 54 proximate a distal region of stylet 10. In at least one embodiment, tubular member 54 may be adhered or otherwise affixed directly to at least a portion of core element 60 and magnetic elements 70 to effectively couple magnetic elements 70 to core element 60. In an additional embodiment, a matrix material 88 may be disposed between core element 60, tubular member 54, and/or adjacent magnetic elements 70. Matrix material 88 generally represents any type or form of material, such as a suspension or slurry, capable of being disposed between core element 60, tubular member 54, and/or adjacent magnetic elements 70. Matrix material 88 may be formed of any number or combination of materials; including, for example, cyanoacrylate, epoxy, polyurethane, urethane, photopolymers, heat-curable materials, silicone, rubber, or any

other suitable material, without limitation. In at least one embodiment, matrix material 88 may act as a filler, stabilizer, adhesive, or the like. In addition, in certain embodiments, matrix material 88 may form a rounded end 86 proximate distal end 16 of stylet 10 to effectively retain magnetic elements 70 within tubular member 54.

[0082] FIG. 29 is a partial cross-sectional side view of an exemplary stylet 10 according to an additional embodiment. As seen in this figure, exemplary stylet 10 may comprise an elongated core element 60, a tubular member 54 circumferentially disposed about core element 60 and extending substantially the entire length of stylet 10 (*i.e.*, from proximate end 14 to distal end 16 of stylet 10), and a single elongated magnetic element 70 housed within tubular member 54 proximate distal region 20 of stylet 10. As with tubular member 54, magnetic element 70 may be configured to exhibit a desired level of stiffness or flexibility. In certain embodiments, tubular member 54 may be adhered or otherwise affixed directly to at least a portion of core element 60 and/or magnetic element 70 to effectively couple magnetic element 70 to core element 60. In an additional embodiment, a matrix material 88 may be disposed between tubular member 54, core element 60, and/or magnetic element 70.

[0083] FIG. 30 is a partial cross-sectional side view of an exemplary stylet 10 according to an additional embodiment. As seen in this figure, exemplary stylet 10 may comprise an elongated core element 60, a tubular member 54 circumferentially disposed about core element 60 and extending substantially the entire length of stylet 10 (*i.e.*, from proximate end 14 to distal end 16 of stylet 10), and a plurality of magnetic elements 70 housed within tubular member 54 proximate distal region 20 of stylet 10. In at least one embodiment, core element 60 may comprise a so-called mandrel having an enlarged leading end 68. A closure element 31 forming a generally rounded end 86 may also be provided proximate the distal end 16 of stylet 10 to effectively retain magnetic elements 70 within tubular member 54. Closure element 31 may be affixed or otherwise attached to tubular member 54 in any number of ways; including, for example, by welding, bonding, adhering, or otherwise mechanically affixing closure element 31 to tubular member 54. Closure element 31 may also be formed of one or more adhesive materials, such as epoxy, and bonded to the tubular member 54.

[0084] In certain embodiments, a tubular sleeve 94 may be circumferentially disposed about and mechanically or chemically coupled to both the enlarged leading end

68 of core element 60 and at least one of magnetic elements 70 to effectively couple magnetic elements 70 to core element 60. Tubular sleeve 94 generally represents any type or form of material capable of being circumferentially disposed about core element 60 and/or at least one magnetic element 70. In certain embodiments, tubular sleeve may comprise a material that contracts or reduces in size (*i.e.*, “shrinks”) when heated to effectively couple one or more magnetic elements 70 to core element 60. In at least one embodiment, exemplary stylet 10 may be assembled by disposing tubular sleeve 94 about the enlarged leading end 68 of core element 60 and contracting (*e.g.*, by applying heat to a select portion of tubular sleeve 94 using, for example, a heat gun) at least a portion of tubular sleeve 94 about enlarged leading end 68. In addition, magnetic elements 70 may be retained within tubular sleeve 94 by contracting at least a portion of tubular sleeve 94 (*e.g.*, by applying heat to at least a portion of tubular sleeve 94) about magnetic elements 70. In additional embodiments, tubular sleeve 94 may be configured to contract about (*i.e.*, circumferentially engage) at least a portion of closure element 31 without engaging magnetic elements 70.

[0085] FIGS. 31-34 are partial cross-sectional end views of exemplary stylets 10. As illustrated in these figures, stylet 10 may comprise one or more elongated core elements 60. For example, stylet 10 may comprise a single core element 60 (FIG. 31), two core elements 60 (FIG. 32), three core elements 60 (FIG. 33), four core elements 60 (FIG. 34), or more. In certain embodiments, each core element 60 in exemplary stylet 10 may be formed so as to be substantially identical to one another. In additional embodiments, each core element 60 in stylet 10 may be structurally unique. In addition, in any of the above-described exemplary embodiments, one or more than one core element 60 may comprise a magnetic portion. Advantageously, by employing a plurality of core elements 60 having unique magnetic configurations, a user may be able to precisely identify the location of distal region 20 of stylet 10 along select x, y, and z axes (*i.e.*, pitch, yaw, and roll).

[0086] FIG. 35 is a partial cross-sectional end view of an exemplary catheter assembly 100 according to at least one embodiment. As illustrated in this figure, catheter assembly 100 may comprise a plurality of stylets 10 disposed within a catheter 90. Any number or configuration of stylets 10 may be disposed within catheter 90 of catheter assembly 100, without limitation. For example, catheter assembly 100 may

76186-212

comprise one, two, three, four, or more stylets 10 disposed within exemplary catheter 90. As with the exemplary embodiments illustrated in FIGS. 31-34, each stylet 10 disposed within catheter 90 may be substantially identical to one another, or structurally unique from each other. In addition, by employing a plurality of stylets 10 having unique magnetic element configurations, a user may be able to precisely identify the location of a distal region of catheter 90 along select x, y, and z axes (*i.e.*, pitch, yaw, and roll).

[0087] Although the above-described embodiments show particular configurations of exemplary stylets comprising magnetic materials, such embodiments are exemplary. Accordingly, many different embodiments are contemplated and encompassed by this disclosure. In addition, one or more of the exemplary stylet embodiments described and/or illustrated herein may be at least partially disposed within a lumen of a catheter, cannula, hollow needle, or other suitable device to provide (*i.e.*, impart) increased stiffness or rigidity to the device. For example, as illustrated in FIG. 36, one or more stylets 10 may be positioned within a catheter 90 of a catheter assembly 100 to facilitate the navigation of the catheter 90 within a select portion of a patient. For example, at least one stylet 10 may be inserted into the lumen of a catheter 90, such as a peripherally inserted central catheter (PICC), to help guide catheter 90 into the superior vena cava (SVC) of a patient. Catheter assembly 100 may also be used in connection with other suitable applications, as desired.

[0088] The scope of the claims should not be limited by the preferred embodiments set forth in the examples, but should be given the broadest interpretation consistent with the description as a whole.

76186-212

CLAIMS:

1. A stylet, comprising:

an elongated core element completely surrounded by a polymer member from a proximal end to a distal end thereof, the polymer member extending distal of the core element
5 distal end;

a closure element affixed to a distal end of the polymer member; and

a plurality of magnetic elements disposed distal of the core element distal end and proximal of the closure element, the polymer member surrounding the magnetic elements.
2. The stylet according to claim 1, further comprising a sleeve surrounding the
10 magnetic elements and a distal section of the core element, the sleeve surrounded by the polymer member.
3. The stylet according to claim 2, wherein the sleeve is contracted to engage the magnetic elements and the distal section of the core element.
4. The stylet according to claim 1, wherein the distal section of the core element
15 includes an enlarged end.
5. The stylet according to claim 4, wherein the magnetic elements each have a diameter approximately equal to a diameter of the enlarged end.
6. The stylet according to claim 5, further comprising a sleeve surrounding the magnetic elements and the enlarged end, the sleeve surrounded by the polymer member.
- 20 7. The stylet according to claim 1, wherein the closure element includes a generally rounded distal end.
8. The stylet according to claim 1, wherein the closure element is formed from one or more adhesive materials and is bonded to the polymer member.

76186-212

9. The stylet according to claim 1, wherein adjacent magnetic elements are spaced from one another, creating a gap therebetween.
10. The stylet according to claim 1, wherein the plurality of magnetic elements comprises three or more magnetic elements, each adjacent magnetic element spaced apart by a
5 gap.
11. The stylet according to claim 10, wherein one or more of the gaps are filled with a pliant filling material.
12. The stylet according to claim 10, wherein a portion of the polymer member extends into one or more of the gaps.
- 10 13. The stylet according to claim 1, further comprising a reinforcing member extending along a length of the elongated core element.
14. The stylet according to claim 13, wherein the reinforcing member is integrally formed with the polymer member.
15. The stylet according to claim 1, wherein the polymer member includes a
15 plurality of circumferential grooves spaced from one another along a distal section of the stylet.
16. The stylet according to claim 1, further comprising a matrix material disposed between the core element and polymer member.
17. The stylet according to claim 16, wherein the plurality of magnetic elements
20 comprises three or more magnetic elements, each adjacent magnetic element spaced apart by a gap, the matrix material extending between the gaps and forming the closure element.
18. The stylet according to claim 17, wherein the matrix material is selected from the group consisting essentially of cyanoacrylate, epoxy, polyurethane, urethane, photopolymers, heat-curable materials, silicone, rubber, and combinations thereof.

76186-212

19. A stylet, comprising:

an elongated core element surrounded by a polymer member from a proximal end of the core element to a distal end thereof, the polymer member extending distal of the core element distal end, the polymer member affixed to at least a portion of the core element;

5 a closure element affixed to a distal end of the polymer member; and

a plurality of permanent magnetic elements disposed distal of the core element distal end and proximal of the closure element, the polymer member surrounding the magnetic elements.

20. A catheter assembly, comprising:

10 a catheter defining a lumen; and

the stylet according to any one of claims 1 to 19, at least partially disposed in the catheter lumen.

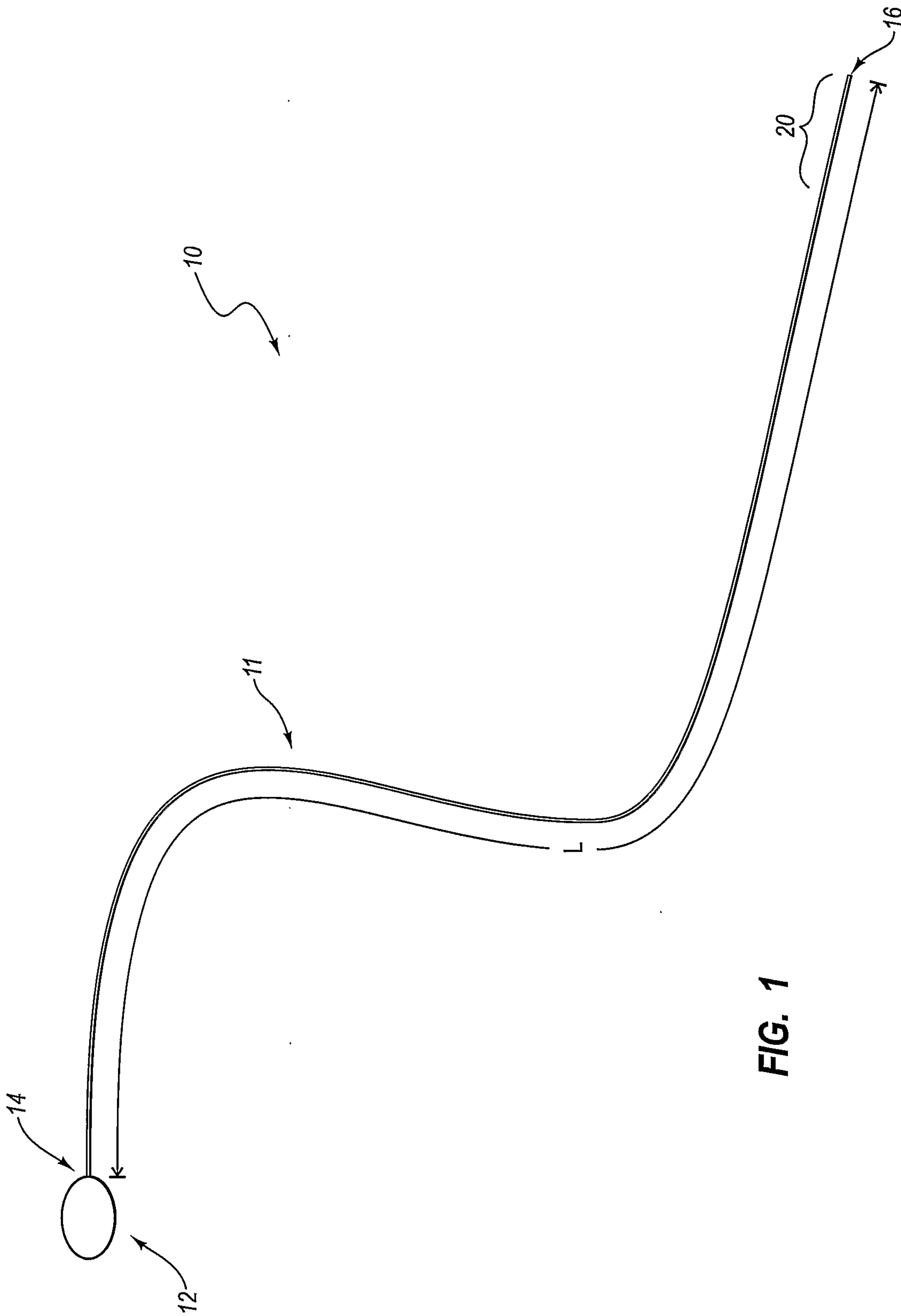

FIG. 1

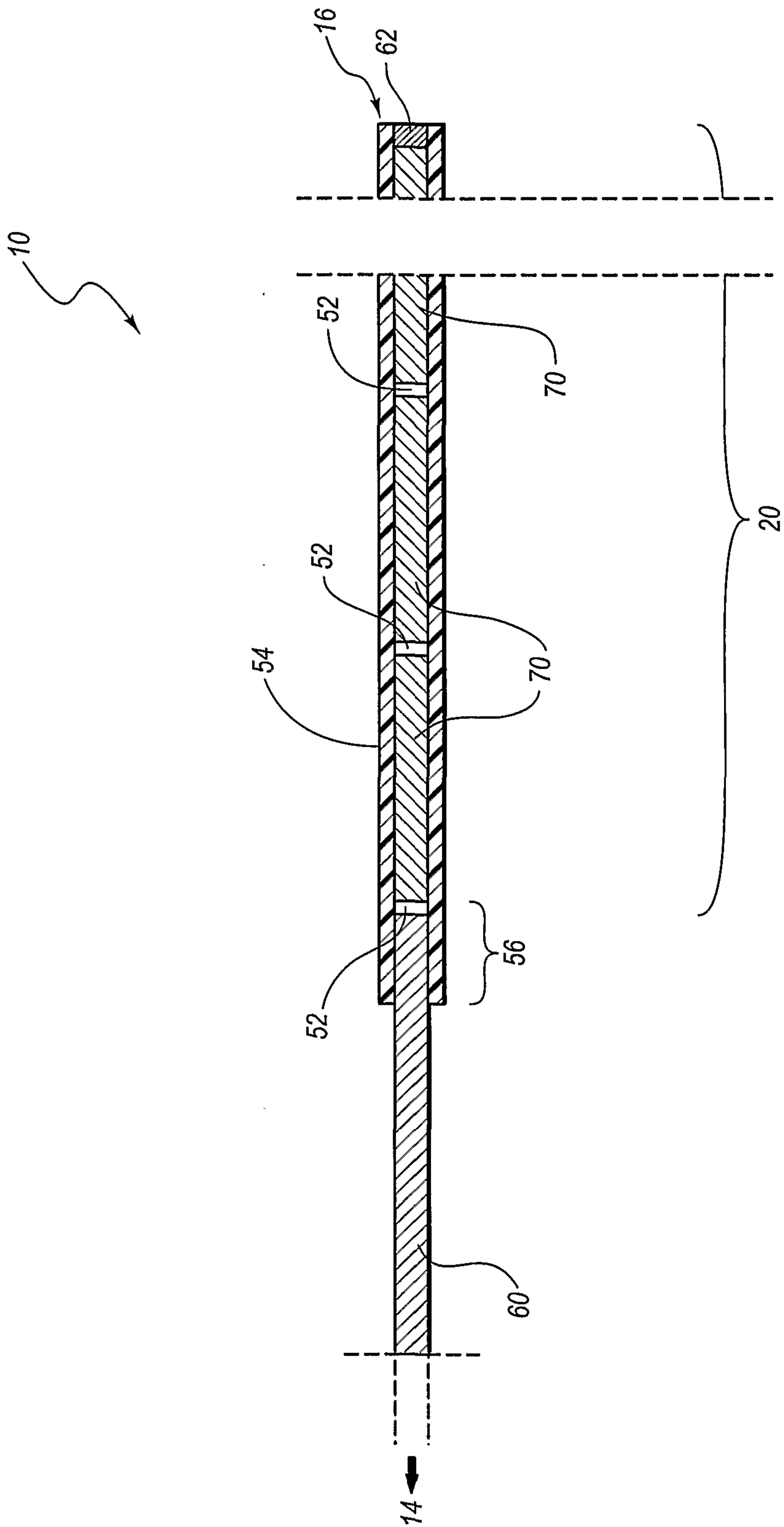

FIG. 2

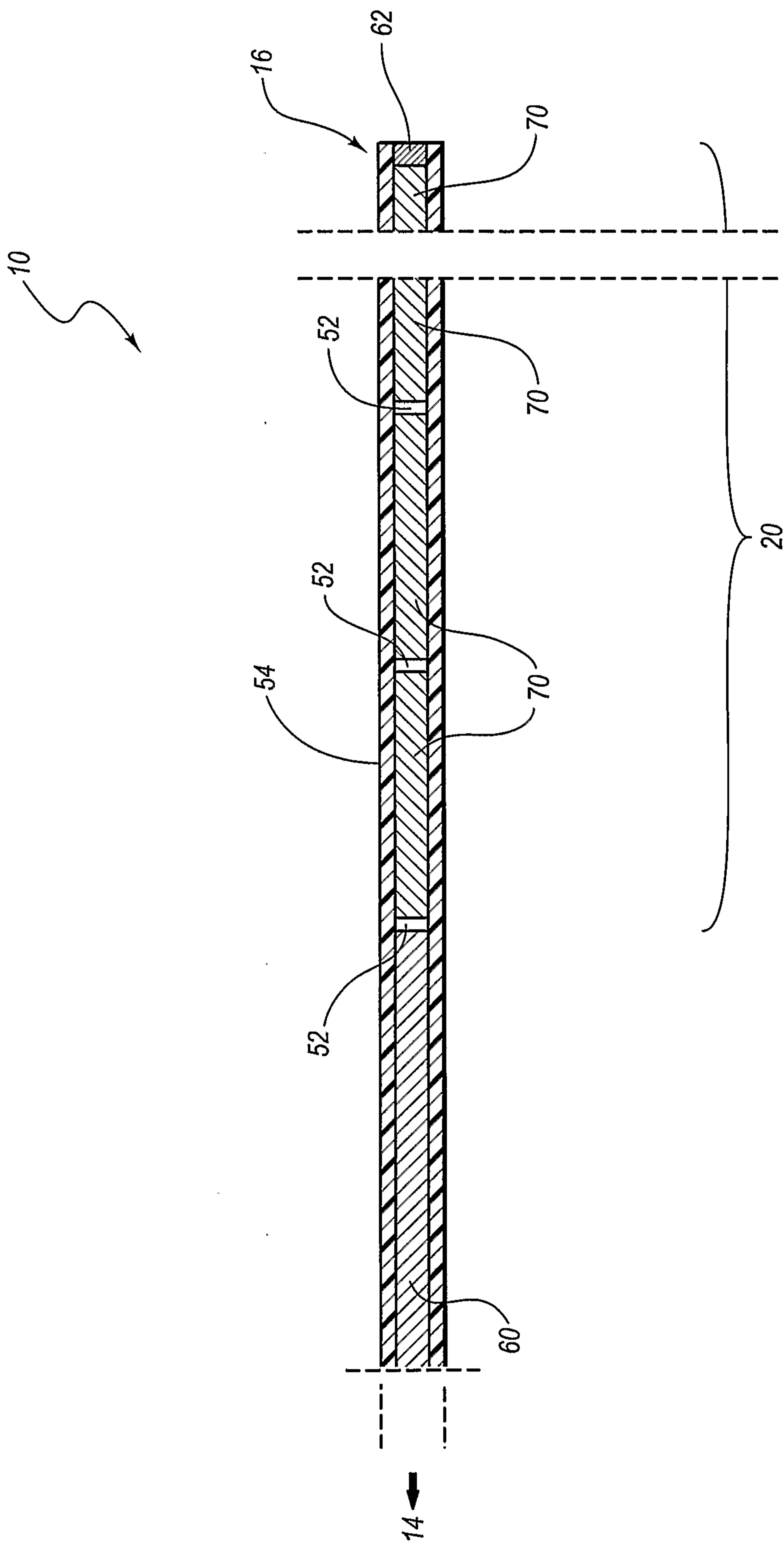

FIG. 3

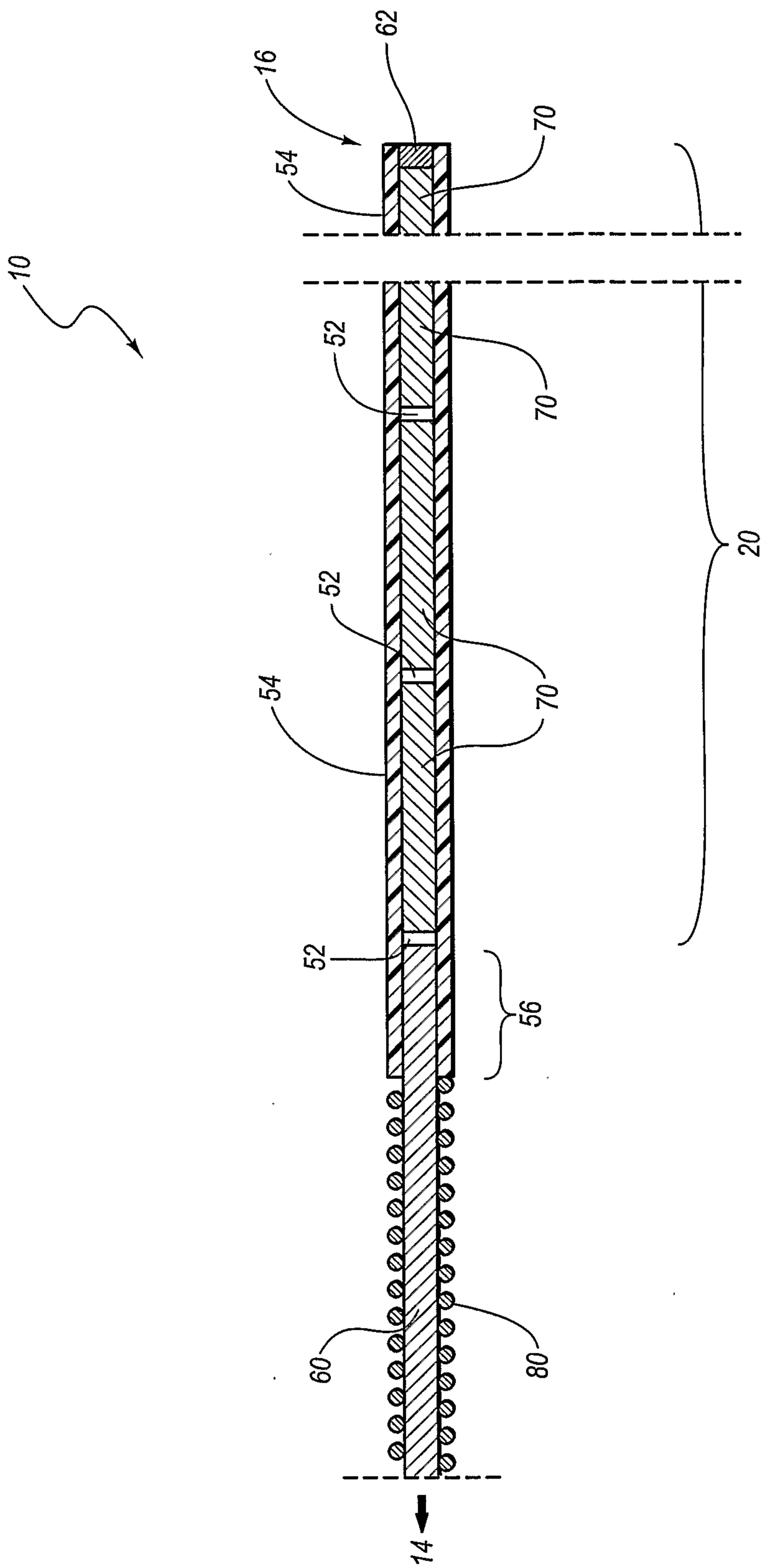

FIG. 4

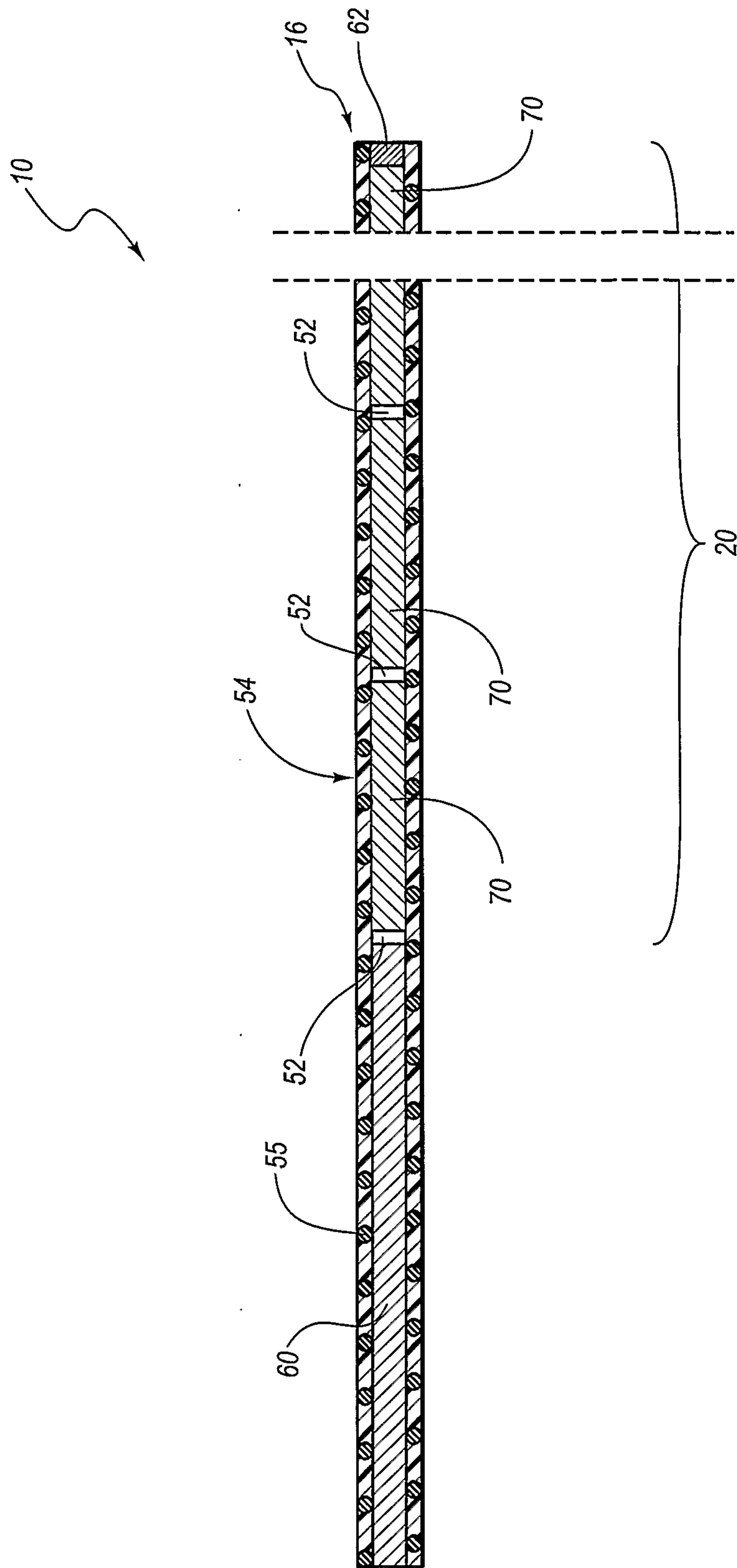

FIG. 5

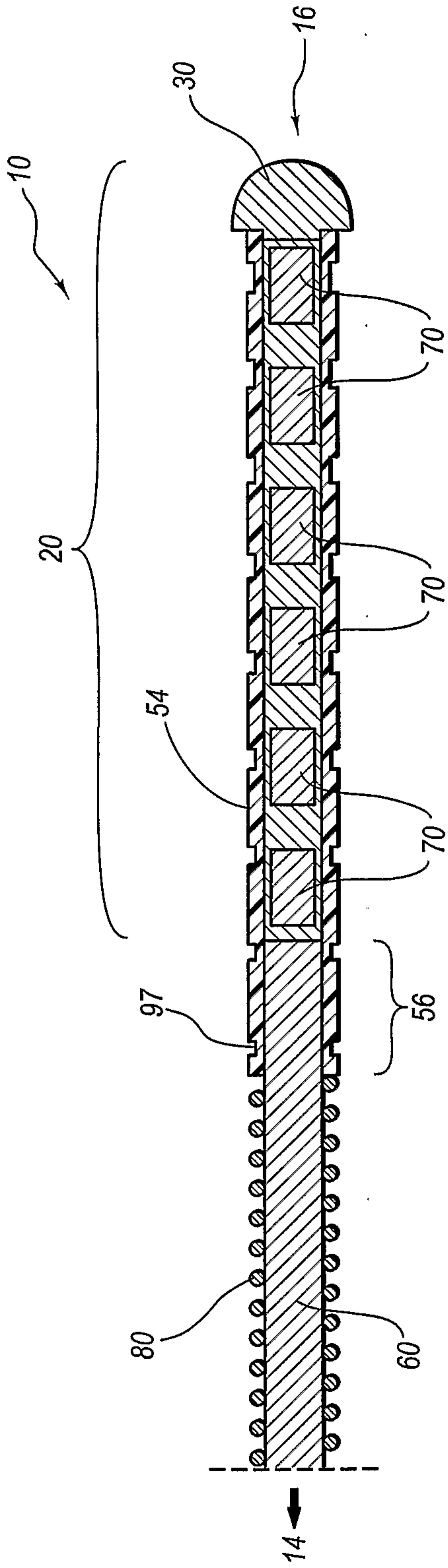

FIG. 6

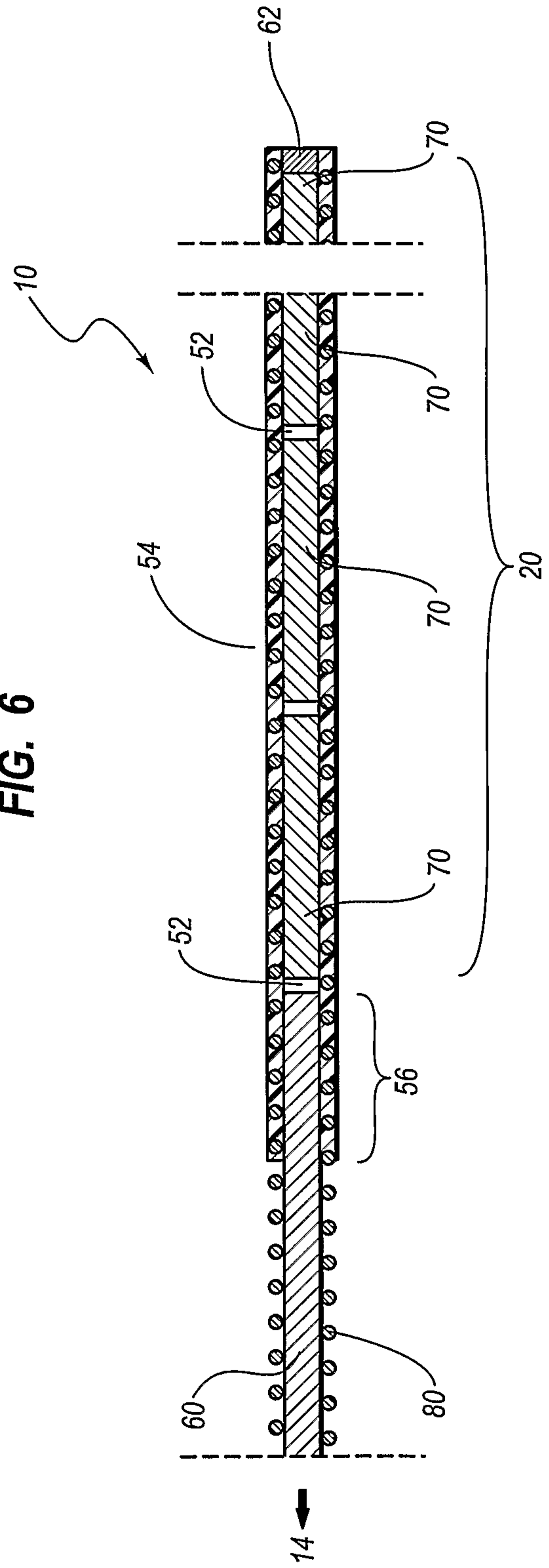

FIG. 7

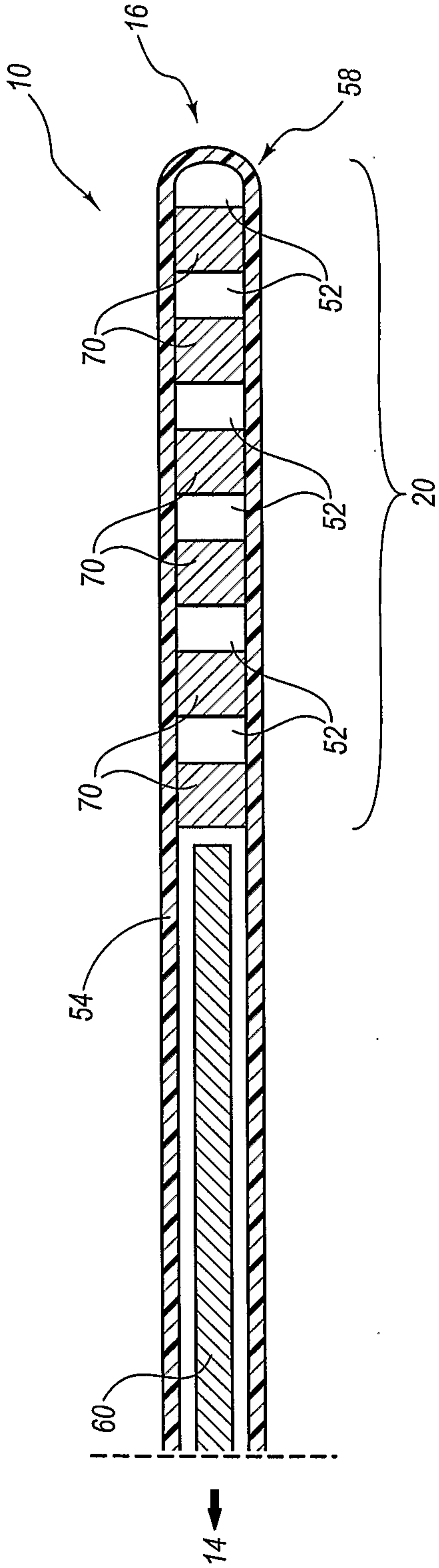

FIG. 8

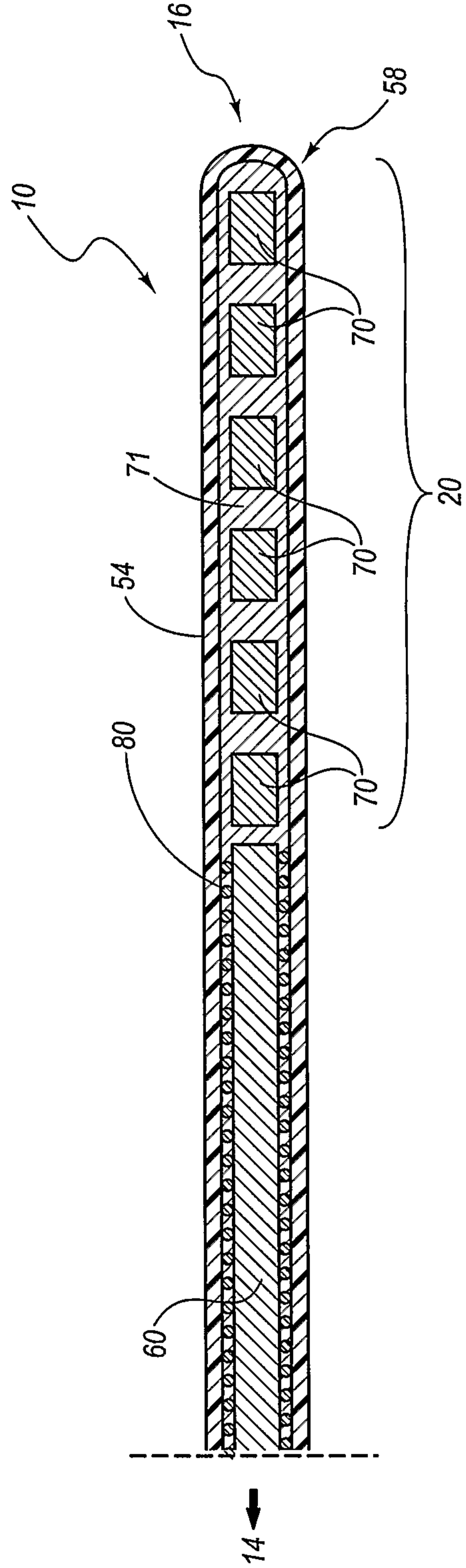

FIG. 9

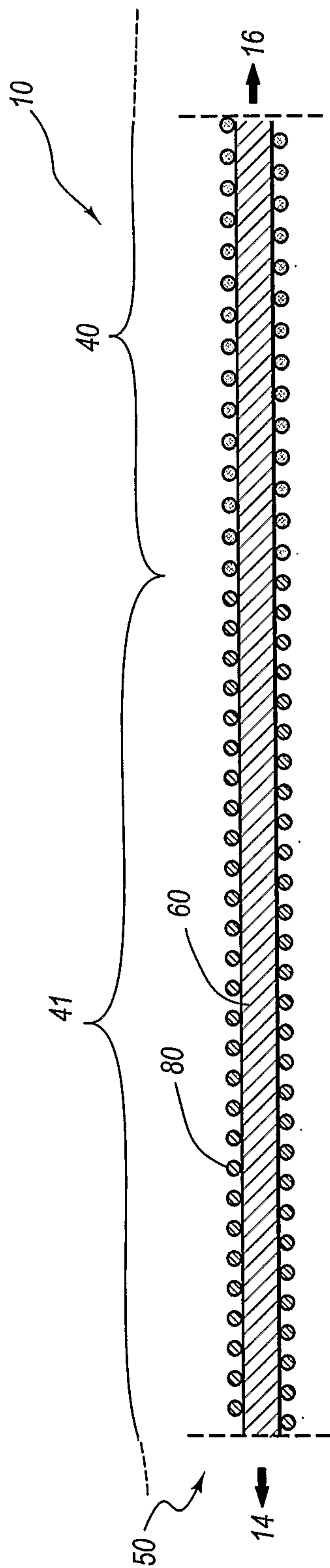

FIG. 10

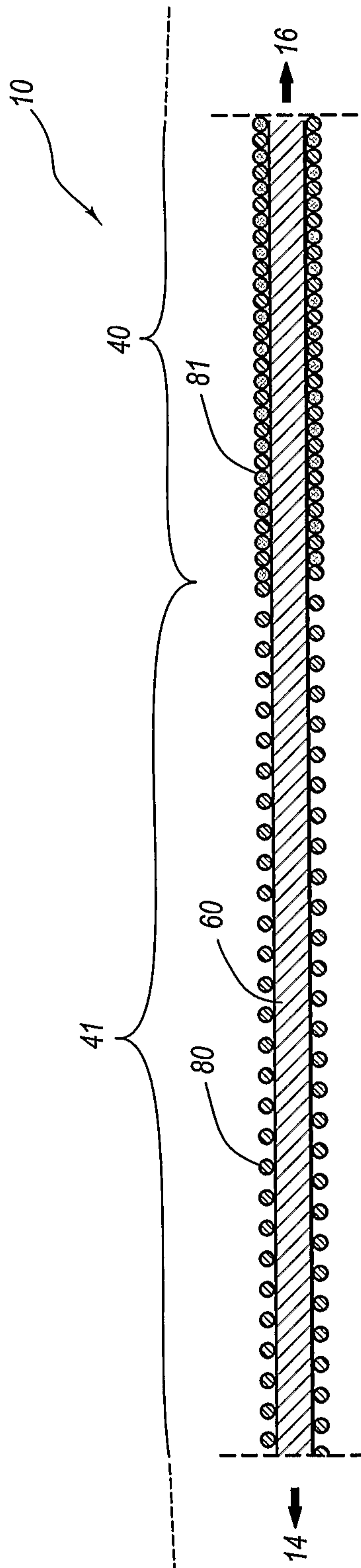

FIG. 11

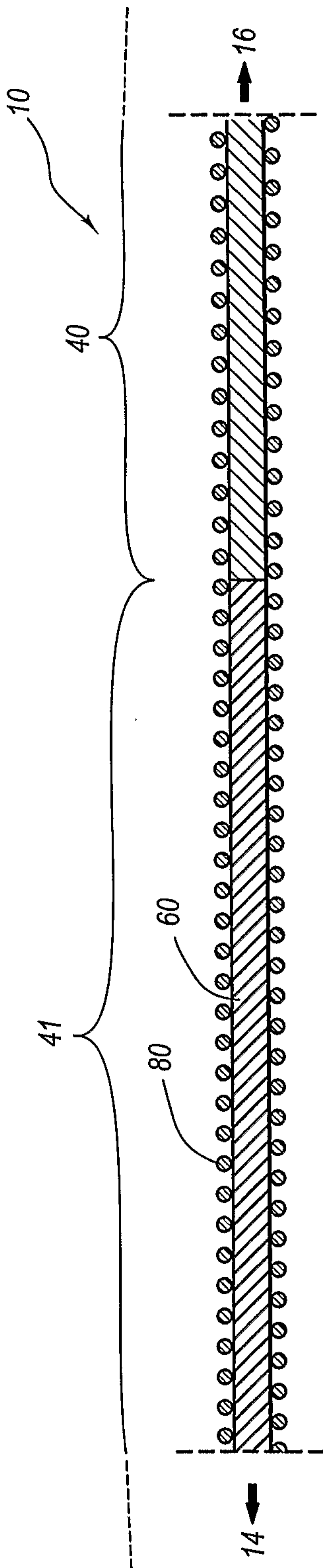

FIG. 12

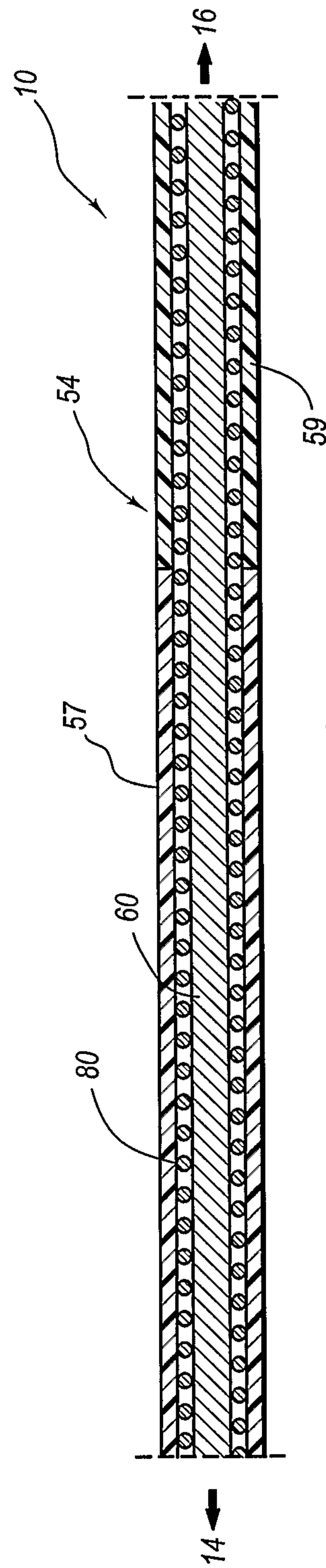

FIG. 13

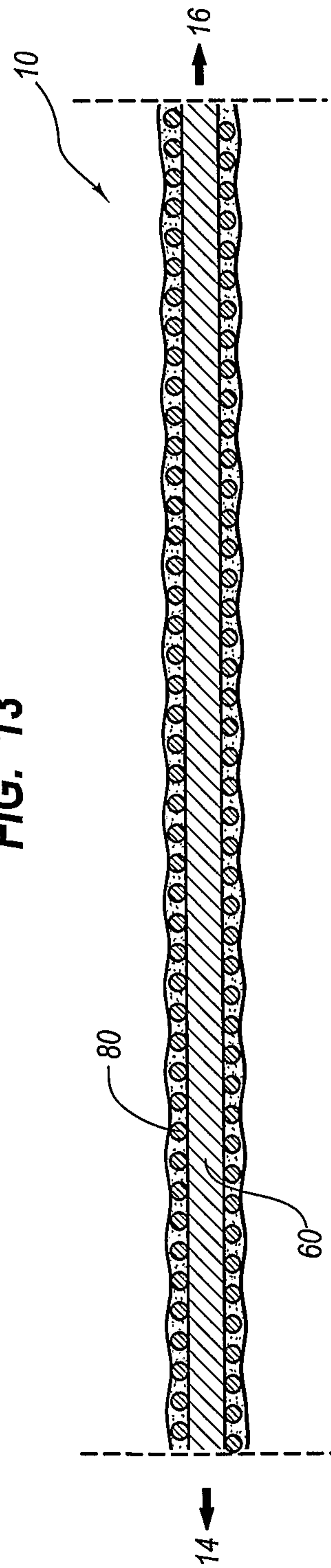

FIG. 14

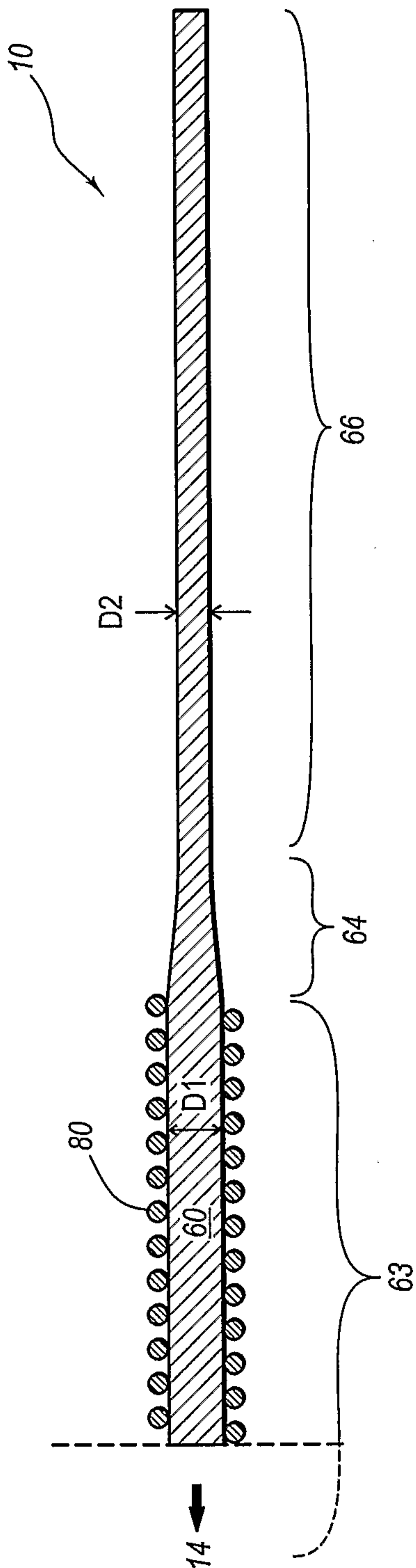

FIG. 15

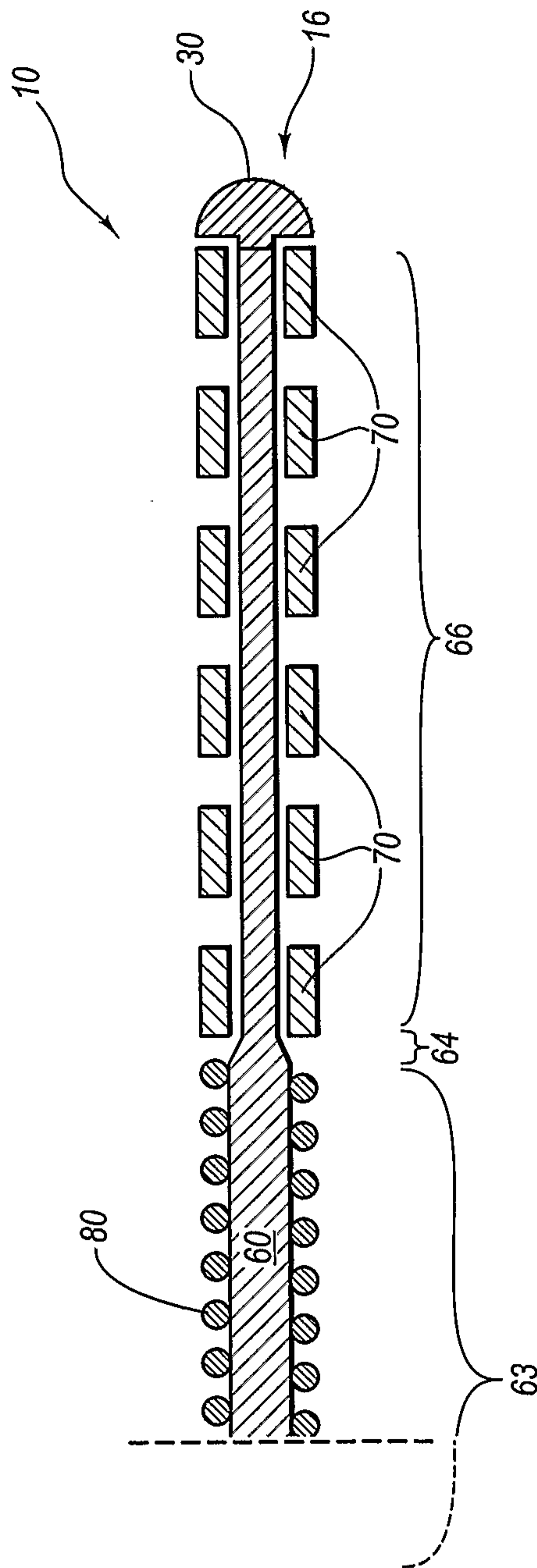

FIG. 16

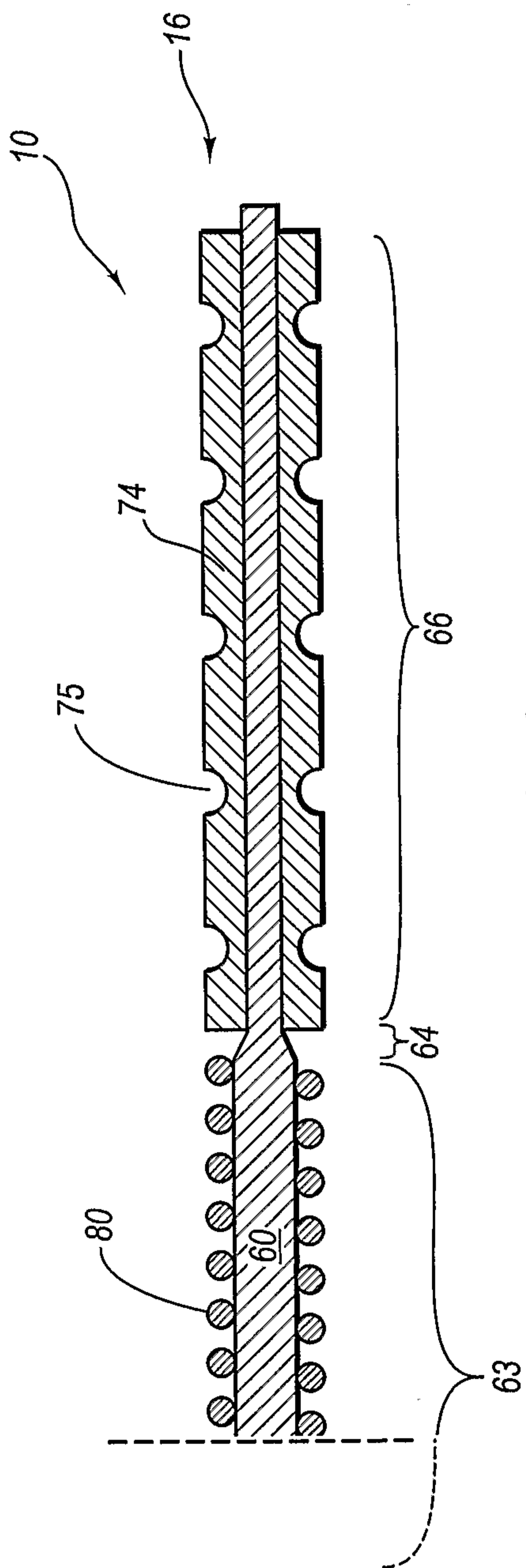

FIG. 17

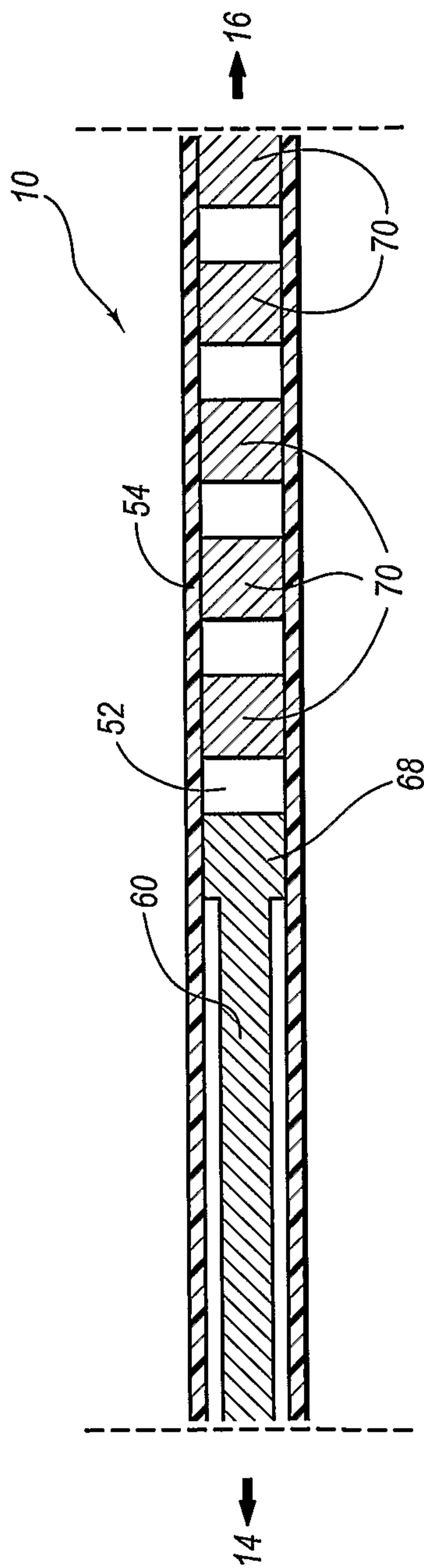

FIG. 18

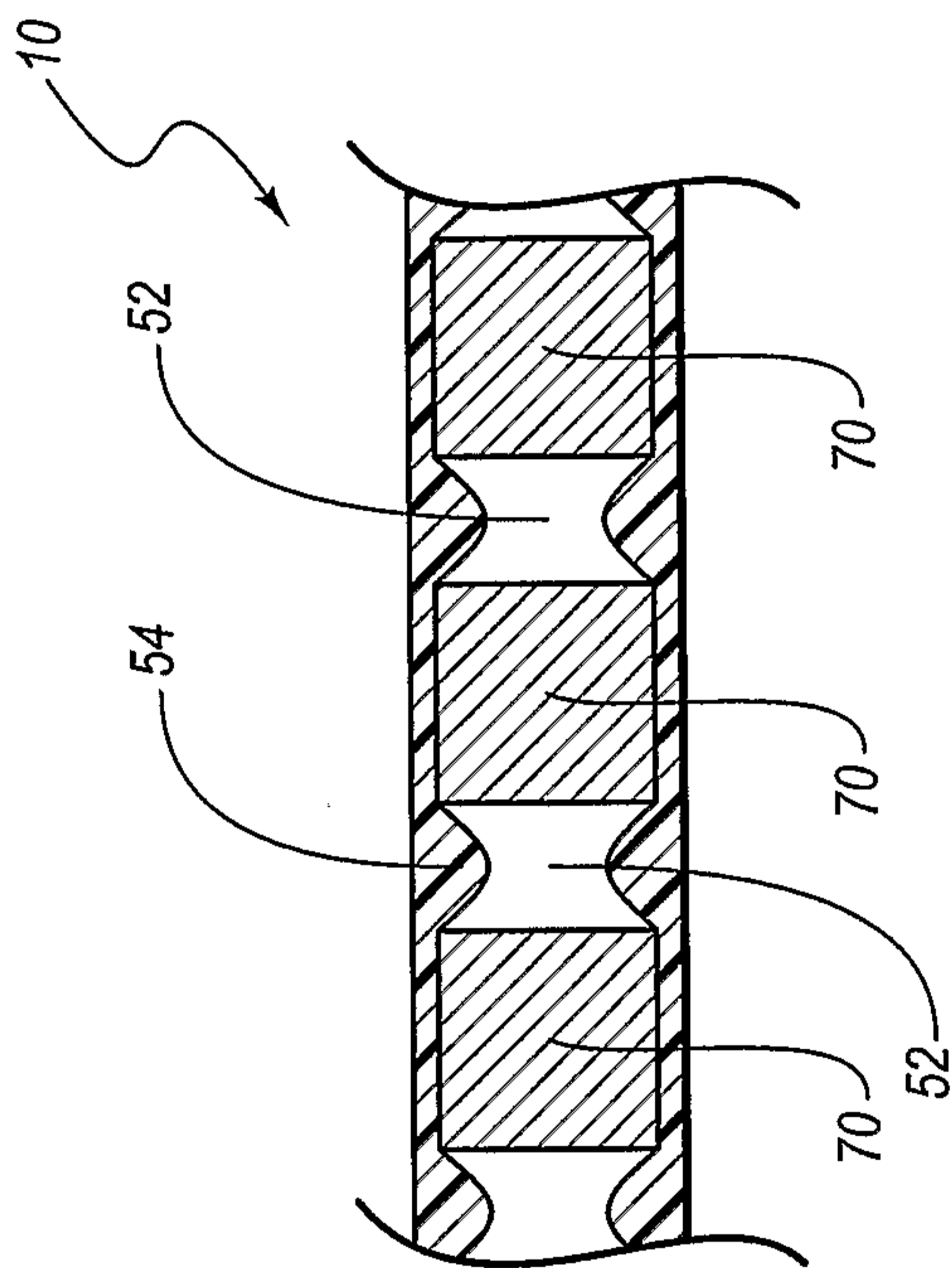

FIG. 19

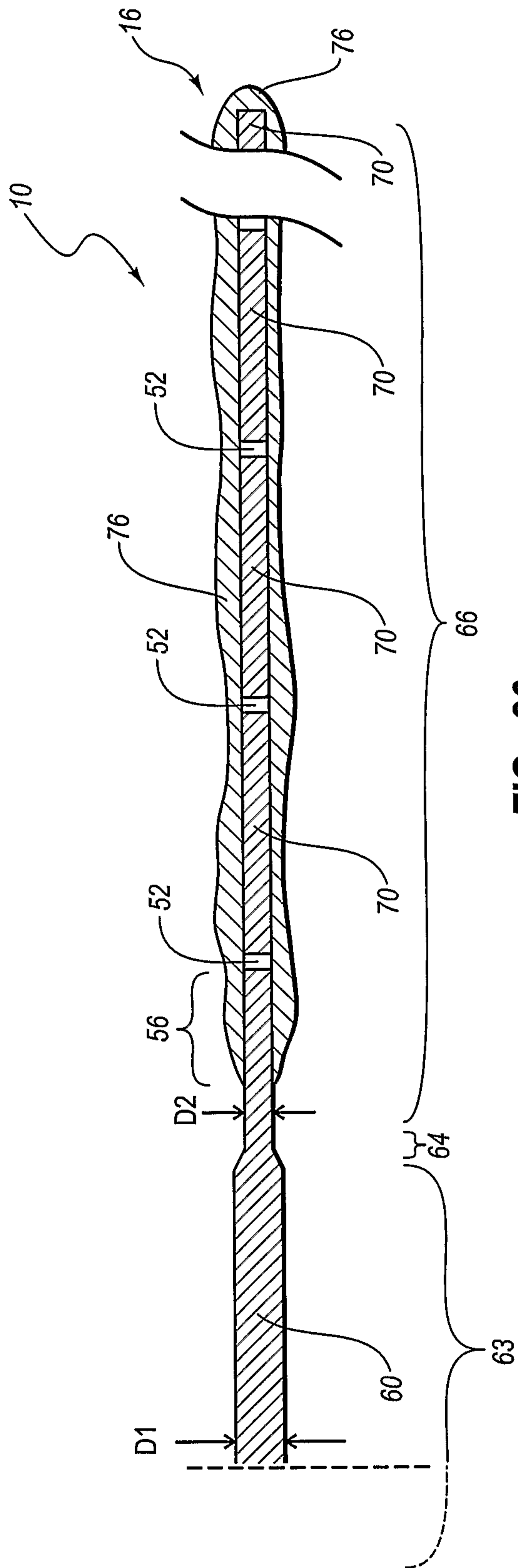

FIG. 20

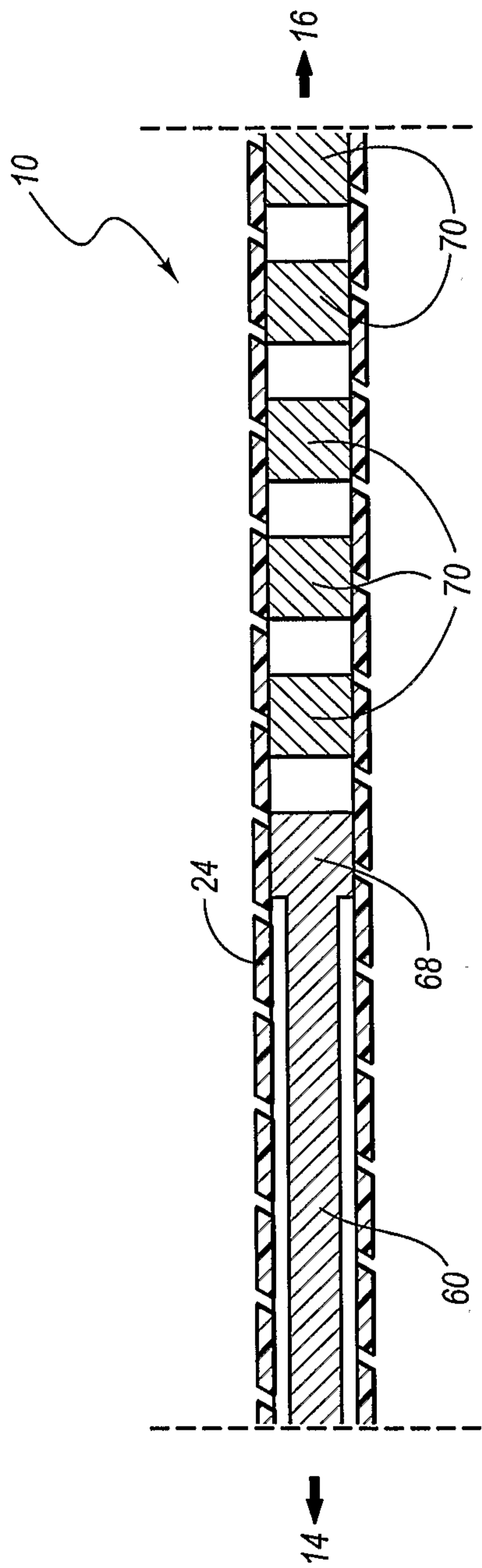

FIG. 21

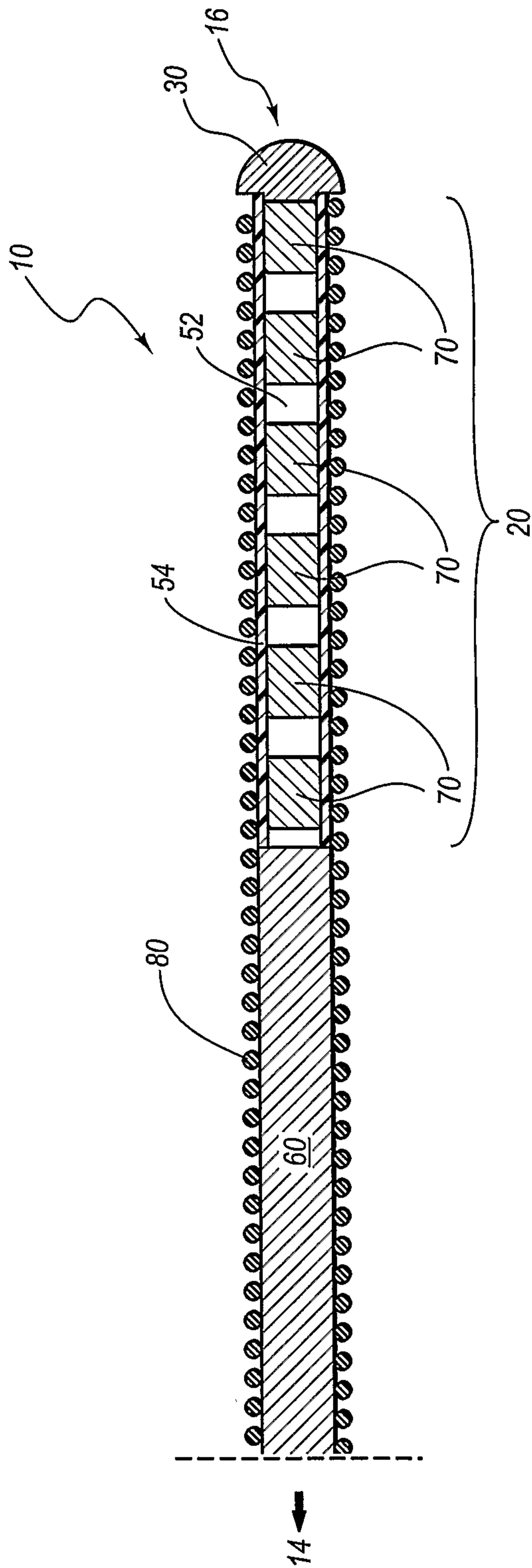

FIG. 22

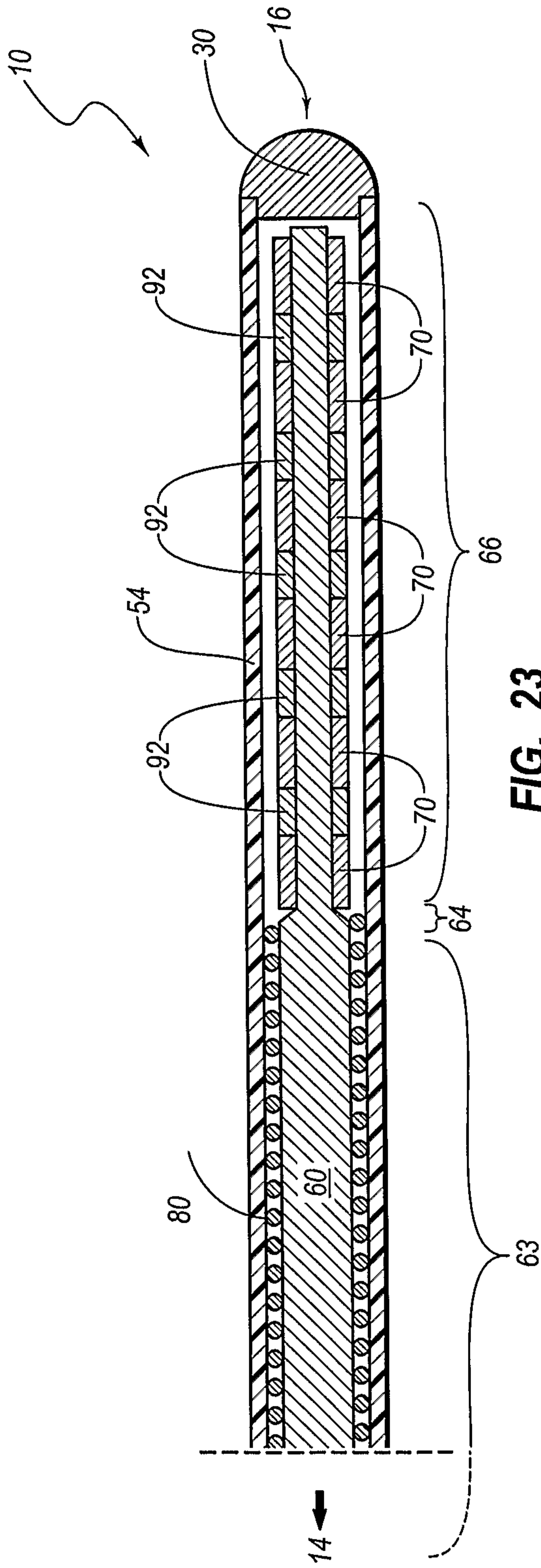

FIG. 23

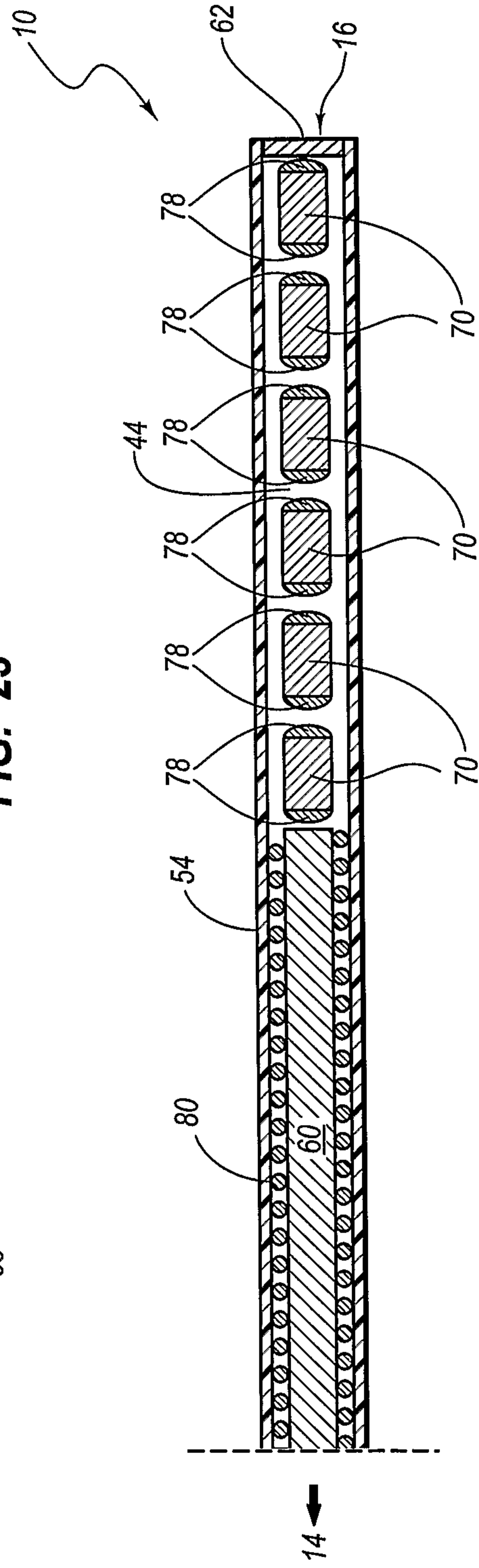

FIG. 24

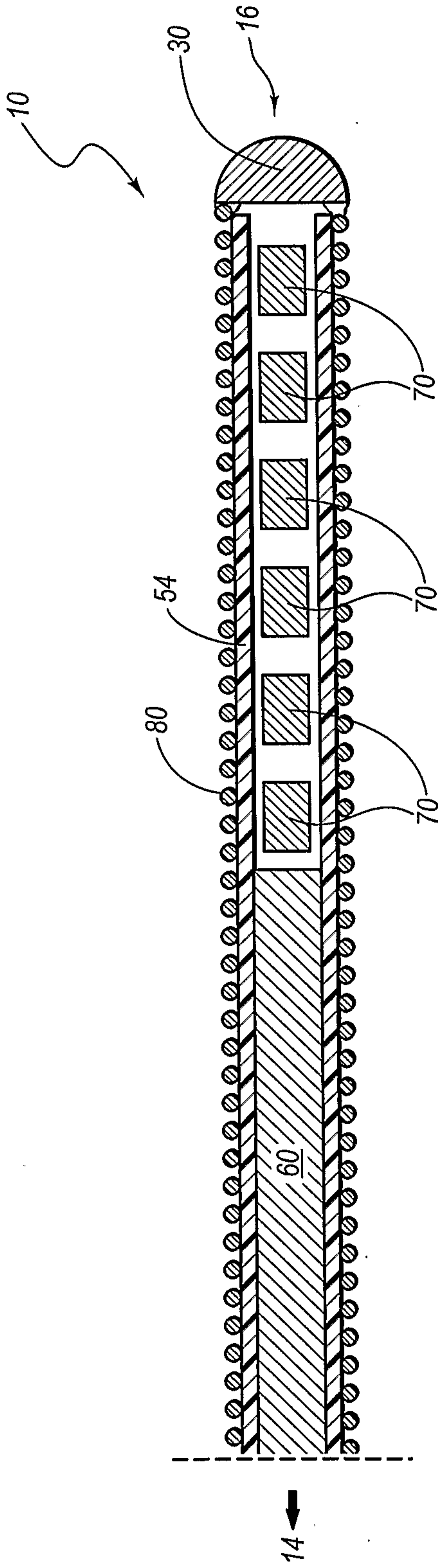

FIG. 25

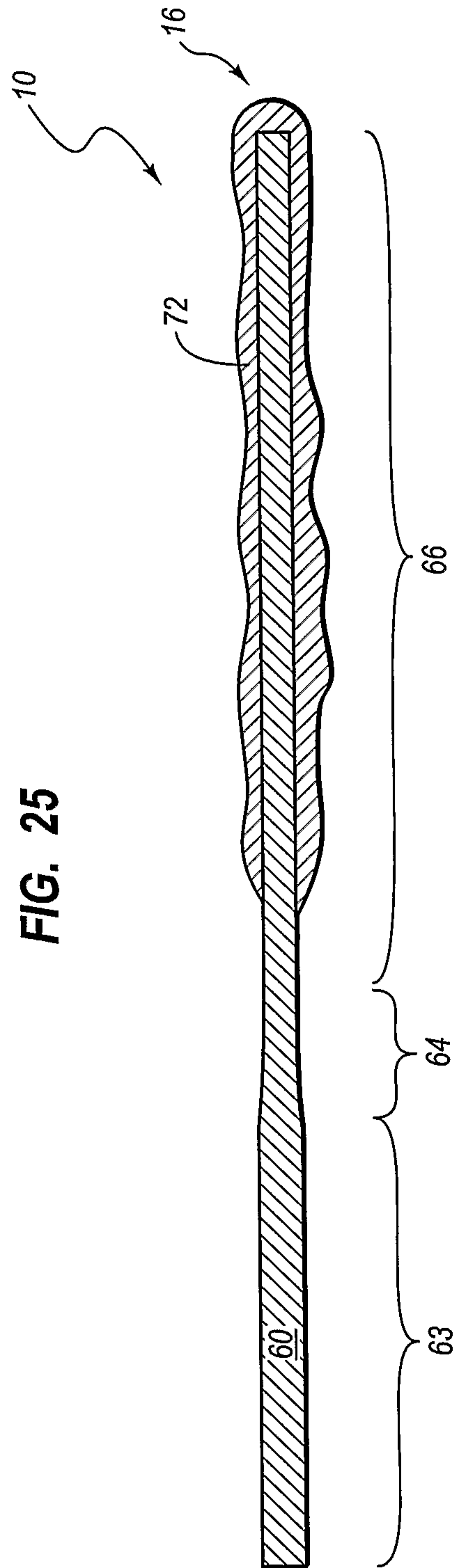

FIG. 26

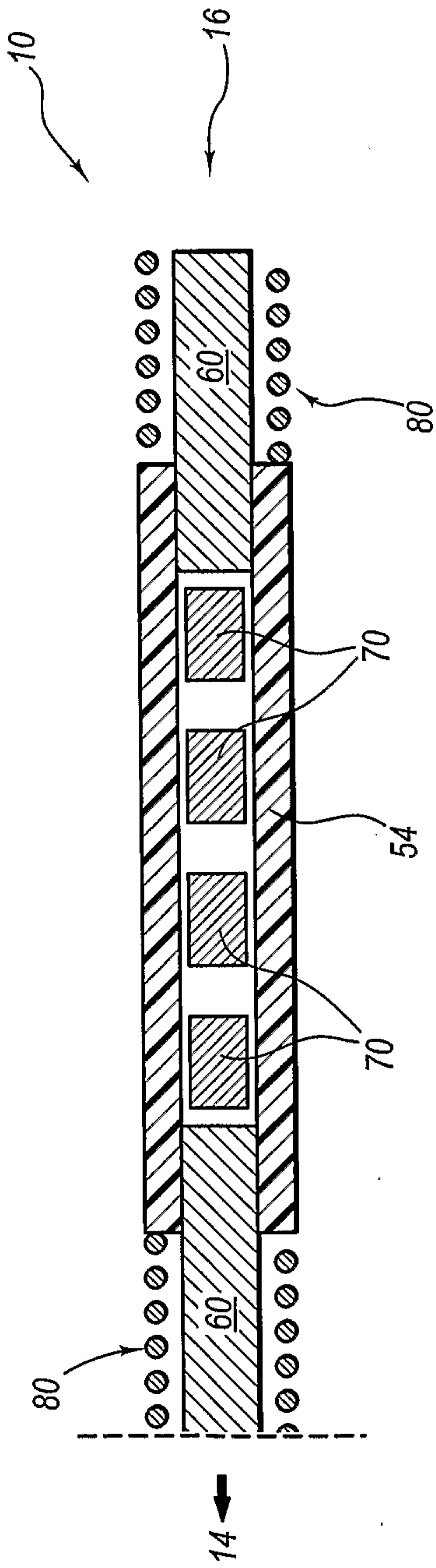

FIG. 27

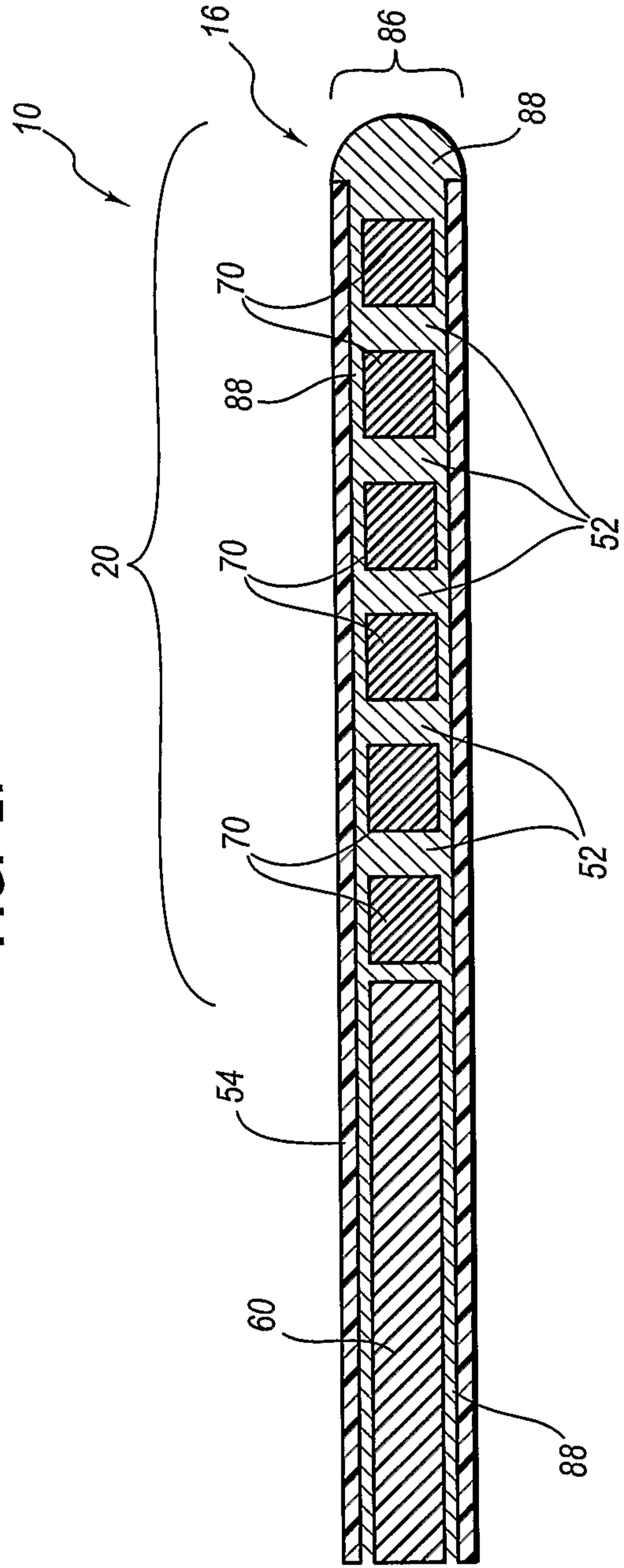

FIG. 28

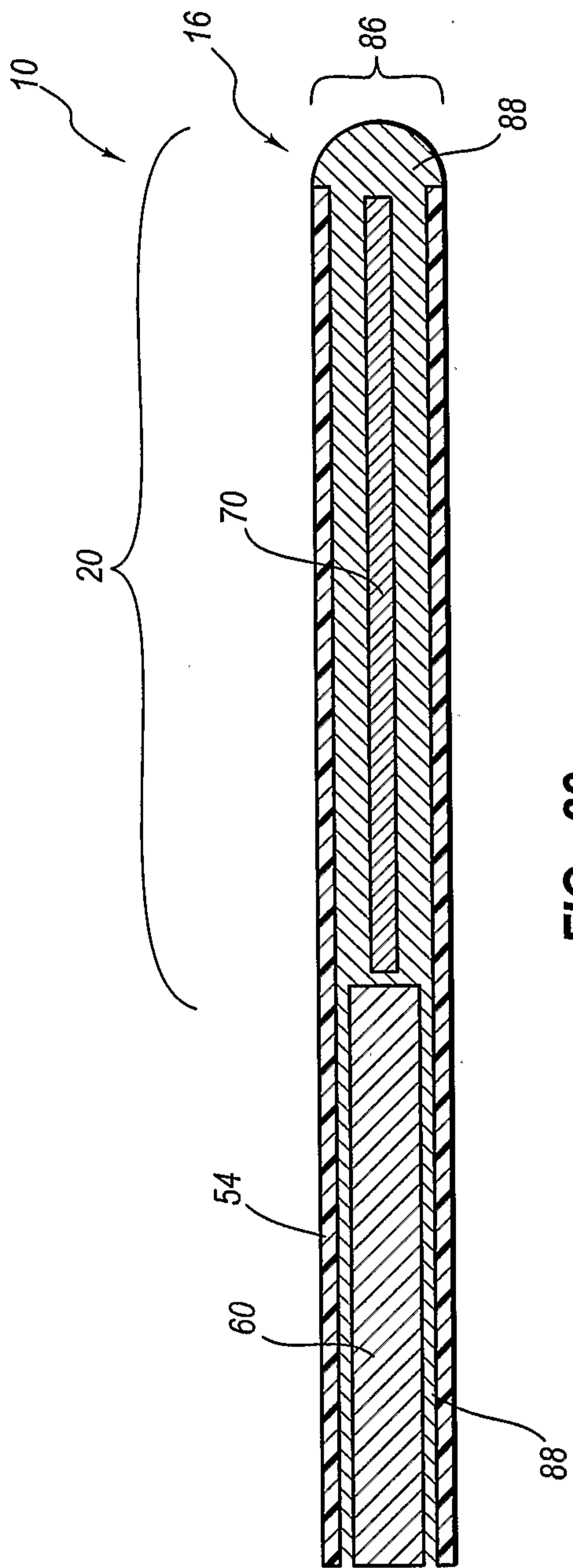

FIG. 29

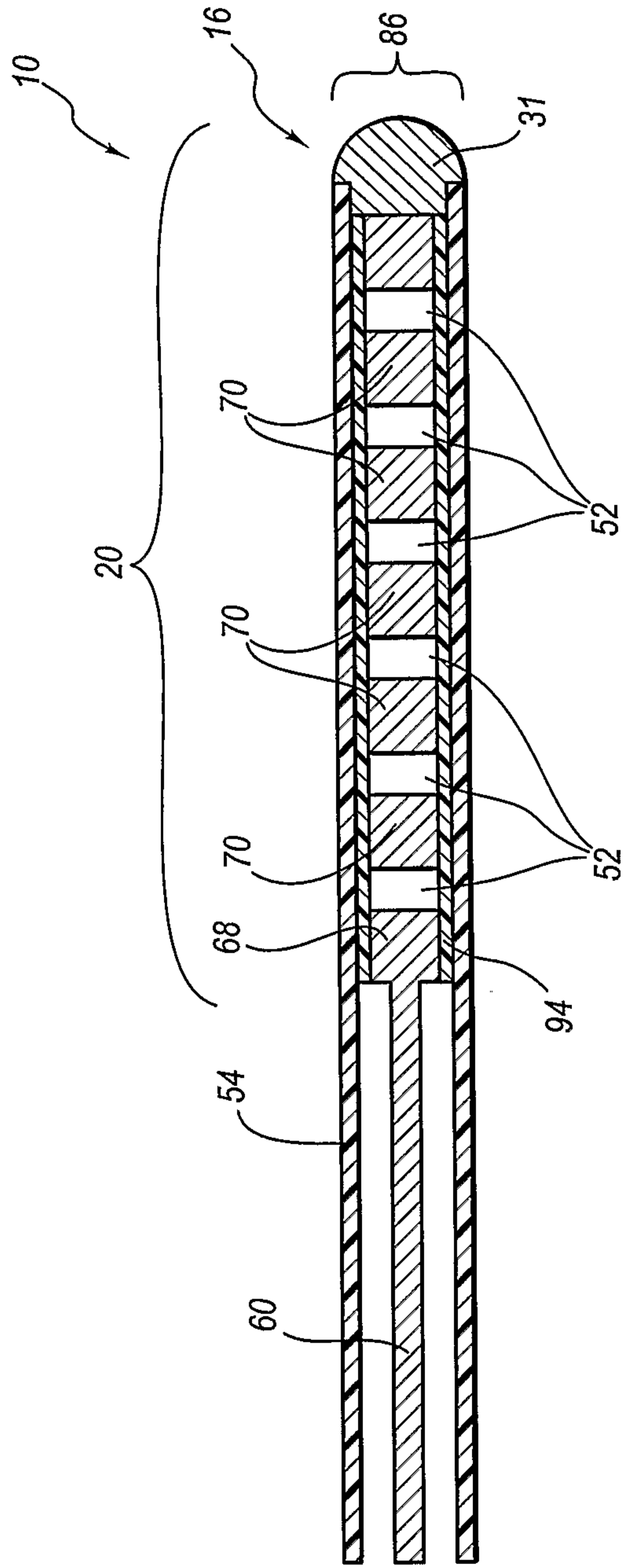

FIG. 30

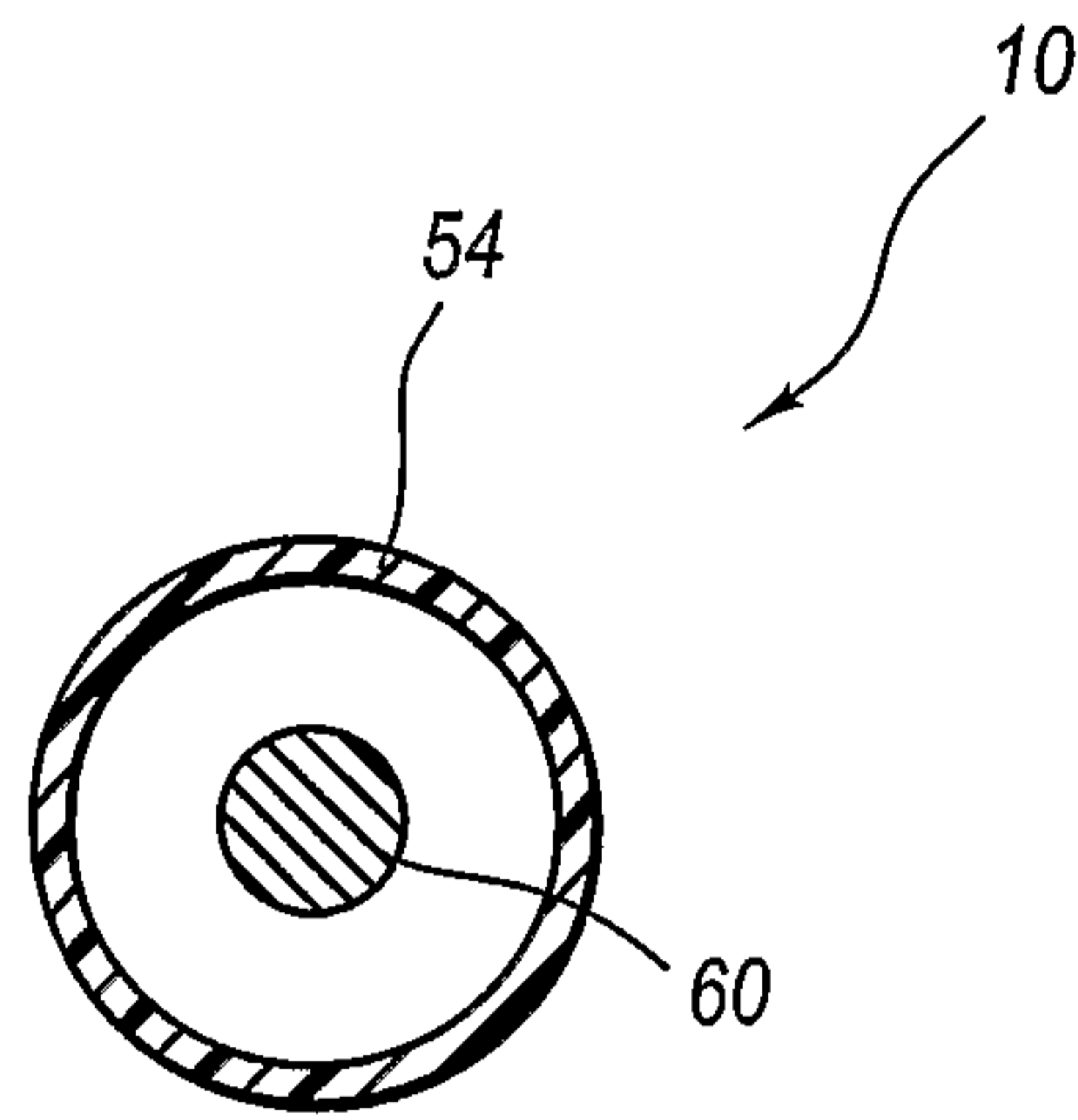

FIG. 31

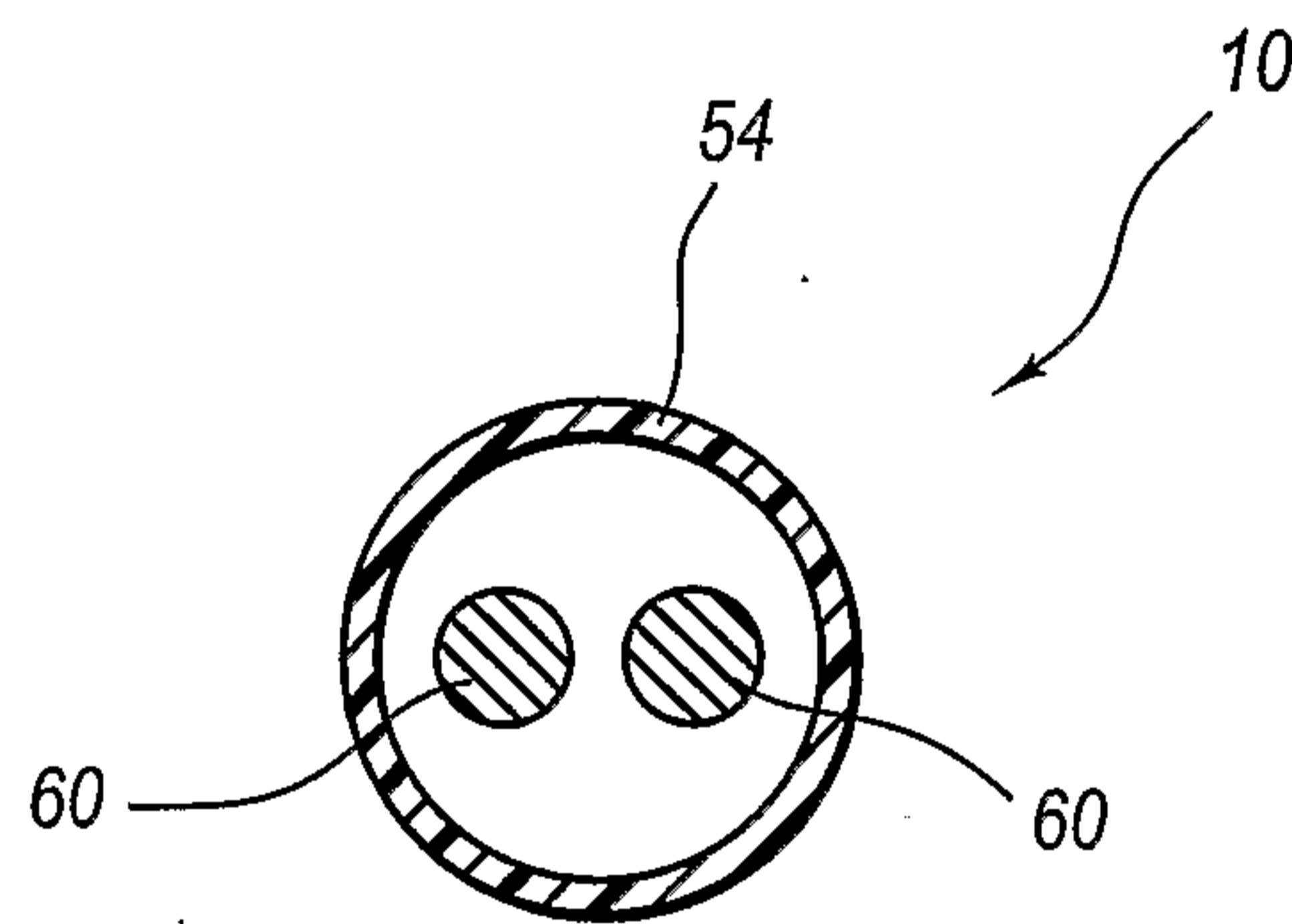

FIG. 32

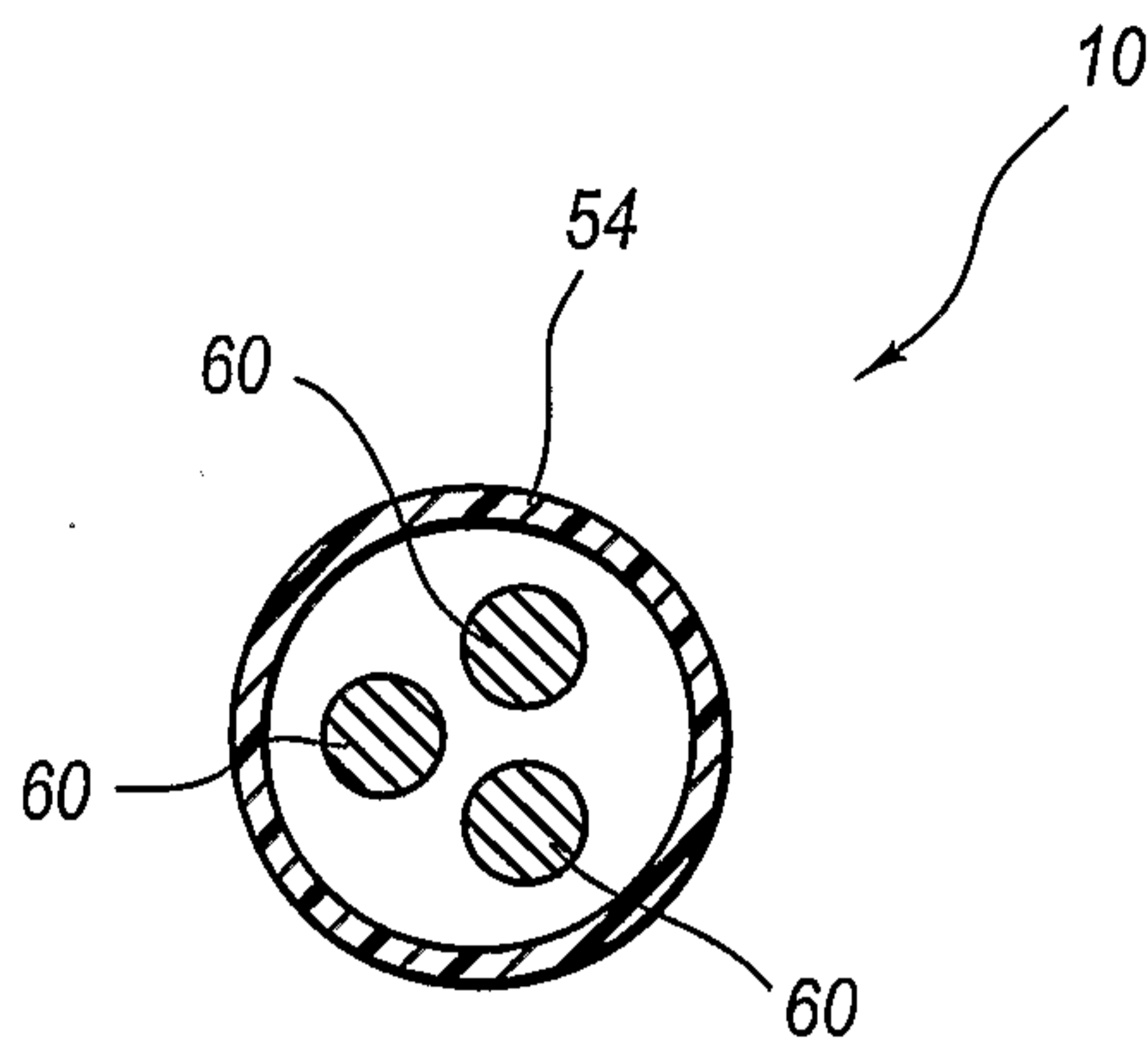

FIG. 33

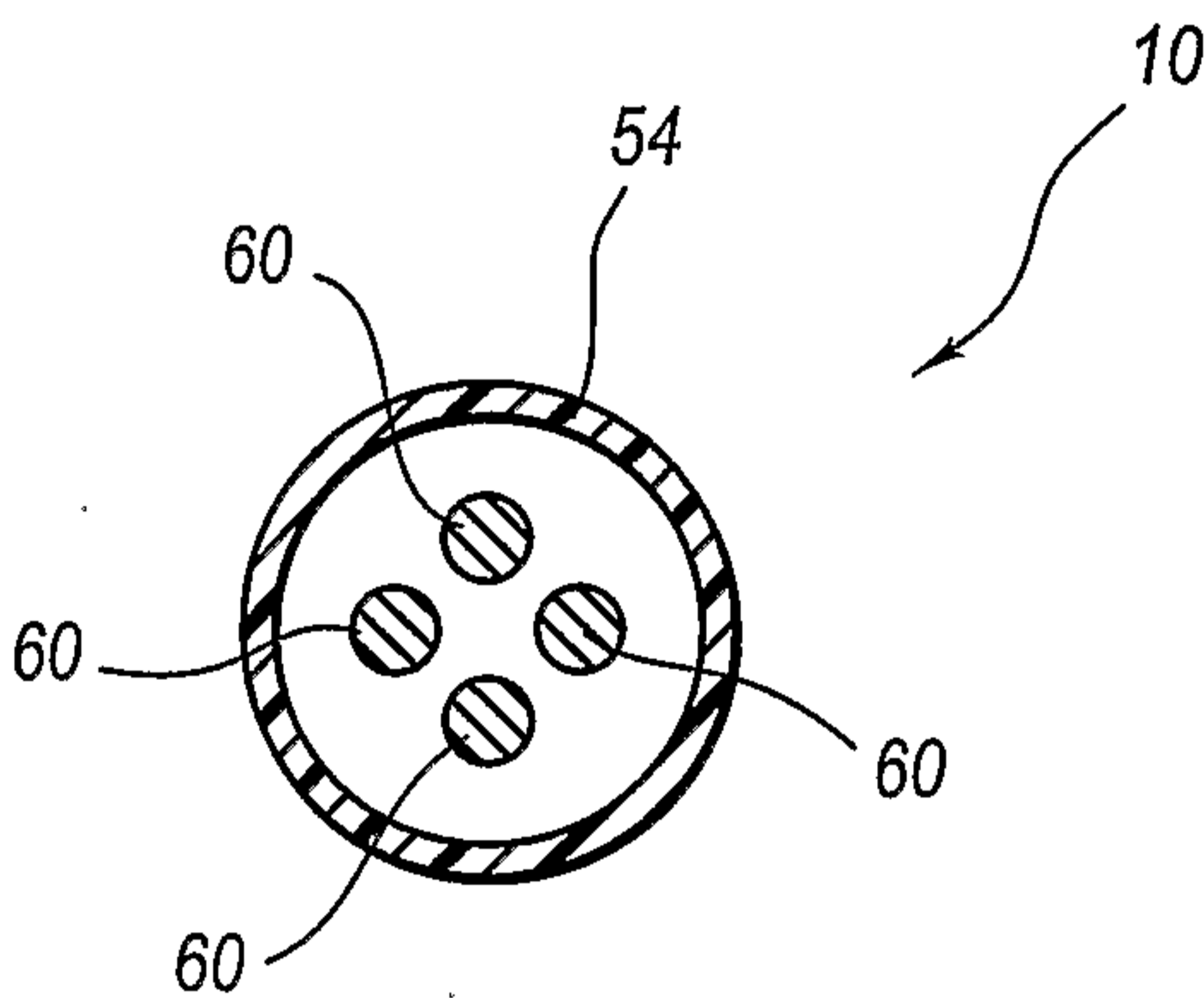

FIG. 34

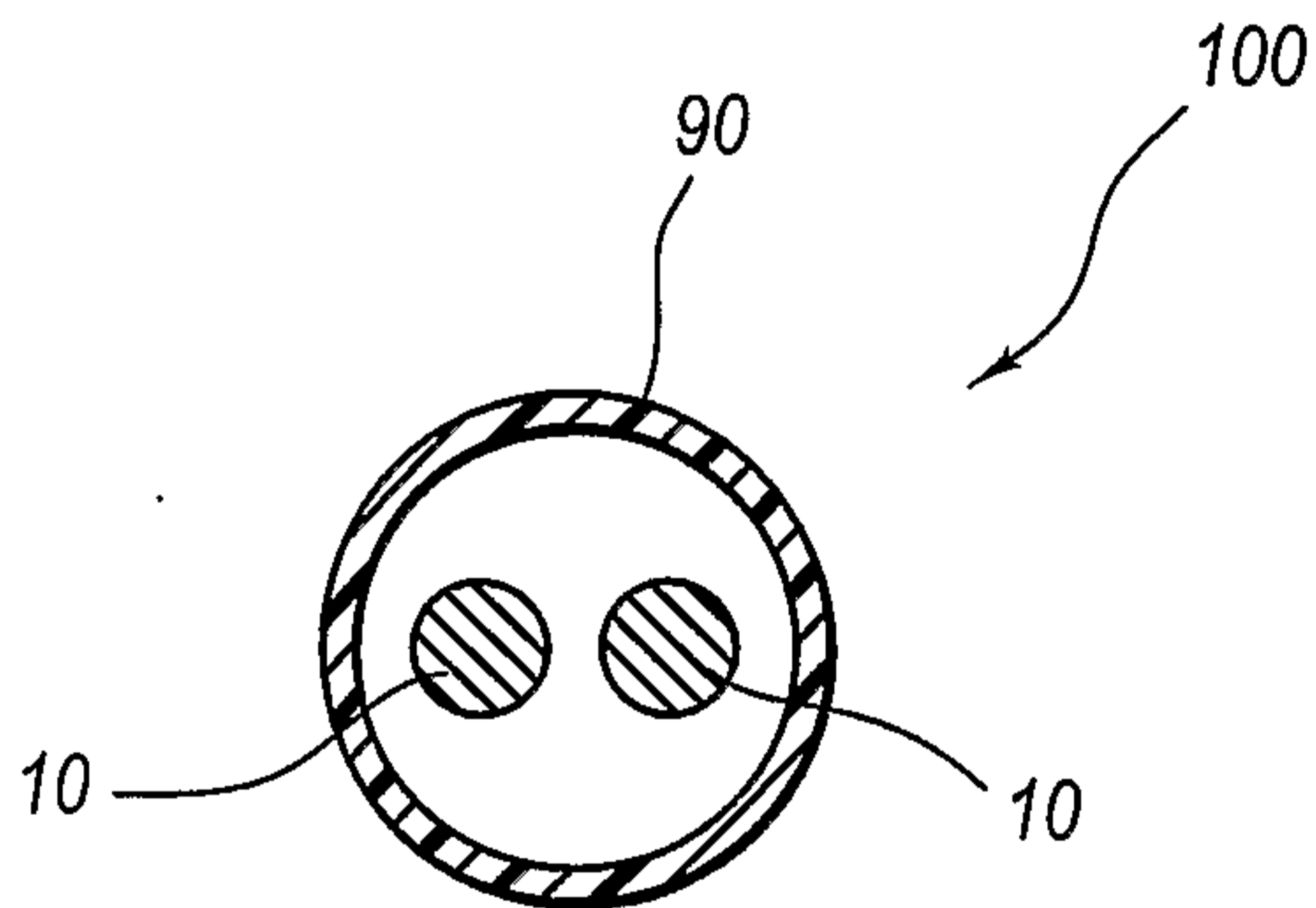

FIG. 35

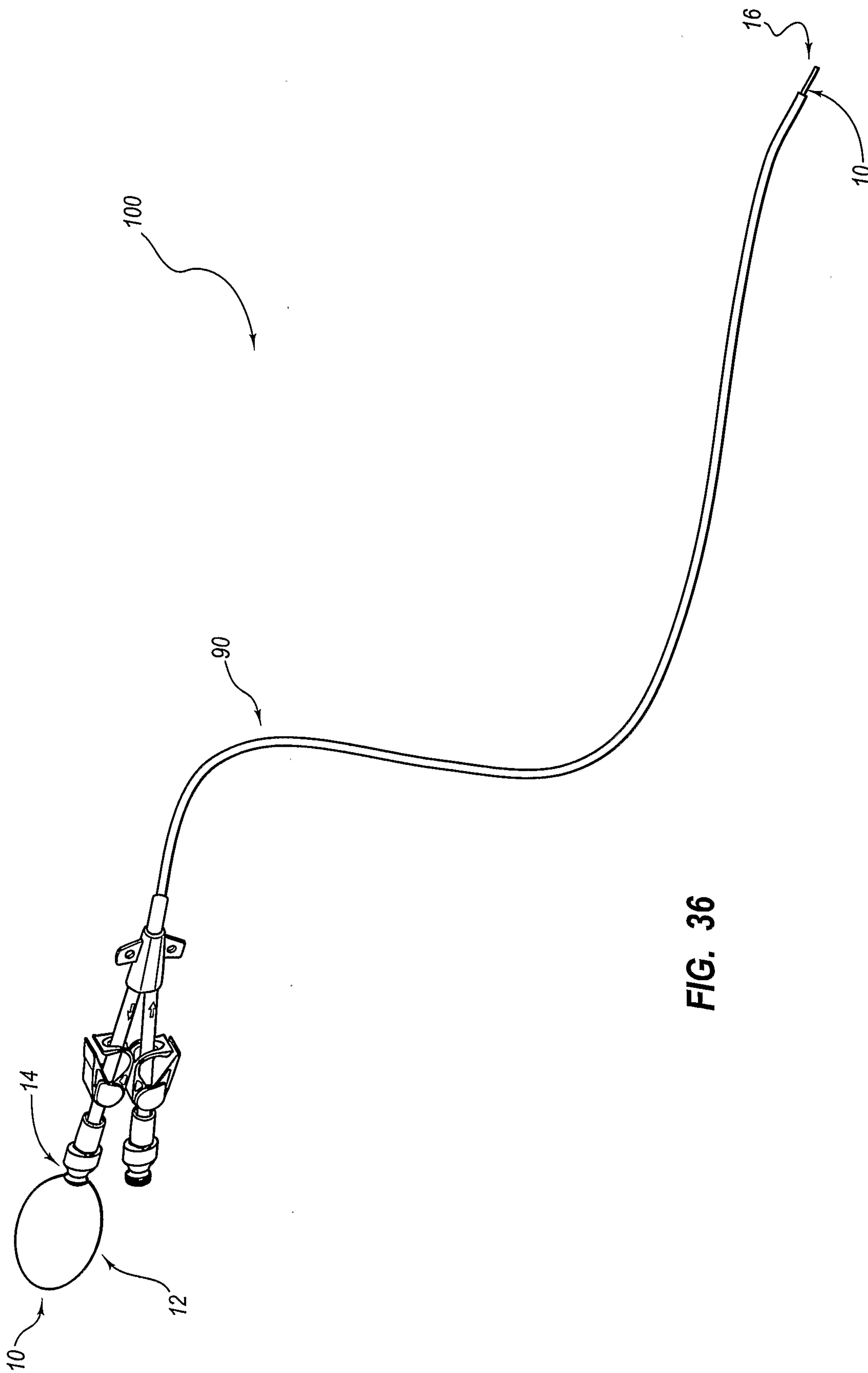

FIG. 36

